

**SECTION AND GROUP  
CONTENTS**

**SECTION 1 GENERAL INFORMATION**

Group 1 Precautions for disassembling and Assembling
Group 2 Tightening Torque
Group 3 Painting
Group 4 Bleeding Air from Hydraulic Oil Tank

**WORKSHOP MANUAL**

---

**SECTION 2 UPPERSTRUCTURE**

Group 1 Cab
Group 2 Counterweight
Group 3 Main Frame
Group 4 Pump Device
Group 5 Control Valve
Group 6 Swing Device
Group 7 Pilot Valve
Group 8 Pilot Shut-Off Solenoid Valve
Group 9 Signal Control Valve
Group 10 4-Spool Solenoid Valve Unit
Group 11 Engine

**SECTION 3 UNDERCARRIAGE**

Group 1 Swing Bearing
Group 2 Travel Device
Group 3 Center Joint
Group 4 Track Adjuster
Group 5 Front Idler
Group 6 Upper and Lower Roller
Group 7 Track

**SECTION 4 FRONT ATTACHMENT**

Group 1 Front Attachment
Group 2 Cylinder
Group 3 Holding Valve

## GENERAL / Tightening

### TORQUE CHART







**⚠ CAUTION:** Use tools appropriate for the work to be done. Makeshift tools and procedures can create safety hazards. For loosening and tightening nuts and bolts, use correct size tools. Otherwise, tightening tools may slip, potentially causing personal injury.



#### Bolt Types

Tighten nuts or bolts correctly to torque specifications. Four different types and grades of bolt are employed. Make sure to employ correct bolts and tighten them correctly when assembling the machine or components.

SA-040

Bolt Dia.	Wrench Size	Hexagon Wrench Size	   <small>M552-07-091</small>			   <small>M552-07-090</small>			 <small>M552-07-092</small>		
			Socket Bolt								
			N-m	(kgf.m)	(lbf.ft)	N-m	(kgf.m)	(lbf.ft)	N-m	(kgf.m)	(lbf.ft)
M6	10	5							3.3 to 4.2	(0.3 to 0.4)	(2.4 to 3.0)
M8	13	6	30	(3.0)	(21.5)	20	(2.0)	(14.5)	10	(1.0)	(7.2)
M10	17	8	65	(6.5)	(47)	50	(5.0)	(36)	20	(2.0)	(14.5)
M12	19	10	110	(11)	(80)	90	(9.0)	(65)	35	(3.5)	(25.5)
M14	22	12	180	(18)	(130)	140	(14)	(101)	55	(5.5)	(40)
M16	24	14	270	(27)	(195)	210	(21)	(152)	80	(8.0)	(58)
M18	27	14	400	(40)	(290)	300	(30)	(215)	120	(12)	(87)
M20	30	17	550	(55)	(400)	400	(40)	(290)	170	(17)	(123)
M22	32		750	(75)	(540)	550	(55)	(400)	220	(22)	(159)
M24	36		950	(95)	(690)	700	(70)	(510)	280	(28)	(205)
M27	41		1400	(140)	(1010)	1050	(105)	(760)	400	(40)	(290)
M30	46		1950	(195)	(1410)	1450	(145)	(1050)	550	(55)	(400)
M33	50		2600	(260)	(1880)	1950	(195)	(1410)	750	(75)	(540)
M36	55		3200	(320)	(2310)	2450	(245)	(1770)	950	(95)	(690)

## UPPERSTRUCTURE / Cab

9. Install cover (20) to cab (5) with screws (21) (2 used). Install cover (20) to cab (5) with screw (23). Install cap (22) to screw (23).

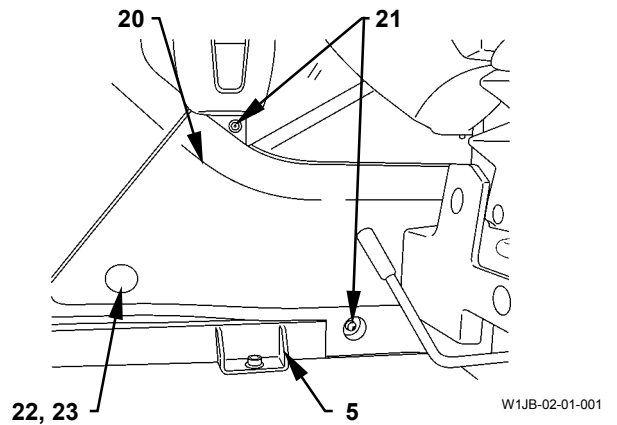

10. Install bracket (16) to bracket (18) with bolts (15) (2 used). Install cover (17) to bracket (18) with bolts (19) (2 used).

 : 13 mm

 : 20 N·m (2 kgf·m, 15 lbf·ft)

 : 17 mm

 : 50 N·m (5 kgf·m, 37 lbf·ft)

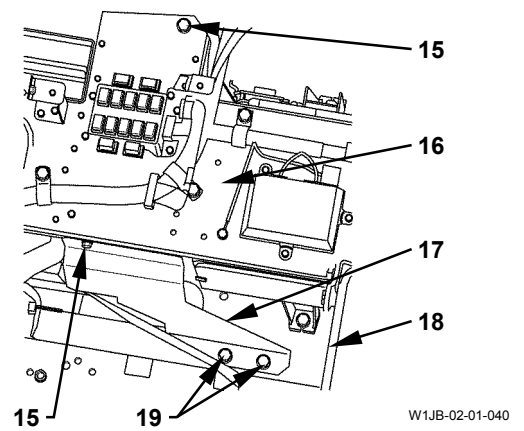

11. Install cover (11) to cab (5) with bolts (14) (5 used). Install caps (13) (6 used) to screws (14) (6 used).

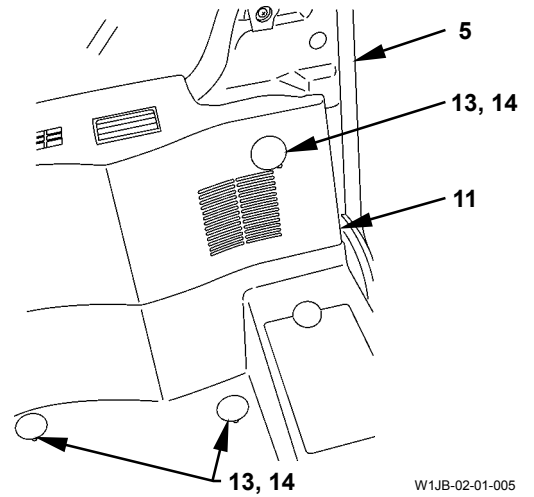

12. Install cover (11) to cab (5) with bolts (12) (2 used).

 : 13 mm

 : 20 N·m (2 kgf·m, 15 lbf·ft)

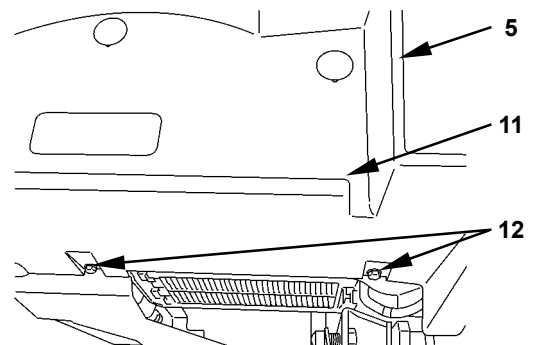

# UPPERSTRUCTURE / Cab

 NOTE: Unit: mm (1 mm=0.039 in)

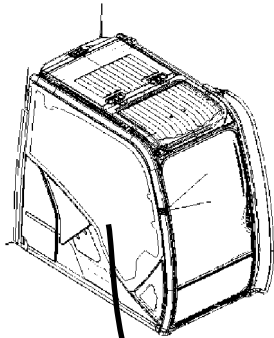

W1JB-02-01-009

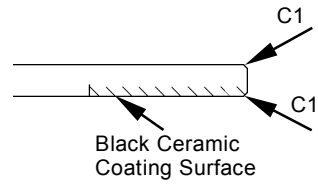

W1JB-02-01-013

Section A

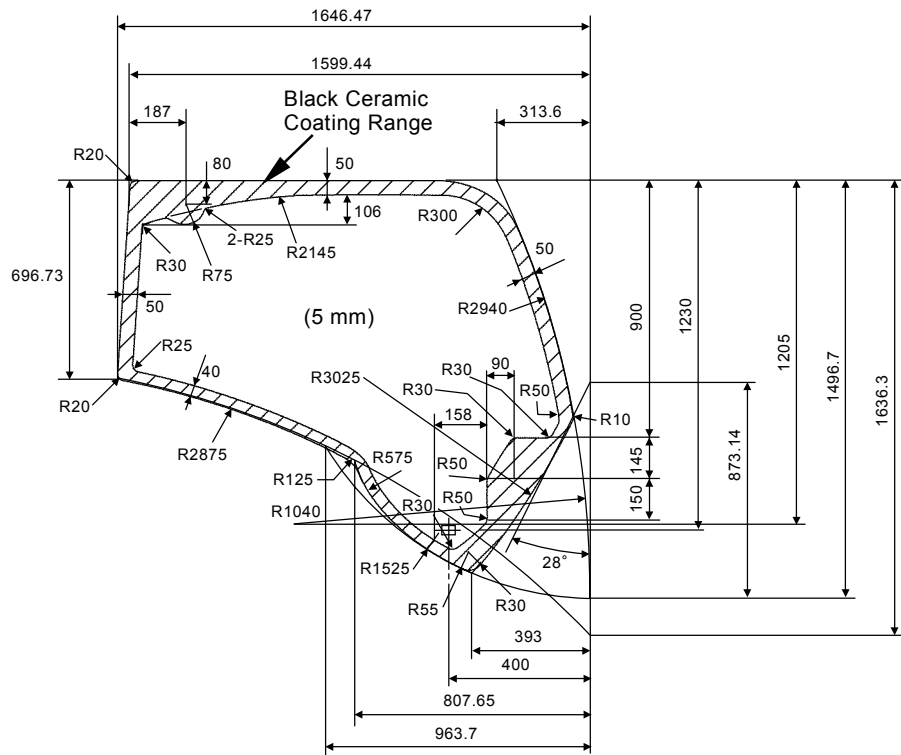

W1JB-02-01-020

## UPPERSTRUCTURE / Pump Device

### REMOVE AND INSTALL PUMP DEVICE (ZX200-3 CLASS, 240-3 CLASS, 270-3 CLASS)

**IMPORTANT:** Release any pressure in the hydraulic oil tank before doing any work. (Refer to BLEED AIR FROM HYDRAULIC OIL TANK on W1-4-1.)

#### Removal

1. Open the engine cover. Remove bolts (1) (9 used) from cover(2). Remove cover (2).

 : 17 mm

2. Remove bolts (5) (4 used) from muffler bracket (3) assembly in the pump space. Remove cover (4). Remove clamp (6). Make the muffler (8) tube free.

 : 17 mm

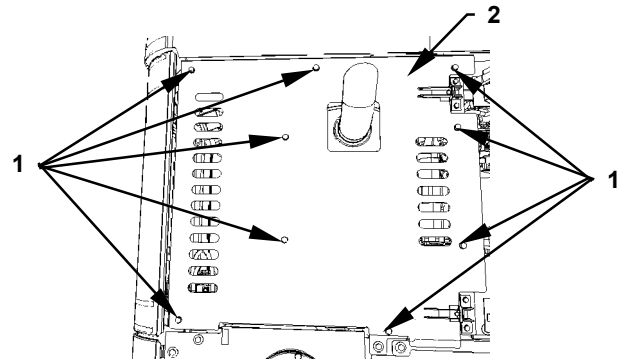

W1V1-02-04-005

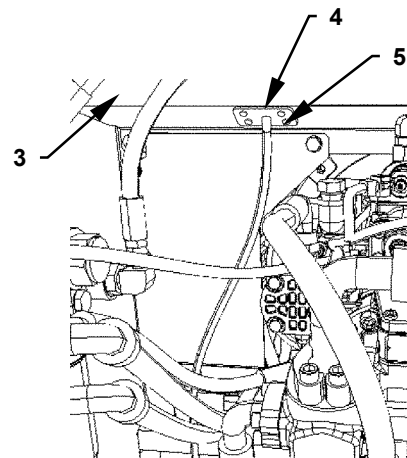

W1V1-02-04-008

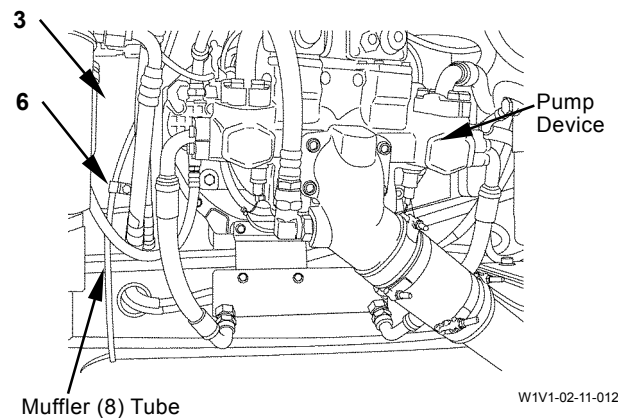

Muffler (8) Tube

W1V1-02-11-012

3. Remove nuts (9) (8 used) and U-bolts (7) (2 used) from bracket (10). Remove the clamp. Remove muffler (8).

 : 14 mm, 17 mm

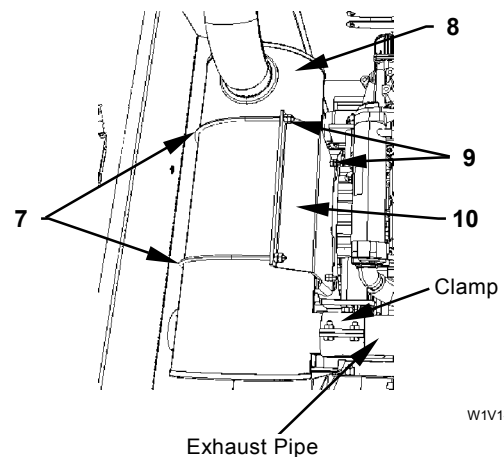













Exhaust Pipe

W1V1-02-04-006

## UPPERSTRUCTURE / Pump Device

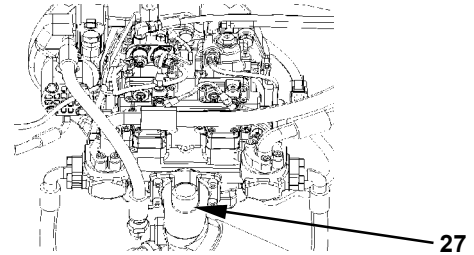

6. Install all hoses, pipes and connectors to pump device (27).

-  : 19 mm
-  : 30 N·m (3.0 kgf·m, 22 lbf·ft)
-  : 22 mm
-  : 40 N·m (4.0 kgf·m, 30 lbf·ft)
-  : 27 mm
-  : 80 N·m (8.0 kgf·m, 59 lbf·ft)
-  : 36 mm
-  : 180 N·m (18 kgf·m, 133 lbf·ft)
-  : 8 mm
-  : 50 N·m (5.0 kgf·m, 37 lbf·ft)
-  : 10 mm
-  : 90 N·m (9.0 kgf·m, 67 lbf·ft)



W1V1-02-04-029

7. Install bracket (17) with bolts (16,18).

-  : 17 mm
-  : 50 N·m (5 kgf·m, 37 lbf·ft)

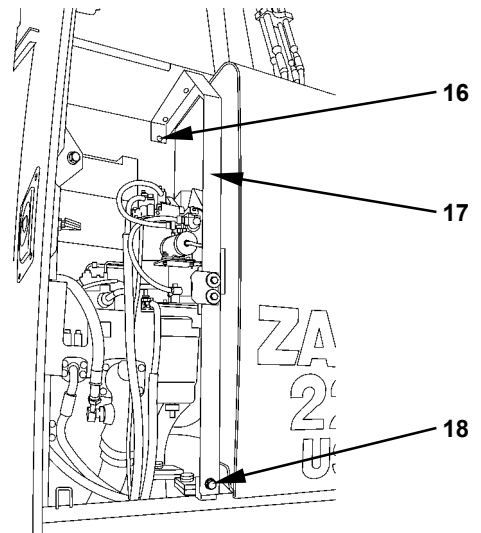

W1V1-02-04-024

# UPPERSTRUCTURE / Pump Device

## DISASSEMBLE REGULATOR

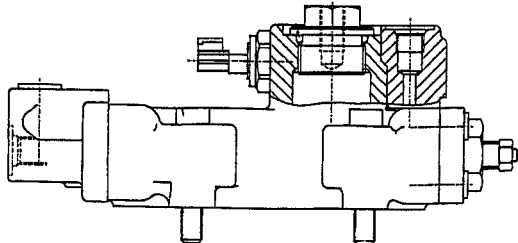

Regulator for Right Pump

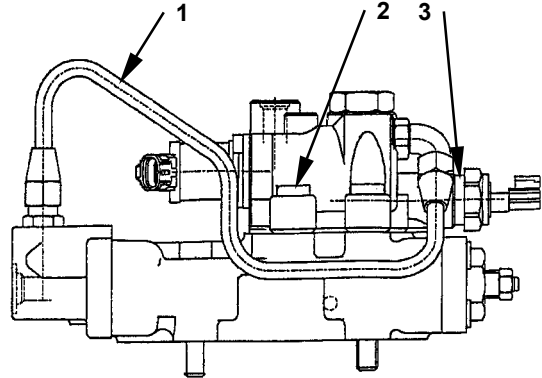

Regulator for Left Pump

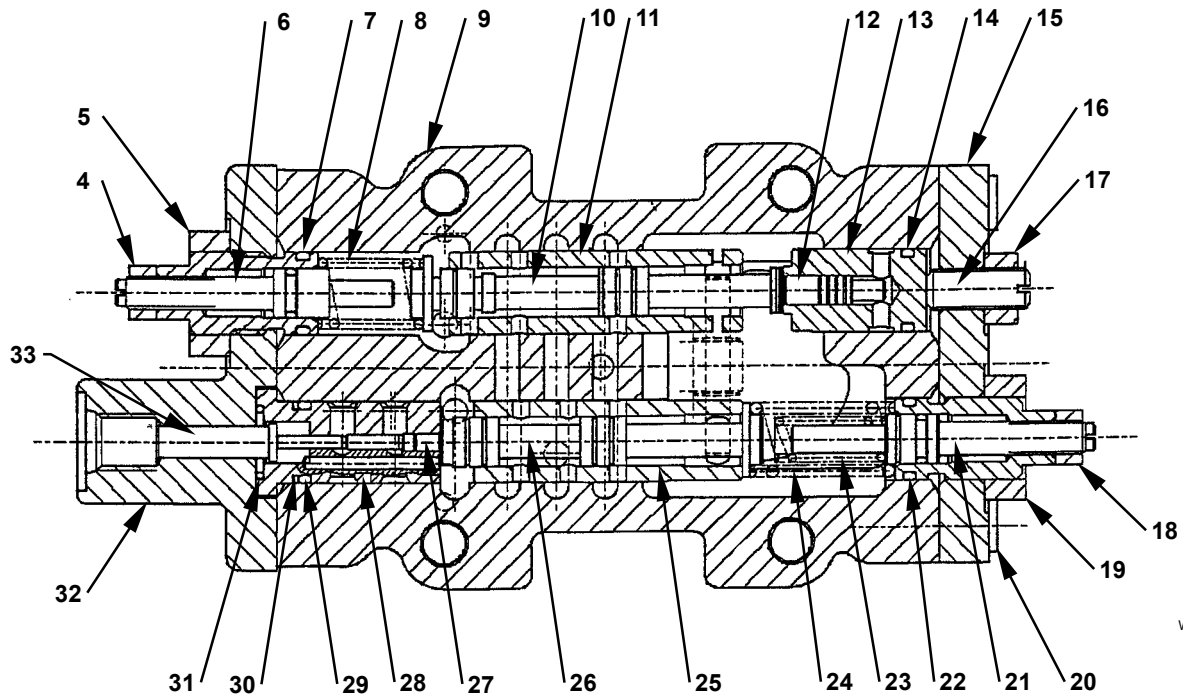

W1V1-02-04-001

- |                          |               |                           |                  |
|--------------------------|---------------|---------------------------|------------------|
| 1 - Pipe                 | 10 - Spool    | 19 - Lock Nut             | 28 - Cylinder    |
| 2 - Socket Bolt (2 Used) | 11 - Sleeve   | 20 - Socket Bolt (8 Used) | 29 - O-Ring      |
| 3 - Solenoid Valve       | 12 - Piston   | 21 - Stopper Assembly     | 30 - Backup Ring |
| 4 - Lock Nut             | 13 - Cylinder | 22 - O-Ring               | 31 - O-Ring      |
| 5 - Lock Nut             | 14 - O-Ring   | 23 - Spring               | 32 - Cover       |
| 6 - Stopper Assembly     | 15 - Cover    | 24 - Spring               | 33 - Piston      |
| 7 - O-Ring               | 16 - Set Bolt | 25 - Sleeve               |                  |
| 8 - Spring               | 17 - Lock Nut | 26 - Spool                |                  |
| 9 - Casing               | 18 - Lock Nut | 27 - Piston               |                  |

# UPPERSTRUCTURE / Control Valve

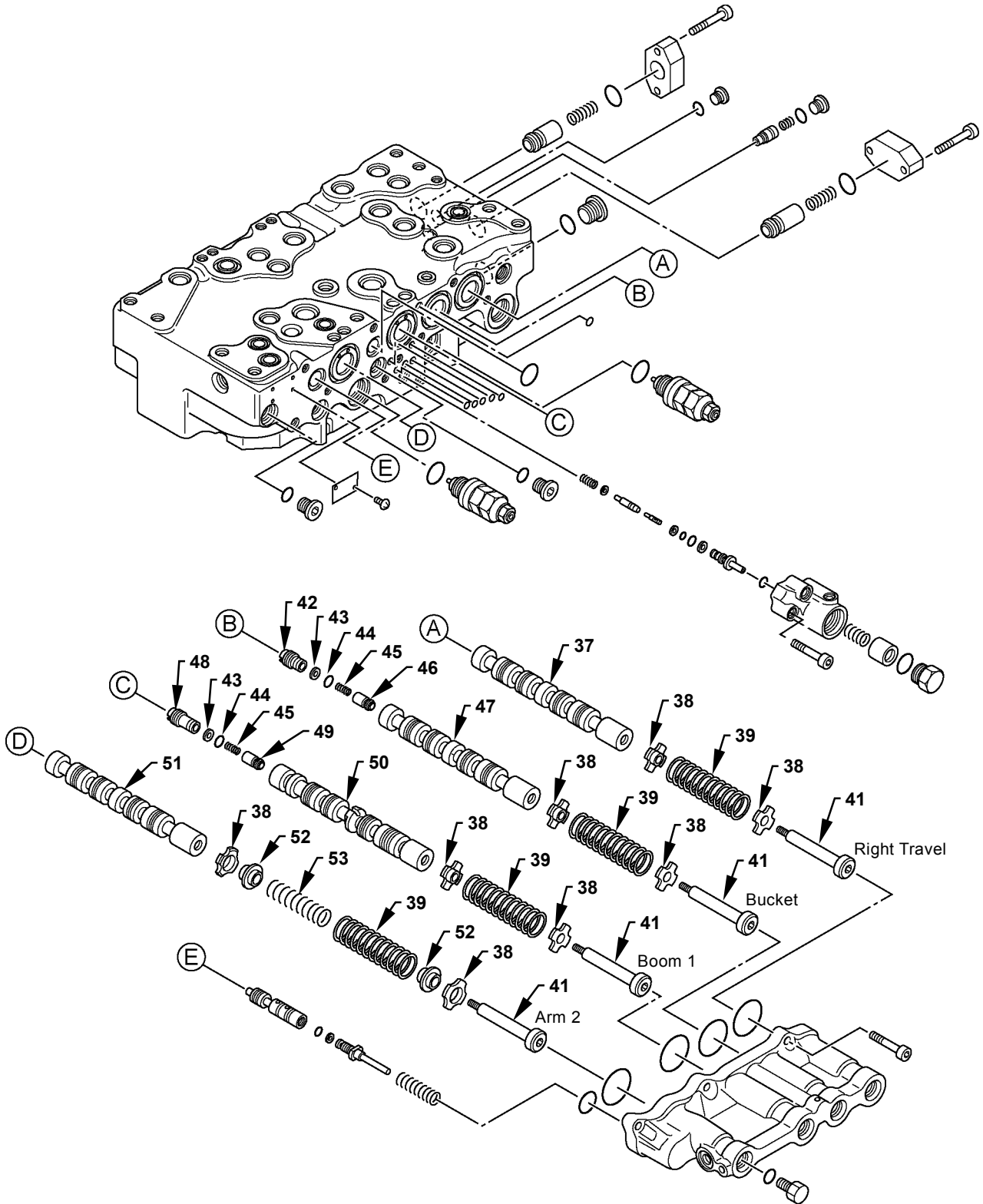

W1V1-02-05-024



# UPPERSTRUCTURE / Control Valve

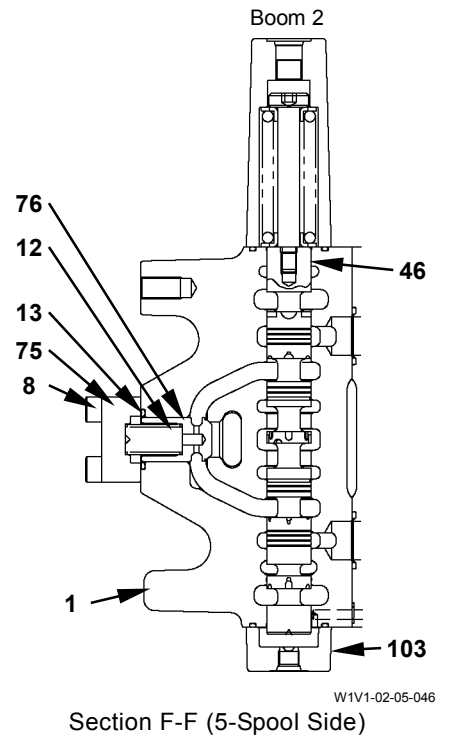
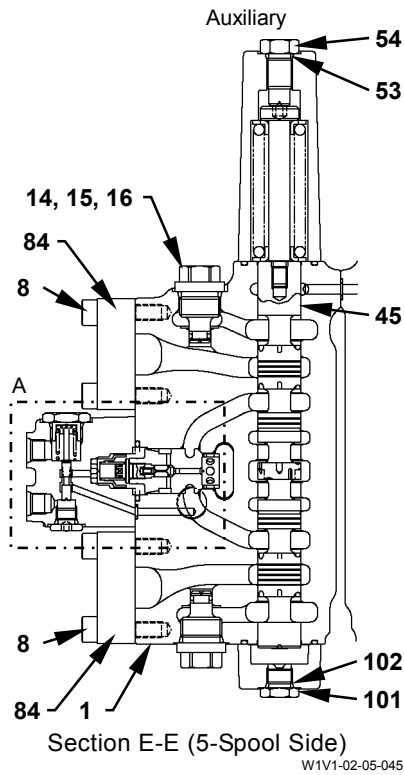
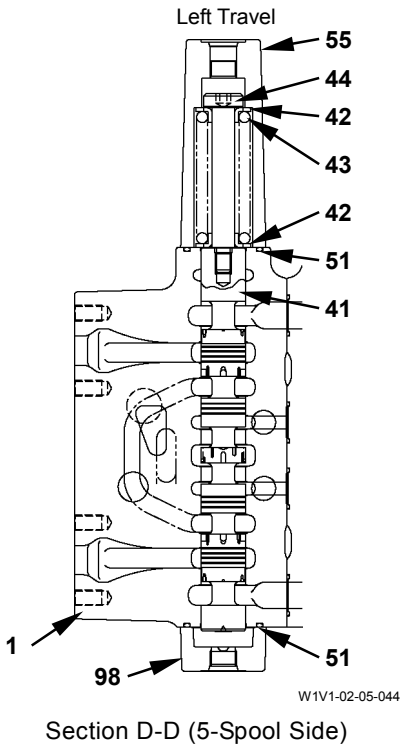
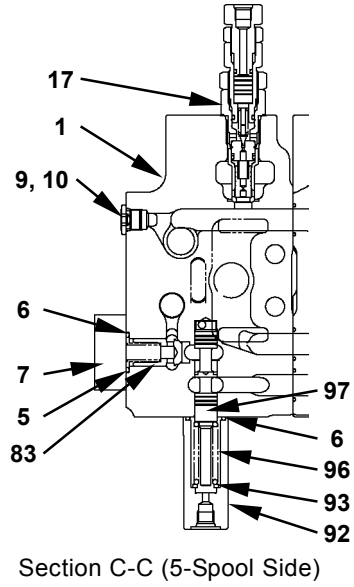
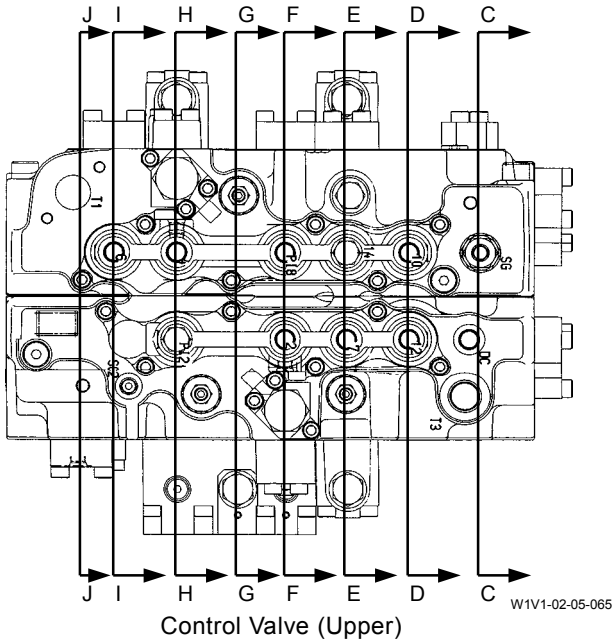

## UPPERSTRUCTURE / Swing Device

15. Hoist and place the housing (26) assembly on the bracket. Install the housing (26) assembly with the bolts (ZX200-3 class, 225USR-3 class, 225US-3 class: M20, Pitch 2.5 mm, 240-3 class, ZX270-3 class: M22, Pitch 2.5 mm) (2 used) so that the stopper located at the bottom of bracket is inserted into the middle of two teeth of pinion gear in shaft (31). Secure the bracket on a work bench in order to reduce the reaction force.

 : 30 mm

Bracket:

ZX200-3 class, 225USR-3 class, 225US-3 class:  
ST5097

ZX240-3 class, 270-3 class: ST 5100

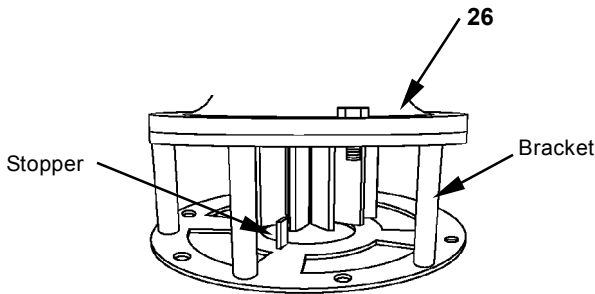

W178-02-11-134

**IMPORTANT: Check the direction to install bearing nut (15).**

16. Apply a film of grease on the thread part of bearing nut (15). Install bearing nut (15) to shaft (31) with the step part of bearing nut (15) facing to roller bearing (14). Tighten by using special tool (ST 2926) to the specified torque.

ZX200-3 class, 225USR-3 class, 225US-3 class

 : 490 N·m (50 kgf·m, 360 lbf·ft)

ZX240-3 class, 270-3 class

 : 590 N·m (60 kgf·m, 435 lbf·ft)

 **NOTE:** Apply grease for keeping correct tightening torque.

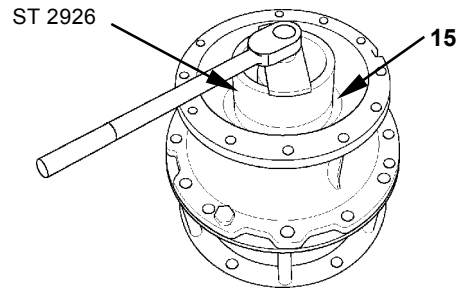

W178-02-11-146

17. Install lock plate (16) to bearing nut (15) with bolts (17) (2 used). In case the splines of lock plate (16) and shaft (31) are not aligned, tighten bearing nut (15) in tightening direction until both splines are aligned.

 : 17 mm

 : 50 N·m (5.0 kgf·m, 37 lbf·ft)

18. Secure planetary gear (12) and needle bearings (11) (2 used) with thrust plate (13). Install the planetary gear (12) assembly to second stage carrier (18).

## UPPERSTRUCTURE / Signal Control Valve

### REMOVE AND INSTALL SIGNAL CONTROL VALVE (ZX225USR-3Class, 225US-3 Class)

#### Removal

1. Open and lock front cover (1).
2. Remove bolt (3). Open side cover (2).

 : 17 mm

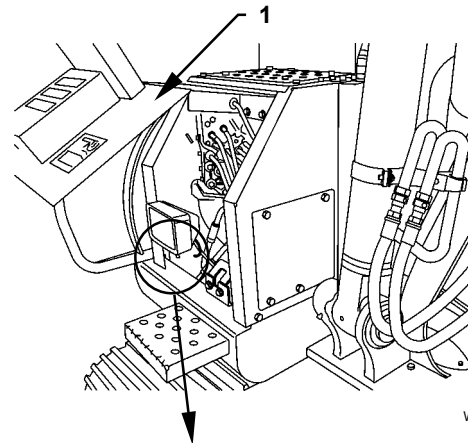

W1V1-02-05-075

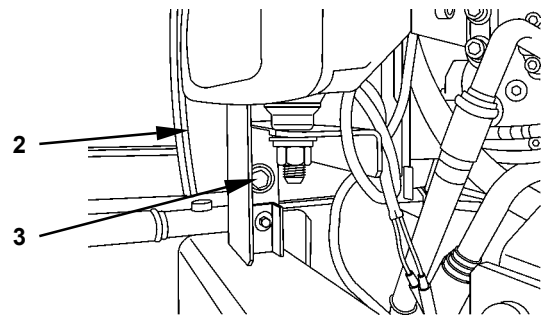

W1V1-02-05-076

3. Remove bolts (5, 7) (2 used for each). Remove brackets (6) (2 used) from upper cover (9).

 : 17 mm

4. Remove bolts (4) (5 used). Remove upper cover (9).

 : 17 mm

5. Remove bolts (8A, 8B, 12A, 12B). Remove brackets (10, 11).

 : 17 mm

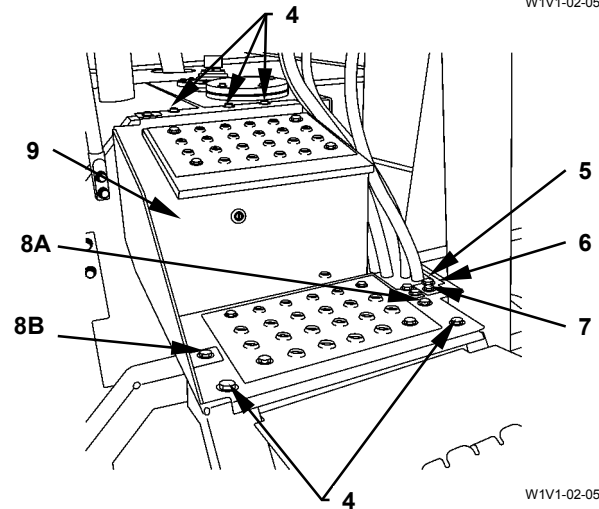

W1V1-02-05-078

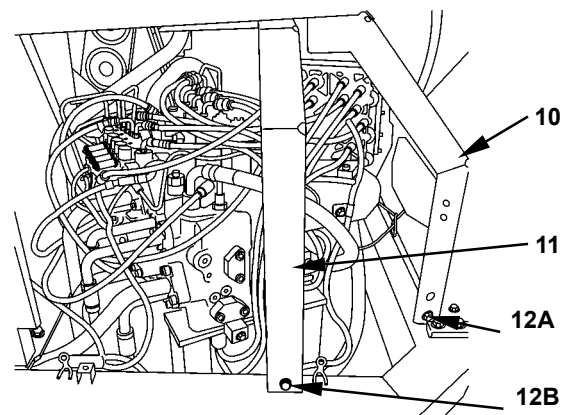

W1V1-02-05-079

## UPPERSTRUCTURE / Engine

4. Install engine brackets (92) (2 used) at pump side to the main frame with washers (94) (2 used) and nuts (93) (2 used).

 : 27 mm

 : 400 N·m (41 kgf·m, 295 lbf·ft)

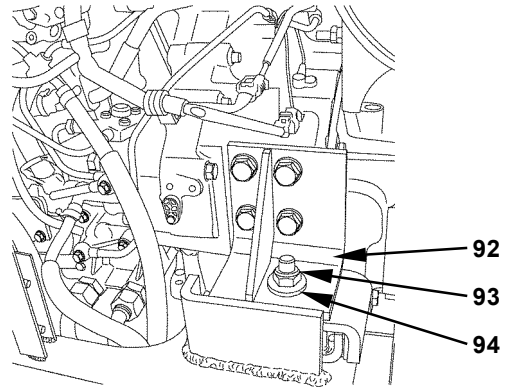

W1V1-02-11-022

5. Cover shroud (89) with rubber (91). Secure rubber (89) with band (90).

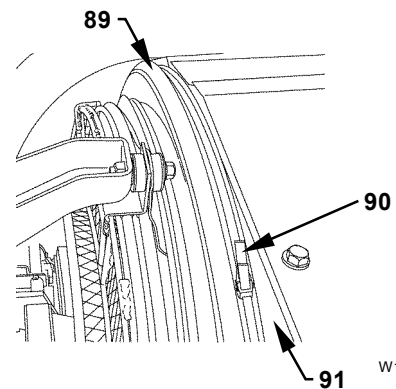

W1V1-02-11-010

6. Install wirings (82, 84) to the starter (86) terminal through the cover mounting side under engine with nuts (83, 85). Install ground line (87) to main frame (2) with bolt (88).

 : 17 mm

 : 50 N·m (5 kgf·m, 37 lbf·ft)

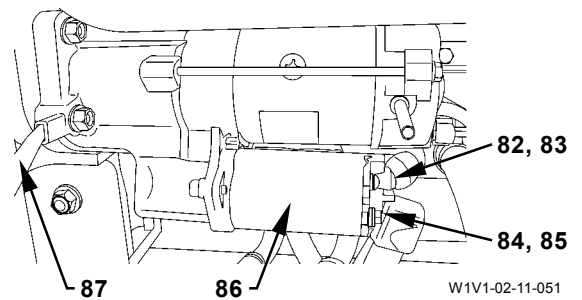

W1V1-02-11-051

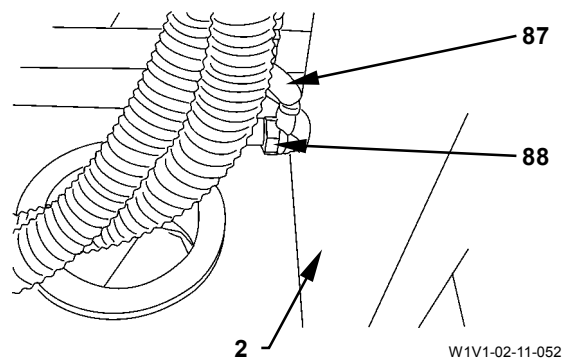

W1V1-02-11-052

# UNDERCARRIAGE / Travel Device

## DISASSEMBLE BRAKE VALVE

ZX200-3 class, 225USR-3 class, 225US-3 class,  
240-3 class

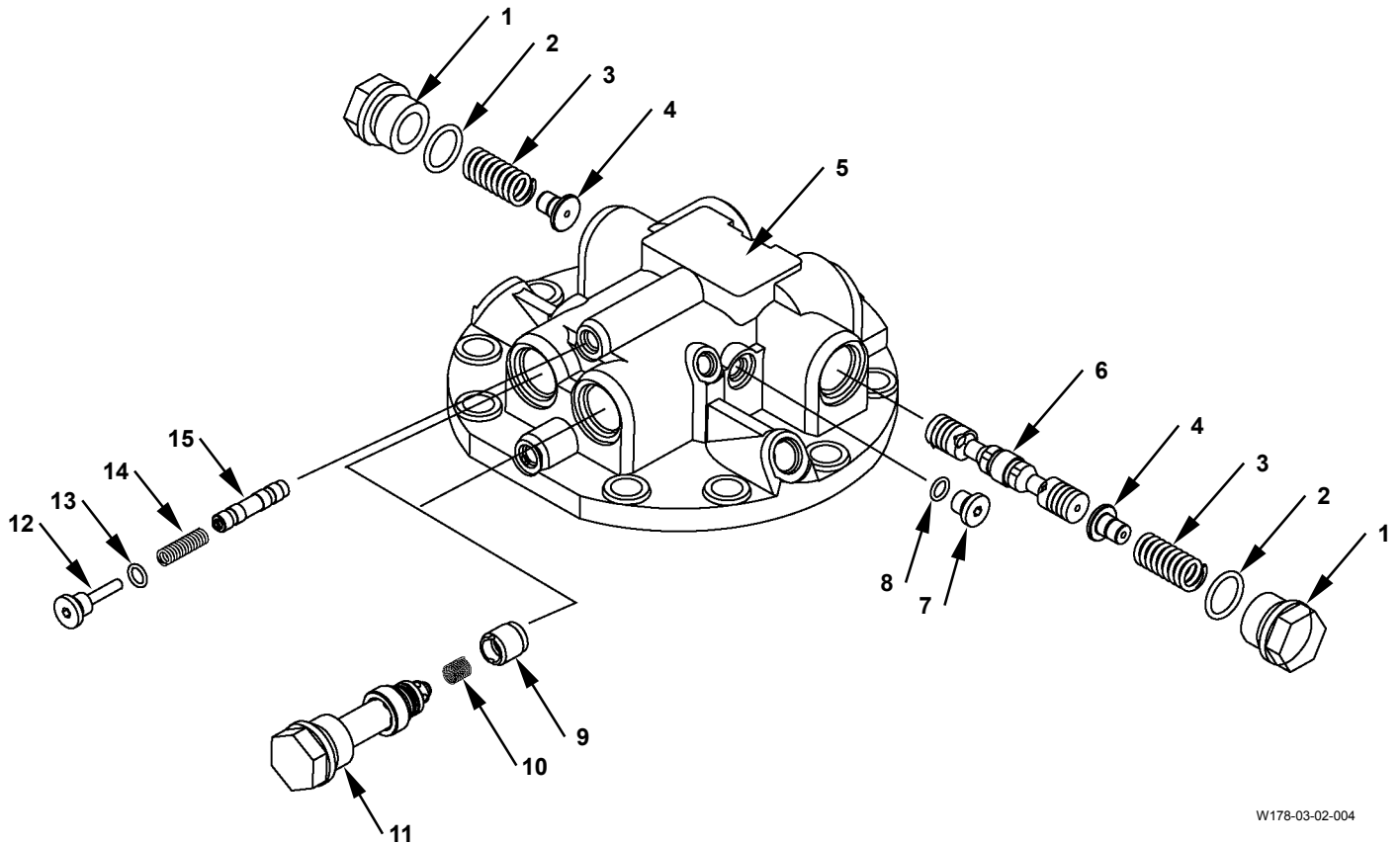

W178-03-02-004

- |                      |                   |                            |             |
|----------------------|-------------------|----------------------------|-------------|
| 1 - Plug (2 Used)    | 5 - Valve Housing | 9 - Poppet (2 Used)        | 13 - O-Ring |
| 2 - O-Ring (2 Used)  | 6 - Spool         | 10 - Spring (2 Used)       | 14 - Spring |
| 3 - Spring (2 Used)  | 7 - Plug          | 11 - Relief Valve (2 Used) | 15 - Spool  |
| 4 - Stopper (2 Used) | 8 - O-Ring        | 12 - Plug                  |             |

# UNDERCARRIAGE / Front Idler

---

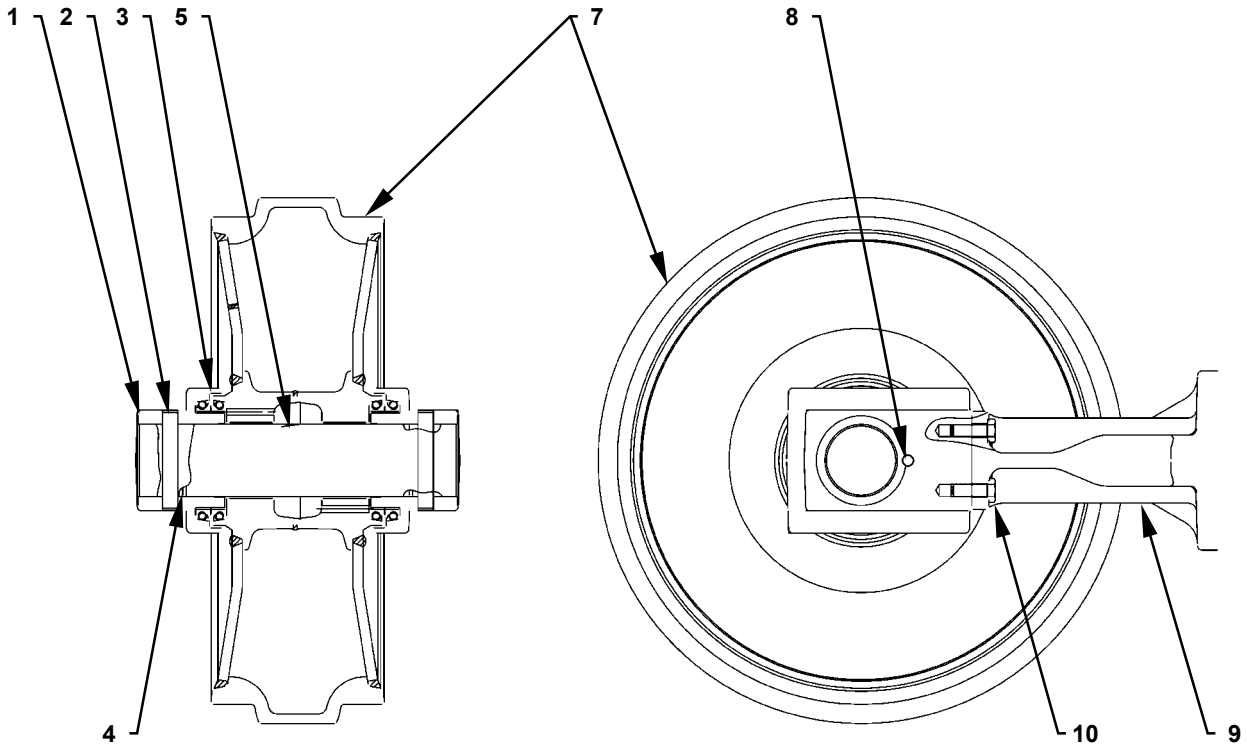

W1V7-03-05-002

## FRONT ATTACHMENT / Front Attachment



**CAUTION:** Metal fragments may fly off when a hammer is used. Wear necessary protection, such as goggles, hard hats, etc in order to prevent personal injury.

10. Hoist and hold the boom cylinder. Insert thrust plates (2) (2 used). Install pin (3). Install the boom cylinder on both sides.

11. Install stopper (5). Tighten with bolt (6) and nuts (4) (2 used). (2 places on both left and right)

 : 30 mm

 : 550 N·m (55 kgf·m, 405 lbf·ft)

12. Install lubrication pipe (1) to the rod side of boom cylinder. (2 places on both left and right)

 : 17 mm

 : 30 N·m (3.0 kgf·m, 22 lbf·ft)

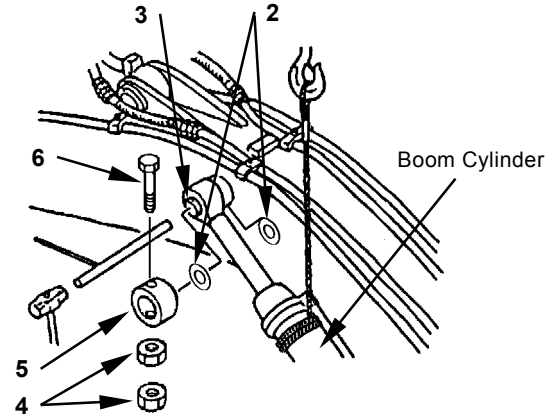

W178-04-01-004

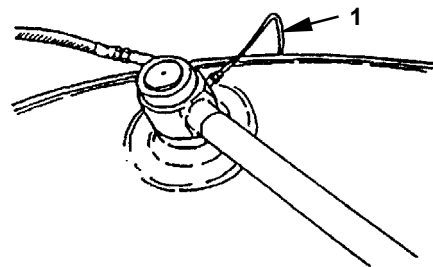

W105-04-01-002

13. Apply grease to the rod side, bottom side and boom foot side of boom cylinder.

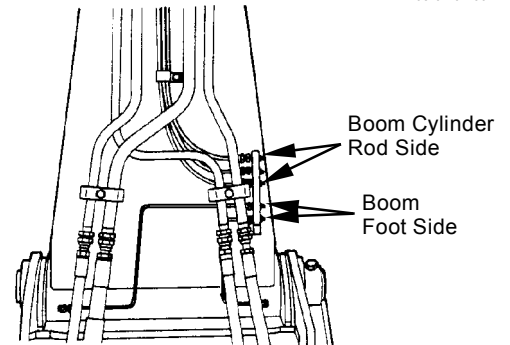

W1V1-04-01-001