

Table of Contents

	Section
Introduction	i
Engine and System Identification	E
Operating Instructions	1
Maintenance Guidelines	2
Maintenance Procedures at Daily Interval	3
Maintenance Procedures at 250 Hours or 6 Months	4
Maintenance Procedures at 500 Hours or 6 Months	5
Maintenance Procedures at 1000 Hours or 1 Year	6
Maintenance Procedures at 1500 Hours or 1 Year	7
Maintenance Procedures at 4500 Hours	8
Maintenance Procedures at 4500 Hours or 3 Years	9
Maintenance Procedures at 6000 Hours or 3 Years	10
Adjustment, Repair, and Replacement	A
System Diagrams	D
Engine Storage	ES
Service Literature	L
Service Assistance	S
Troubleshooting Symptoms	TS
Maintenance Specifications	V
Warranty	W
Back	back

Engine Identification

Engine Dataplate

Model	MEP Type Approval Certificate Compliance Stage X Emission on Standards			
Engine Serial NO. XXXXXXXX	Certification Type Approval No. XXXXXXXXXXXXXXXXX			
Rated Power/Speed XXX KW/XXX rpm	Net Weight	Shop Order SCXXXX	QSD	CPL No.
Beijing Foton Cummins Engine Co., Ltd. Beijing China	WARNING: Injury may result and warranty is voided if fuel rate, rpm or altitudes exceed published maximum values for this model and application.			Date of Mfg XXXX-XX

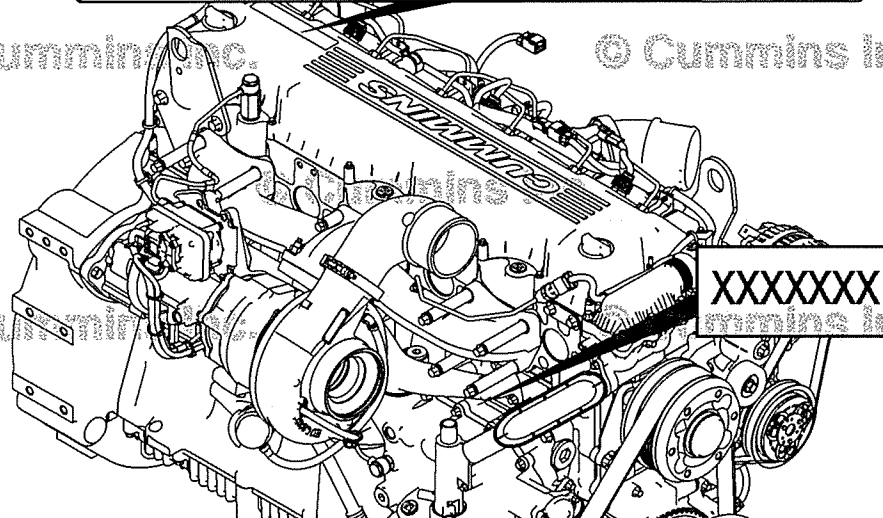

00p00053

The engine dataplate provides important facts about the engine. The dataplate is typically located on the engine rocker lever cover, but may also be located on the side of the gear housing. The engine serial number (ESN) and control parts list (CPL) provide data for ordering parts and service. The engine dataplate **must not** be changed unless approved by Cummins Inc.

Have the following engine data available when communicating with a Cummins® Authorized Repair Location. The information on the dataplate is mandatory when sourcing service parts.

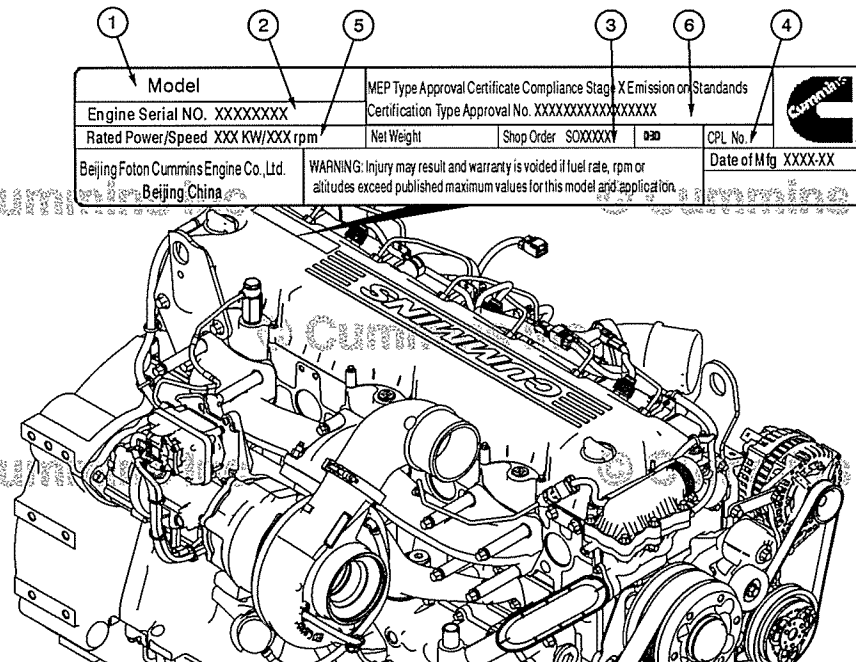

00p00054

- 1 Engine model information
- 2 Engine serial number (ESN)
- 3 Shop Order (SO)
- 4 Control parts list (CPL)

Engine Diagrams

Engine Views

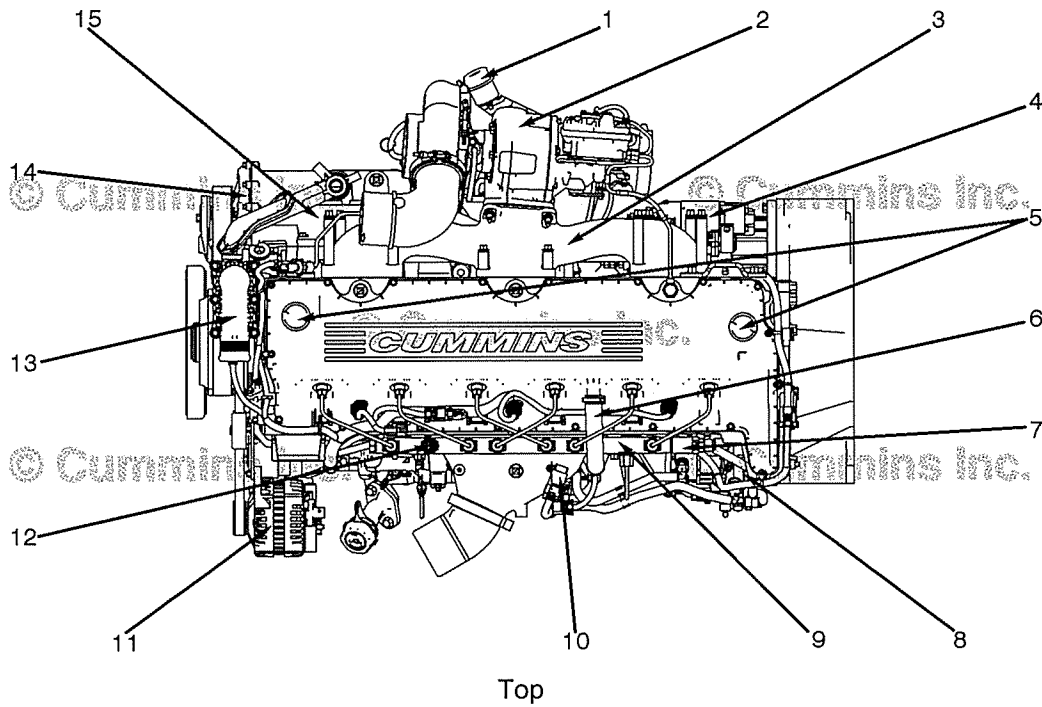

00p00063

- 1 Turbocharger wastegate control valve
- 2 Turbocharger
- 3 Exhaust manifold
- 4 Starter
- 5 Oil fill cap
- 6 Crankcase breather tube
- 7 Fuel rail pressure relief valve
- 8 Hydraulic drive adaptor
- 9 Fuel rail
- 10 Intake manifold pressure/temperature sensor
- 11 Alternator
- 12 Fuel rail pressure sensor
- 13 Dual thermostat housing
- 14 Water pump
- 15 Lubricating oil cooler module.

- A three-position switch that is used to activate manual (non-mission) regeneration and also disable active regeneration.

The examples below are generic and show two typical switch configurations. Use the vehicle owner's manual for the location and presence of these switches.

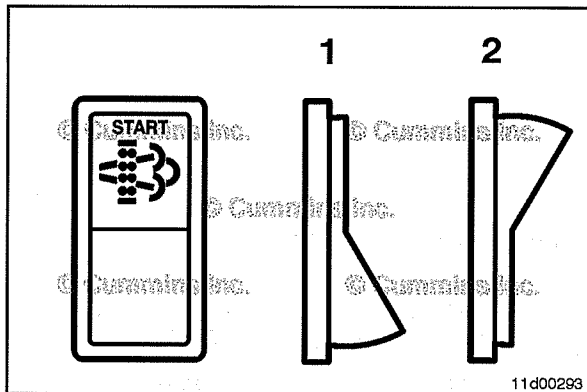

A two-position switch (ON and OFF positions) will, when in the ON position (1), activate a manual (non-mission) regeneration.

The switch should be left in the OFF position (2) when the switch is **not** being used.

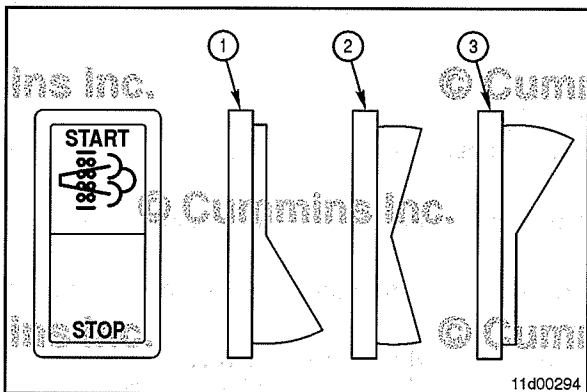

A three-position switch (ON, NEUTRAL, and OFF positions) will typically have both START and PERMIT functions.

In the ON position (1), the START switch is depressed, which will activate a manual (non-mission) regeneration.

In NEUTRAL position (2), neither the START switch or PERMIT switch is depressed as the switch is in the NEUTRAL position. This position is recommended for normal engine operation.

In OFF position (3), the PERMIT switch is depressed. When the switch is in this position, active regeneration of the aftertreatment system will **not** be allowed.

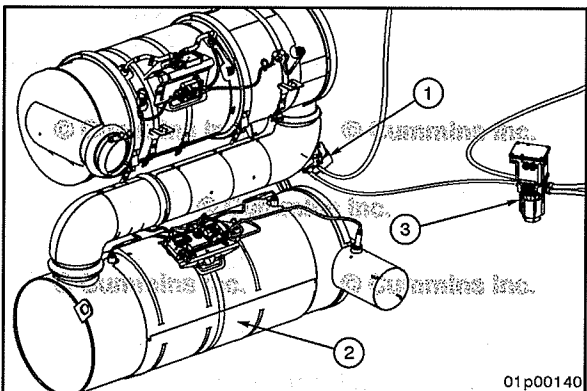

Unique Operating Characteristics of an Engine with Airless Selective Catalytic Reduction (SCR)

General Information

The selective catalytic reduction (SCR) system is used to decrease the NOx emissions from the vehicle tailpipe. The system is composed of several main components:

- 1 Aftertreatment diesel exhaust fluid (DEF) dosing valve
- 2 Aftertreatment SCR catalyst
- 3 Aftertreatment DEF dosing unit.

NOTE: It is unlawful to tamper with, modify, or remove any component of the SCR system. It is also unlawful to use DEF that does **not** meet the specifications provided, or to operate the vehicle/equipment with no DEF.

Remove

⚠ WARNING ⚠

Depending on the circumstance, diesel fuel is flammable. When inspecting or performing service or repairs on the fuel system, to reduce the possibility of fire and resulting severe personal injury, death, or property damage, never smoke or allow sparks or flames (such as pilot lights, electrical switches, or welding equipment) in the work area.

See equipment manufacturer service information for information regarding the removal of the suction side fuel filter.

NOTE: Suction-side fuel filters are OEM supplied. See equipment manufacturer service information for appropriate service intervals.

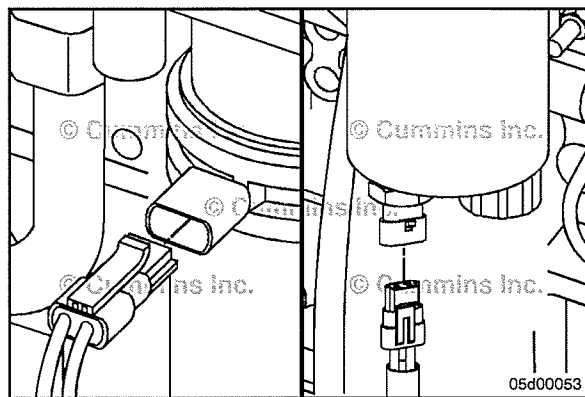

Install

Use the correct filter(s) for your engine. The suction side fuel filter **must** remove a minimum of 95 percent of free and emulsified water. It **must** also have a 5-micron particle removal efficiency.

See equipment manufacturer service information for information regarding proper installation of the suction-side fuel filter.

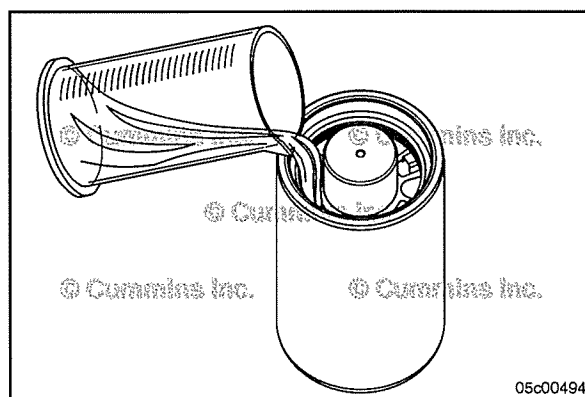

Finishing Steps

⚠ WARNING ⚠

Batteries can emit explosive gases. To reduce the possibility of personal injury, always ventilate the compartment before servicing the batteries. To reduce the possibility of arcing, remove the negative (-) battery cable first and attach the negative (-) battery cable last.

- Connect the batteries. See equipment manufacturer service information.
- Prime the fuel system. Refer to Procedure 005-234 in Section A.
- Operate the engine and check for leaks.

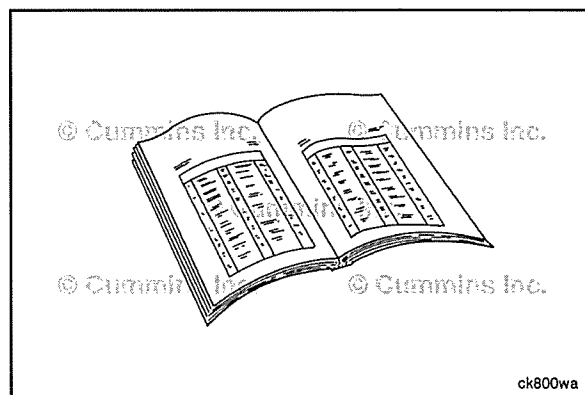

Spin the tensioner pulley. The pulley **must** spin freely. If pulley does **not** spin freely, replace the belt tensioner.

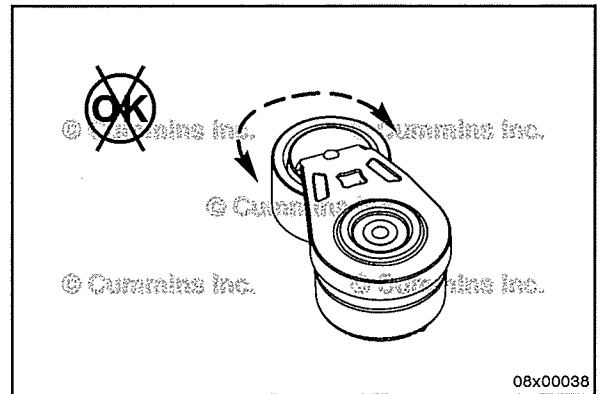

Inspect the belt tensioner for evidence of the tensioner pivoting arm contacting the stationary circular base of the tensioner or the fan shroud bracket. If so, the pivot bushing is excessive worn. Replace the belt tensioner.

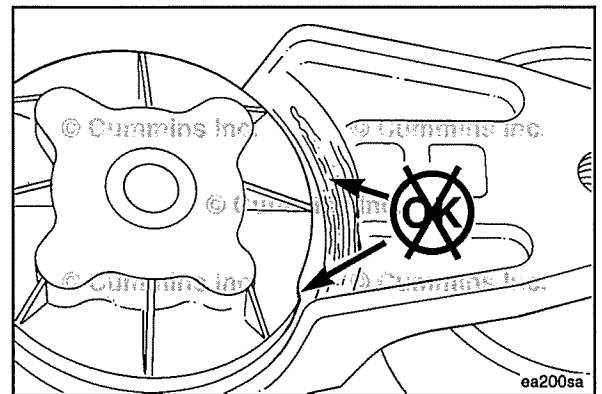

Inspect bracket for cracks or damages. Replace if damaged.

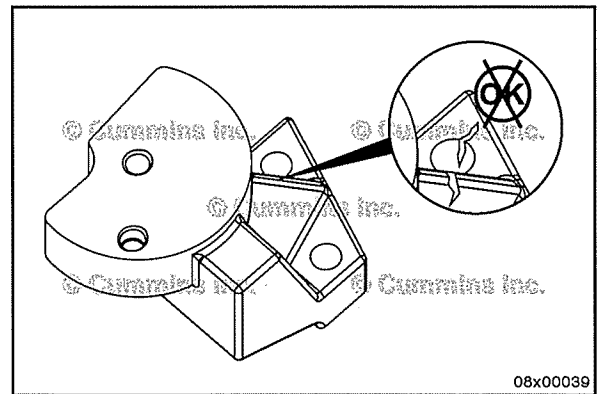

Install

Install the fan shroud bracket and mounting bracket capscrews.

Tighten the capscrew.

Torque Value: 55 N•m [41 ft-lb]

Install the belt tensioner and capscrew.

Tighten the capscrew.

Torque Value: 55 N•m [41 ft-lb]

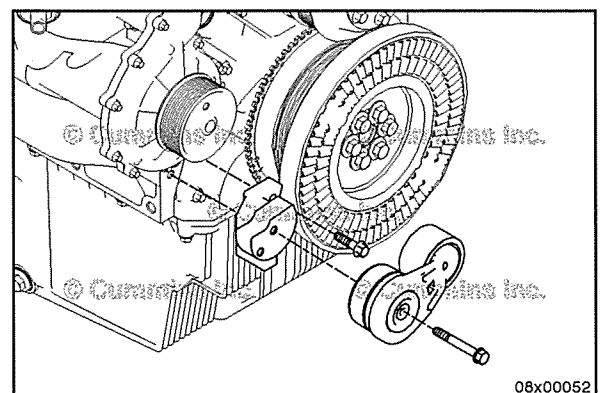

Crankshaft Pulley Preparatory Steps

⚠ WARNING ⚠

Batteries can emit explosive gases. To reduce the possibility of personal injury, always ventilate the compartment before servicing the batteries. To reduce the possibility of arcing, remove the negative (-) battery cable first and attach the negative (-) battery cable last.

- Disconnect the batteries. Refer to Procedure 013-009 in Section A.
- Remove the cooling fan drive belt. Refer to Procedure 008-002 in Section A.

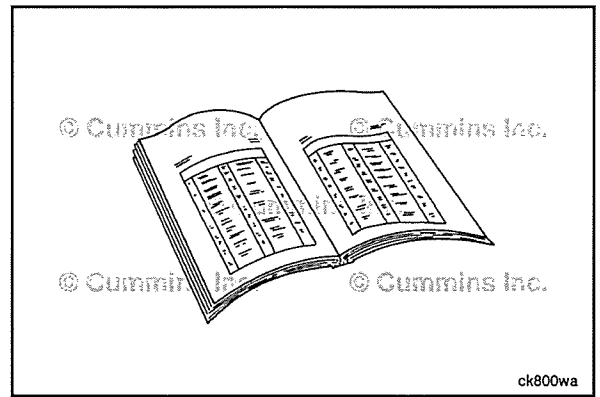

Remove

Remove two capscrews and insert guide pins, Part Number 3376696, to support the damper.

Remove the other four capscrews.

Remove the vibration damper, crankshaft pulley, and crankshaft spacer.

NOTE: The crankshaft speed indicator ring is an integral part of the crankshaft pulley that can **not** be separated.

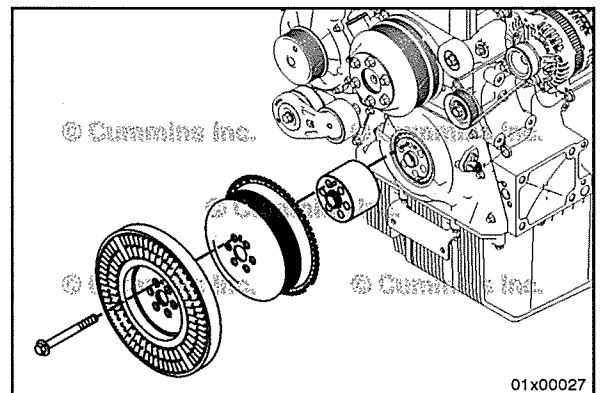

Clean and Inspect for Reuse

⚠ WARNING ⚠

Wear appropriate eye and face protection when using compressed air. Flying debris and dirt can cause personal injury.

Use soapy water to clean any oil from the crankshaft pulley.

Dry the crankshaft pulley with compressed air.

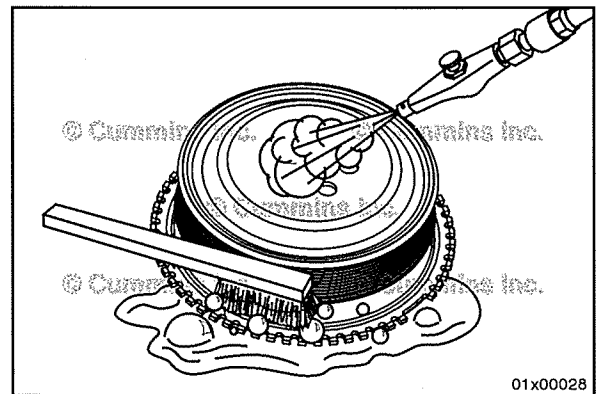

Inspect the crankshaft speed indicator ring for missing teeth, cracks, or damaged surfaces.

If any damage is found, the crankshaft pulley **must** be replaced.

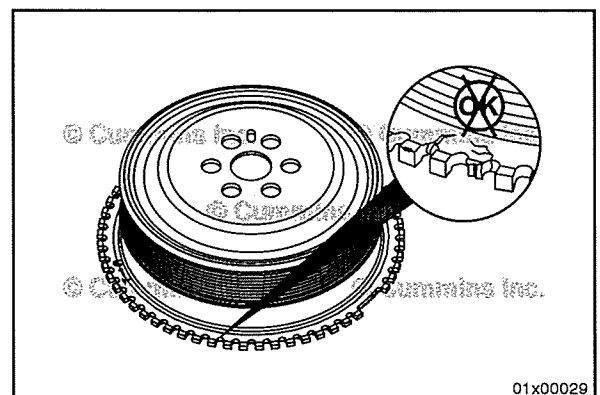

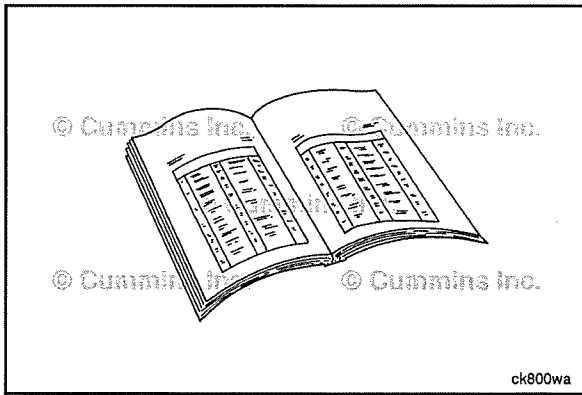

Preparatory Steps



▲ WARNING ▲

Diesel exhaust fluid (DEF) contains urea. Do not get the substance in your eyes. In case of contact, immediately flush eyes with large amounts of water for a minimum of 15 minutes. Do not swallow. In the event the DEF is ingested, contact a physician immediately. Reference the materials safety data sheet (MSDS) for additional information.

▲ WARNING ▲

Batteries can emit explosive gases. To reduce the possibility of personal injury, always ventilate the compartment before servicing the batteries. To reduce the possibility of arcing, remove the negative (-) battery cable first and attach the negative (-) battery cable last.

▲ WARNING ▲

The diesel exhaust fluid (DEF) line connecting the aftertreatment diesel exhaust fluid dosing unit to the aftertreatment diesel exhaust fluid dosing valve is under low pressure and should not be disconnected while the engine is running or before the system has completed the purge process after engine shutdown. Disconnecting the DEF line while under low pressure could cause DEF to spray.

▲ WARNING ▲

Wear appropriate eye and face protection when using compressed air. Flying debris and dirt can cause personal injury.

NOTE: Do **not** power wash or steam clean this unit. Use compressed air to remove any loose debris.

- Disconnect the batteries. See equipment manufacturer service information.

NOTE: The dosing unit around the filter housing **must** be cleaned using a clean damp cloth, warm water, and a mild detergent.

- Use a clean damp cloth to remove any contamination, to reduce the risk of contaminants entering the DEF dosing unit.

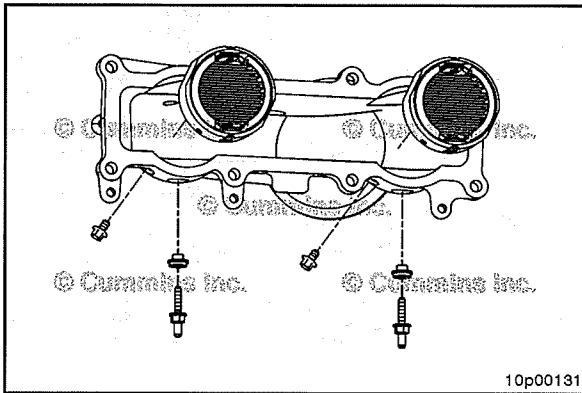

Remove electrical supply studs and spacers.

Remove ground capscrews.

Remove the cylindrical cold starting aid assemblies from the air intake connection.

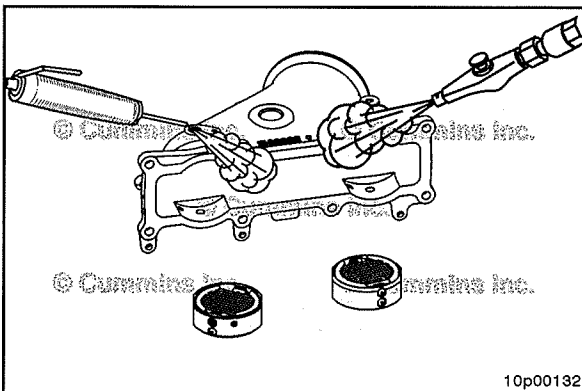

Clean and Inspect for Reuse

⚠ WARNING ⚠

When using a steam cleaner, wear safety glasses or a face shield, as well as protective clothing. Hot steam can cause serious personal injury.



⚠ WARNING ⚠

Wear appropriate eye and face protection when using compressed air. Flying debris and dirt can cause personal injury.

Use heavy tape from the Air Handling Clean Care Kit, Part Number 4919588, to cover open points on the plumbing and engine.

Steam clean the air intake connection.

Steam clean the cold starting aids, and electrical connection. Dry with compressed air.

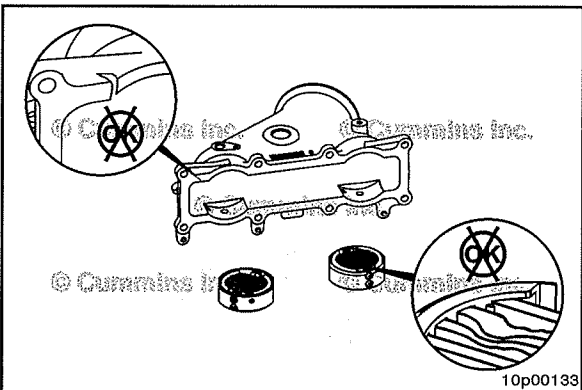

Inspect the cold starting aid and air intake connection sealing surfaces for cracks or other damage.

Replace any damaged components.

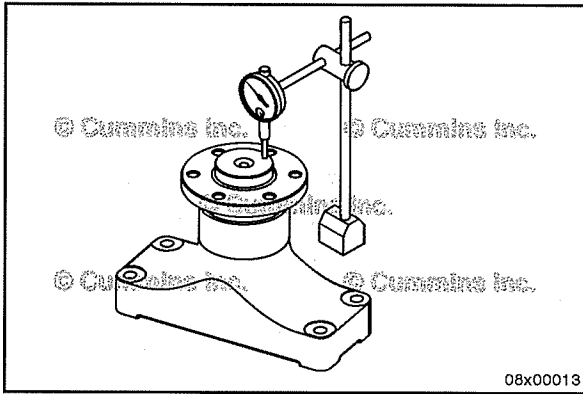

Inspect the fan hub bearing for wear.

The bearing **must** have a minimal amount of side-to-side or end-play movement.



Replace the fan hub if there is more than 0.15 mm [0.006 in] of end play in the fan hub. Measure end play with a dial indicator, service tool Part Number 3376050.

Fan Hub End Play

mm		in
0.15	MAX	0.006

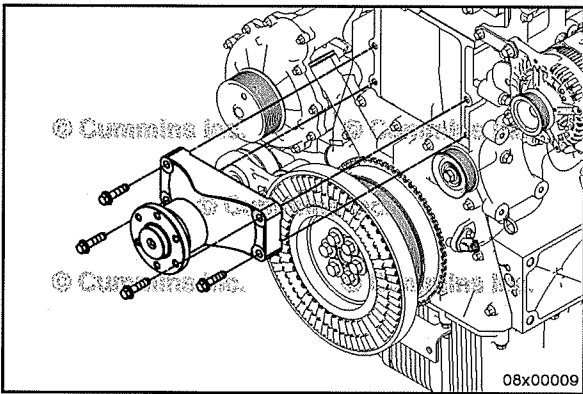

Install

Install the fan hub and four cap screws.



Torque Value: 46 N•m [34 ft-lb]

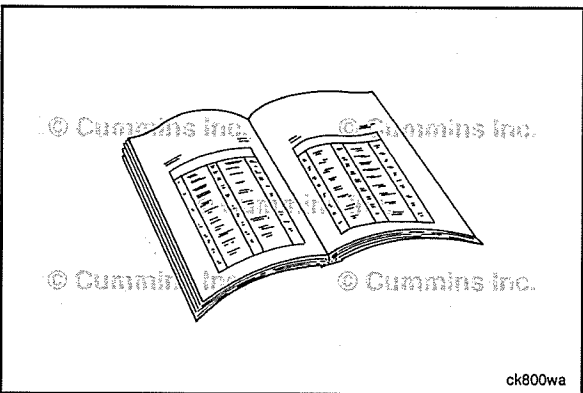

Finishing Steps

▲ WARNING ▲



Batteries can emit explosive gases. To reduce the possibility of personal injury, always ventilate the compartment before servicing the batteries. To reduce the possibility of arcing, remove the negative (-) battery cable first and attach the negative (-) battery cable last.



NOTE: Some applications do **not** have a cooling fan or the cooling fan is located elsewhere on the application.

- Install the fan pulley and spacer. Refer to Procedure 008-089 in Section A.
- Install the cooling fan. See equipment manufacturer service information.
- Install the drive belt. Refer to Procedure 008-002 in Section A.
- Connect the batteries. See equipment manufacturer service information.
- Operate the engine and check for proper operation.

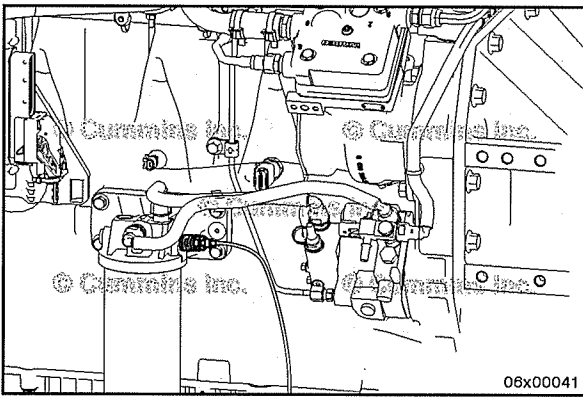

To assist in fuel system priming and removing air from the fuel system, an orificed diagnostic fuel line, Part Number 3164621, may be used to bleed air from the low-pressure fuel system.



Install a Compuchek™ fitting, Part Number 3824844, at the inlet to the pressure-side fuel filter.



Attach the diagnostic fuel line to the Compuchek™ fitting at the inlet to the pressure-side fuel filter. Crank or start the engine and allow it to run until the air is removed from the fuel system and a solid stream of fuel exits the diagnostic fuel line.

Stop the engine after a solid stream of fuel begins exiting the diagnostic fuel line. Wait 4 to 5 seconds to allow any compressed air trapped in the fuel filter head to exit through the diagnostic fuel line.

Repeat this process until air no longer exits the diagnostic fuel line when cranking or starting the engine. If air continues to exit the diagnostic fuel line after four or more repetitions, check the suction side of the fuel system for leaks. Refer to Procedure 006-003 in Section A.

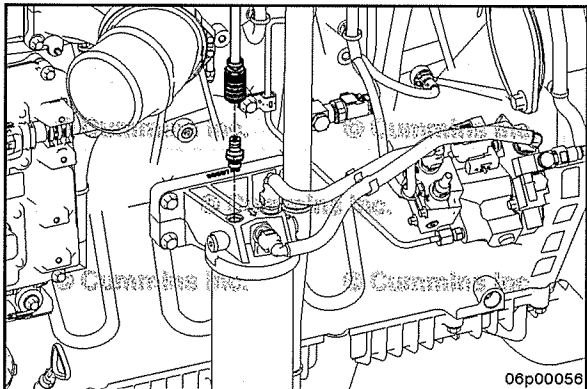

Air in Fuel Setup

Install a Compuchek™ fitting, Part Number 3824844, at the outlet to the fuel filter head.

Install orificed diagnostic fuel line, Part Number 3164621, onto the Compuchek™ fitting at the inlet to the pressure side fuel filter.

The orificed diagnostic fitting is used in procedures to create rated flow through the low pressure fuel system without the need to operate the engine under load.

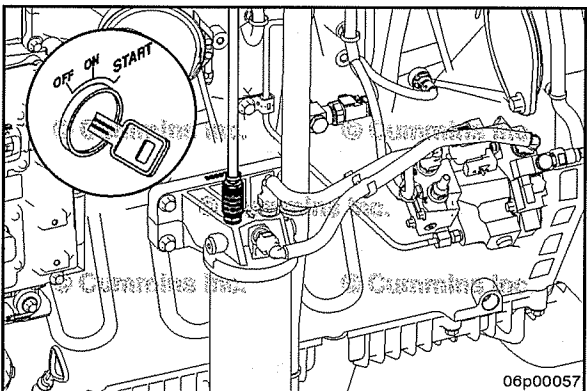

Measure

NOTE: A symptom of air-in-fuel for the engines equipped with a common rail fuel system is an audible surge associated with fuel system pressure fluctuations, due to air in the fuel supply.

Battery Cables and Connections

Initial Check

There are two possible heavy-duty battery connections:

- Battery terminal and clamp (1)
- Threaded battery terminal and nut (2).

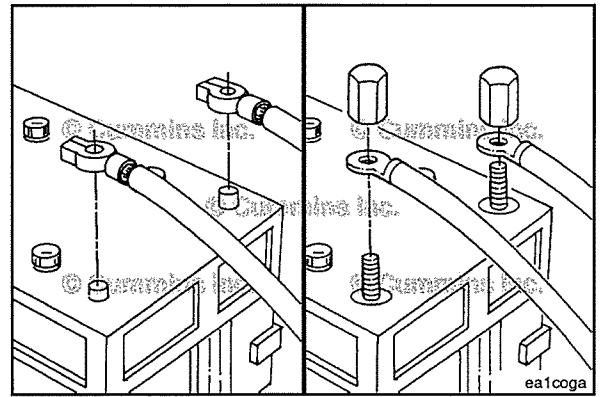

⚠ WARNING ⚠

Batteries can emit explosive gases. To reduce the possibility of personal injury, always ventilate the compartment before servicing the batteries. To reduce the possibility of arcing, remove the negative (-) battery cable first and attach the negative (-) battery cable last.

Remove and inspect the battery cables and connections for cracks or corrosion.

Replace broken terminals, connectors, or cables.

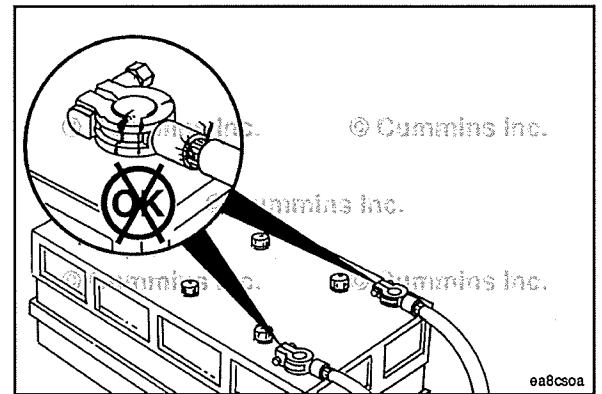

If the connections are corroded, use a battery brush or wire brush to clean the connections until shiny.

Make sure all debris is removed from the connecting surfaces.

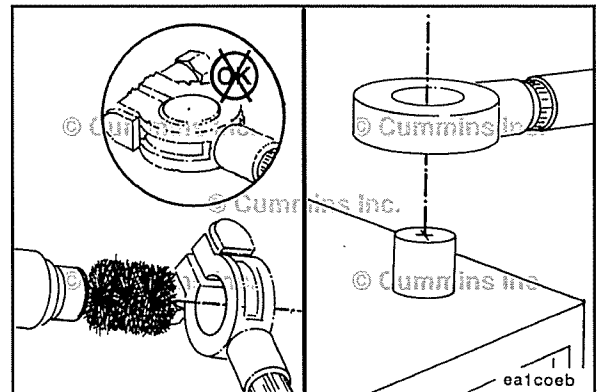

⚠ WARNING ⚠

Batteries can emit explosive gases. To reduce the possibility of personal injury, always ventilate the compartment before servicing the batteries. To reduce the possibility of arcing, remove the negative (-) battery cable first and attach the negative (-) battery cable last.

Install the cables and tighten the battery connections.

Coat the terminals with grease to prevent corrosion.

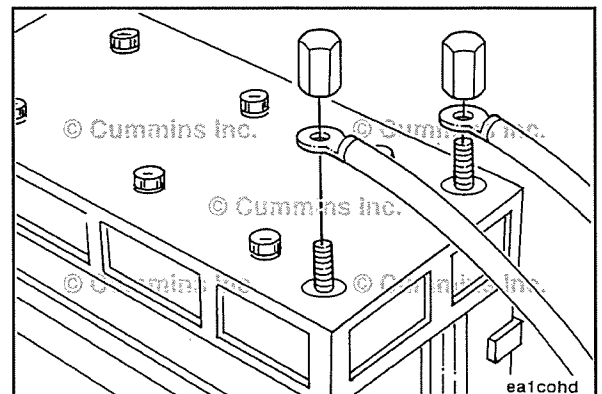

Flow Diagram, Exhaust System

General Information

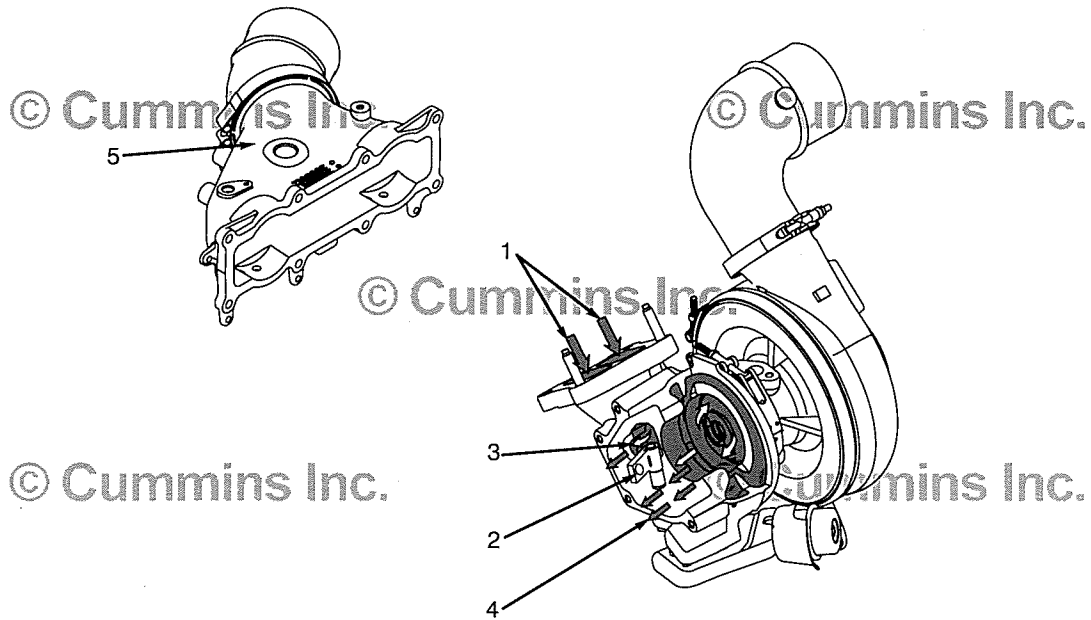

11p00124

Wastegate Open (High Intake Manifold Pressure)

- 1 Exhaust flow from exhaust manifold
- 2 Wastegate open
- 3 Some exhaust flow bypassing the turbine
- 4 Turbocharger exhaust outlet
- 5 Intake manifold.

Cummins Customized Parts Catalog

General Information

Cummins is pleased to announce the availability of a parts catalog compiled specifically for you. Unlike the generic versions of parts catalogs that support general high volume parts content; Cummins Customized catalogs contain only the new factory parts that were used to build your engine.

The catalog cover, as well as the content, is customized with you in mind. You can use it in your shop, at your worksite, or as a coffee table book in your RV or boat. The cover contains your name, company name, address, and telephone number.

This new catalog was designed to provide you with the exact information you need to order parts for your engine. This will be valuable for customers that do not have easy access to Cummins QuickServe Online.

Additional Features of the Customized Catalog include:

- Engine Configuration Data
- Table of Contents
- Separate Option and Parts Indexes
- Service Kits (when applicable)
- ReCon Part Numbers (when applicable)

Ordering the Customized Parts Catalog

Ordering by Telephone

- North American Distributors, Original Equipment Manufacturers and Cummins Factory personnel order by calling Iron Mountain Fulfillment Services (IMFS) at 1-800-646-5609.
- International Distributors and Original Equipment Manufacturers order the CPC from their regional Cummins Parts Distribution Centers (PDC).
- International PDC orders are called into Iron Mountain at (++) 630-283-2420.
- Retail Credit Card Orders require a 2 step ordering process.

Ordering On-Line

Access the Cummins QSOL store at <https://store.cummins.com>

- Find the Customized Parts Catalog button located on the left of the homepage
- Select format. Your Price is also shown here
- Finalize Shopping Cart and Check Process as described on the website

North America call Iron Mountain Fulfillment Services (IMFS) at 800-646-5609, International customers call (++) 630-283-2420. Provide IMFS the catalog detail as described on the website. This step is required until we have our On Line form available.

Required information needed for your Customized Parts Catalog Order.

- Customer Name
- Street Address
- Company Name (optional)
- Telephone no.
- Credit Card No.
- Cummins Engine Serial Number (located on the engine data plate)

Unfortunately not all Cummins Engines can be supported by Customized Parts Catalogs. Engines older than 1984 or newer than 3 months may not have the necessary parts information to compile a catalog. We will contact you if this occurs and explain why we are unable to fill your order.

Customized Parts Catalogs are produced specifically for a single customer. This means they are not returnable for a refund. If we make an error and your catalog is not useable, we will correct that error by sending you a new catalog.