

# Table of Contents

---

**Section**

---

Introduction .....	i
Engine Identification .....	E
Industrial Features .....	FB
Operating Instructions .....	1
Maintenance Guidelines .....	2
Maintenance Procedures at Daily Interval .....	3
Maintenance Procedures at 250 Hours or 3 Months .....	4
Maintenance Procedures at 500 Hours or 6 Months .....	5
Maintenance Procedures at 1000 Hours or 1 Year .....	6
Maintenance Procedures at 2000 Hours or 2 Years .....	7
Maintenance Procedures at 5000 Hours or 4 Years .....	8
Adjustment, Repair, and Replacement .....	A
System Diagrams .....	D
Service Literature .....	L
Component Manufacturers .....	M
Service Assistance .....	S
Troubleshooting Symptoms .....	TS
Maintenance Specifications .....	V
Warranty .....	W



## Engine Identification

### Engine Dataplate

 <b>Cummins Engine Company, Inc.</b> Columbus, Indiana 47202-3005 <small>Warning: Injury May Result And Warranty is Voided if Fuel Rate Or Altitudes Exceed Published Maximum Values For This Model And Application.</small> Date of Mfg. _____ Made In U.S.A. _____	Engine Cert. ID#	C.I.D./ L	SERIES	CPL	Engine Serial No.
	Timing TDC	Valve lash cold	Inl.	Exh.	Rated HP
	Firing Order	Low Idle RPM	E.C.S.		Model Name
	Injector P/N	Cust. Spec.		Exhaust Temp	at
	Exhaust Temp	Fuel rate at rated HP		mm 3/stroke	
	Exhaust Temp	Fuel rate at rated HP		mm 3/stroke	
	Exhaust Temp	Fuel rate at rated HP		mm 3/stroke	

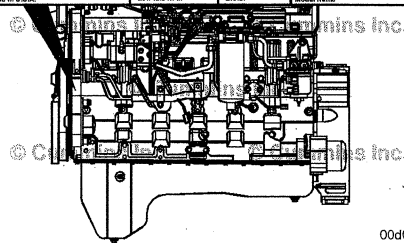

00d00001

The engine dataplate provides important facts about the engine. The engine serial number (ESN) and control parts list (CPL) provide information for service and ordering parts. The engine dataplate **must not** be changed unless approved by Cummins Inc.

 <b>Cummins Engine Company Inc</b> Columbus, Indiana 47202-3005 <small>Warning: Injury May Result And Warranty is Voided if Fuel Rate Or Altitudes Exceed Published Maximum Values For This Model And Application.</small> Date of Mfg. 19951130 Made In U.S.A. 3906610	Engine Cert. I.D.	C.I.D./ L	SERIES	CPL	Engine Serial No. 45275188
	Timing TDC	Valve lash cold	Inl.	Exh.	Rated HP
	Firing Order	Low Idle RPM	E.C.S.		Model Name
	Injector P/N	Cust. Spec.		Exhaust Temp	at
	Exhaust Temp	Fuel rate at rated HP		mm 3/stroke	
	Exhaust Temp	Fuel rate at rated HP		mm 3/stroke	
	Exhaust Temp	Fuel rate at rated HP		mm 3/stroke	

00900061

The dataplate is located on the top side of the gear housing.

Have the following engine data available when communicating with a Cummins Authorized Repair Location:

1. Engine serial number (ESN)
2. Control parts list (CPL)
3. Model
4. Horsepower and rpm rating.

If the engine dataplate (1) is **not** readable, the ESN (2) can be found on the engine block on top of the lubricating oil cooler housing. Additional engine information is on the electronic control module (ECM) dataplate.

 <b>Cummins Engine Company, Inc.</b> Columbus, Indiana 47202-3005 <small>Warning: Injury May Result And Warranty is Voided if Fuel Rate Or Altitudes Exceed Published Maximum Values For This Model And Application.</small> Date of Mfg. _____ Made In U.S.A. _____	Engine Cert. ID#	C.I.D./ L	SERIES	CPL	Engine Serial No.
	Timing TDC	Valve lash cold	Inl.	Exh.	Rated HP
	Firing Order	Low Idle RPM	E.C.S.		Model Name
	Injector P/N	Cust. Spec.		Exhaust Temp	at
	Exhaust Temp	Fuel rate at rated HP		mm 3/stroke	
	Exhaust Temp	Fuel rate at rated HP		mm 3/stroke	
	Exhaust Temp	Fuel rate at rated HP		mm 3/stroke	

00d00003

## Visual Aids

None

## Fan Control

### Feature Description

Various fan control features are available and while **not** all aspects of fan control are available on all engines, most (but **not** all) electronic controlled engines have some Electronic Control Module (ECM) fan control capability.

Fan control capability means that the ECM is able to turn the fan on or off in response to any of the following inputs:

- Engine operating conditions (coolant temperature, intake manifold temperature, etc.)
- Control of fan overspeed
- Air conditioner operation
- Manual fan switch
- Engine performance requirements (Example: engine braking)

**NOTE:** Many Industrial engines have fan controls as part of the ECM calibration that can **not** be adjusted using the service tool.

### Driver Activation/Deactivation

The driver can override the ECM to turn the fan on, using the manual fan switch installed in the cab by the vehicle manufacturer. When the driver places the manual fan switch in the ON position, the fan will be on regardless of other engine operating conditions. When the manual fan switch is in the OFF position, the fan will operate according to engine operating conditions and according to how the fan control parameters are configured.

### Interaction with other Features and Parameters

ISB and ISC have a single pin on the ECM that provides Pulse Width Modulation. This pin can be used to send a kick-down signal to an automatic transmission, in which case it **must not** be used to operate a variable speed fan.

### Disadvantages

Due to heat rejection, the fan on during engine braking feature will appear inconsistent to some vehicle operators (Example: Consider an ISX calibration setting that the fan will engage 15 seconds after engine braking starts. It will be possible for the fan to sometimes come on sooner in response to air intake temperatures, coolant temperatures, or the air conditioner pressure switch).

### Visual Aids

1. Fan Type
2. Drive Ratio
3. Maximum Fan Speed
4. Air Conditioner Speed Control
5. Fan On During Engine Braking
6. Minimum Fan On Time for Air Conditioner Pressure Switch
7. Manual Fan Switch
8. Air Conditioner Pressure Switch
9. Pulse Width Modulation Frequency
10. Clutch Logic
11. Fan Clutch 2 Enable

## Hot Shutdown Monitor

### Feature Description

The Hot Shutdown Monitor will log a fault in the Electronic Control Module (ECM) if the engine is shut down, either by the key switch or by the engine protection feature or other Original Equipment Manufacturer (OEM) devices, while still hot. The engine is considered hot if the load on the engine is above the hot shutdown minimum load set by Cummins INSITE™ electronic service tool. Hot shutdown monitor is available on QSB, QSC, QSL9, QSM11, QSX15, QST30, QSK19, QSK45, QSK50, QSK38, QSK78, and QSK60 industrial engines.

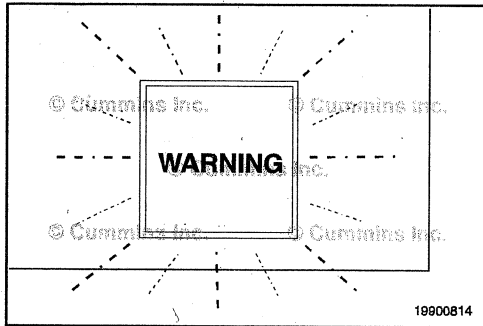

## Engine Protection System

### ⚠ CAUTION ⚠

When the red STOP lamp is illuminated, the driver must pull to the side of the road, once it is safe to do so, to reduce the possibility of engine damage.

The QSC8.3 engines are equipped with an engine protection system. The system monitors critical engine temperatures and pressures, and will log diagnostic faults when an over or under normal operation condition occurs. If an out-of-range condition exists, and engine derate action is to be initiated, the operator will be alerted by an in-cab WARNING lamp. The WARNING lamp will blink or flash when out-of-range conditions continue to get worse. When the red STOP lamp is illuminated, the driver **must** pull to the side of the road, when it is safe to do so, to reduce the possibility of engine damage.

The engine protection system monitors the following data:

- Coolant temperature
- Coolant level (optional)
- Oil pressure
- Intake manifold temperature
- Engine overspeed
- Fuel temperature.
- OEM pressure (optional)

**NOTE:** Engine power and speed will gradually reduce depending on the severity of the observed condition. The engine protection system will **not** shut down the engine unless the engine protection shutdown feature has been enabled.

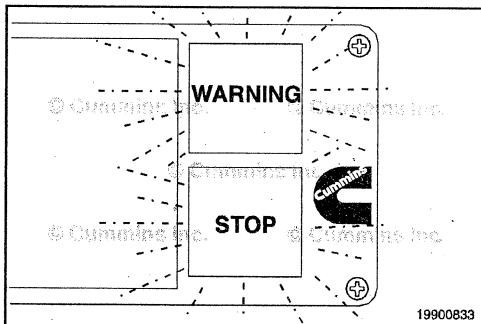

### Engine Protection Shutdown

This feature automatically shuts off the engine when the temperature, pressure, or coolant level sensors indicate the engine is operating over or under normal operating conditions.

The red "STOP" lamp in the cab will flash for 30 seconds prior to shutdown to alert the driver.

The engine protection shutdown feature can be enabled or disabled using the INSITE™ electronic service tool if the feature is available in the calibration.

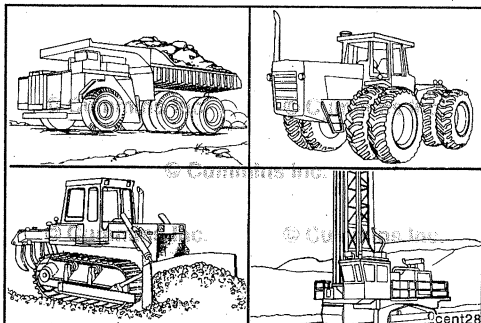

## Programmable Features

The electronic control system can provide many features that are integrated into the vehicle's operation. Some of these features can be adjusted or turned on and off with a service tool, but some are set at the factory and can **not** be changed.

The following section describes the functionality of each feature and whether an available feature in a given application is calibration-dependent.

- Parameters:**
- User-activated datalogger enable
  - Trigger No. 1
  - Trigger No. 2
  - Trigger type
  - Fault code trigger
  - Fault code trigger when
  - Parameter trigger
  - Parameter trigger when
  - Parameter limit value
  - Activation mode
  - Sampling rate
  - Parameters to log
- 19d00585

#### User-Activated Datalogger

The purpose of this feature is to enable the electronic control module (ECM) to log selectable data parameters on request. This snapshot request can be initiated either by an operator-controlled diagnostic switch or automatically based on a set of selectable trigger points. The electronic control module (ECM) will store, to nonvolatile memory, a maximum of two snapshot events. Half of the data for each snapshot event will consist of pretrigger data, and the other half will be posttrigger data. The INSITE™ electronic service tool will provide a list of loggable data parameters and trigger points for the user to select. In addition, the INSITE™ electronic service tool will allow the user to select the time interval for data parameter sampling and choose manual or automatic triggers. This feature has the potential to decrease equipment downtime due to improved troubleshooting capabilities as well as providing assistance in troubleshooting intermittent problems. Also, in the diagnostic switch mode, an operator can capture data while a problem is occurring, so service personnel can analyze the data at a later time.

#### Parameters:

- User-activated datalogger enable
- Trigger No. 1
- Trigger No. 2
- Trigger type
- Fault code trigger
- Fault code trigger when
- Parameter trigger
- Parameter trigger when
- Parameter limit value
- Activation mode
- Sampling rate
- Parameters to log.

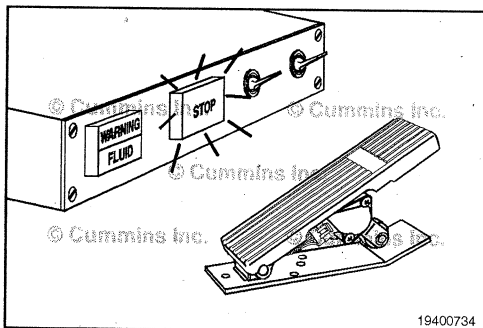

#### Throttle-Activated Diagnostic Switch

Throttle-activated diagnostic switch is intended to eliminate the need for a dash-mounted diagnostic switch, which is used to activate the diagnostic mode to display active fault codes in a sequence of flashing lamps. The throttle-activated diagnostic switch feature eliminates the need for a dash-mounted diagnostic switch by providing a simple sequence of throttle movements that activate the diagnostic mode.

**NOTE:** The feature will work with all throttle types.

**NOTE:** In order to reset the maintenance monitor data, a diagnostic switch **must** be installed.

<b>Table 1, Oil Drain Intervals</b>				
<b>Vehicle/Equipment</b>	<b>Kilometers</b>	<b>Miles</b>	<b>Hours</b>	<b>Months</b>
Truck Crane/Yard Spotter	14,500	9000	500	6
Paver/Crane/Skidder	N/A	N/A	500	6
Dozer/Scraper/Skidder	N/A	N/A	500	6

<b>Table 2, Oil Drain Intervals</b>				
<b>Vehicle/Equipment</b>	<b>Kilometers</b>	<b>Miles</b>	<b>Hours</b>	<b>Months</b>
Tractor/Combine/Irrigation Equipment	N/A	N/A	500	6
Genset/Air Compressor/Fire Pump	N/A	N/A	500	6

<b>Table 3, Oil Drain Intervals</b>				
<b>Vehicle/Equipment</b>	<b>Kilometers</b>	<b>Miles</b>	<b>Hours</b>	<b>Months</b>
All Others	14,500	9000	500	6

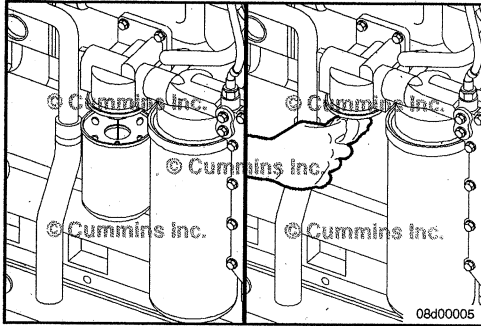

**▲ WARNING ▲**

A small amount of coolant can leak when servicing the coolant filter with the shutoff valve in the OFF position. To reduce the possibility of personal injury, avoid contact with hot coolant.



**▲ WARNING ▲**

Coolant is toxic. Keep away from children and pets. If not reused, dispose of in accordance with local environmental regulations.

Remove and discard the coolant filter.

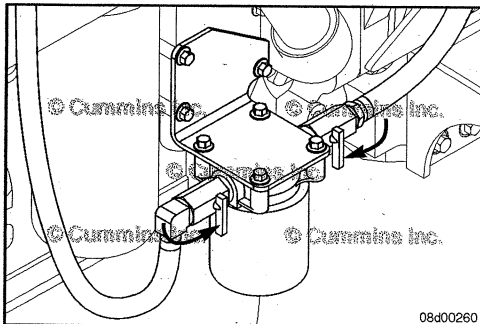

**Marine Applications**

**▲ WARNING ▲**

Do not remove the pressure cap from a hot engine. Wait until the coolant temperature is below 50°C [120°F] before removing the pressure cap. Heated coolant spray or steam can cause personal injury.

**NOTE:** It is possible that some marine engine models do not have coolant filters.

Remove the coolant system pressure cap.

Turn the inlet and outlet shutoff valves to the OFF position by rotating the knobs from the horizontal to the vertical direction as shown.

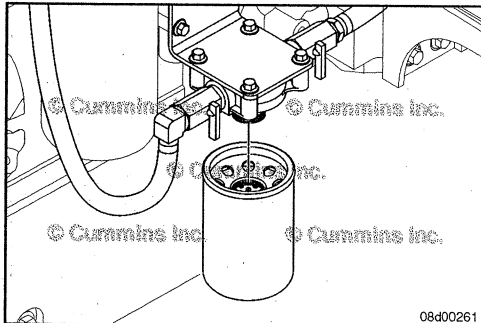

**▲ WARNING ▲**

A small amount of coolant can leak when servicing the coolant filter with the shutoff valve in the OFF position. To reduce the possibility of personal injury, avoid contact with hot coolant.

**▲ WARNING ▲**

Coolant is toxic. Keep away from children and pets. If not reused, dispose of in accordance with local environmental regulations.

**▲ CAUTION ▲**

Use caution when draining coolant that coolant is not spilled or drained into the bilge area. Do not pump the coolant overboard. If the coolant is not reused, it must be discarded in accordance with local environmental regulations.

Remove and discard the coolant filter.

Fill the cooling system with clean water.

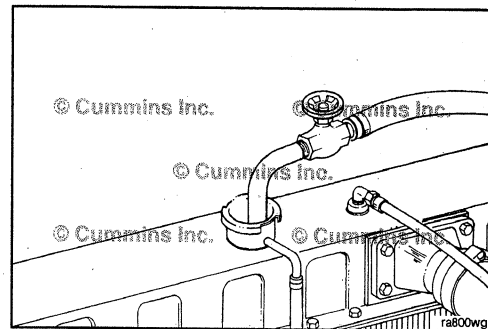

**▲ WARNING ▲**

Do not remove the pressure cap from a hot engine. Wait until the coolant temperature is below 50°C [120°F] before removing the pressure cap. Heated coolant spray or steam can cause personal injury.



**▲ WARNING ▲**

Coolant is toxic. Keep away from children and pets. If not reused, dispose of in accordance with local environmental regulations.

Operate the engine at high idle for five minutes with the coolant temperature above 85°C [185°F].

Shut off the engine and drain the cooling system.

If the water being drained is still dirty, the system **must** be continually flushed until the water is clean.

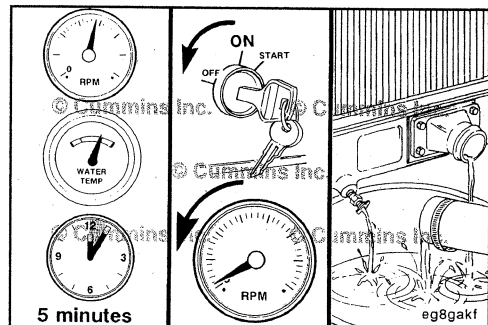

**Fill**

Close the radiator draincocks.

Install the lower radiator hose(s).

Tighten the hose clamps.

**Torque Value:** 5 N•m [ 44 in-lb ]

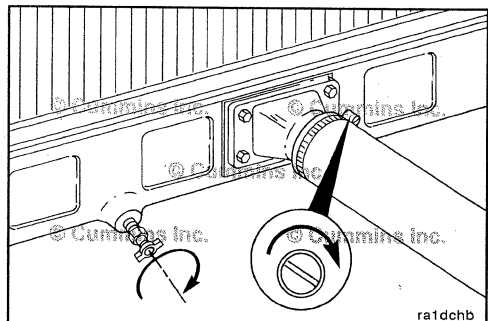

The system is designed to use a specific quantity of coolant. If the coolant level is low, the engine will run hot.

If the addition of coolant is necessary, the engine or system has a leak. Find and repair the leak.

The system has a designed fill rate of 19 liters [5 gal] per minute.

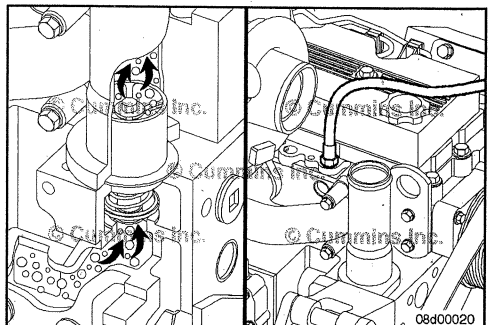

Section 8 - Maintenance Procedures at 5000 Hours or 4 Years

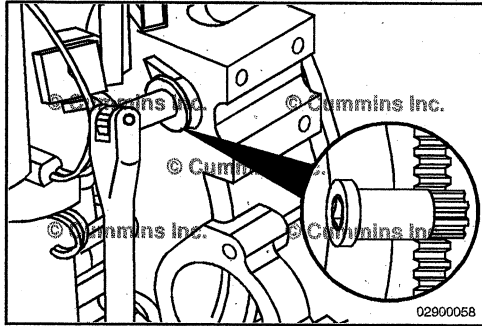

Using the engine barring tool, Part Number 3824591, rotate the crankshaft 360 degrees to align the mark on the fuel pump gear with the mark on the gear cover that is 180 degrees away from top dead center.

When the engine is in position, brake lash can be set on cylinders 2, 4, and 6.

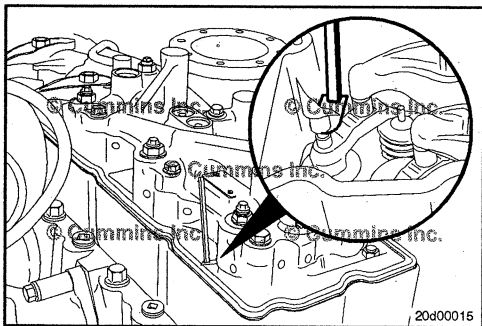

Insert the appropriate brake lash feeler gauge between the brake sleeve piston and the exhaust crosshead pin on cylinder number 2.

Brake Lash - Feeler Gauge	
Tool Part No.	Lash Specification
3163681	2.286 mm [0.090 in]

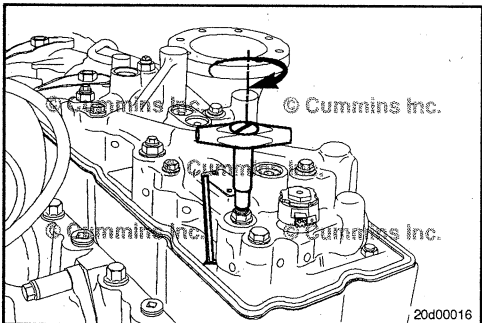

Using the 6 in-lb torque wrench, Part Number 3376592, tighten the adjusting nut until the torque wrench "clicks," or until drag is felt on the feeler gauge.

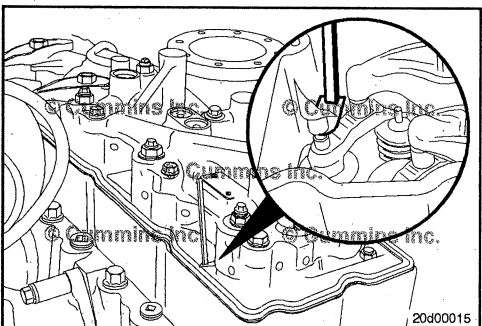

Remove the feeler gauge. Using two wrenches, hold the adjusting nut and tighten the locknut.

**Torque Value: 35 N•m [ 25 ft-lb ]**

Repeat for cylinders 4 and 6.

## Flow Diagram, Fuel System

### General Information

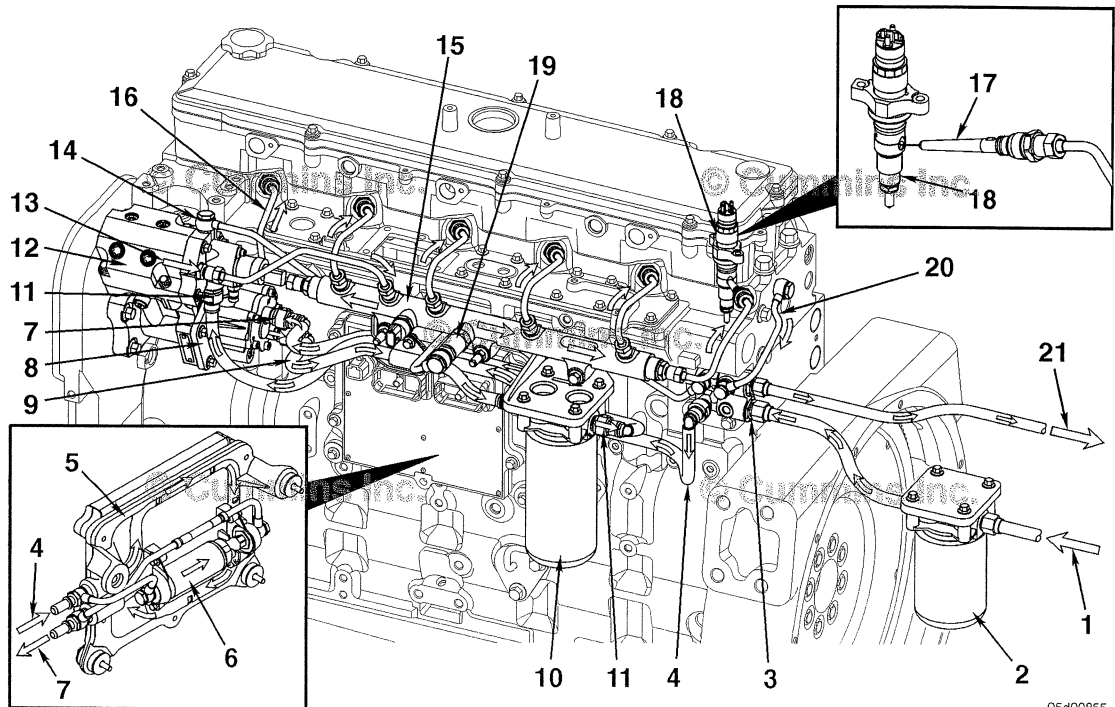

Cummins Common Rail Fuel System

05d00855

- |  |  |
|--|--|
| 1. Fuel from supply tank                       | 12. High-pressure fuel pump                  |
| 2. Fuel filter and water separator             | 13. Fuel outlet from high-pressure pump      |
| 3. OEM fuel supply connection                  | 14. High-pressure pump drain flow connection |
| 4. Fuel supply to ECM mounted fuel lift pump   | 15. Fuel rail                                |
| 5. ECM cooling plate                           | 16. High-pressure injector supply lines      |
| 6. ECM mounted fuel lift pump                  | 17. High-pressure fuel connector             |
| 7. Fuel outlet from ECM mounted fuel lift pump | 18. Fuel injector                            |
| 8. Fuel gear pump                              | 19. Fuel pressure relief valve               |
| 9. Fuel from gear pump to fuel filter          | 20. Fuel injector drain flow line            |
| 10. Primary fuel filter                        | 21. Fuel return to supply tanks              |
| 11. Fuel inlet to fuel pump actuator           |  |

### Flow Diagram, Exhaust System

#### General Information

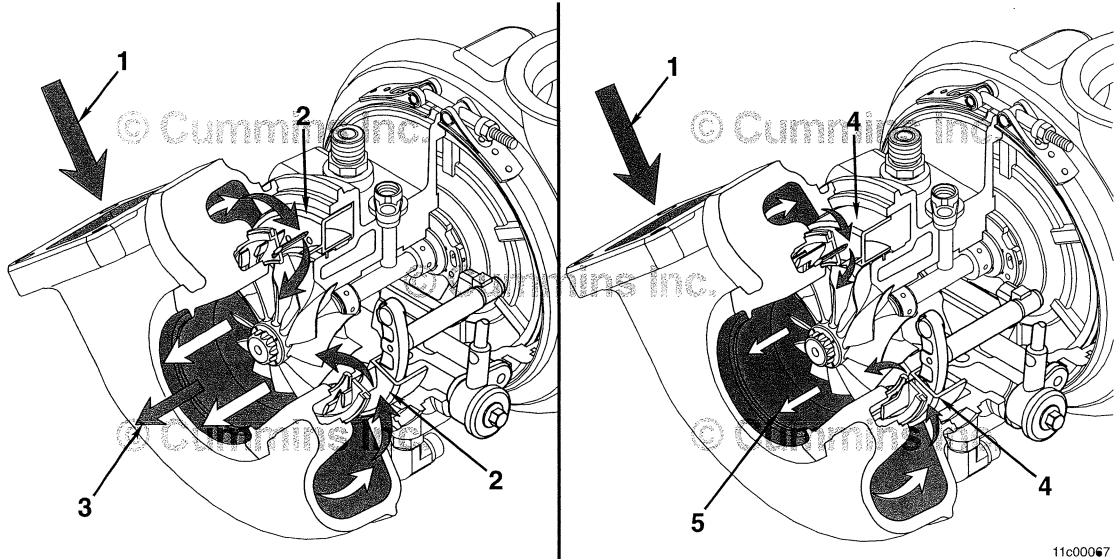

Variable Geometry Turbocharger

11c00067

## Cummins Customized Parts Catalog

### General Information

Cummins is pleased to announce the availability of a parts catalog compiled specifically for you. Unlike the generic versions of parts catalogs that support general high volume parts content; Cummins Customized catalogs contains only the new factory parts that were used to build your engine.

The catalog cover, as well as the content, is customized with you in mind. You can use it in your shop, at your worksite, or as a coffee table book in your RV or boat. The cover contains your name, company name, address, and telephone number. Your name and engine model identification even appears on the catalog spine. Everybody will know that Cummins created a catalog specifically for you.

This new catalog was designed to provide you with the exact information you need to order parts for your engine. This will be valuable for customers that do not have easy access to the Cummins Electronic Parts Catalog or the Cummins Parts Microfilm System.

Additional Features of the Customized Catalog include:

- Engine Configuration Data
- Table of Contents
- Separate Option and Parts Indexes
- Service Kits (when applicable)
- ReCon Part Numbers (when applicable)

### Ordering the Customized Parts Catalog

#### Ordering by Telephone

North American customers can contact their Cummins Distributor or call Gannett Direct Marketing Services at 1-800-646-5609 and order by credit card. Outside North America order on-line or make an International call to Gannett at (+ +)502-454-6660.

#### Ordering On-Line

The Customized Parts Catalog can be ordered On-Line from the Cummins Powerstore by credit card. Contact the Powerstore at [WWW.POWERSTORE.CUMMINS.COM](http://WWW.POWERSTORE.CUMMINS.COM)

Contact GDMS or the CUMMINS POWERSTORE for the current price; Freight may be an additional expense.

Information we need to take your Customized Parts Catalog Order. This information drives the cover content of the CPC.

- Customer Name
- Street Address
- Company Name (optional)
- Telephone no.
- Credit Card No.
- Cummins Engine Serial Number (located on the engine data plate)
- Please identify the required media: Printed Catalog, CD-ROM, or PDF File

Unfortunately not all Cummins Engines can be supported by this parts catalog. Engines older than 1984 or newer than 3 months may not have the necessary parts information to compile a catalog. We will contact you if this occurs and explain why we are unable to fill your order.

Customized Parts Catalogs are produced specifically for a single customer. This means they are not returnable for a refund. If we make an error and your catalog is not useable, we will correct that error by sending you a new catalog.

<b>North Carolina</b>	<b>Wilson Branch</b>	Cummins Atlantic, Inc. 1514 Cargill Avenue (27893) P.O. Box 1177 Wilson, NC 27894-1117 Telephone: (252) 237-9111 FAX: (252) 237-9132
<b>North Dakota</b>	<b>Fargo - (Branch of St. Paul)</b>	Cummins North Central, Inc. 3801 - 34th Ave. SW Fargo, ND 58104 Telephone: (701) 282-2466 FAX: (701) 277-5399
<b>North Dakota</b>	<b>Grand Forks - (Branch of St. Paul)</b>	Cummins North Central, Inc. 4728 Gateway Drive Grand Forks, ND 58201 Telephone: (701) 775-8197 FAX: (701) 775-4833
<b>North Dakota</b>	<b>Minot - (Branch of St. Paul)</b>	Cummins North Central, Inc. 1501 - 20th Avenue, S.E. Minot, ND 58702 Telephone: (701) 852-3585 FAX: (701) 852-3588
<b>Ohio</b>	<b>Columbus Distributor and Branch</b>	Cummins Interstate Power, Inc. 4000 Lyman Drive Hilliard (Columbus), OH 43026 Telephone: (614) 771-1000 FAX: (614) 771-0769
<b>Ohio</b>	<b>Columbus Distributor</b>	Cummins Interstate Power, Inc. 2297 Southwest Blvd., Suite K Grove City, OH 43123 Telephone: (614) 771-1000 FAX: (614) 527-2576
<b>Ohio</b>	<b>Cincinnati Branch</b>	Cummins Interstate Power, Inc. 10470 Evendale Drive Cincinnati, OH 45241 Telephone: (513) 563-6670 FAX: (513) 563-0594
<b>Ohio</b>	<b>Cleveland Branch</b>	Cummins Interstate Power, Inc. 7585 Northfield Road Cleveland, OH 44146 Telephone: (440) 439-6800 FAX: (440) 439-7390
<b>Ohio</b>	<b>Strasburg Branch</b>	Cummins Interstate Power, Inc. 777 South Wooster Avenue Strasburg, OH 44680 Telephone: (216) 878-5511 FAX: (216) 878-7666
<b>Ohio</b>	<b>Toledo Branch</b>	Cummins Interstate Power, Inc. 801 Illinois Avenue Maumee (Toledo), OH 43537 Telephone: (419) 893-8711 FAX: (419) 893-5362

<b>Bogota Regional Office - Columbia</b>									
Cummins Engine Co. de Colombia S.A. Carrera 11A No. 90-15 Of. 601/602 Bogota, D.E., Colombia Telephone: (57-1) 610-4849	Mailing Address: Apartado Aereo 90988 Bogota D.E., Colombia								
Countries Covered: <table style="width: 100%; border: none;"> <tr> <td style="width: 50%;">Argentina</td> <td style="width: 50%;">Ecuador</td> </tr> <tr> <td>Bolivia</td> <td>Paraguay</td> </tr> <tr> <td>Chile</td> <td>Peru</td> </tr> <tr> <td>Colombia</td> <td>Uruguay</td> </tr> </table>		Argentina	Ecuador	Bolivia	Paraguay	Chile	Peru	Colombia	Uruguay
Argentina	Ecuador								
Bolivia	Paraguay								
Chile	Peru								
Colombia	Uruguay								

<b>Gross-Gerau Regional Office - Germany</b>															
Cummins Diesel Deutschland GmbH Odenwaldstr. 23 D-4521 Gross-Gerau Germany Telephone: (49-6152) 174-0															
Countries Covered: <table style="width: 100%; border: none;"> <tr> <td style="width: 50%;">Albania</td> <td style="width: 50%;">Poland</td> </tr> <tr> <td>Bulgaria</td> <td>Romania</td> </tr> <tr> <td>Latvia</td> <td>Lithuania</td> </tr> <tr> <td>Germany</td> <td>Estonia</td> </tr> <tr> <td>Luxembourg</td> <td>Croatia</td> </tr> <tr> <td>Slovenia</td> <td>Bosnia</td> </tr> <tr> <td>Macedonia</td> <td></td> </tr> </table>		Albania	Poland	Bulgaria	Romania	Latvia	Lithuania	Germany	Estonia	Luxembourg	Croatia	Slovenia	Bosnia	Macedonia	
Albania	Poland														
Bulgaria	Romania														
Latvia	Lithuania														
Germany	Estonia														
Luxembourg	Croatia														
Slovenia	Bosnia														
Macedonia															

<b>Hong Kong Regional Office - Hong Kong</b>	
Cummins Engine H.K. Ltd. Unison Industrial Centre 15th Floor, Units C & D 27-31 Au Pui Wan Street P. O. Box 840 Shatin Fo Tan, Shatin, N.T. Hong Kong Telephone: (852) 2606-5678 Fax: (852) 2691-1641, 2687-3552	
Country Covered: Hong Kong, Macau	

<b>Pune Kirloskar Regional Office - India</b>							
Kirloskar Cummins Limited Kothrud Pune - 411 029, India Telephone: (91-212) 33-0240, 33-5435, 33-1105							
Countries Covered: <table style="width: 100%; border: none;"> <tr> <td style="width: 50%;">Bhutan</td> <td style="width: 50%;"></td> </tr> <tr> <td>India</td> <td></td> </tr> <tr> <td>Nepal</td> <td></td> </tr> </table>		Bhutan		India		Nepal	
Bhutan							
India							
Nepal							

### Engine Will Not Crank or Cranks Slowly (Air Starter)

Cause	Correction
<p><b>STEP 1</b> Air pressure is low in the air tanks</p>	<p>Increase air pressure with an external air source. Refer to the OEM service manual.</p>
<p>OK Go To Next Step</p>	
<p><b>STEP 2</b> Engine-driven units are engaged</p>	<p>Disengage engine-driven units.</p>
<p>OK Go To Next Step</p>	
<p><b>STEP 3</b> Lubricating oil level is above specification</p>	<p>Check the oil level. Verify the dipstick calibration and oil pan capacity. Fill the system to the specified level. Refer to Lubricating Oil Level is Above Specification symptom tree.</p>
<p>OK Go To Next Step</p>	
<p><b>STEP 4</b> Lubricating oil does <b>not</b> meet specifications for operating conditions</p>	<p>Change the oil and filters. Refer to Lubricating Oil Does Not Meet Specification symptom tree or Procedure 018-003.</p>
<p>OK Go To Next Step</p>	
<p><b>STEP 5</b> Starting motor is malfunctioning or starting motor is <b>not</b> correct</p>	<p>Check the starting motor operation. Compare the starting motor with the engine and vehicle specifications. Refer to the manufacturer's instructions.</p>
<p>OK Go To Next Step</p>	
<p><b>STEP 6</b> Contact a Cummins Authorized Repair Facility</p>	