

# Table of Contents

	Section
Introduction .....	i
Engine and System Identification .....	E
Operating Instructions .....	1
Daily Maintenance .....	2
Routine Maintenance .....	3
Adjustment, Repair, and Replacement .....	A
System Diagrams .....	D
Service Literature .....	L
Service Assistance .....	S
Engine Storage .....	ES
Troubleshooting Symptoms .....	TS
Maintenance Specifications .....	V
Warranty .....	W
Back .....	back

## Engine Identification

### Engine Dataplate

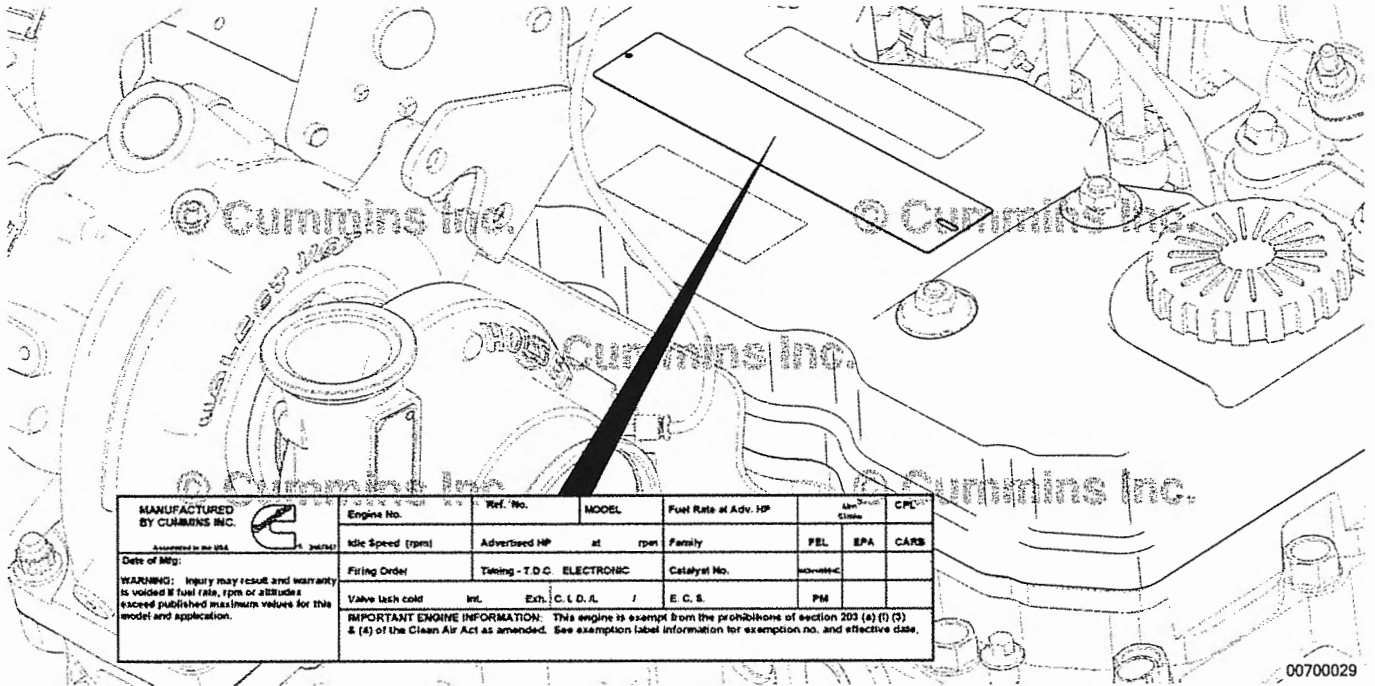

<b>MANUFACTURED BY CUMMINS INC.</b> <small>Assembled in the USA</small>	Engine No.	Ref. No.	MODEL	Fuel Rate at Adv. HP	FR	CPL
	Idle Speed (rpm)	Advertised HP at rpm	Family	FEL	EPA	CARB
<small>Date of Mfg:</small> WARNING: Injury may result and warranty is voided if fuel rate, rpm or altitudes exceed published maximum values for this model and application.	Firing Order	Timing - T.D.C.	ELECTRONIC	Catalyst No.	Valve lash cold	Int. Exh. C.I.D. / E.C.S.
IMPORTANT ENGINE INFORMATION: This engine is exempt from the prohibitions of section 203 (a) (5) & (4) of the Clean Air Act as amended. See exemption label information for exemption no. and effective date.						

00700029

The engine dataplate provides important information about the engine. The engine serial number (ESN) and control parts list (CPL) provide information for service and for ordering parts. The engine dataplate **must not** be changed unless approved by Cummins Inc.

Have the following engine data available when communicating with a Cummins® Authorized Repair Location. The information on the dataplate is mandatory when sourcing service parts.

<b>CUMMINS INC.</b> <small>Assembled in the USA</small> Date of Mfg XX-XX-XX	Engine No. XXXXXXXX	Ref. No. XXXXXXXXXX	Model XXXXXXXXXXXXX	Fuel Rate at Adv. HP/ka (mm3/sf) XXX	FR XXXXX	CPL XXXXX
	Idle Speed (rpm) XXXX	Advertised HP XXXXX at XXXX rpm	Family XXXXXXXXXXXXX	STD/FEL	EPA	CARB
WARNING: Injury may result and warranty is voided if fuel rate, rpm or altitudes exceed published maximum values for this model and application.	Firing Order XXXXXX	Timing - T.D.C.	ELECTRONIC	Category XXX - XXX	XXX	X.X
	Valve lash cold X:XXX" int.	Exh. C.I. D. /L XXX/XX.X	E. C. S. XXXXXXXXXXXX	PM	X.X	

00100001

- 1 Engine serial number
- 2 Engine model information
- 3 Valve lash (overhead) setting
- 4 Horsepower and rpm rating
- 5 Emission control system.

## Cummins® Product Technology

### General Information

The service model name for this product is **B4.5 CM2350 B146C**.

This engine is being released to meet the following emission regulations:

#### United States and Canada

- Environmental Protection Agency (EPA)
  - Tier 4 (Final)

#### European Union

- Stage V (Euro)

#### Korea (South)

- Tier 4 (Final)

The Control Parts List(s) (CPL) associated with this product are:

- 4936
- 4937
- 4938

#### EPA Products:

This engine has the following Agency defined Emissions Control System hardware, which can also be found on the engine dataplate. Use the following procedure for the location of the engine dataplate. Refer to Procedure 100-001 in Section E.

- Charge-Air Cooler (CAC)
- Direct Diesel Injection (DDI)
- Engine Control Module (ECM)
- Turbocharger (TC)
- Oxidation Catalyst (OC)
- Periodic Trap Oxidizer (PTOX)
- Selective Catalytic Reduction - Urea (SCR-U)
- Ammonia Oxidizer (AMOX)

This engine uses the following product technology:

#### Engine

- Number of Cylinders: 4
- Engine Configuration
  - Inline
- Engine Orientation
  - Vertical
- Cylinder Block Material
  - Cast Iron
- Cylinder Head Material
  - Cast Iron
- Valves Per Cylinder
  - Exhaust Quantity: 2
  - Intake Quantity: 2
- Camshaft Location
  - Cylinder Block

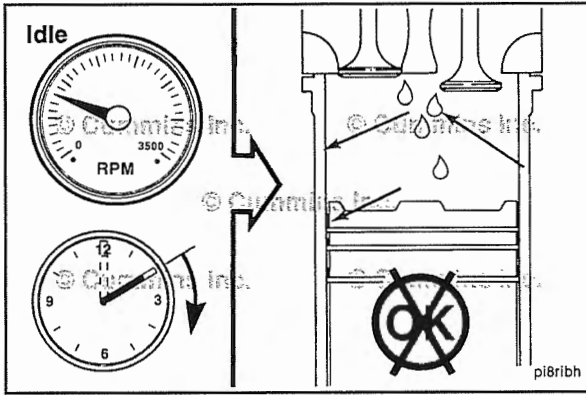

**⚠CAUTION⚠**

Do not idle the engine for excessively long periods. Long periods of idling, more than 10 minutes, can cause poor engine performance.

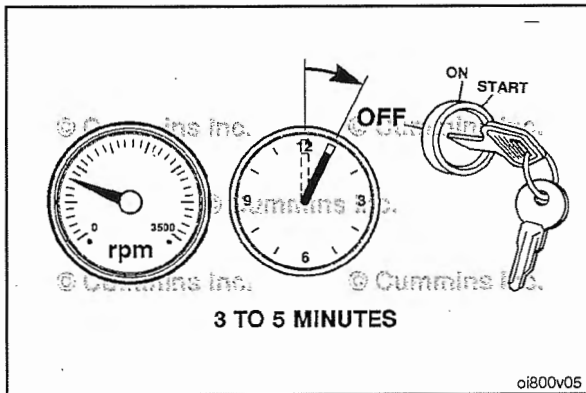

## Engine Shutdown

### General Information

**⚠CAUTION⚠**

Failure to follow the correct shutdown procedure may result in damage to the turbocharger, if equipped, and shorten the turbocharger life.

Allow the engine to idle 3 to 5 minutes before shutting the engine off after a full-load operation. This allows adequate cool down of pistons, cylinders, bearings, and turbocharger, if equipped.

**NOTE:** For engines equipped with an electronic control module (ECM) ensure the keyswitch is turned off for a minimum of 100 seconds prior to disconnecting the continuous (unswitched) battery power supply. If the unswitched battery power supply is disconnected in less than 100 seconds after the keyswitch is turned off active fault codes and incorrect ECM information can occur.

Turn the ignition switch to the OFF position. If the engine does **not** shut down, contact a Cummins® authorized repair location.

## Electronic Controlled Fuel System

### General Information

The base functions of the control system include fueling and timing control, limiting the engine speed operating range between the low- and the high-idle set points, and optimizing engine performance while maintaining emissions compliance. The system also controls the engine brakes.

The control system uses inputs from the operator and its sensors to determine the fueling and timing required to operate at the desired engine speed and at the required emissions level.

# Cummins Service Publications Electronic Book on DVD-ROM Information

The enclosed DVD-ROM provides you with the capability to view this publication electronically as well as perform searches. This DVD-ROM is copy protected and will not allow Printing, Changing of Content, Extracting Content or Commenting / Annotating of the PDF file.

This DVD-ROM is read only, and you will not be able to copy files from the DVD-ROM and have them open or function in any manner. The only method to view the electronic publication is from the original DVD-ROM.

This DVD-ROM is intended for use by the owner of the publication only. Copying or distribution of content from this DVD-ROM is expressly prohibited. This DVD-ROM will not function from a network server DVD-ROM drive. It will function only in a DVD-ROM drive directly connected to your computer.

**This DVD-ROM requires that you have Local Administrative rights in order to use. See the System requirements section for additional details.**

## System Requirements:

Use of the Cummins Service Publications Electronic Book on DVD-ROM requires Adobe Acrobat Reader, or Adobe Acrobat software to be installed on your computer. This product has been tested for compatibility with Adobe Acrobat Reader software. It may function properly with earlier or later versions of Adobe Acrobat DC, but testing has not been performed. Adobe Acrobat Reader is available as a free download from [www.adobe.com](http://www.adobe.com).

## The Cummins Service Publications Electronic Book on DVD-ROM product requires the following system components:

- Microsoft Windows Auto-Play must be enabled on your computer (it is enabled by default when Windows is installed)
- DVD-ROM Drive
- Color Monitor with at least 1024x768 resolution graphics
- Microsoft Windows 7, Microsoft Windows 8, or Microsoft Windows 10. Use on other Microsoft Operating Systems may be compatible but testing has not been performed, and while it may function, it is not supported. While we try to maintain compatibility with all popular Microsoft Operating Systems, compatibility with the listed Microsoft Operating Systems is subject to change.
- Recommended memory, processor speed and available hard-disk space is in accordance with respective Microsoft Operating System Guidelines, as well as Adobe Acrobat system requirements.

Note: The Cummins Service Publications Electronic Book on DVD-ROM product is not Macintosh compatible.

## About required Local Administrative Rights:

The copy protection software requires direct access to the DVD-ROM on which the protected content is stored. Protected content is only accessible to users with restricted accounts if allowed each time the disk is used.

In order to allow the software to enable direct access to DVD-ROM drives under Microsoft Windows, without user intervention, your logon account/profile must have Local Administrative Rights. If the computer is set up in Restricted Mode, or your logon account/profile does not have Local Administrative Rights, then, with approval of your I.T. department or the owner of your computer, you can choose from the following options to allow the Cummins Service Publications Electronic Book on DVD-ROM to function properly:

- Have your computer account enabled to have Local Administrative rights and then you can run the Cummins Service Publications Electronic Book on DVD-ROM - OR -
- Have a user with Local Administrative Rights logon to your computer run the DVD-ROM content one time, and then restart this computer. By doing this, the necessary files will be installed, and your computer will be enabled to have direct access to DVD-ROM drives. It is necessary to restart the computer after this has been done. For all future needs, you can run the Cummins Service Publications Electronic Book on DVD-ROM under your own account, without requiring your logon account/profile to have Local Administrative Rights. (Note: This needs to be done only once for any Cummins Service Publications Electronic Book on DVD-ROM and then does not need to be done again for other Cummins Service Publications Electronic Book on DVD-ROM titles you may own that are of the same version of protection software.)





**NOTE:** A newly installed belt and/or tensioner will **not** come to rest properly until the engine is operated. Always operate the engine for a brief period of time prior to verifying the tensioner resting location.

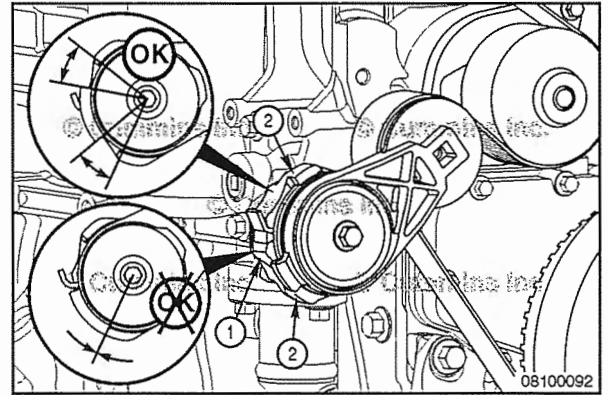

Inspect the automatic belt tensioner. Refer to Procedure 008-087 in Section 3. If the belt tensioner does **not** meet the reuse criteria, the belt tensioner **must** be replaced.

With the belt installed, check the automatic belt tensioner resting position. If the belt tensioner arm stop is contacting either of the spring case stops:

- Verify the correct belt part number is installed.
- If the correct belt is installed, replace the belt.

Verify all accessory drive components and pulleys are correct. Components yielding incorrect part numbers, or installed without the appropriate spacers and/or brackets can contribute to gross drive belt misalignment.

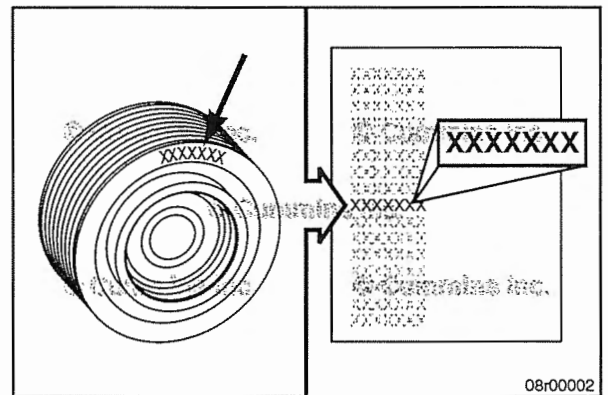

Verify proper drive belt routing, if available. See equipment manufacturer service information.

Isolating the source of drive belt noise can be done by use of an electronic stethoscope, or an equivalent device designed to block audible noise other than that desired by use of a microphone.

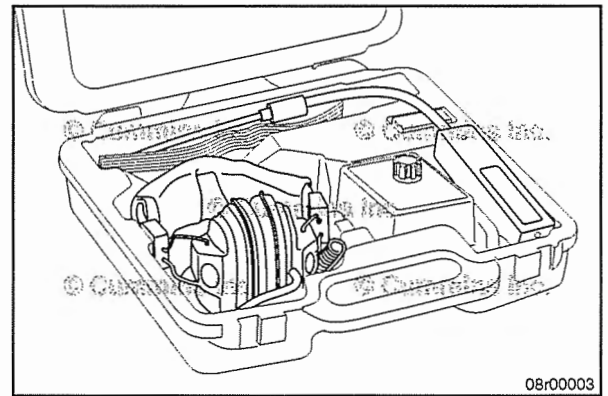

Drive belt noise can be difficult to isolate and troubleshoot. The origin of drive belt noise may **not** be located at the pulley out of alignment, rather 'upstream' from the noise origin.



Troubleshooting should always be completed in a direction opposite belt travel (i.e. counter clockwise) beginning at the pulley where the noise originates.

Arrow number (1) indicates belt travel direction, whereas arrow number (2) represents the direction in which troubleshooting should be conducted.

- Flat pulleys should be inspected for uneven wear patterns.
- Grooved pulleys should be inspected for embedded debris, belt dust buildup, and pulley alignment.

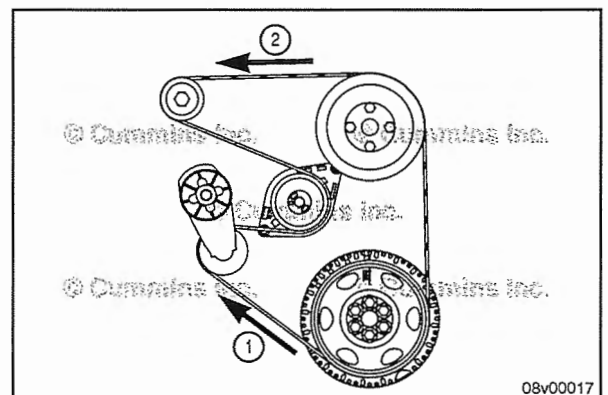

**⚠ CAUTION ⚠**

Soap, solvent, or water ingress into air intake system can cause engine damage.

Do not directly spray or allow soap, solvent, or water to enter any passages, ports, or cowlings that lead to the engine air intake system.

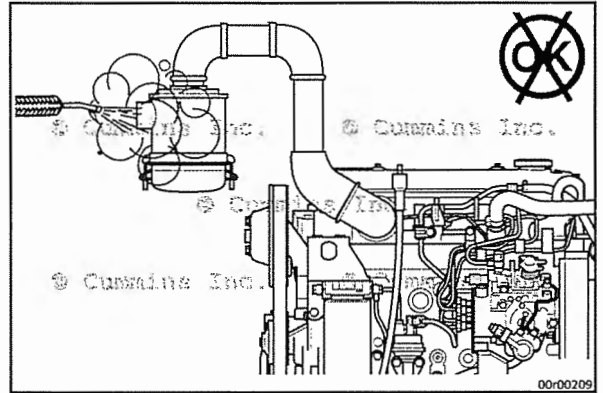

**Radiator Hoses  
Maintenance Check**

Check all hoses for cracks, cuts, or collapsing.

**NOTE:** The silicone engine coolant hose will exhibit swelling due to the elasticity of the hose.

If damage is found, replace damaged hoses. Contact your local Cummins Authorized Repair Location.

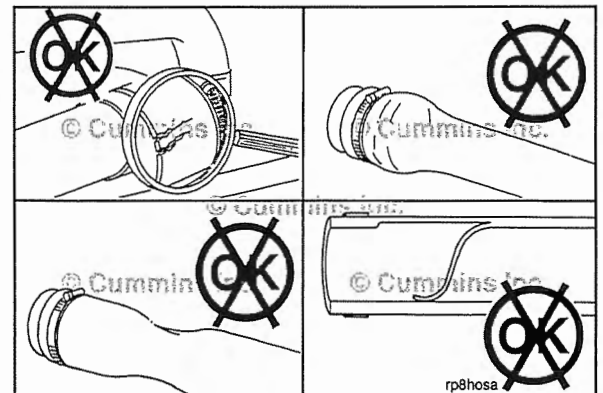

**Air Compressor Discharge Lines  
General Information**

All air compressors have a small amount of lubricating oil carryover that lubricates the piston rings and moving parts. When this lubricating oil is exposed to normal air compressor operating temperatures over time, the lubricating oil will form varnish or carbon deposits. If the following maintenance check are not performed, the air compressor piston rings will wear and not seal correctly.

**Maintenance Check**

**⚠ WARNING ⚠**

Wear appropriate eye and face protection when using compressed air. Flying debris and dirt can cause personal injury.

Shut off the engine.

Open the drain valve on the wet tank to release the system air pressure.

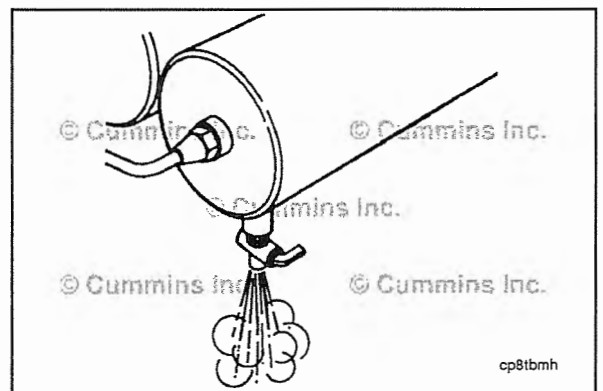

## Adjustment, Repair and Replacement - Overview

### General Information

This section contains supplemental procedures to support maintenance and repair practices.

These procedures provide additional instructions necessary to complete select maintenance tasks. Procedures for basic repair practices are also included in this section. If additional instructions are needed, contact your local Cummins® Authorized Repair Location for assistance.

## Engine Barring

### Select Service Tools

#### Recommended Cummins® Service Tools

- Barring tool, Part Number 5299073, or equivalent

#### Additional Service Items

- No additional service items required.

### General Information

#### ⚠ WARNING ⚠

Do not pull or pry on the fan to manually rotate the engine. To do so can damage the fan blades. Damaged fan blades can cause premature fan failures which can result in serious personal injury or property damage.

This procedure instructs how to rotate the engine for service events.

**NOTE:** The illustrations in this procedure are generic and may **not** represent the hardware on all engines.

### Preparatory Steps

#### ⚠ WARNING ⚠

Batteries can emit explosive gases. To reduce the possibility of personal injury, always ventilate the compartment before servicing the batteries. To reduce the possibility of arcing, remove the negative (-) battery cable first and attach the negative (-) battery cable last.

- Disconnect the batteries. See equipment manufacturer service information.

### Rotate

#### ⚠ WARNING ⚠

When servicing the engine, do not use a remote starter switch or other means that would engage the starting motor to rotate the engine on a high-pressure common rail engine. Using the starter motor can create highly pressurized fuel in the fuel system. High-pressure fuel spray can penetrate the skin, resulting in serious personal injury or death. Use a hand barring tool to rotate the engine for servicing the engine. Always loosen the pump-to-rail fuel line at the rail to vent the pressure after rotating the engine. Keep hands clear of the line when loosening and wear appropriate eye protection.

Remove the access cover from the flywheel housing.

Rotate the engine by hand. Use barring tool, Part Number 5299073, or equivalent.

Rotate the engine **clockwise** when viewed from the front of the engine.

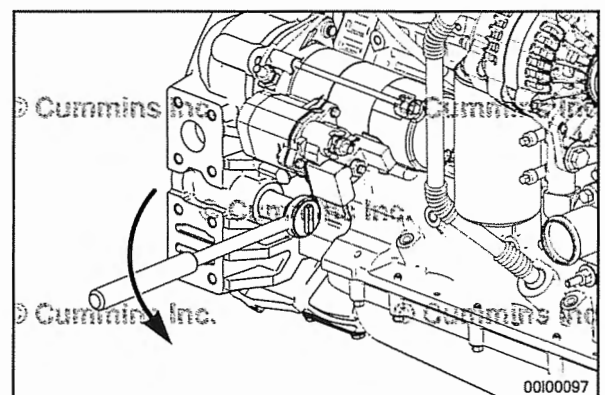

### Flow Diagram, Compressed Air System

#### Flow Diagram

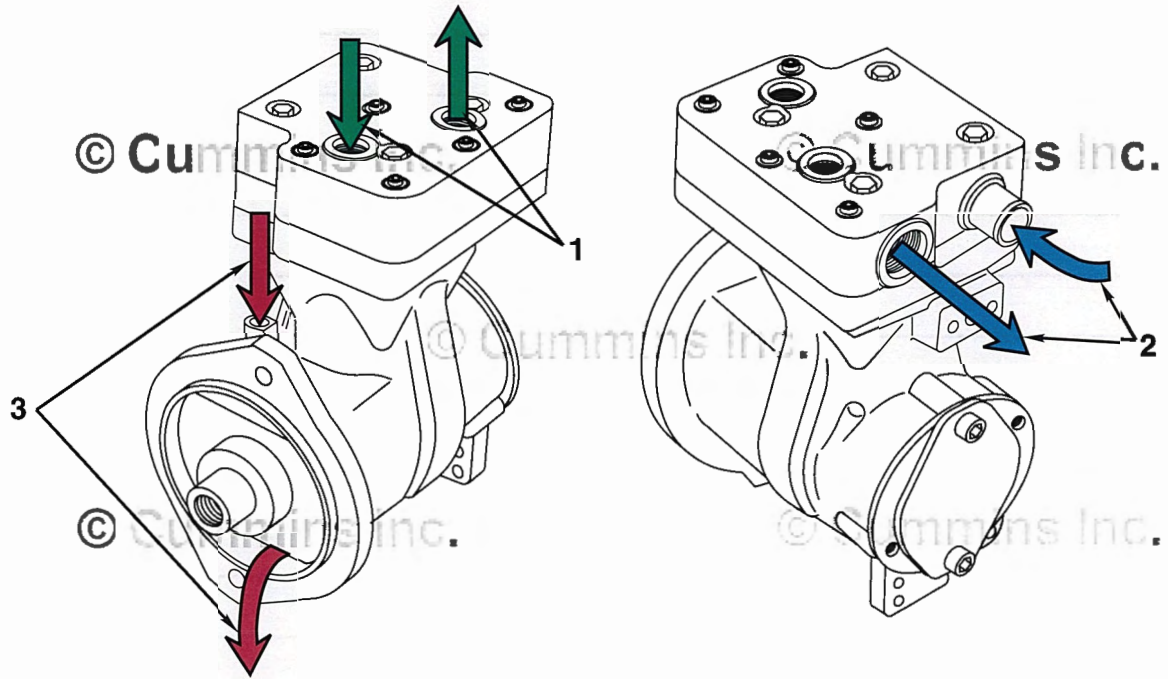

12d00033

- 1 Coolant
- 2 Air
- 3 Lubricant.

## Cummins Customized Parts Catalog

### General Information

Cummins is pleased to announce the availability of a parts catalog compiled specifically for you. Unlike the generic versions of parts catalogs that support general high volume parts content; Cummins Customized catalogs contain only the new factory parts that were used to build your engine.

The catalog cover, as well as the content, is customized with you in mind. You can use it in your shop, at your worksite, or as a coffee table book in your RV or boat. The cover contains your name, company name, address, and telephone number.

This new catalog was designed to provide you with the exact information you need to order parts for your engine. This will be valuable for customers that do not have easy access to Cummins QuickServe Online.

Additional Features of the Customized Catalog include:

- Engine Configuration Data
- Table of Contents
- Separate Option and Parts Indexes
- Service Kits (when applicable)
- ReCon Part Numbers (when applicable)

### Ordering the Customized Parts Catalog

#### Ordering by Telephone

- North American Distributors, Original Equipment Manufacturers and Cummins Factory personnel order by calling Iron Mountain Fulfillment Services (IMFS) at 1-800-646-5609.
- International Distributors and Original Equipment Manufacturers order the CPC from their regional Cummins Parts Distribution Centers (PDC).
- International PDC orders are called into Iron Mountain at (++) 630-283-2420.
- Retail Credit Card Orders require a 2 step ordering process.

#### Ordering On-Line

Access the Cummins QSOL store at <https://store.cummins.com>

- Find the Customized Parts Catalog button located on the left of the homepage
- Select format. Your Price is also shown here
- Finalize Shopping Cart and Check Process as described on the website

North America call Iron Mountain Fulfillment Services (IMFS) at 800-646-5609, International customers call (++) 630-283-2420. Provide IMFS the catalog detail as described on the website. This step is required until we have our On Line form available.

Required information needed for your Customized Parts Catalog Order.

- Customer Name
- Street Address
- Company Name (optional)
- Telephone no.
- Credit Card No.
- Cummins Engine Serial Number (located on the engine data plate)

Unfortunately not all Cummins Engines can be supported by Customized Parts Catalogs. Engines older than 1984 or newer than 3 months may not have the necessary parts information to compile a catalog. We will contact you if this occurs and explain why we are unable to fill your order.

Customized Parts Catalogs are produced specifically for a single customer. This means they are not returnable for a refund. If we make an error and your catalog is not useable, we will correct that error by sending you a new catalog.

### Coolant Temperature Above Normal - Sudden Overheat

#### Cause

#### Correction

<p><b>STEP 1</b> Engine indicator lamps illuminated</p> <p>OK Go To Next Step</p>	<p>Refer to Procedure 101-048 in Section 1.</p>
<p><b>STEP 2</b> Coolant level is below specification</p> <p>OK Go To Next Step</p>	<p>Check the coolant level. Check for an external leak. Refer to Procedure 008-066 in Section 2. Sample the lubricating oil and have a laboratory check for coolant in the oil (internal leak).</p>
<p><b>STEP 3</b> Fan drive belt is broken</p> <p>OK Go To Next Step</p>	<p>Check the fan drive belt. Replace the belt, if necessary. Refer to Procedure 008-002 in Section 3.</p>
<p><b>STEP 4</b> Cold weather radiator cover or winterfront is closed</p> <p>OK Go To Next Step</p>	<p>Open the cold weather radiator cover or the winterfront. Maintain a minimum of 387 cm<sup>2</sup> [60 in<sup>2</sup>] of opening at all times. Refer to Procedure 101-015 in Section 1.</p>
<p><b>STEP 5</b> Charge air cooler fins, radiator fins, or air conditioner condenser fins are damaged or obstructed with debris</p> <p>OK Go To Next Step</p>	<p>Inspect the charge air cooler, air conditioner condenser, and radiator fins. Clean, if necessary. Refer to Procedure 010-027 in Section 3.</p>
<p><b>STEP 6</b> Coolant temperature gauge is malfunctioning</p> <p>OK Go To Next Step</p>	<p>Test the temperature gauge. Repair or replace the gauge, if necessary. Contact a Cummins® Authorized Repair Location.</p>
<p><b>STEP 7</b> Cooling system hose is collapsed, restricted, or leaking</p> <p>OK Go To Next Step</p>	<p>Inspect the hoses. Refer to Procedure 008-045 in Section 3.</p>
<p><b>STEP 8</b> Radiator cap is <b>not</b> correct, is malfunctioning, or has low pressure rating</p> <p>OK Go To Next Step</p>	<p>Check the radiator pressure cap. Refer to equipment manufacturer service information.</p>
<p><b>STEP 9</b> Contact a Cummins® Authorized Repair Facility</p>	

### Engine Speed Surges Under Load or in Operating Range

Cause

Correction

STEP 31  
Internal engine damage

.....

Analyze the oil and inspect the filters to locate an area of probable damage. Contact a Cummins® Authorized Repair Location.

OK  
Go To Next Step

STEP 32  
Contact a Cummins® Authorized Repair Facility

### Lubricating Oil Consumption Excessive

#### Cause

#### Correction

<p><b>STEP 1</b> Crankcase ventilation system is plugged</p> <p>OK Go To Next Step</p>	<p>Check and clean the crankcase breather and vent tube. Refer to Procedure 003-018 in Section 2.</p>
<p><b>STEP 2</b> Lubricating oil does <b>not</b> meet specifications for operating conditions</p> <p>OK Go To Next Step</p>	<p>Change the oil and filter(s). Refer to Procedure 018-003 in Section V.</p>
<p><b>STEP 3</b> Lubricating oil drain interval is excessive</p> <p>OK Go To Next Step</p>	<p>Verify the correct lubricating oil drain interval. Refer to Procedure 358-001 in Section 2.</p>
<p><b>STEP 4</b> Lubricating oil leak (external)</p> <p>OK Go To Next Step</p>	<p>Inspect the engine for external oil leaks. Tighten the capscrews, pipe plugs, and fittings. Replace gaskets, if necessary.</p>
<p><b>STEP 5</b> Verify the oil consumption rate</p> <p>OK Go To Next Step</p>	<p>Check the amount of oil added versus the hours of operation.</p>
<p><b>STEP 6</b> Air compressor is pumping lubricating oil into the air system and turbocharger leaking oil internally</p> <p>OK Go To Next Step</p>	<p>Check the air lines for carbon buildup and lubricating oil. Remove the turbocharger inlet and exhaust tubing and check for oil deposits. Refer to a Cummins® Authorized Repair Location.</p>
<p><b>STEP 7</b> Contact a Cummins® Authorized Repair Facility</p>	