

CONTENTS

Communication BUS architecture	page 3
--------------------------------------	--------

Wiring diagrams	page 7
-----------------------	--------

Equipment locations	page 131
---------------------------	----------

Electrical distribution	page 219
-------------------------------	----------

Chassis-cab/bulkhead grommet connection	page 247
-----------------------------------------------	----------

Trailer connectors	page 253
--------------------------	----------

Available power supplies	page 257
--------------------------------	----------

Connectors	page 267
------------------	----------

CAN bus architecture

Key to devices

Code	Title of the function	Location
A303	On-board management pre-arrangement (ECU)	B2c
B026	Automatic transmission gear selector	B2b
C077	Nitrogen oxide concentration sensor	C4d
D001	Main information display	C2b
D004	Tachograph	C2b
G001	Vehicle management control unit	B2b
G002	Engine management ECU	B3b
G003	Body builder pre-equipment management control unit	B2b
G004	Air suspension control unit	B2b
G005	EBS management control unit	B2b
G007	Braking assistance modulator assembly (on front axle)	B3d
G008	Braking assistance modulator assembly on drive axle	B7d
G012	Lighting and signalling management control unit	B2c
G018	On-board management interface control unit	B2b
G019	Gear selector control unit	A2c
G020	Automatic transmission ECU	B2b
G022	Electric retarder control unit	A2b
G025	Engine immobiliser ECU	C2c
G026	Alarm ECU	A2a
G030	AdBlue supply management pump module	C4d
G051	Air production management ECU	C4d
G100	DATAMAX GATEWAY ECU	B2c
G102	Onboard management control unit	B2c
H014	Radio set	C2a
X200	Available power supplies connector	B2c
X906	ABS/EBS trailer socket	B4b
X913	Vehicle diagnostic socket	C4c
X914	Vehicle data extraction socket	C4c

AD : with automatic gearbox

BQ : with **FMS** equipment

CF : with **ALLISON** automatic gearbox

CG : with **ALLISON 3000V** automatic gearbox

CO : with **OPTIFLEET** equipment

DE : with **DATAMAX** equipment

YM : for vehicles manufactured after **2016/12/04**

YN : for vehicles manufactured before **2016/12/05**

V106	No. 6 cylinder injector solenoid valve	C02
V107	Air horn	H02
V114	Transfer box high speed control solenoid valve	C60
V115	Torque converter clutch solenoid valve	D02/D03
V116	Main module solenoid valve	D02/D03
V117	Pressure regulation solenoid valve No.1	D02/D03
V118	Pressure regulation solenoid valve No.2	D02/D03
V119	Pressure regulation solenoid valve No. 3	D02
V120	Pressure regulation solenoid valve No. 4	D02
V121	Pressure regulation solenoid valve No. 5	D02
V123	Speed change solenoid valve No.1	D02/D03
V124	Speed change solenoid valve No.2	D02/D03
V125	Speed change solenoid valve No.3	D03
V141	Urea cooling solenoid valve	C30
W100	Alternator circuit draw resistor	A01/A20/A40
W500	Diode(s)	A40/A42/A43/A44/B02/G01/ G20/H02/H03/J20
W502	Diode on after-ignition information circuit for vehicle management unit	A40/B02
W503	Diode on information relay power supply circuit (engine running)	A01/A20/A40/B20
W504	Diode on alternator earthing relay power supply circuit	A40
W505	Diode on alternator earthing relay power supply circuit	A40
W506	Diode for door central locking	A01/A40/G01/G20
W507	Vehicle alarm signalling diode	G20
X001	Electrical connection terminal	A01/A20
X200	Available power supplies connector	J01/J20/J21
X203	CAN bus grouping connector	K21
X207	Auxiliary audio connector	I20
X208	USB audio connector	I20
X900	15-pin trailer socket	J40
X902	24 volt power supply socket	I03
X906	ABS/EBS trailer socket	J40
X907	Ground power receptacle	A01/A20
X908	12 volt power supply socket	I03/I20
X909	Supplementary power supply socket 24 volts	I03
X913	Vehicle diagnostic socket	K01/K20/K23
X915	Automatic gearbox diagnostic socket	D01/D02/D03
Z005	Automatic gearbox assembly	D02/D03
Z008	Left-hand swivelling heated door mirror	I02
Z009	Right-hand swivelling heated door mirror	I02
Z010	Front passenger door locking striker unit	G01
Z011	Driver's door locking striker unit	G01

Vehicle electronic management (2/2)

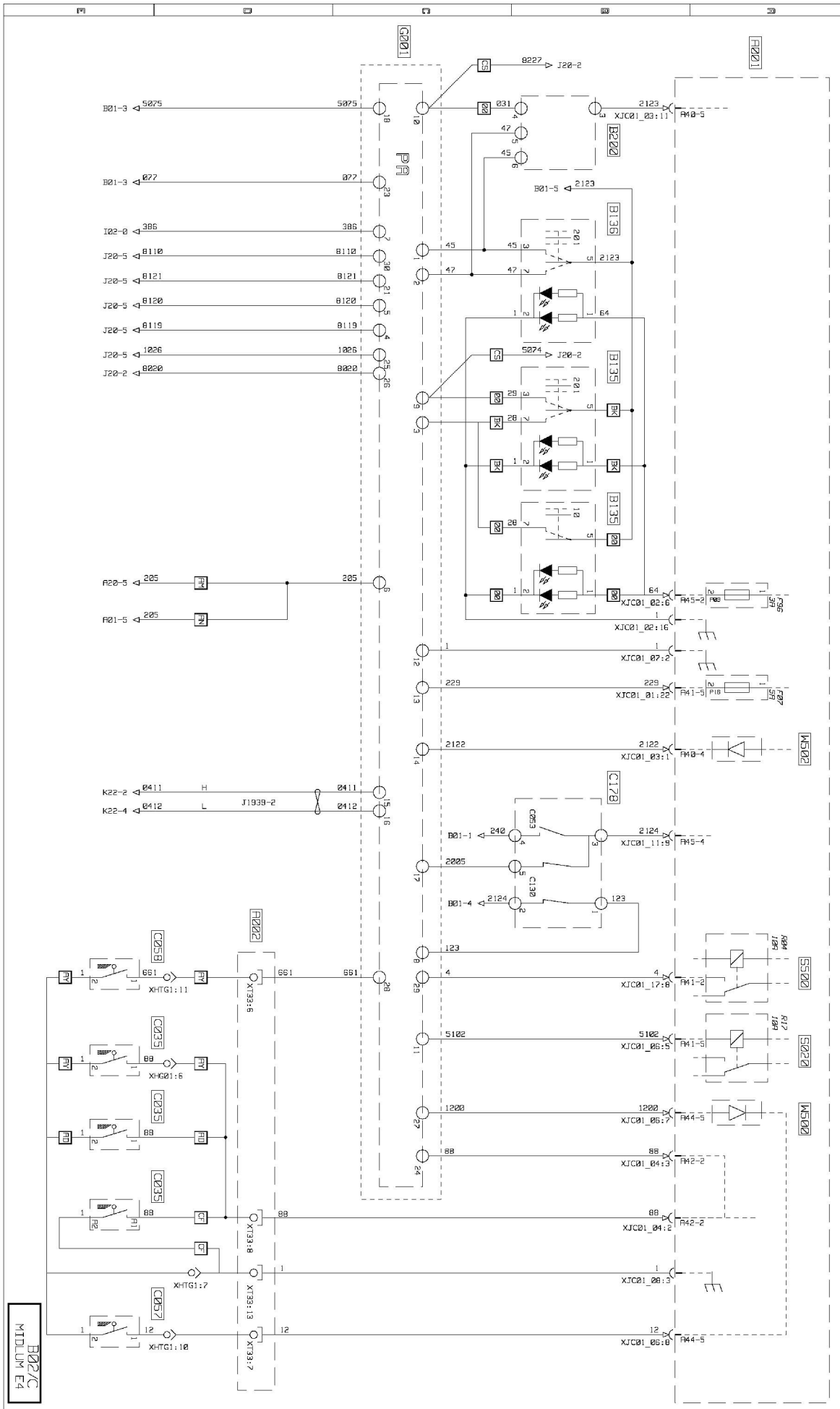

Engine electronic management (2/2)

Key to devices

Code	Title of the function	Location
B105	Engine stop control	B3c
C019	Boost air pressure and temperature sensor	B3c
C020	Boost air temperature sensor	B3c
C021	Boost air pressure sensor	B3c
C022	Engine oil level sensor	B3c
C024	Engine oil level and pressure sensor unit	B3c
C067	Engine speed sensor on engine flywheel	B2c
C068	Engine speed sensor on camshaft	B3c
C084	Engine oil temperature sensor	B3c
C096	Range change selector pressure sensor	B4d
C148	Fuel high pressure sensor	B3c
G002	Engine management ECU	B3d
V060	High-pressure pump solenoid valve	B3c
V101	No. 1 cylinder injector solenoid valve	B3c
V102	No. 2 cylinder injector solenoid valve	B3c
V103	No. 3 cylinder injector solenoid valve	B3c
V104	No. 4 cylinder injector solenoid valve	B3c
V105	No. 5 cylinder injector solenoid valve	B3c
V106	No. 6 cylinder injector solenoid valve	B3c

BE : with 7 l engine

BF : with 5 l engine

4x2 rear electronic air suspension (<18 t)

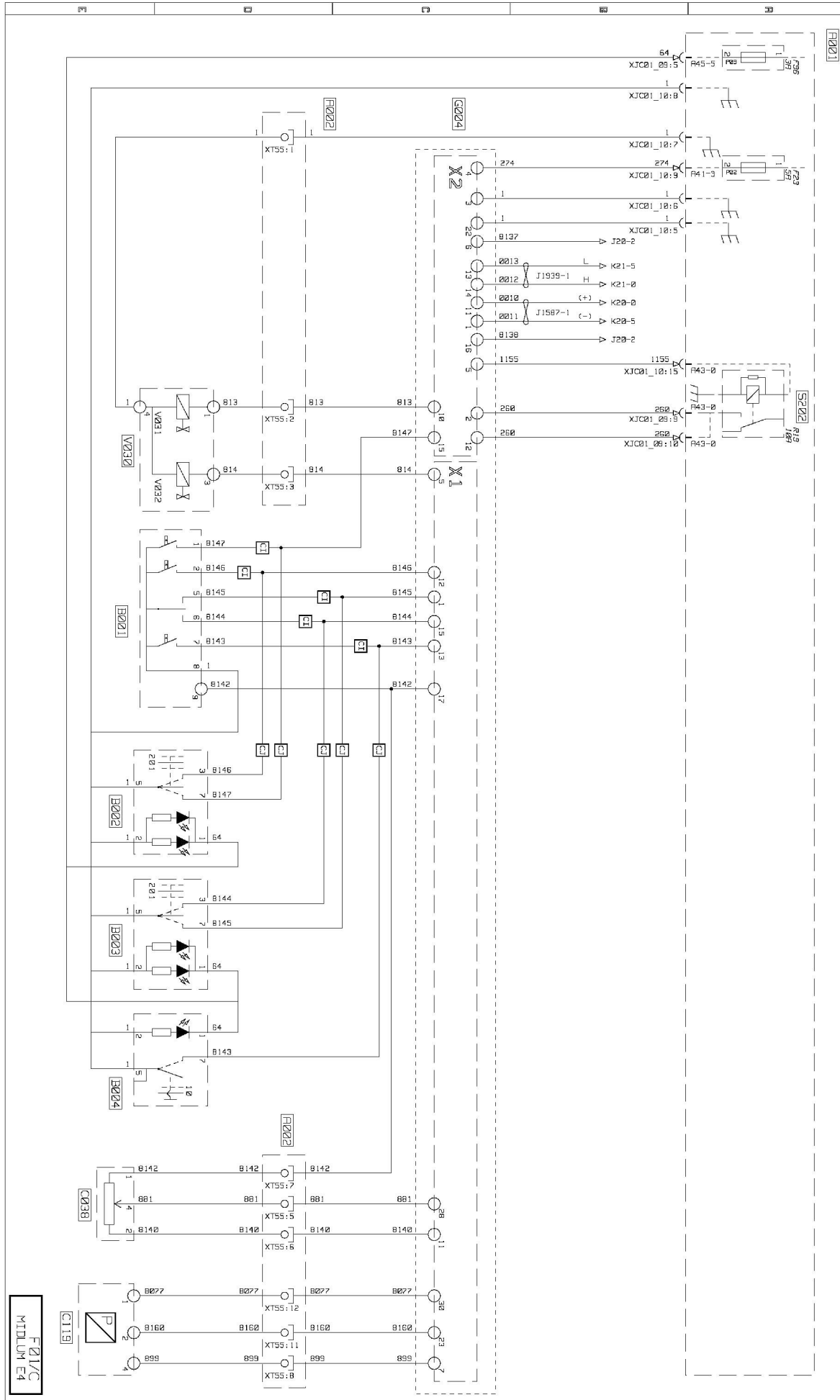

Radio

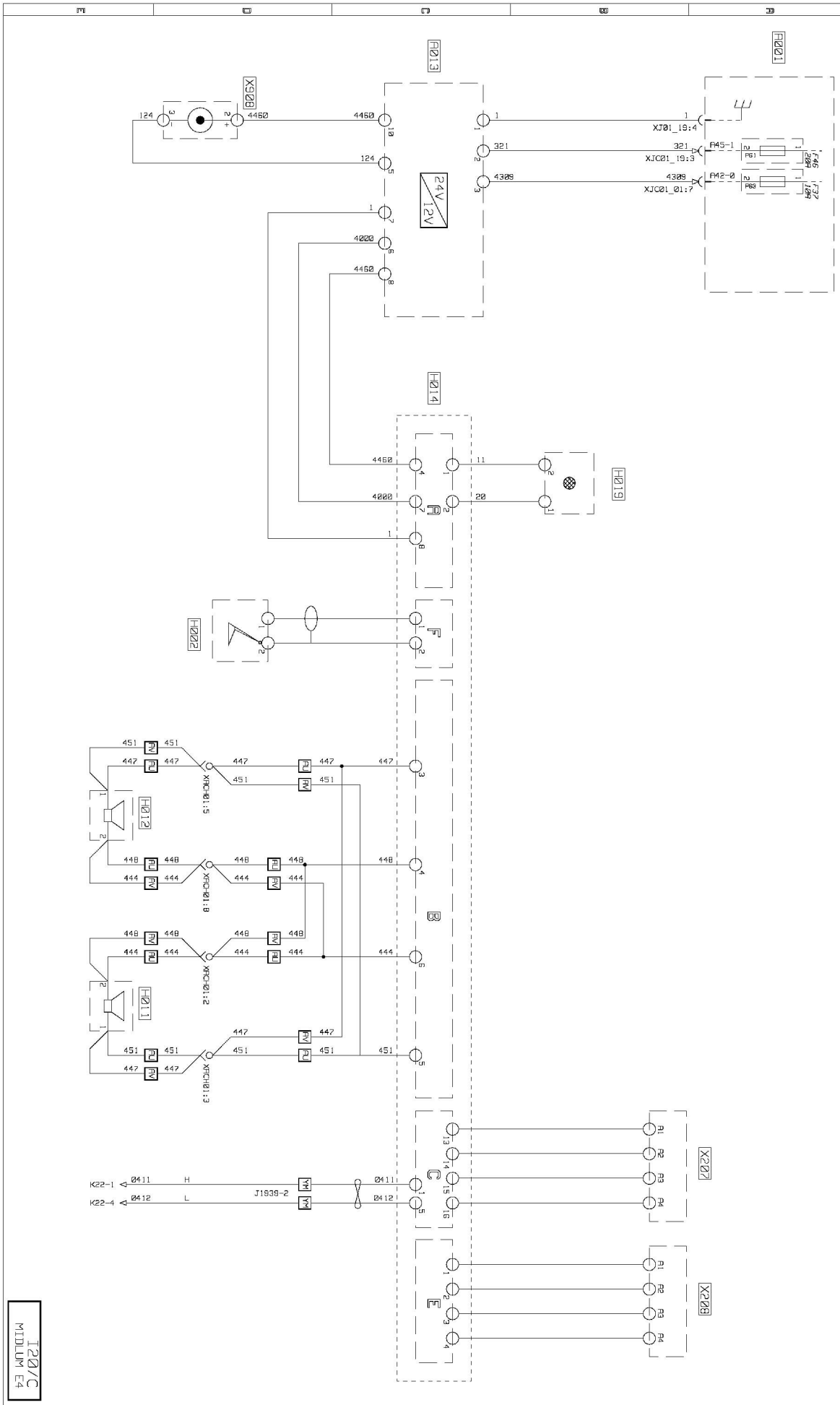

J1939-1 CAN bus transfer zone

Equipment key

Code	Title of the function	Location
A002	Chassis-cab connection box	B2c
B026	Automatic transmission gear selector	B2b
D001	Main information display	C2b
G001	Vehicle management control unit	B2b
G002	Engine management ECU	B2b
G003	Body builder pre-equipment management control unit	B2b
G004	Air suspension control unit	B2b
G005	EBS management control unit	B2b
G018	On-board management interface control unit	B2b
G019	Gear selector control unit	B3c
G020	Automatic transmission ECU	B2b
G022	Electric retarder control unit	B3c/B4d
G051	Air production management ECU	C4d
X203	CAN bus grouping connector	A2c

AD : with automatic gearbox

CG : with **ALLISON 3000V** automatic gearbox

CH : with **ALLISON S2000** automatic gearbox

CL : with rear electronic air suspension, **1** sensor (vehicle weight less than **18 t**)

CM : with full electronic air suspension (vehicle weight less than **18 t**)

CN : with rear electronic air suspension and full air suspension (vehicle weight less than **18 t**)

Managing the urea supply (2/2)

Equipment key

Code	Title of the function	Diagram page No.
C263	Internal urea temperature sensor	C30
C264	Internal urea pressure sensor	C30
G030	Urea supply management pump module	C30
V141	Urea cooling solenoid valve	C30
Z021	Urea pump module assembly	C30

DXi 7 engine electronic management (2/2)

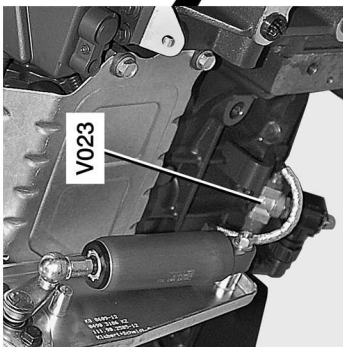
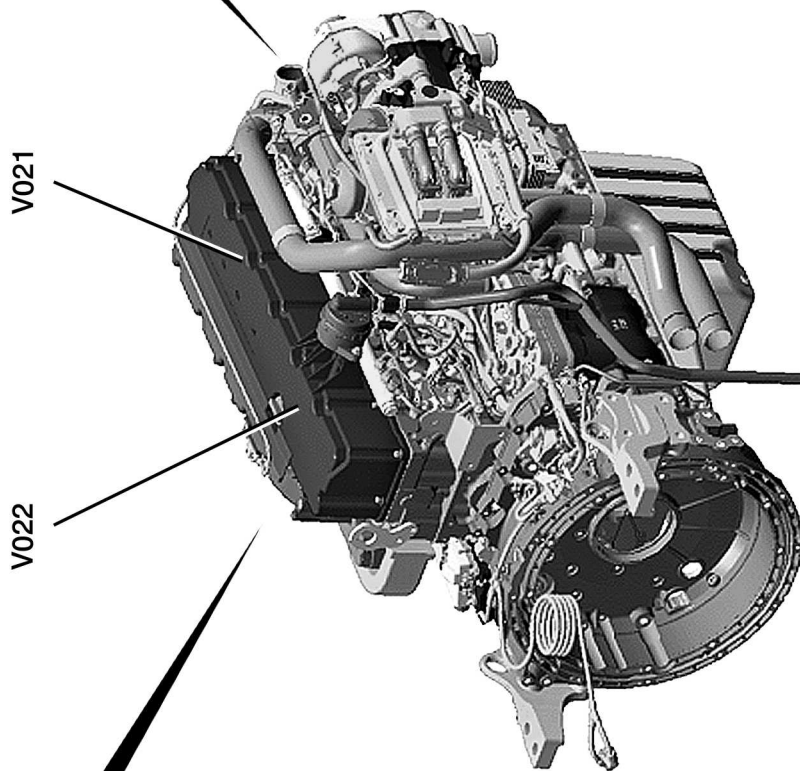
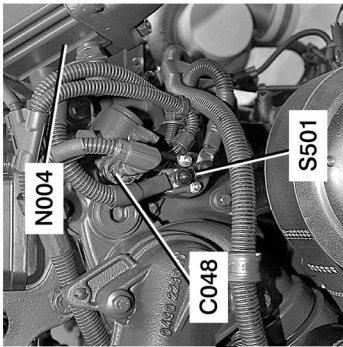

T3117890

EBS equipment

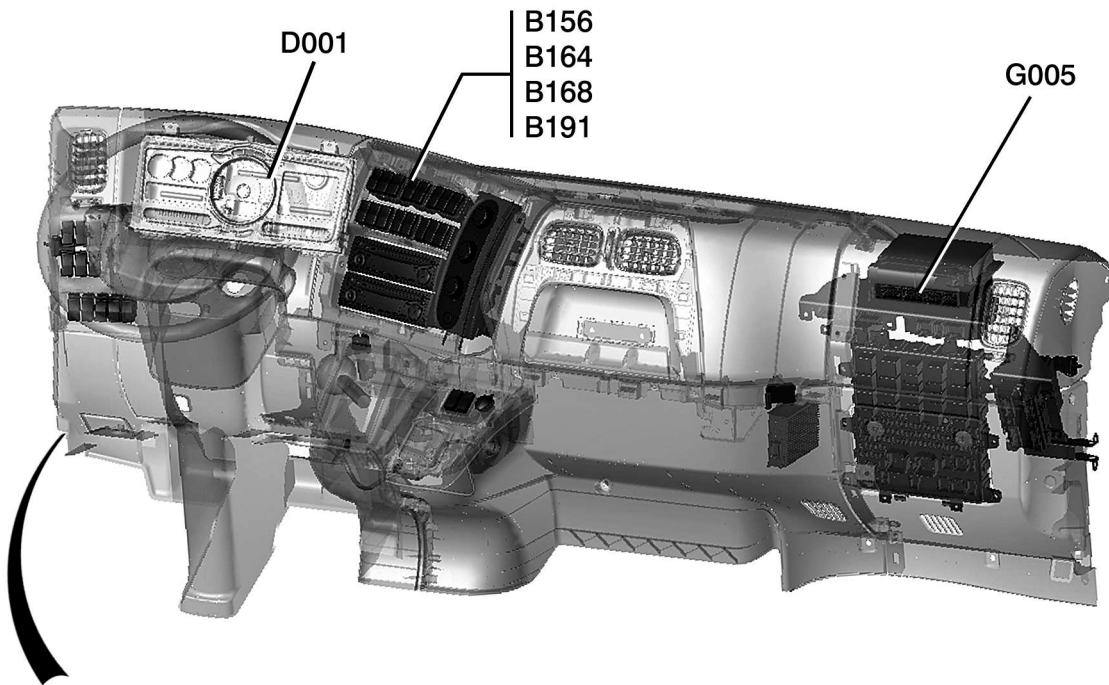
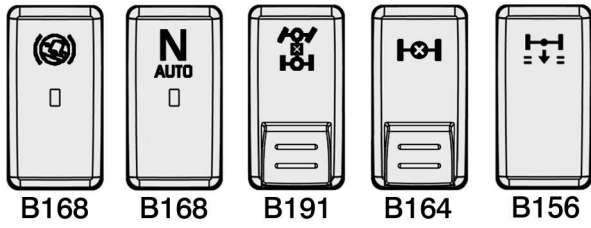

T3117898

S2000/3000V gearbox

Equipment key

Code	Title of the function	Diagram page No.
G020	Automatic gearbox ECU	D02

6AS800/6AS1000 gearbox (4/4)

Equipment key

Code	Title of the function	Diagram page No.
C062	Clutch position sensor	D01
C226	Automated manual transmission hydraulic circuit level sensor	D01
G020	Automatic gearbox ECU	D01
M104	Gearbox electric pump	D01

TTU/TGW control units

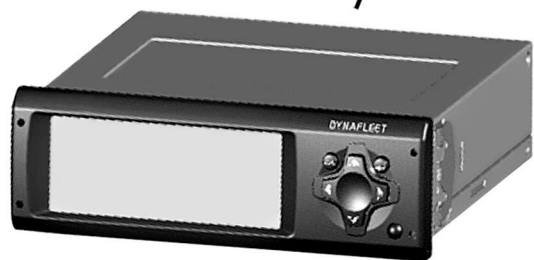

G018

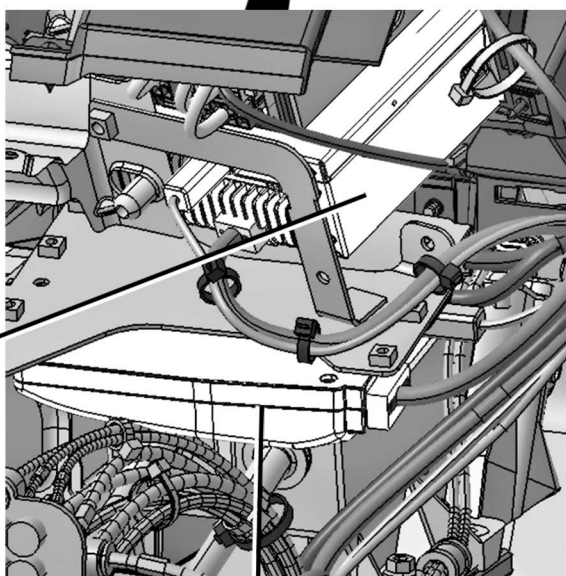

G102

T3117914

Table of fuses on electrical distribution box

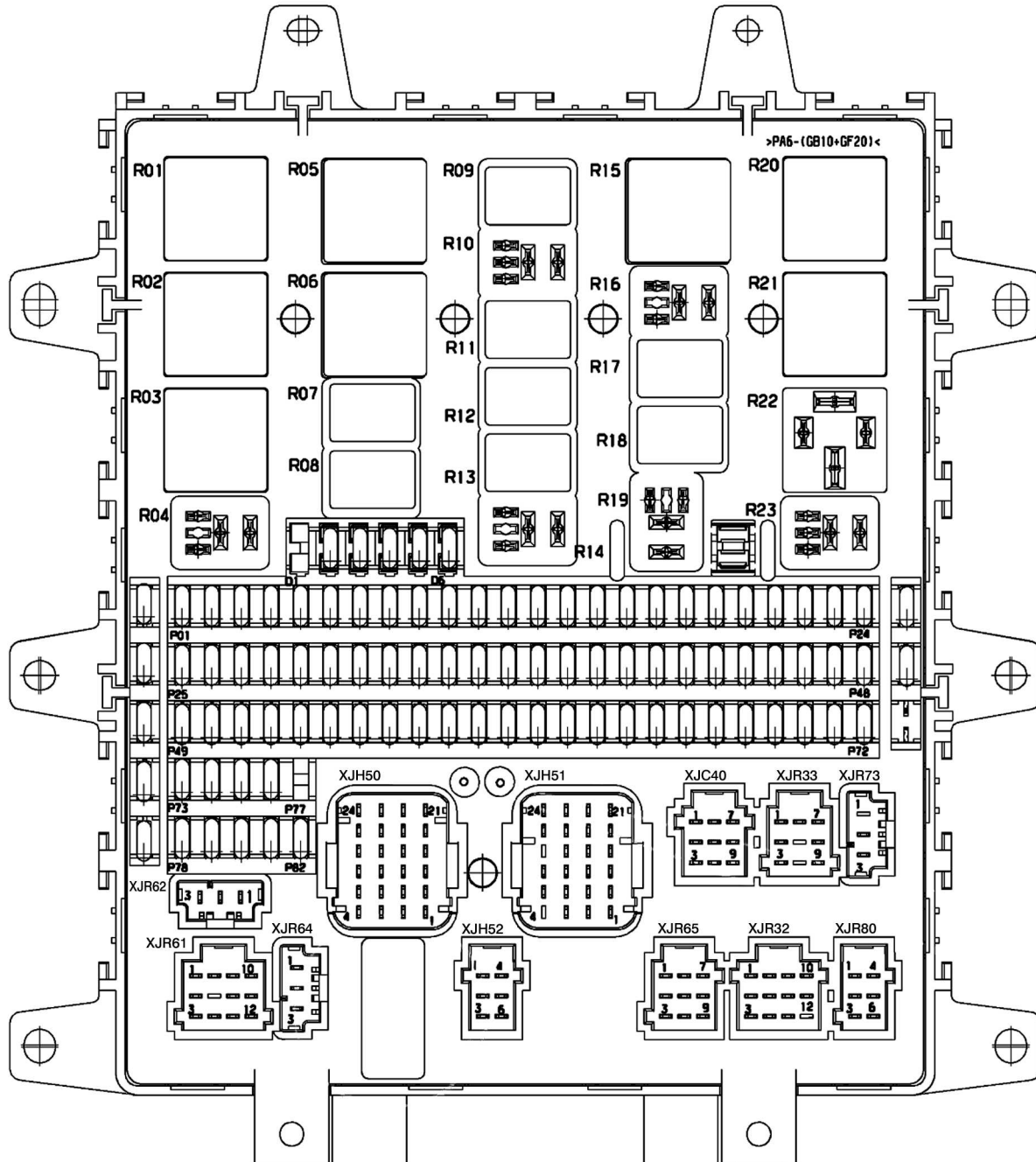

T3102081