

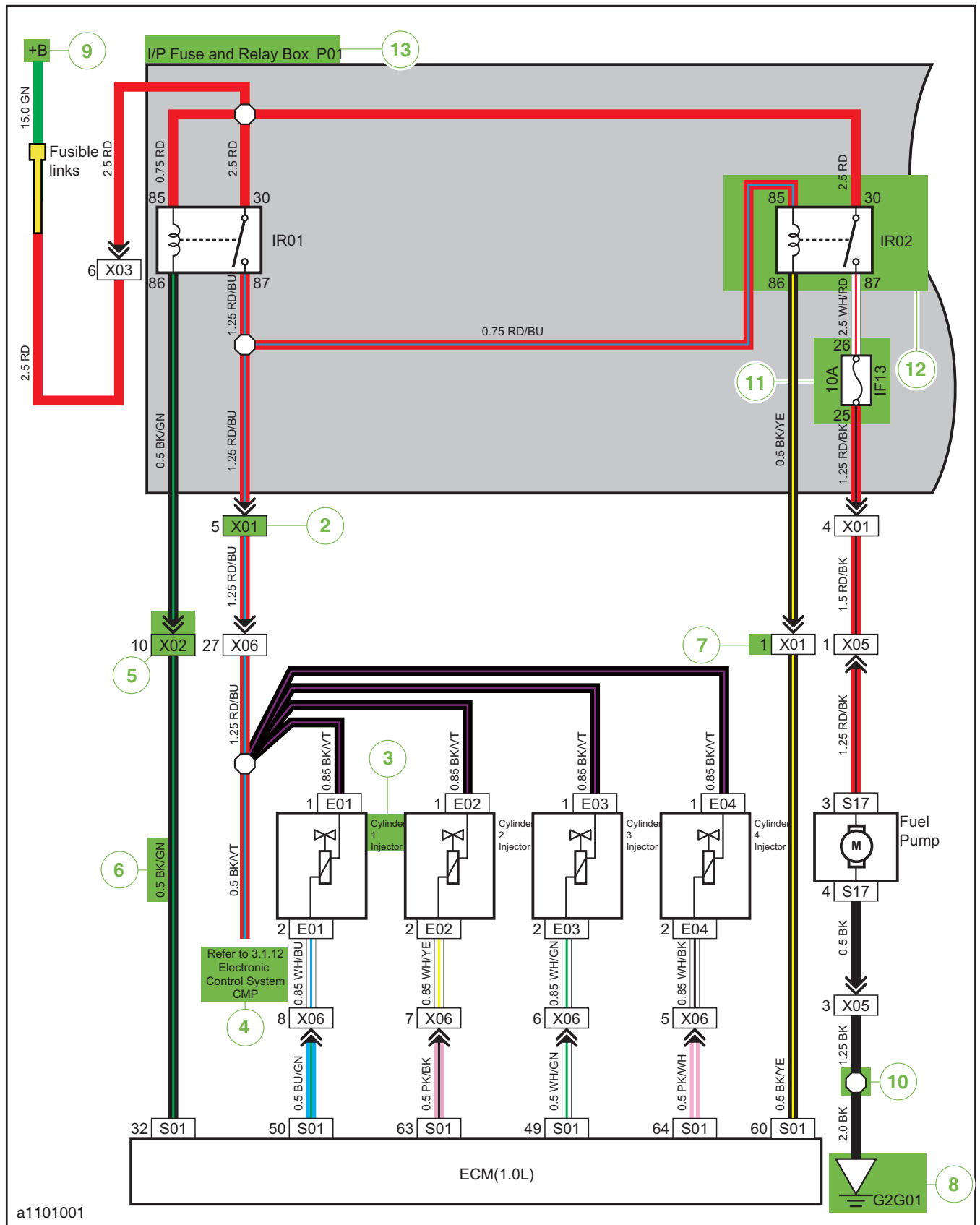

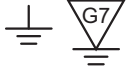

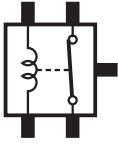





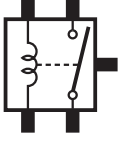

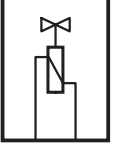
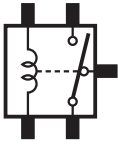
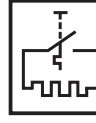



Fuel System

1

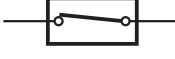

a1101001

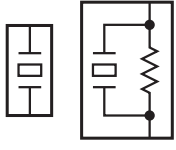
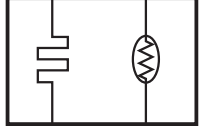
	Ground		Relay-Normally Closed		Battery
	Temperature Sensor		Relay-Normally Open		Capacitor
	Solenoid		Double Throw Relay		Cigarette Lighter
	Solenoid		Resistor		Antenna
	Light Load Fuse		Potentiometer		Switch-Normally Open
	Moderate Load Fuse		Rheostat		Switch-Normally Closed
	Heavy Load Fuse		Ignition Coil		Double Throw Switch
	Heater		Knock Sensor		Oxygen Sensor

C1102001

Cooling System (1.0L)

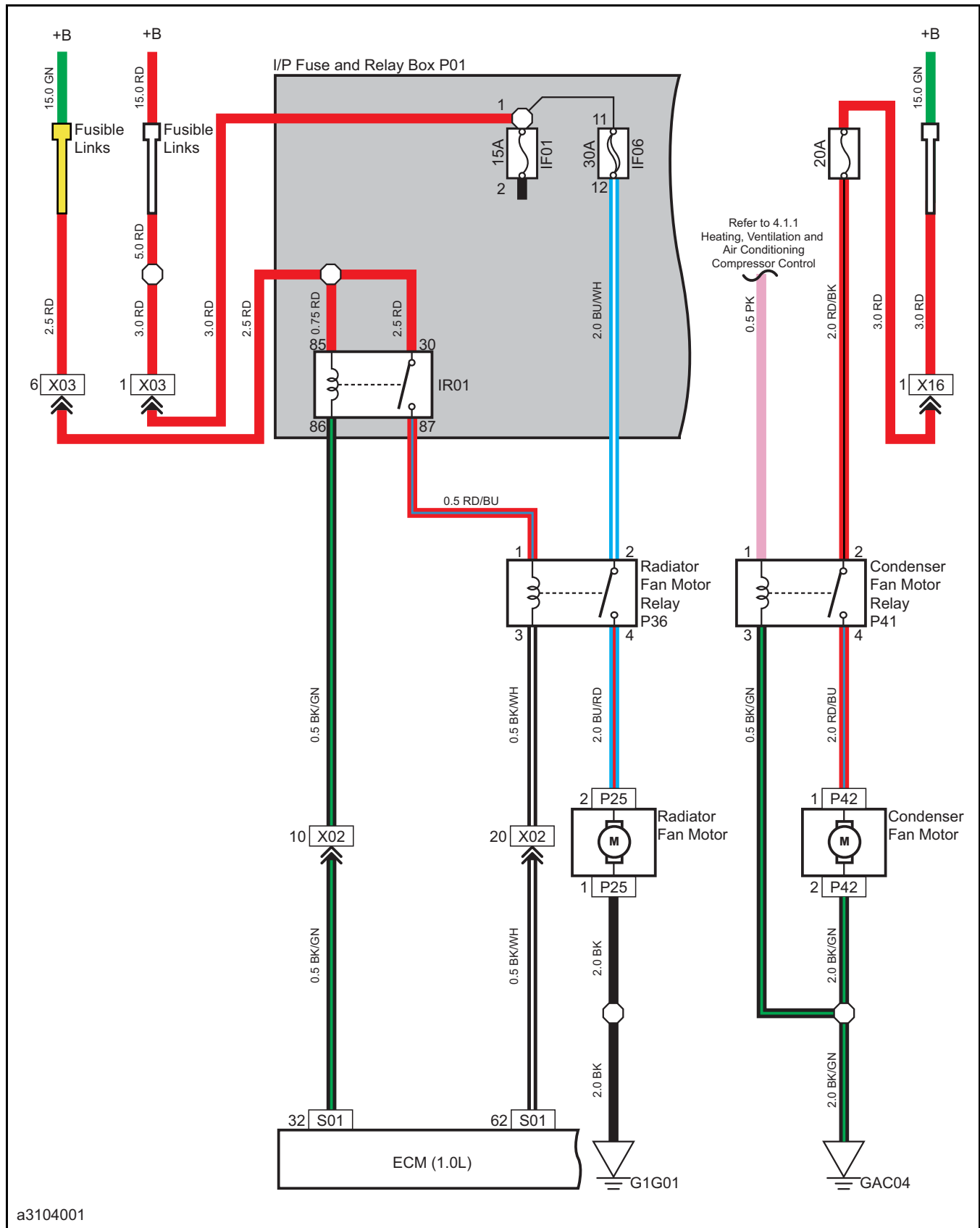

ECM Connector (1.3L)

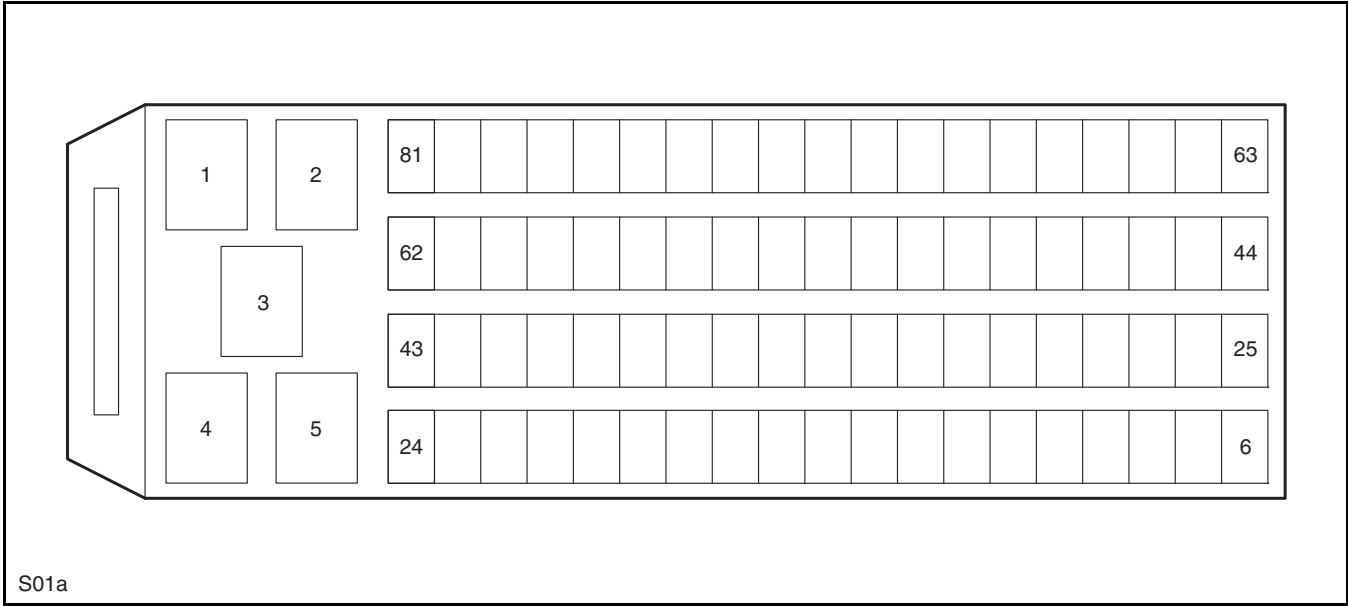

I/P Harness to Floor Harness Connector F

Floor Harness to I/P Harness Connector F

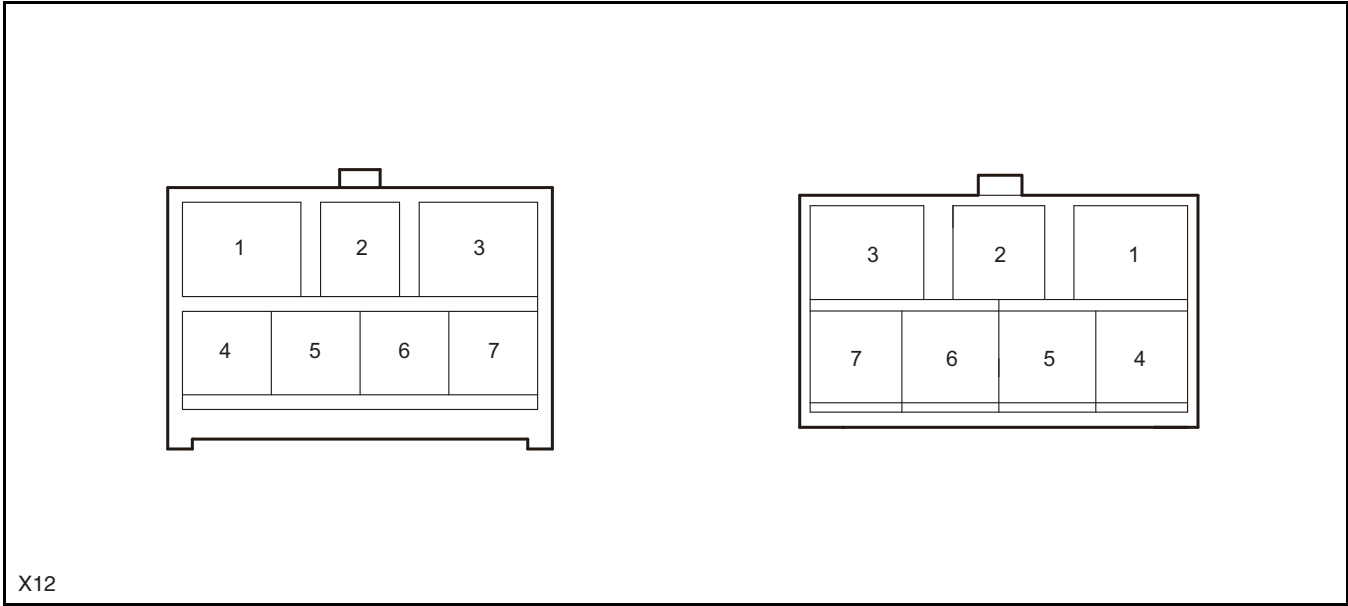

X12

CKP Sensor Connector

Cylinder (1,4) Connector

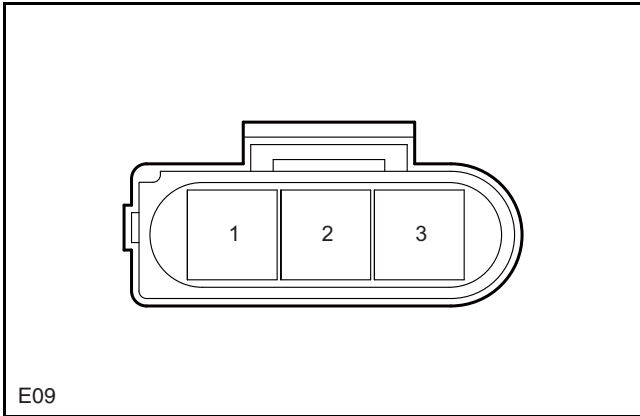

E09

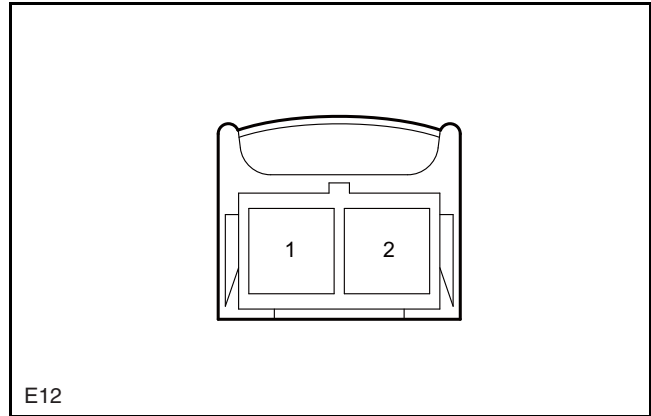

E12

Power Supply and Data Bus

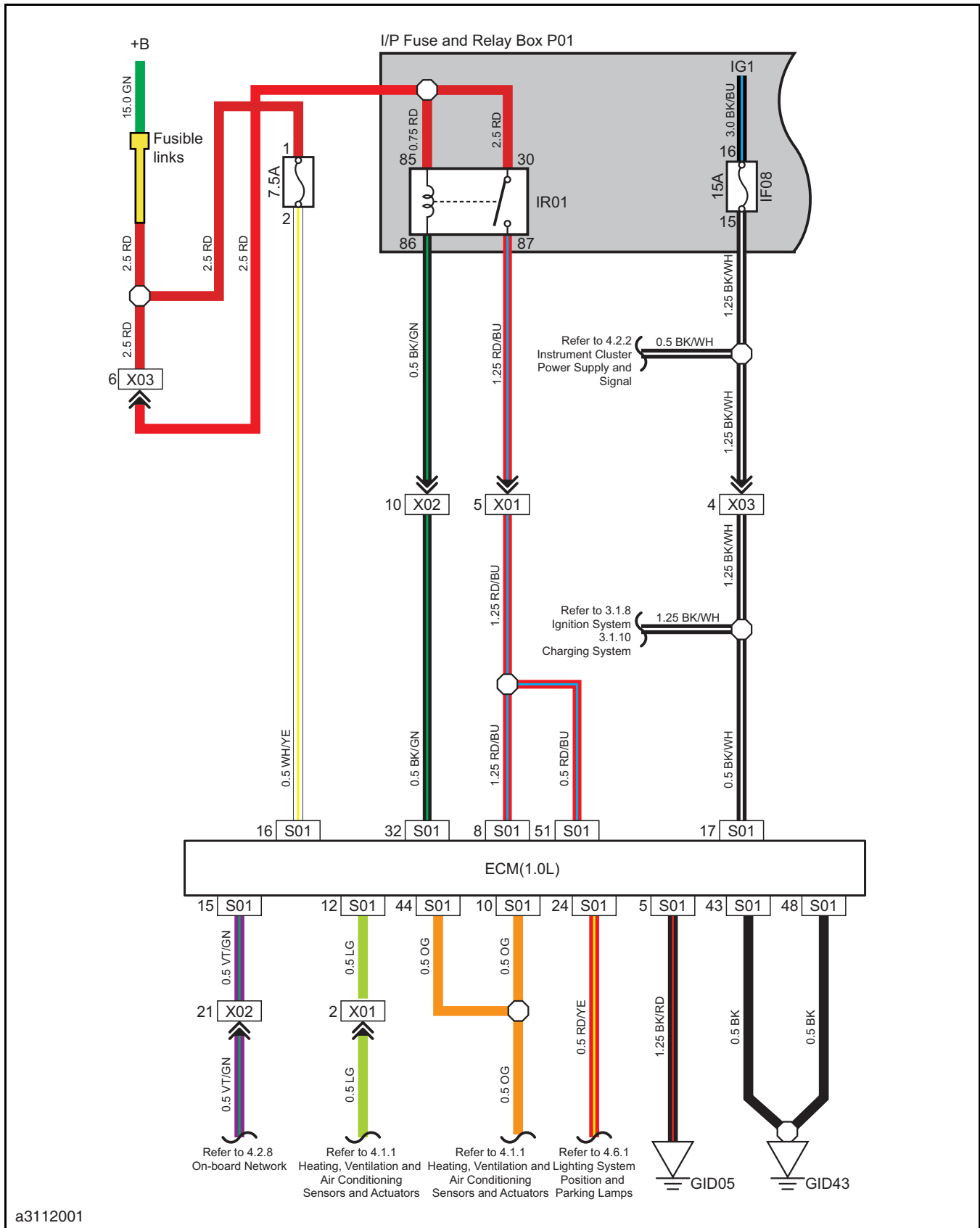

a3112001

Throtte Position Sensor Connector

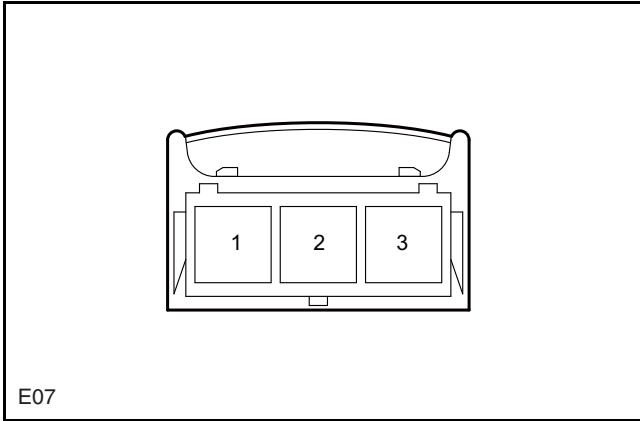

Coolant Temperature Sensor Connector

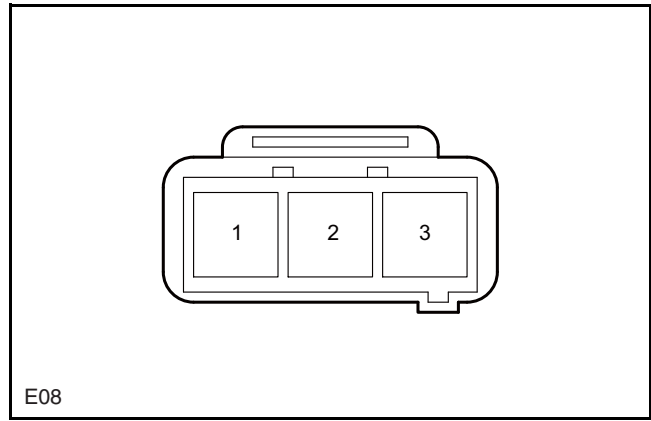

Camshaft Position Sensor Connector

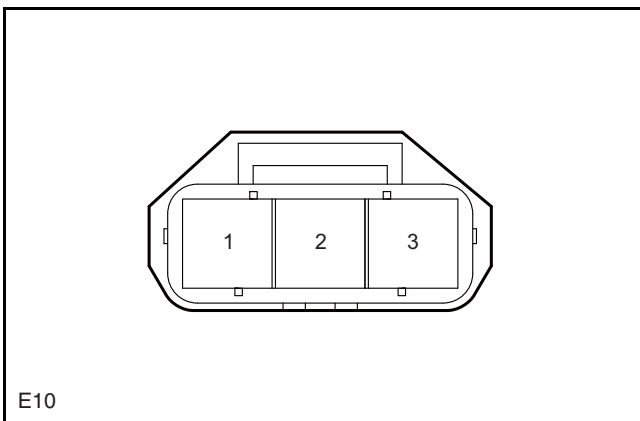

Instrument Cluster Connector A

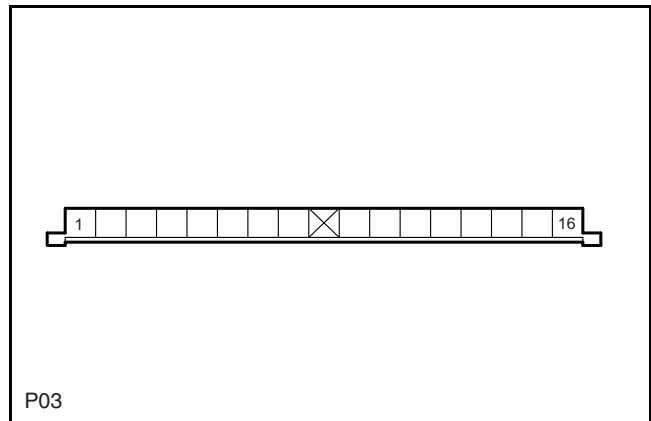

Instrument Cluster Connector B

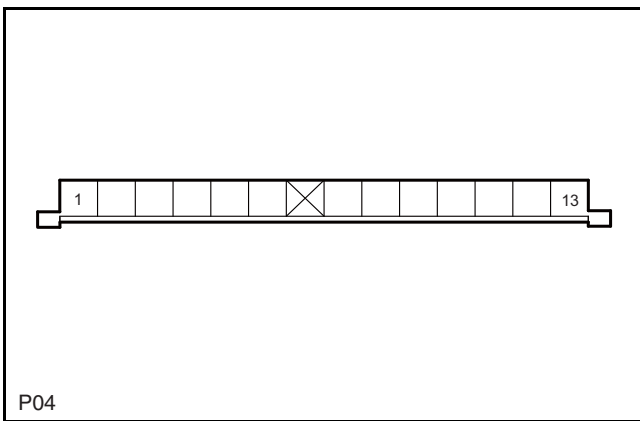

Evaporator Temperature Sensor Connector

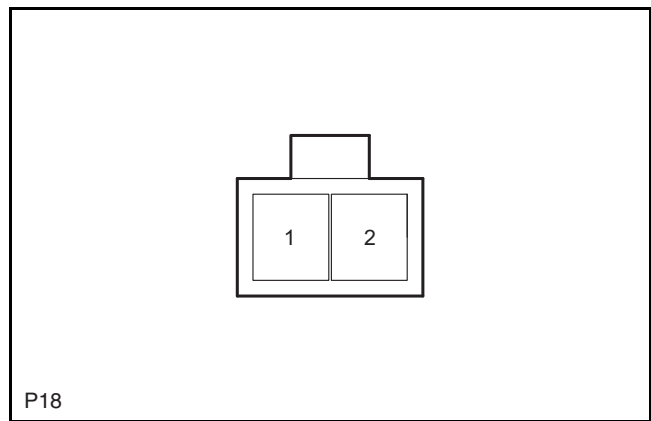

Thermal Protection Switch Connector

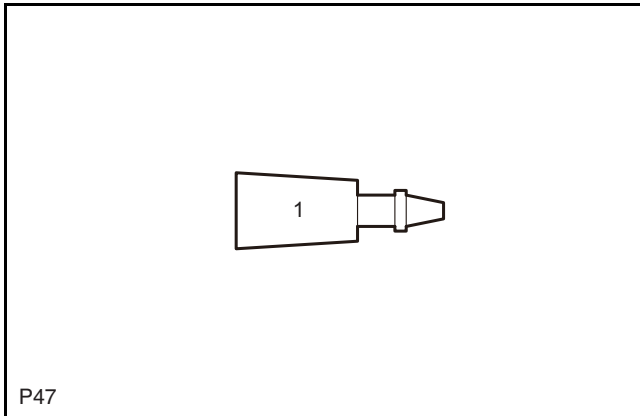

A/C Compressor Relay Connector

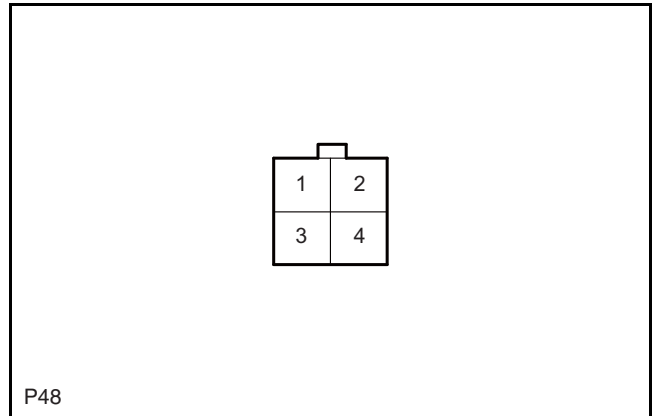

ECM (1.0L)

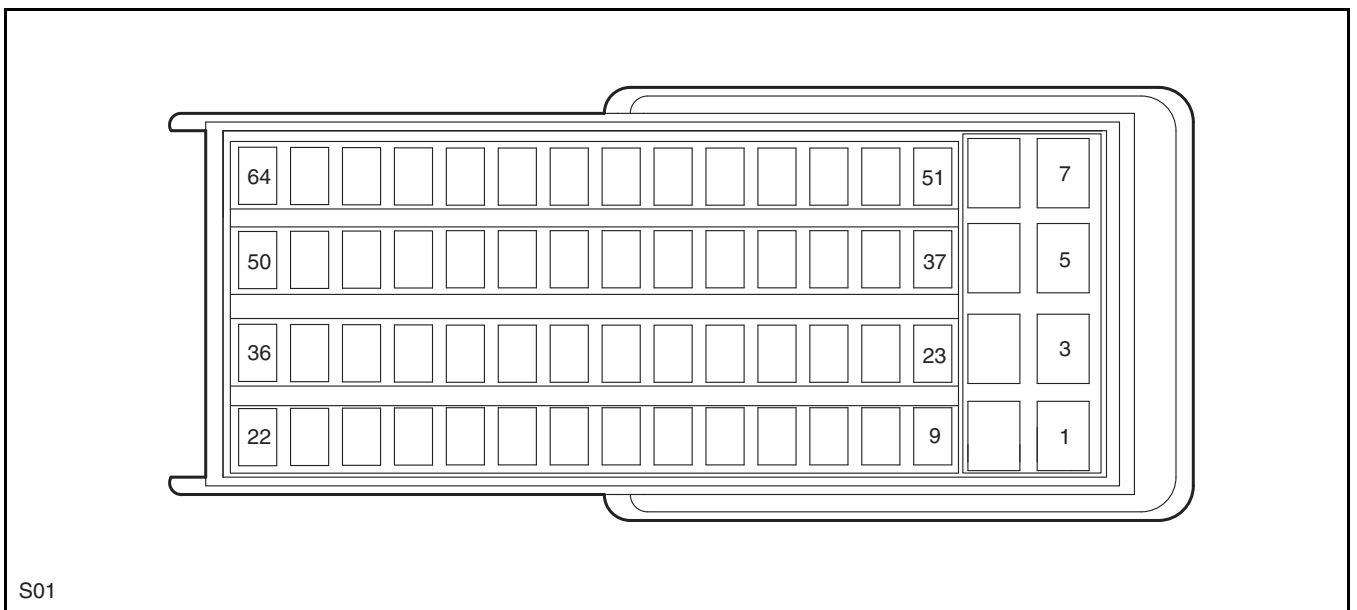

ECM (1.3L)

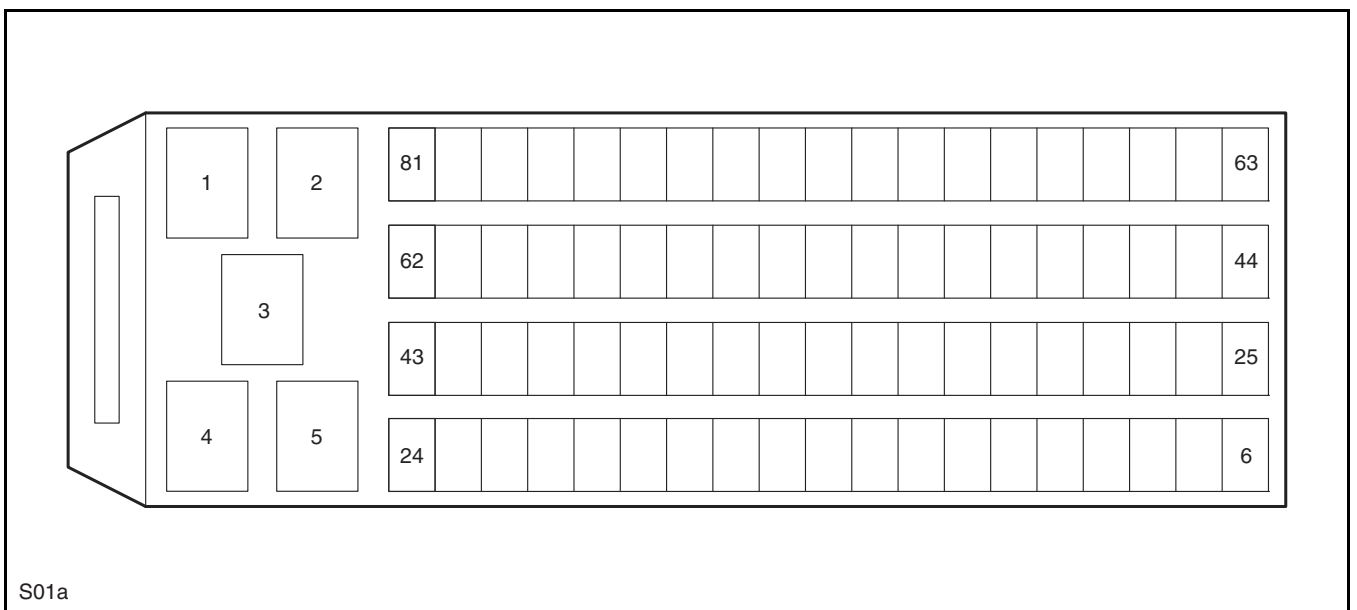

Left Speaker Connector

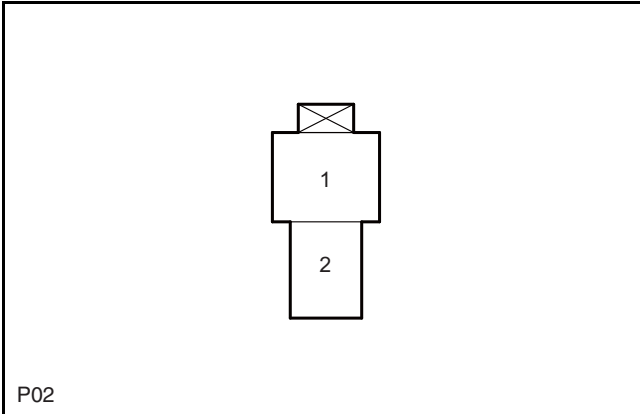

Radio Connector A

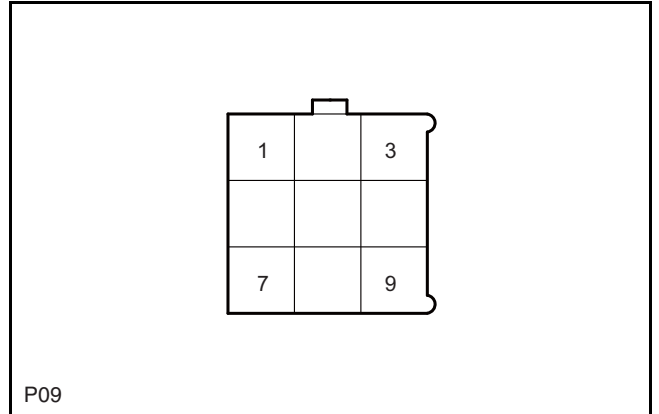

Radio Connector B

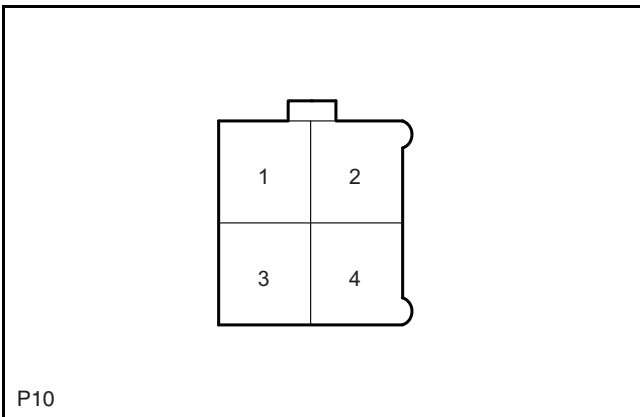

Right Speaker Connector

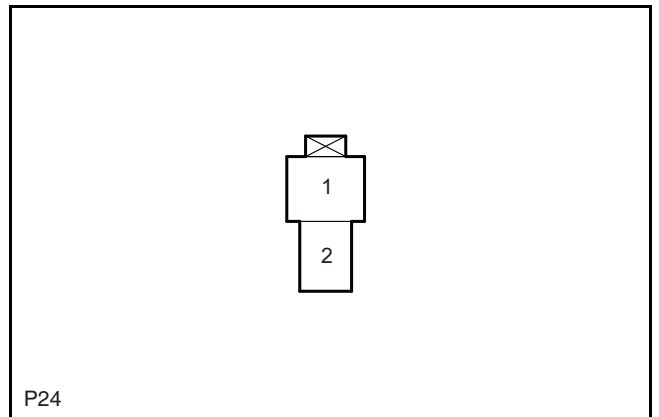

DLC (1.3L)

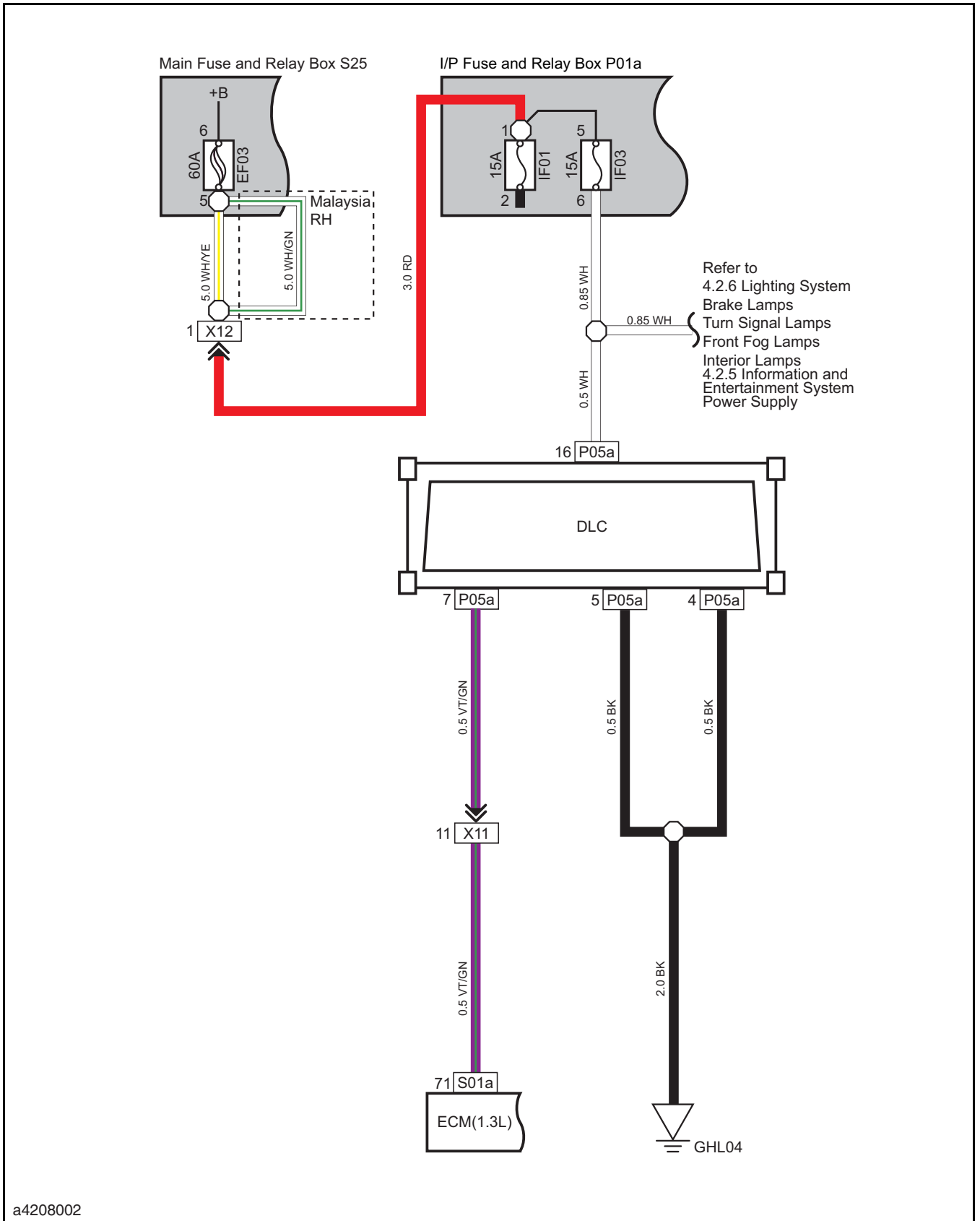

a4208002

EF01 EF03 EF05 EF06 EF07 EF08 ER01 ER02 ER03 ER04 (1.3L)

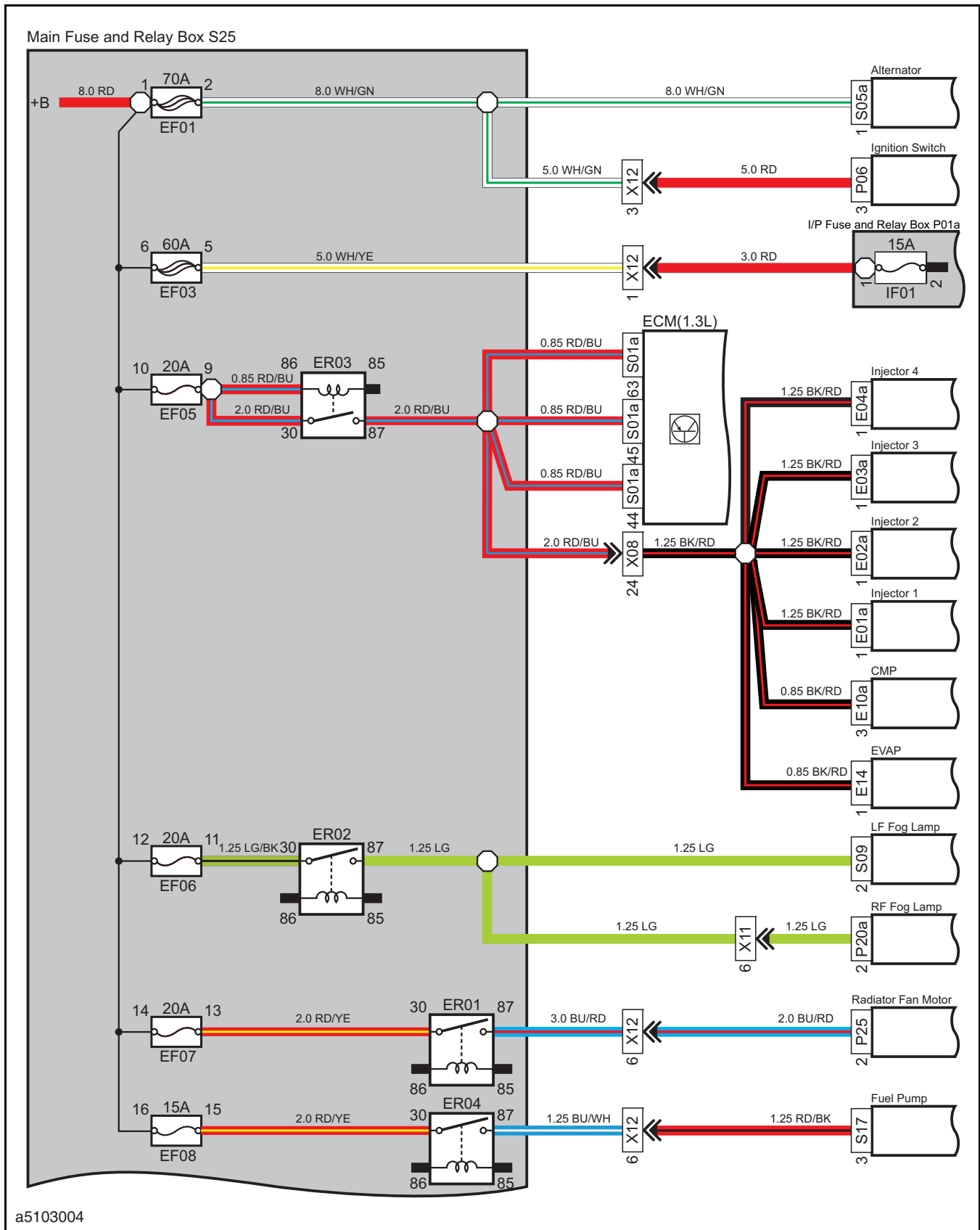

I/P Harness Connector (P--)

I/P Harness Connector (P--)

(1.0L)

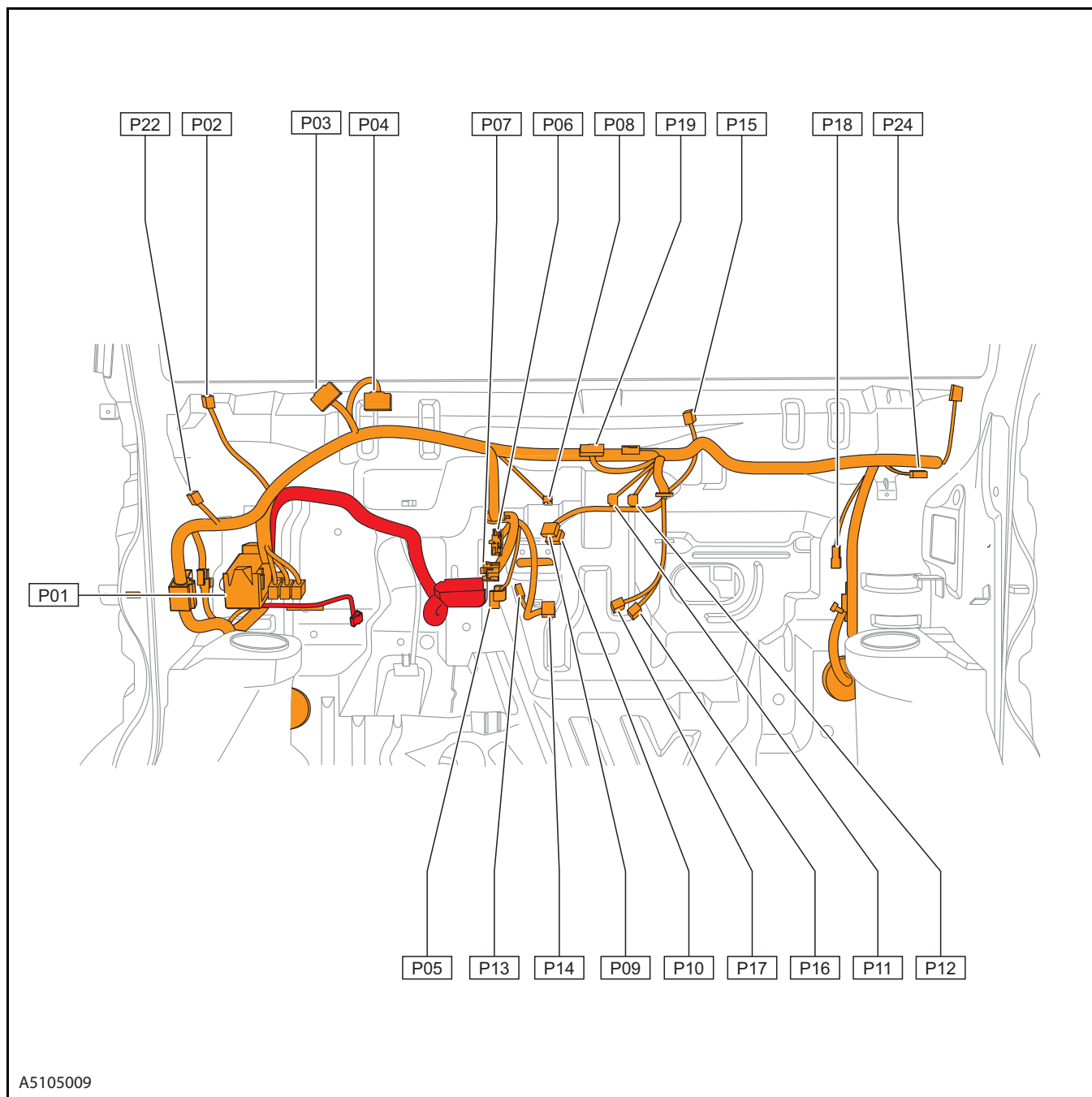

A5105009

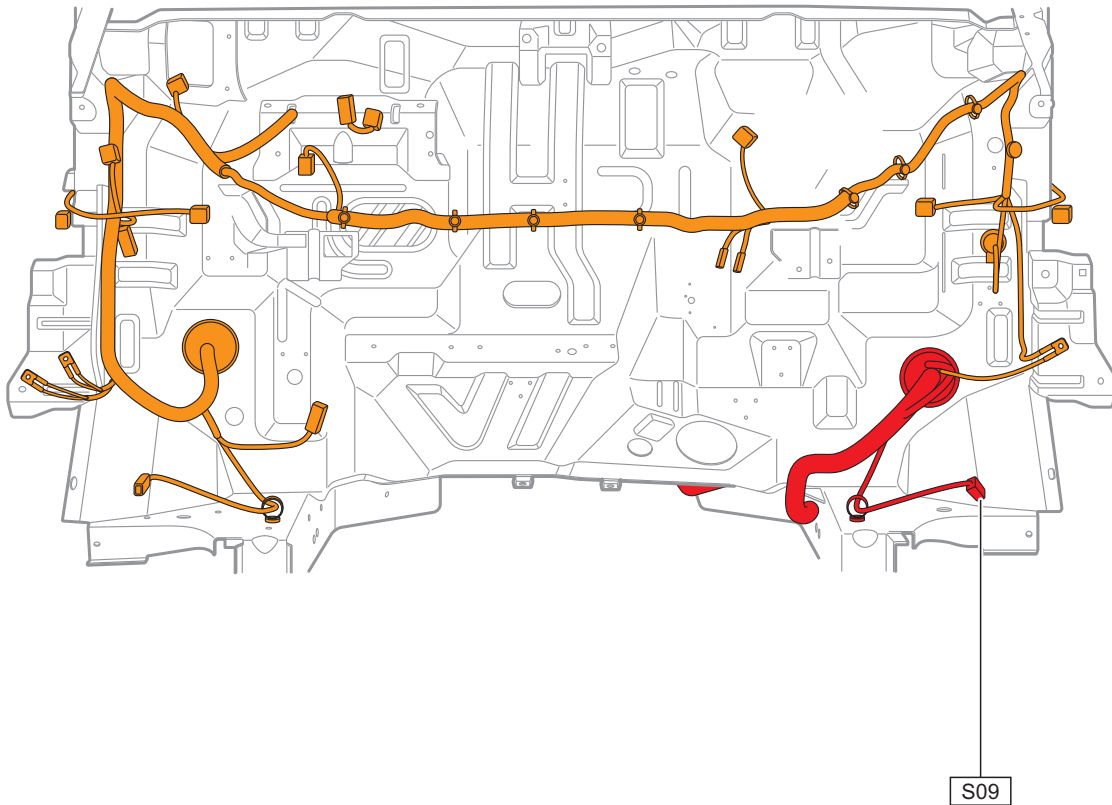

A5105027

GAC04

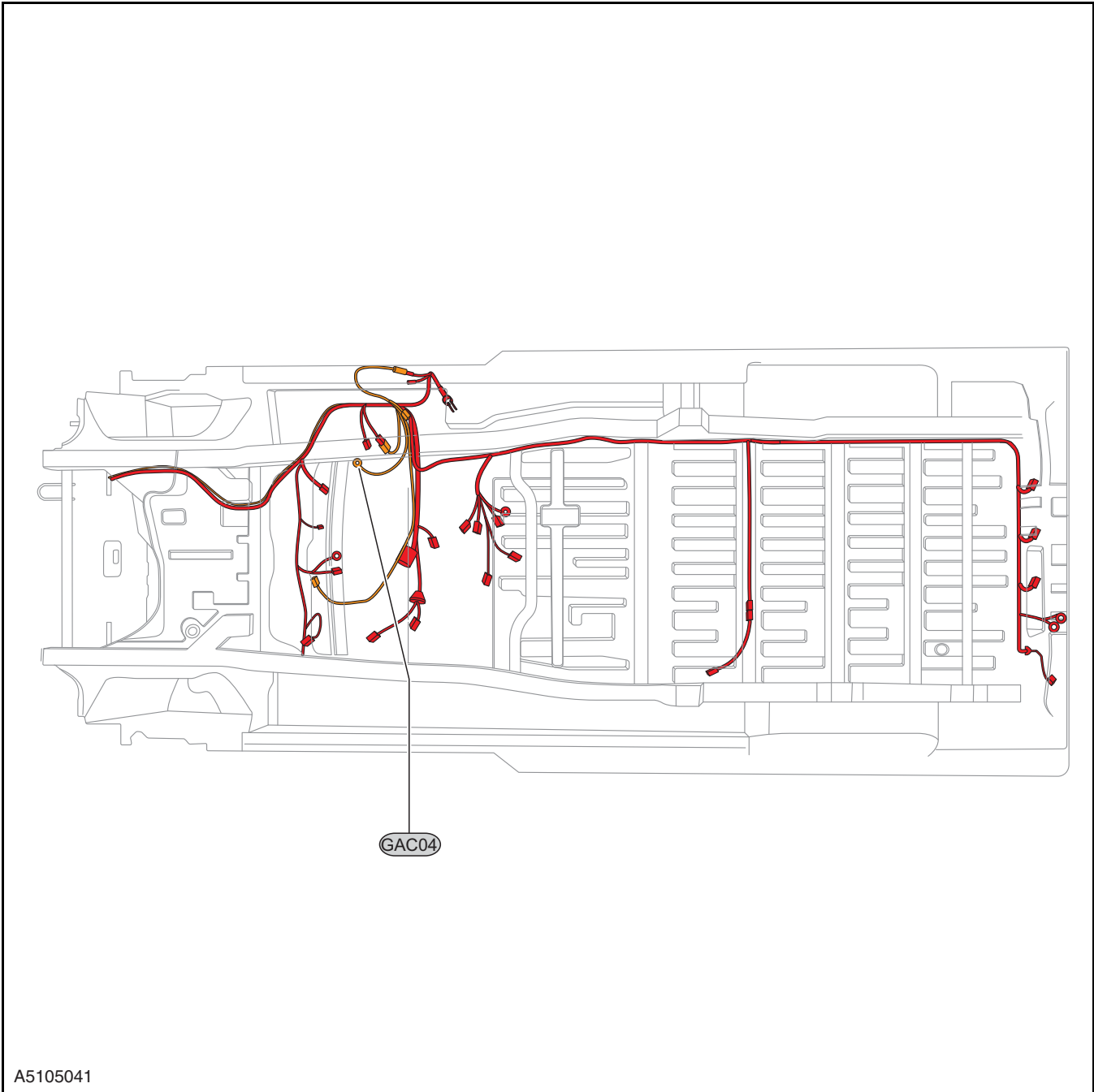

A5105041

Turn Signal Lamp Relay Connector

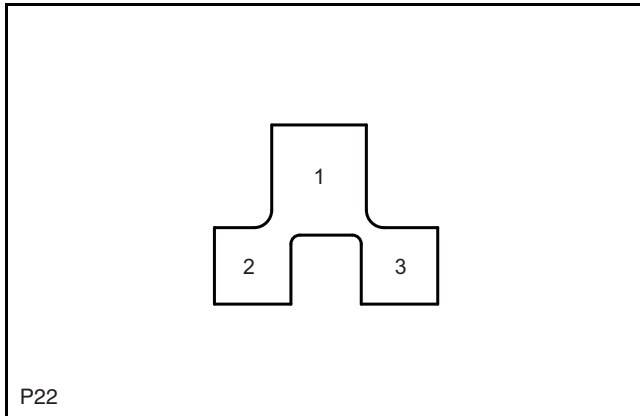

P22 Pin Definition

Pin Number	Wire Width/Color	Function
1	0.5 GN	Turn signal combination switch control input
2	0.5 BK	Ground
3	0.5 YE/GN	Power supply (+B or IG1)

Front Windshield Wiper Motor Connector

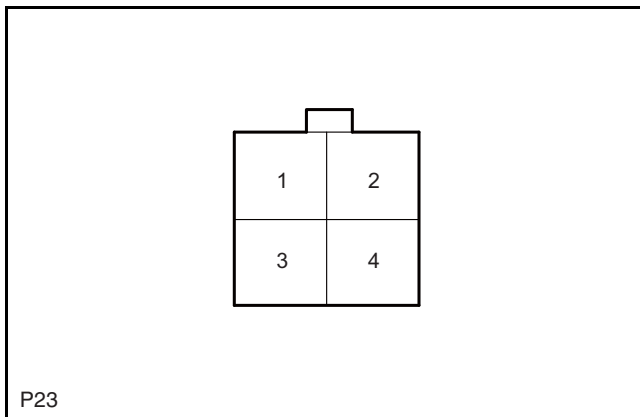

P23 Pin Definition

Pin Number	Wire Width/Color	Function
1	0.85 BU/RD	Front Windshield motor control - High speed
2	0.85 BU	Front Windshield motor control - Low speed
3	0.85 BU/WH	Front Windshield motor control - Intermittent
4	0.85 YE/BU	Power supply