



## 00 – Technical data

### 1 Technical data

(VRL011463; Edition 02.2018)



Note

The term “common rail” means that all injectors on one cylinder bank have the “same” fuel rail. Pressure generation and fuel injection are separate in this system: a separate high-pressure pump generates the high-pressure required for injection. This is stored in a fuel rail and is supplied to the injectors via short injection lines.

Engine number ⇒ [page 1](#) .

Engine data ⇒ [page 1](#) .

#### 1.1 Engine number

The engine number (including engine code and serial number) can be found on the inner part of the block below the intake manifold (left side).

The engine codes have four characters, starting with the letter “C”.

The first 3 characters stand for the engine's cubic capacity and mechanical structure. They are stamped into the cylinder block together with the serial number.

The fourth character denotes the engine's performance and torque rating and depends on the engine control unit.

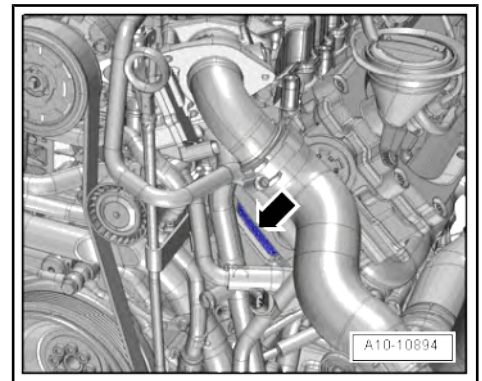

Note

Vehicles for certain export countries have no type plate. Locations of vehicle data plate and data sticker ⇒ Maintenance manual .

#### 1.2 Engine data

Codes	CKDA
Manufactured	03.10 ▶
Exhaust emissions fulfil	EU5 standard
Displacement	l
Power	kW at rpm
Torque	Nm at rpm
Bore	Diameter, mm
Stroke	mm
Compression ratio	
Fuel:	acc. to
Firing order	
Exhaust gas recirculation	
Charging	
Catalytic converter	
Particulate filter	
Intercooler	



- Open plug-in connector -A- under the coolant expansion tank and pull off coolant hose.
- Unscrew connection of coolant hose at top of radiator.

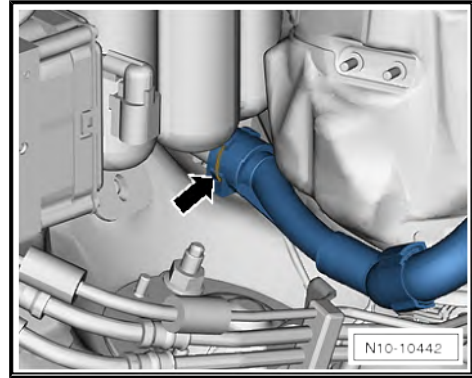

- Open plug-in connector -A- at top of radiator and pull coolant hose off.
- Remove front wheels.

**Leave vehicle in raised position**

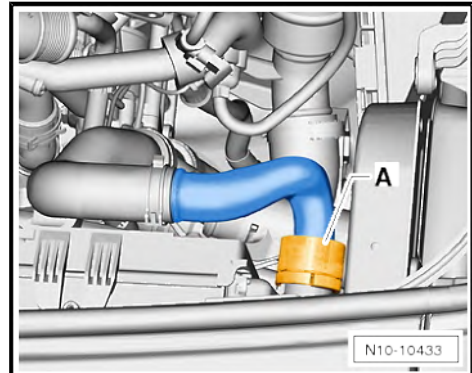

- Open clamp -A- and quick-release coupling -B-, and remove charge air hoses on left and right.

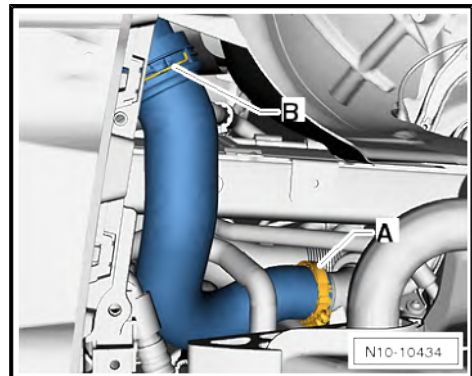

- Unscrew earth connection -A- on right longitudinal member.

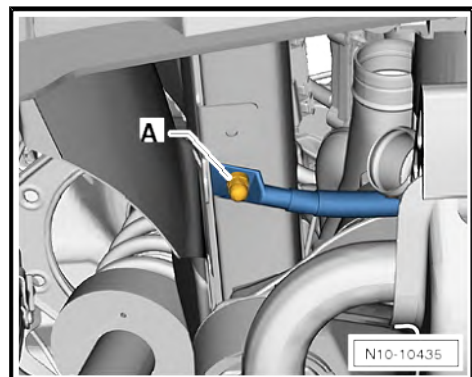



- Unscrew bolt -1-.
- Release hose clip -arrow- and detach air pipe (right-side) with air hose towards front.

#### With engine installed

- Support engine in its installation position ⇒ [page 34](#) .

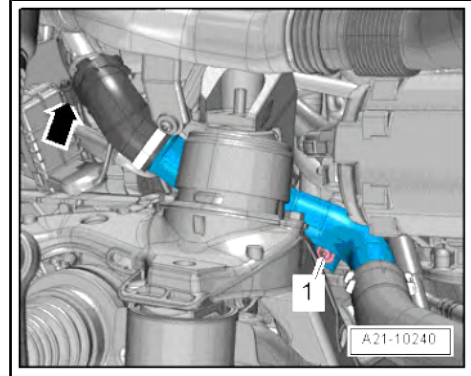

- Unscrew nut -arrow-. Raise engine with threaded spindle until engine support (right-side) is positioned above stud of engine mounting (right-side).
- Remove bolt -1- from right engine support and remove it.

#### With engine removed

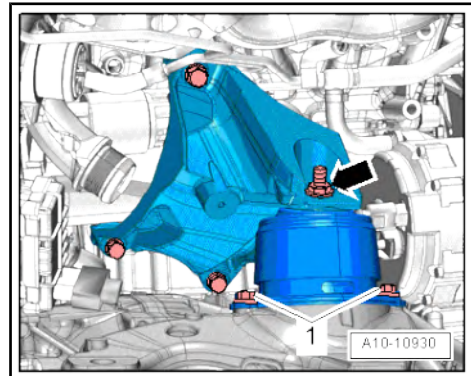

- Unscrew nut -arrow-. Raise engine using workshop hoist via lifting eye on right-hand side until right-hand engine support is positioned above stud of right-hand engine mounting.
- Remove bolt -1- from right engine support and remove it.

#### Continuation for both methods of removal

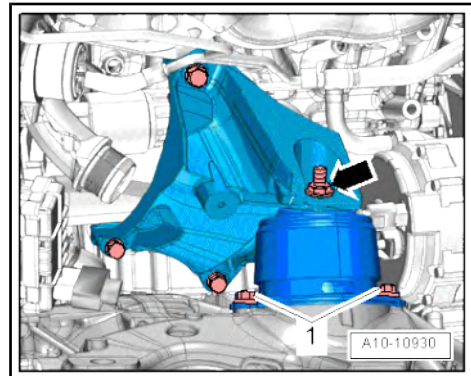

- Remove bolts -arrows- and remove engine support on right.

#### Installing

Install in reverse order of removal, observing the following:

- ◆ Specified torques  
⇒ [“2.1 Assembly overview - assembly mountings”, page 37](#)

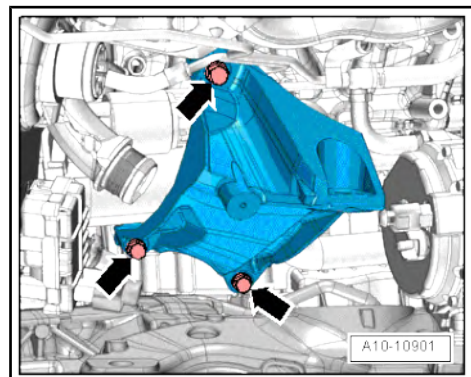



## 13 – Crankshaft group

### 1 Cylinder block (pulley end)

Assembly overview - poly V-belt drive ⇒ [page 41](#) .

Removing and installing poly V-belt ⇒ [page 42](#)

Removing and installing poly V-belt tensioner ⇒ [page 43](#) .

Removing and installing vibration damper ⇒ [page 44](#)

Assembly overview - oil seal and sealing flange on pulley end  
 ⇒ [page 45](#)

Renewing oil seal for crankshaft on pulley end ⇒ [page 46](#)

Removing and installing sealing flange on pulley end  
 ⇒ [page 48](#)

#### 1.1 Assembly overview - poly V-belt drive

##### 1 - Poly V-belt

- Check for wear
- Before removing, mark direction of rotation with chalk or felt-tipped pen
- Removing and installing ⇒ [page 42](#)
- When installing, make sure it is properly seated on poly V-belt pulleys.

##### 2 - Bolt

- Specified torque ⇒ Electrical system; Rep. gr. 27

##### 3 - Alternator

- Removing and installing ⇒ Electrical system; Rep. gr. 27

##### 4 - Bolt

- 50 Nm

##### 5 - Bolt

- Specified torque ⇒ Rep. gr. 87

##### 6 - Air conditioner compressor

- Removing and installing ⇒ Rep. gr. 87

##### 7 - Dowel sleeve

- Qty. 2
- Check for correct seating in mounting plate

##### 8 - Poly V-belt tensioner

- Removing and installing ⇒ [page 43](#)

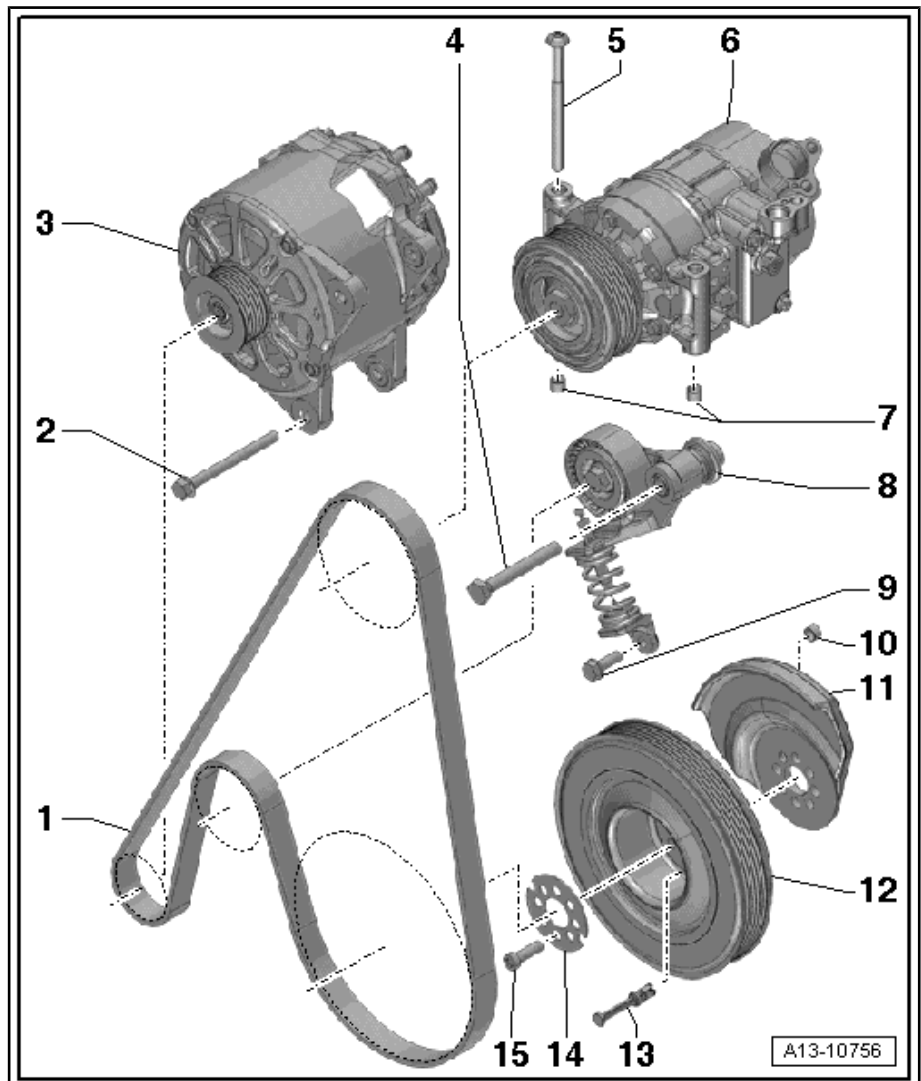



- Remove plenum chamber bulkhead on left ⇒ Rep. gr. 50 .
- Remove toothed belt, and detach toothed belt pulley ⇒ [page 252](#) .

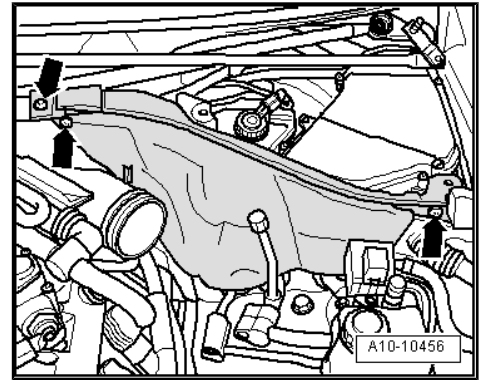

- Lever out oil seal using extractor hook - 10 - 221- -arrow-.

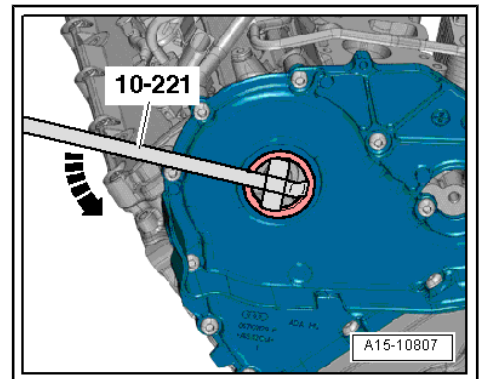

- Push in oil seal -1- using assembly device - T10053- .

Now continue installing in reverse order of removal, observing the following:



*Replace oil seals and O-rings.*

- Install toothed belt pulley and toothed belt ⇒ [page 252](#) .
- Install plenum chamber partition panel (left-side) and cowl panel cover ⇒ Rep. gr. 50 .
- Install and adjust windscreen wiper arms ⇒ Electrical system; Rep. gr. 92 .

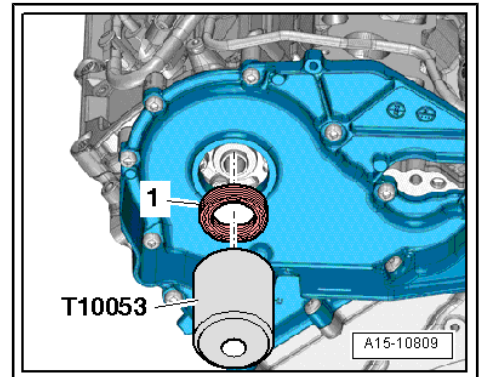

### 1.3 Removing and installing timing chain cover (left)

#### Special tools and workshop equipment required

- ◆ Hand drill with plastic brush
- ◆ Safety glasses
- ◆ Sealant ⇒ Electronic Parts Catalogue



**Caution**

*Avoid damage to valves and piston crowns.*

- ◆ *When turning camshaft, crankshaft must be positioned so that no piston is positioned at "TDC".*



**Note**

*If the camshafts cannot be locked in place, correct their position slightly with the adapter - T40061-. To do this, screw the 4 indicated bolts for camshaft sprocket into the camshaft -arrows-.*

- Install left camshaft timing chain with camshaft sprocket, guide rail and tensioning rail.
- Elongated holes in camshaft sprocket must be aligned centrally with threaded holes in camshaft.
- Tighten bolts -1- and -3- for guide rail and tensioning rail.
- Screw both bolts -2- for camshaft sprocket in loosely.
- It should just be possible to turn camshaft sprocket on camshaft without axial movement.
- Lock left camshaft with adjustment pin - T40060- .
- Side pin -arrow- on adjustment pin - T40060- must be parallel to a radius vector of camshaft.
- Pull drill -4- out of locating hole, this releases the left chain tensioner.
  
- Install right camshaft timing chain with camshaft sprocket and chain tensioner.
- Elongated holes in camshaft sprocket must be aligned centrally with threaded holes in camshaft.
- Tighten bolts -1- for chain tensioner.
- Screw both bolts -2- for camshaft sprocket in loosely.
- It should just be possible to turn camshaft sprocket on camshaft without axial movement.
- Lock right camshaft with adjustment pin - T40060- .
- Side pin -arrow- on adjustment pin - T40060- must be parallel to a radius vector of camshaft.
- Pull locking pin - T40071- out of locating hole, this releases the chain tensioner (right-side).

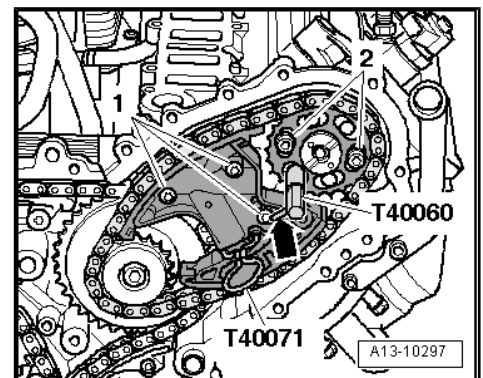
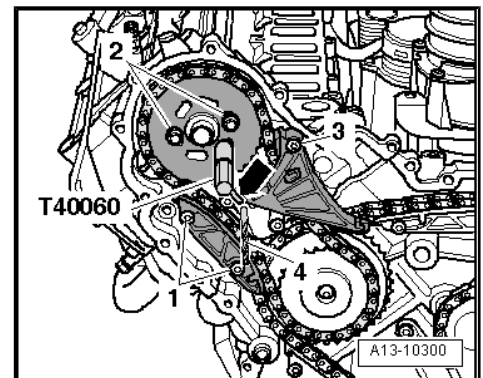
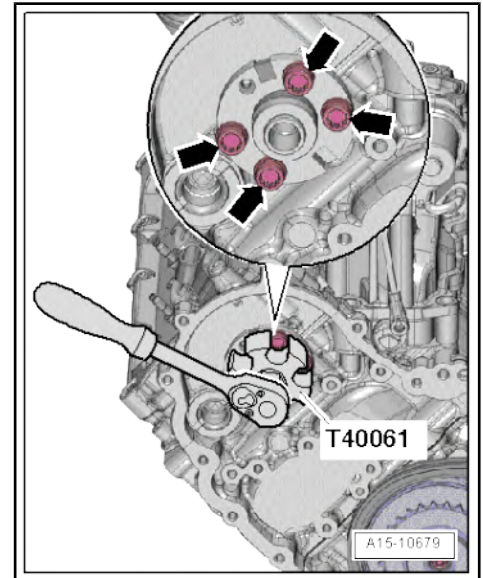



◆ Seal puller - T40195-

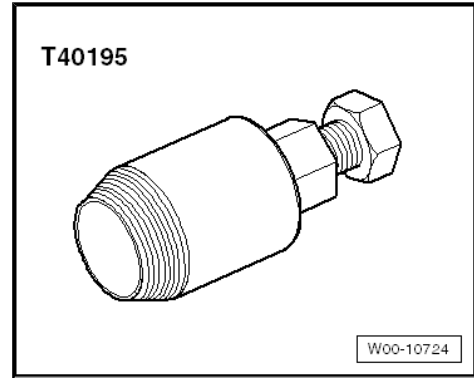

**Procedure**

- Remove vane pump ⇒ Rep. gr. 48 .
- Screw out spindle of oil seal extractor -T40195- as far as it will go.
- Lubricate threaded head of oil seal extractor, place it in position and, exerting firm pressure, screw it into oil seal for vane pump drive as far as possible.
- Turn inner section of oil seal extractor against the spur gear drive until the shaft oil seal has been extracted.

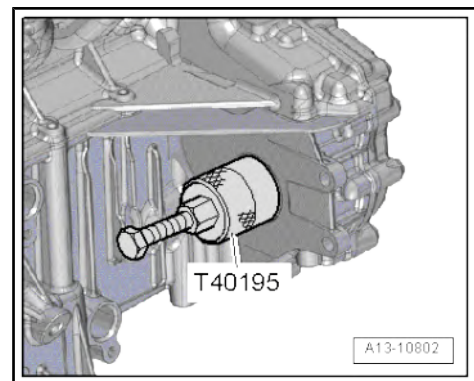

**i Note**

*If the shaft oil seal splits, fit oil seal extractor again and extract the remainder of the shaft oil seal.*

- Clamp oil seal extractor on hexagon flats in a vice and remove shaft seal using pliers.
- Clean contact surface and sealing surface.
- Use thrust piece -T40193- to push shaft oil seal for vane pump drive in as far as it will go.
- Install vane pump ⇒ Rep. gr. 48 .

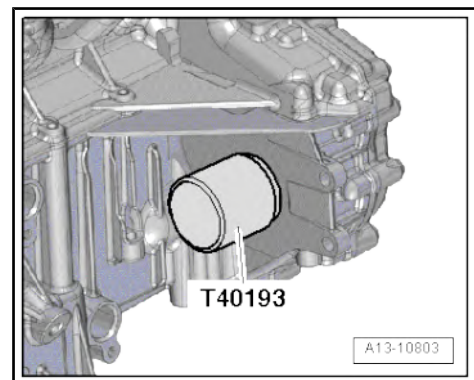



## 2.10 Removing and installing spur gear drive

### Removing

- Engine/gearbox assembly removed ⇒ [page 3](#) ; engine separated from gearbox ⇒ [page 17](#) ; engine attached to engine and gearbox support ⇒ [page 26](#) .
- Remove lower timing chain cover ⇒ [page 75](#) .

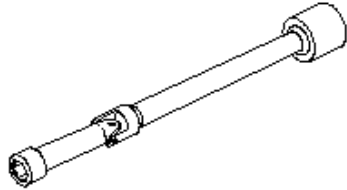
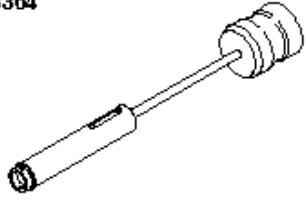
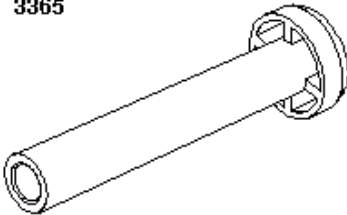

**Special tools and workshop equipment required**

<p>3220</p> 	<p>3364</p> 
<p>3365</p> 	<p>VAS 5161</p> 
<p style="text-align: right;">G15-0017</p>	

- ◆ U/J extension and socket, 10 mm - 3220-
- ◆ Valve stem seal puller - 3364-
- ◆ Valve stem seal fitting tool - 3365-
- ◆ Removal and installation device for valve cotters - VAS 5161- with guide plate -VAS 5161/24- and sleeve -VAS 5161/24-1-

**Procedure**

- Remove all glow plugs ⇒ [page 309](#) .
- Remove camshafts ⇒ [page 127](#) .
- Mark allocation of roller rocker fingers and hydraulic compensation elements for reinstallation.
- Remove roller rocker fingers together with hydraulic compensation elements and place down on a clean surface.

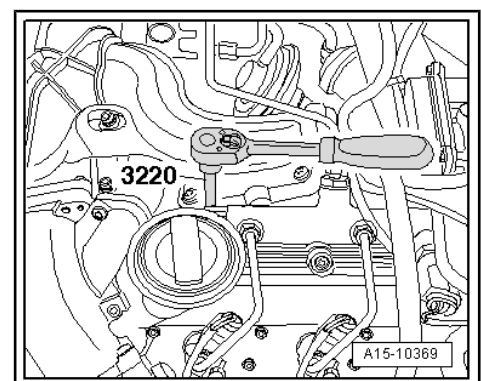





### 19 - Bolt

- Renew
- Tighten mountings from centre outwards
- 8 Nm + turn 90° further

### Oil pressure switch - F22- / oil pressure switch for reduced oil pressure - F378- and oil temperature sender - G8- - Specified torques

- Tighten oil pressure switch for reduced oil pressure - F378- -item 1- to 20 Nm.
- Tighten oil temperature sender - G8- -item 2- to 2 Nm.
- Tighten oil pressure switch - F22- -item 3- to 20 Nm.

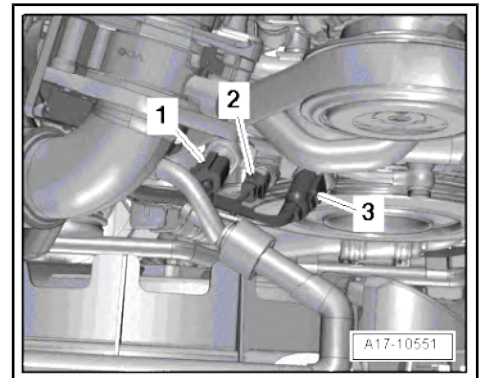

## 3.2 Removing and installing engine oil cooler

### Removing

- Drain coolant ⇒ [page 177](#) .
- Drain refrigerant circuit ⇒ Air conditioner - refrigerant R134a .
- Remove upper part of intake manifold ⇒ [page 268](#) .
- Remove air conditioner compressor ⇒ Rep. gr. 87 .
- Remove right coolant pipe for exhaust return.

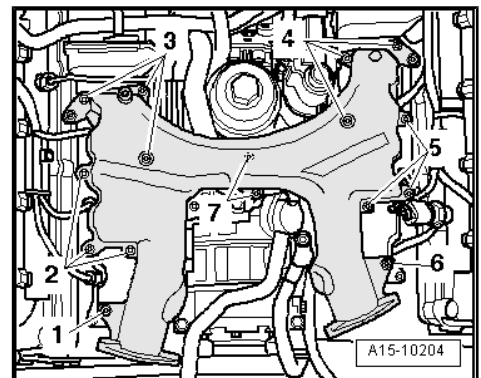

- Disconnect crankcase breather pipe from hoses -arrows- and detach.

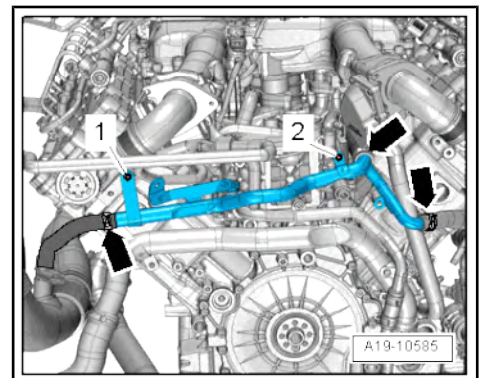



- Unscrew securing bolts -1- and -2-.

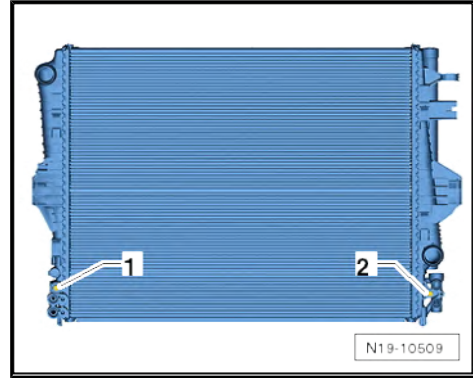

- Turn radiator module over. Press locking mechanism -1- and swing out gear oil cooler.

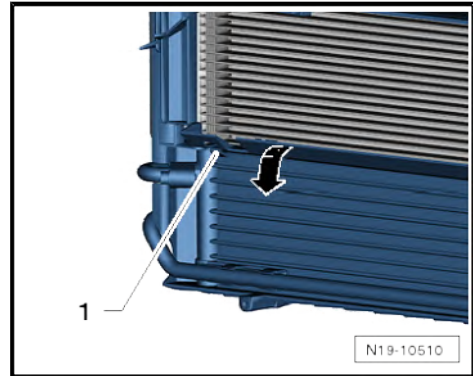

- Unscrew bolts -arrows- and remove bracket -1- and then swing out hydraulic oil cooler.

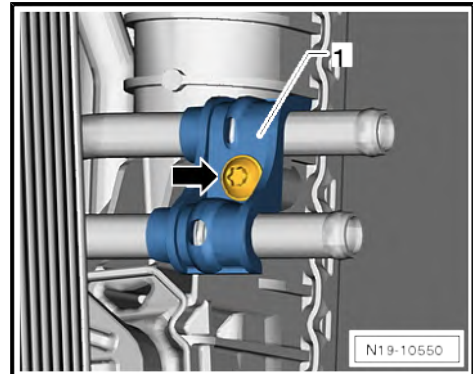

- Remove clamps -A-, lift condenser a little and remove from radiator in direction of arrow.

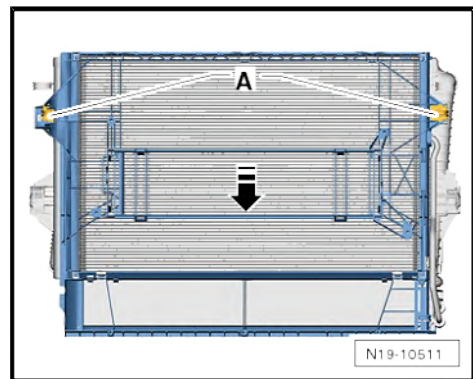



- Unscrew securing bolts -1 ... 3-, and detach radiator.

### Installing

Install in reverse order of removal, observing the following.

#### Note

- ◆ *Hose connections and hoses for charge air system must be free of oil and grease before assembly.*
- ◆ *Secure all hose connections with the hose clips corresponding to original equipment ⇒ Electronic Parts Catalogue .*

- Installing front bumper cover ⇒ Rep. gr. 63 .
- Install front noise insulation ⇒ Rep. gr. 50 .

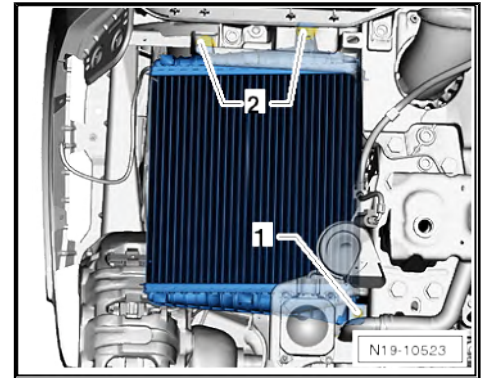

## 3.4 Removing and installing intake air temperature sender - G42- with charge air pressure sender - G31-

### Removing

- Detach connector from intake air temperature sender - G42- with charge air pressure sender - G31- .
- Undo bolts -arrows- and pull intake air temperature sender - G42- together with charge air pressure sender - G31- out of the connection piece.

### Installing

- Specified torque ⇒ [page 215](#) .

Install in reverse order of removal, observing the following.

#### Note

*Renew O-ring.*

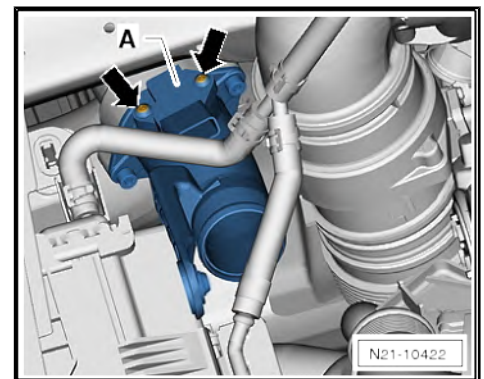

## 3.5 Checking charge air system for leaks

### Special tools and workshop equipment required

- ◆ Charge air system tester - V.A.G 1687-

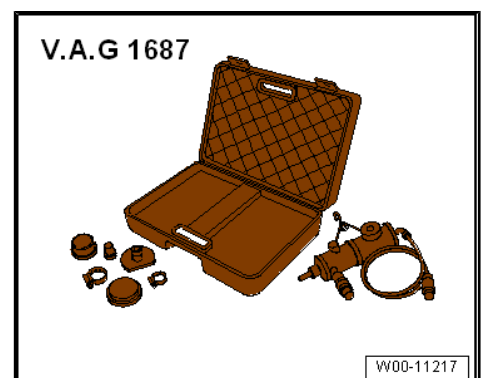

- ◆ Adapter - 1687/12-
- ◆ Plug - V.A.G 1687/17-



If fuel line (between fuel tank and high-pressure fuel pump) or the fuel filter are removed or renewed, perform the guided function "actuating fuel pump" before first starting engine.

If the high-pressure fuel pump is removed or renewed, the guided function "fuel pump activation" must be carried out before engine is started for first time.

Performing first fuel filling after installing high-pressure pump  
⇒ [page 265](#) .



### Note

Failure to fill the high-pressure pump with fuel will result in damage to the pump.

#### 1 - Fuel metering valve - N290-

- ❑ Do not unscrew.

#### 2 - High-pressure pump

- ❑ With gear-type pre-supply pump.
- ❑ After pump renewal, the fuel tank must be filled (never allow pump to operate while tank is empty) ⇒ [page 265](#) .
- ❑ Removing and installing ⇒ [page 259](#)

#### 3 - High-pressure accumulator (rail)

- ❑ Cylinder bank 1

#### 4 - Fuel pressure regulating valve - N276-

- ❑ On cylinder bank 1
- ❑ Renew after each removal
- ❑ Installing and removing ⇒ [page 262](#)

#### 5 - Fuel pressure sender - G247-

- ❑ On cylinder bank 2
- ❑ Installing and removing

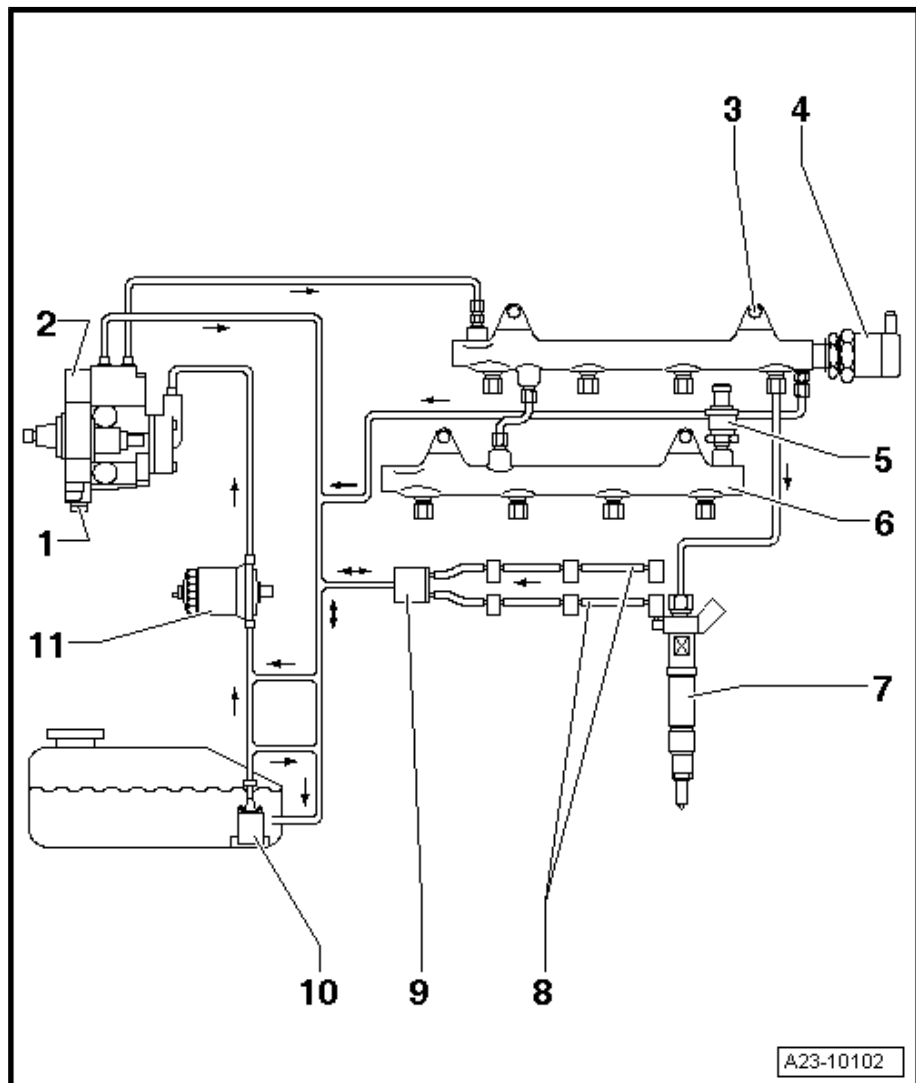

A23-10102



- In order to pull off injectors if they prove difficult to gain access to, fit U-shaped jig -T40059/3- with bolt -1- between puller - T10055- and adapter -T10055/1- .
- Place removed injectors on a clean cloth.

### Installing used injectors

When re-installing, the following must be replaced:

- ◆ Copper washer
- ◆ O-ring for injector shaft
- ◆ O-ring for injector return line
- Spray tip of injector with anti-seize spray. Wait approx. 5 minutes and wipe off soot particles and oil with a cloth.
- If an injector is very dirty, clean the tip of the injector with a soft brass brush as well in order to facilitate removal of the copper seal.

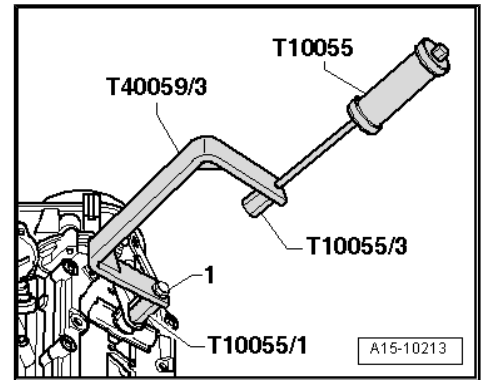

### Note

*It must be ensured that the brass brush does not touch the holes in the injection nozzles.*

- To remove the old copper seal from the injector, clamp the copper seal carefully in a vice so that it is held sufficiently firmly to prevent it from turning. Then carefully pull and twist the injector out of the copper seal by hand.
- Use a scraper to remove any deposits under the copper seal.
- Renew O-rings at all return line connections.

### Note

*Lubricate all O-rings with engine oil or assembly oil before installing.*

- Push the return line connections carefully over the new seals and onto the injectors. You should hear them click into place. Then, carefully press the release pin downwards.



### Caution

***Danger of damage to sealing surface of injector.***

- ◆ ***To remove carbon deposits from the injector sealing surface, clean the injector shaft in the cylinder head with a cloth soaked in engine oil or rust solvent.***

### Installing new injectors

When new injectors are installed, the following must be replaced:

- ◆ Clamping piece
- ◆ Copper washer
- ◆ O-ring for injector shaft
- ◆ O-ring for injector return line
- Lubricate all O-rings with engine oil or assembly oil before installing.



- Unscrew bolts -arrows- and push bracket -1- together with wiring harness to one side.

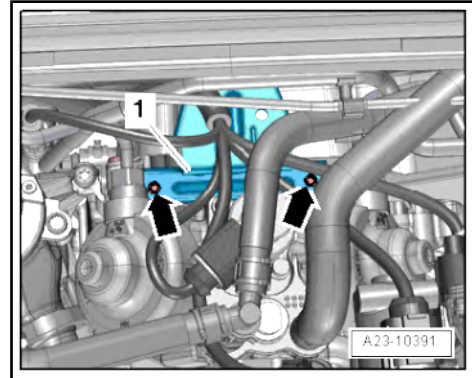

- Remove electrical connectors -1, 2 and 3- from bracket, and push them aside.

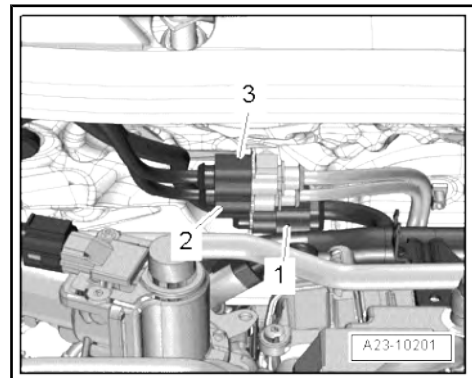

- Unscrew bolts -arrows- and remove toothed belt guard -1-.

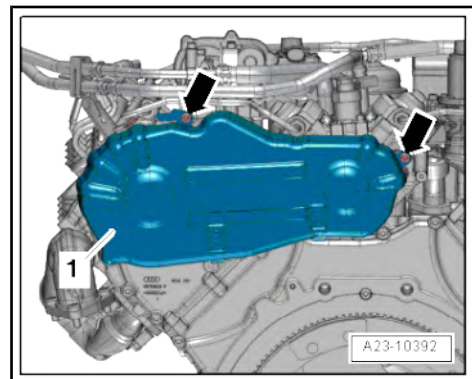

- Loosen bolt -arrow- for toothed belt tensioning roller about 1 full turn.



**Caution**

*Risk of irreparable damage if direction of rotation is reversed on previously used toothed belt.*

- ◆ *Before removing toothed belt, mark direction of rotation with chalk or felt tipped pen for installation purposes.*

- First, remove toothed belt from toothed belt pulley for high-pressure pump and then from toothed belt pulley.

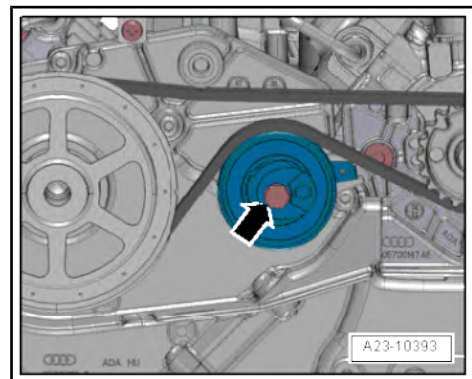



- Unscrew mounting pin for engine cover panel -1- and -6-.
- Unscrew bolts -7- at connection piece for exhaust gas recirculation cooler.
- Unscrew bolts -2 ... 5- and remove upper part of intake manifold.

### Installing

- ◆ Specified torques: assembly overview - intake manifold  
⇒ [page 267](#)

Install in reverse order of removal, observing the following.



### Note

- ◆ *Renew seals.*
- ◆ *Secure all hose connections with the hose clips corresponding to original equipment ⇒ [Parts catalogue](#) .*
- Tighten bolts for upper part of intake manifold and mounting bolts for engine cover panel in stages in alternating diagonal sequence.
- Install high-pressure lines ⇒ [page 249](#) .

## 3.3 Removing and installing lower part of intake manifold on right (cylinder bank 1)

- Remove upper part of intake manifold ⇒ [page 268](#) .
- Remove upper coolant pipe for exhaust return ⇒ Rep. gr. 26 .
- Undo and remove bolts -1- and -4- and carefully push exhaust gas recirculation control motor - V338- together with connection piece to one side until the bolts for lower part of intake manifold on right are accessible.
- Move fuel hose clear.

