

1990 TOYOTA SUPRA REPAIR MANUAL

INTRODUCTION	IN
MAINTENANCE	MA
ENGINE MECHANICAL	EM
EXHAUST SYSTEM	EX
TURBOCHARGER SYSTEM	TC
EMISSION CONTROL SYSTEMS	EC
EFI SYSTEM	FI
COOLING SYSTEM	CO
LUBRICATION SYSTEM	LU
IGNITION SYSTEM	IG
STARTING SYSTEM	ST
CHARGING SYSTEM	CH
CLUTCH	CL
MANUAL TRANSMISSION	MT
AUTOMATIC TRANSMISSION	AT
PROPELLER SHAFT	PR
FRONT AXLE AND SUSPENSION	FA
REAR AXLE AND SUSPENSION	RA
BRAKE SYSTEM	BR
STEERING	SR
SRS AIRBAG	AB
BODY ELECTRICAL SYSTEM	BE
BODY	BO
AIR CONDITIONING SYSTEM	AC
SERVICE SPECIFICATIONS	A
STANDARD BOLT TORQUE SPECIFICATIONS	B
SST AND SSM	C
ELECTRICAL WIRING DIAGRAMS	D

HOW TO USE THIS MANUAL

To assist you in finding your way through the manual, the Section Title and major heading are given at the top of every page.

An **INDEX** is provided on the first page of each section to guide you to the item to be repaired.

At the beginning of each section, **PRECAUTIONS** are given that pertain to *all* repair operations contained in that section. *Read these precautions before starting any repair task.*

TROUBLESHOOTING tables are included for each system to help you diagnose the problem and find the cause. The repair for each possible cause is referenced in the remedy column to quickly lead you to the solution.

REPAIR PROCEDURES

Most repair operations begin with an overview illustration. It identifies the components and shows how the parts fit together.

Example:

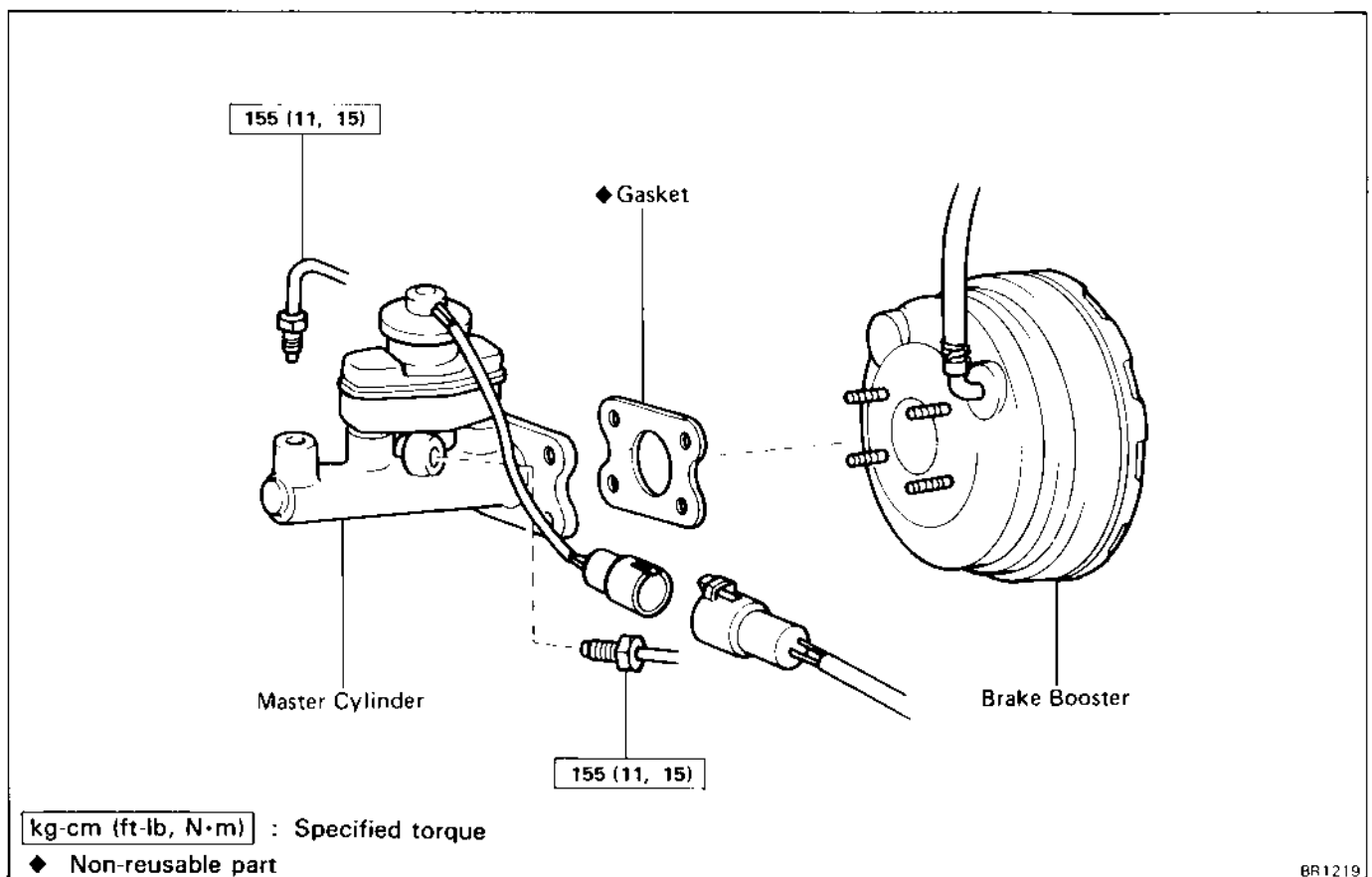

POSITIVE CRANKCASE VENTILATION (PCV) SYSTEM

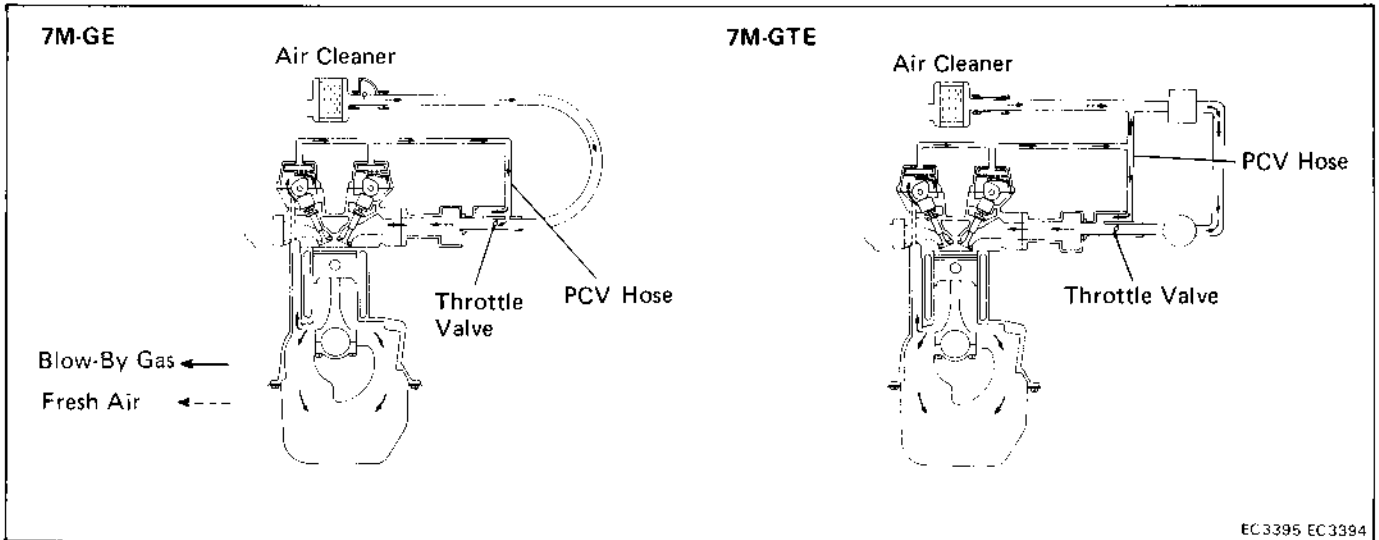

To reduce HC emissions, crankcase blow-by gas (HC) is routed to the intake manifold for combustion in the cylinders.

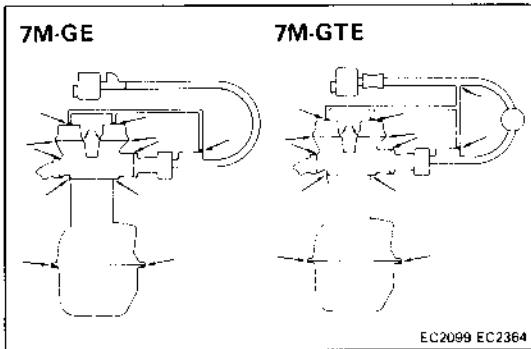

INSPECTION OF PCV HOSE AND CONNECTIONS

1. VISUALLY INSPECT HOSE AND CONNECTIONS

Check for cracks, leaks or damage.

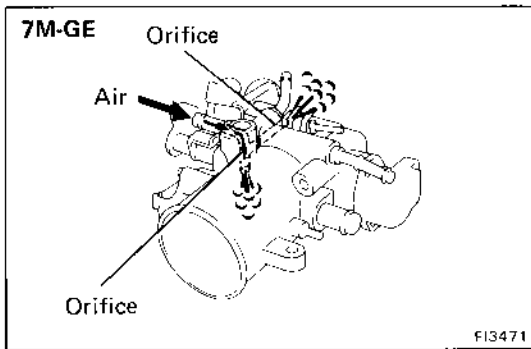

2. CLEAN ORIFICE(S)

Clean off any gum deposits in the orifice(s) with solvent and blow out with compressed air.

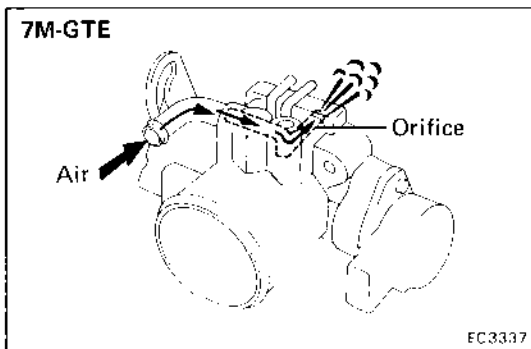

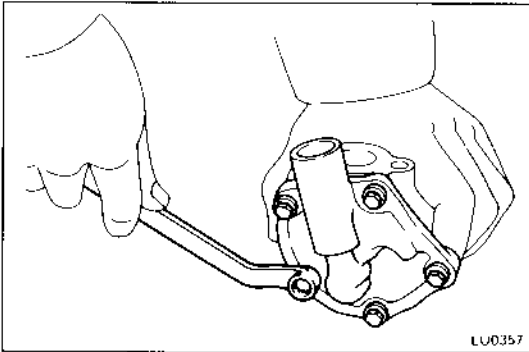

ASSEMBLY OF OIL PUMP

(See page LU-7)

ASSEMBLY OIL PUMP

- (a) Install the drive shaft, spacer, key, shaft gear and snap ring.
- (b) Install the driven gear and pump cover with the five bolts.

Torque: 75 kg-cm (65 in.-lb, 7.4 N·m)

- (c) Install the relief valve and spring in the cover, and screw on the relief valve plug.

Torque: 375 kg-cm (27 ft-lb, 37 N·m)

OPERATION CHECK OF OIL PUMP

1. CHECK PUMP OPERATION

- (a) Immerse the suction end of the pump into clean engine oil and turn the shaft counterclockwise. Oil should come out of the discharge hole.
- (b) Close the discharge hole with your thumb, and turn the shaft as before. The shaft should be difficult to turn.

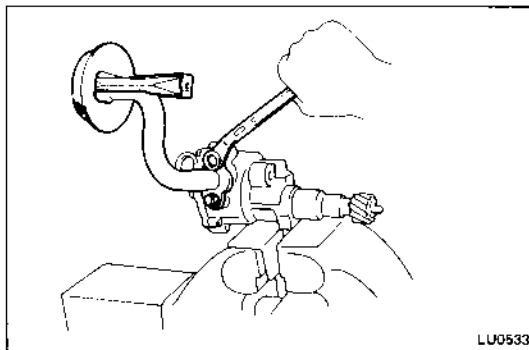
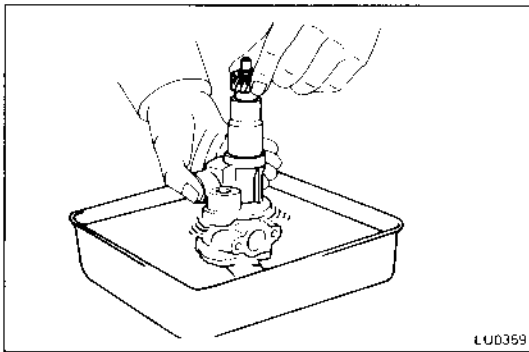
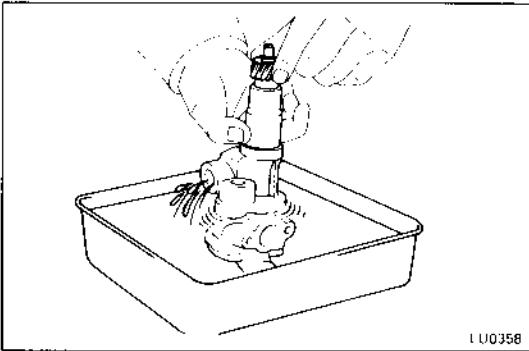

2. INSTALL OIL PUMP STRAINER

- (a) Install a new O-ring to oil pump strainer.
- (b) Install the oil pump strainer with the two bolts.

Torque: 130 kg-cm (9 ft-lb, 13 N·m)

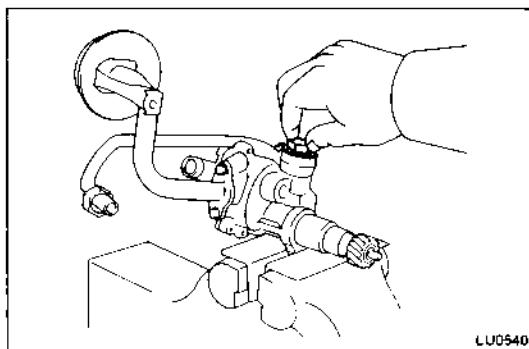

3. INSTALL OIL PUMP OUTLET PIPE

Install the oil pump outlet pipe with a new lock washer, gasket and the union bolt. Finger tighten the union bolt.

Components (R154 Transmission)

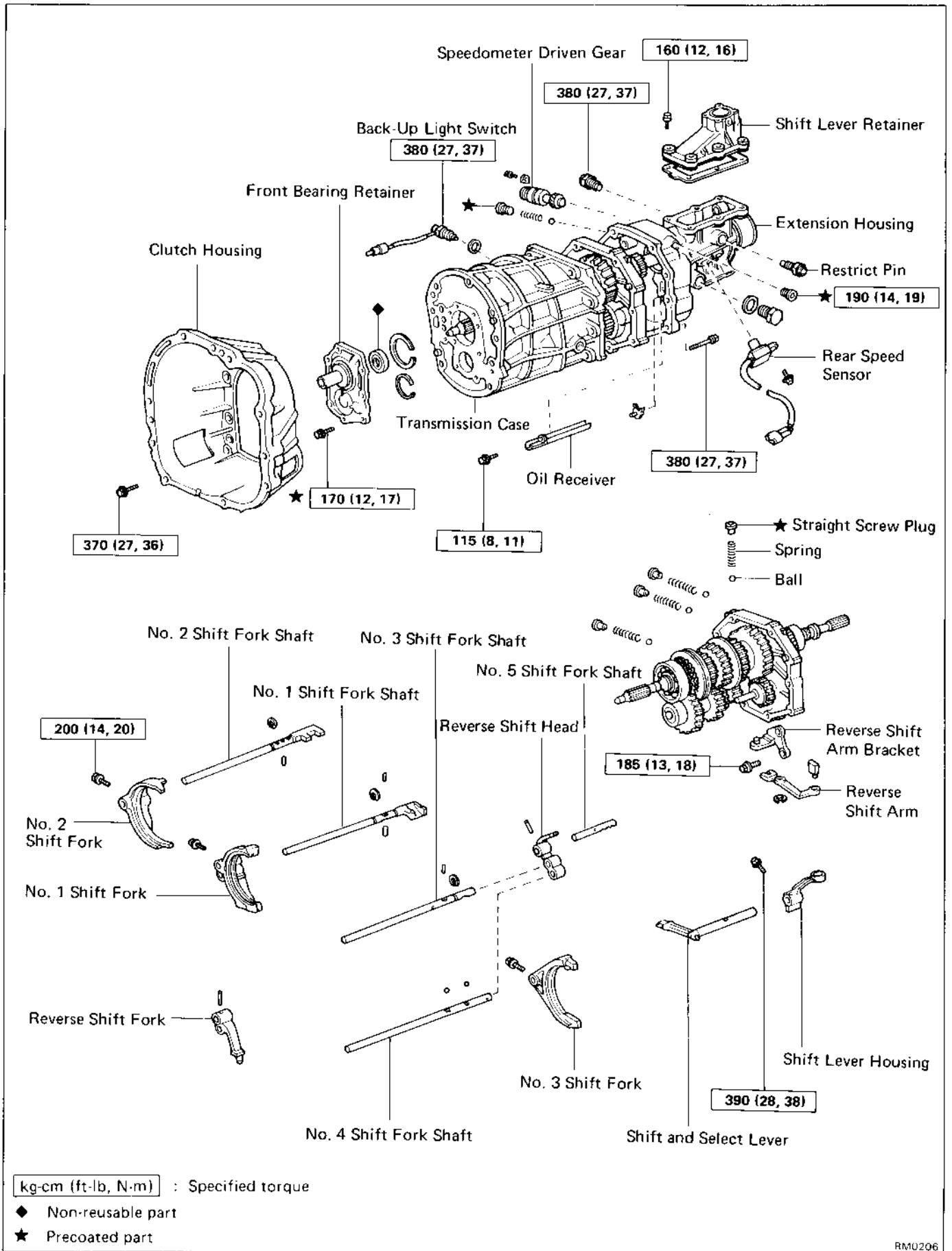

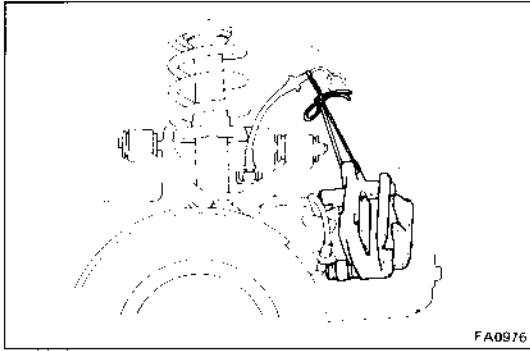

REPLACEMENT OF FRONT AXLE HUB BOLT

1. REMOVE DISC BRAKE CALIPER

- (a) Remove the brake hose bracket from the steering knuckle.
- (b) Remove the disc brake caliper from the steering and suspended it with wire.

2. REMOVE ROTOR DISC

Place matchmarks on the rotor disc and hub.

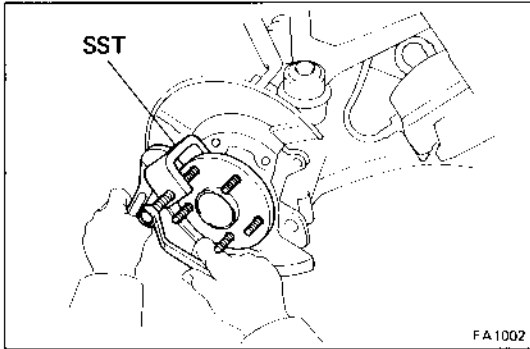

3. REMOVE FRONT AXLE HUB BOLT

- (a) Align the disc brake dust cover cutting portion and axle hub bolt.
- (b) Using SST, remove the axle hub bolt.

SST 09650-17011

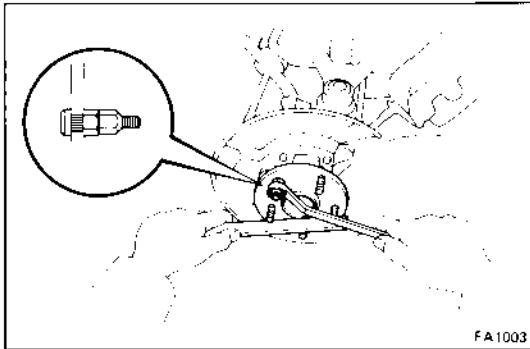

4. INSTALL FRONT AXLE HUB BOLT

Hold the front axle hub, and install a new hub bolt.

5. INSTALL ROTOR DISC

Align the matchmarks on the rotor disc.

6. MEASURE ROTOR DISC RUNOUT (See page BR-28)

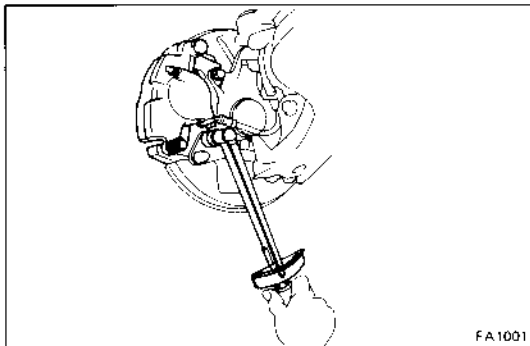

7. INSTALL DISC BRAKE CALIPER TO STEERING KNUCKLE

Torque: 1,065 kg-cm (77 ft-lb, 104 N·m)

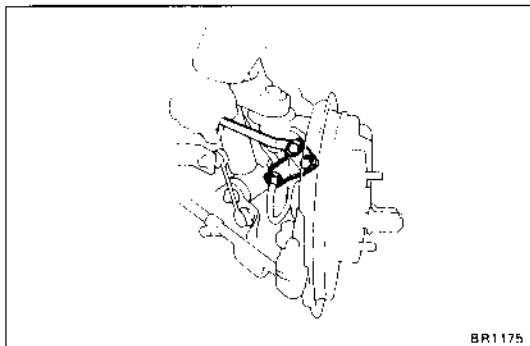

8. INSTALL BRAKE HOSE BRACKET TO STEERING KNUCKLE

Torque: 195 kg-cm (14 ft-lb, 19 N·m)

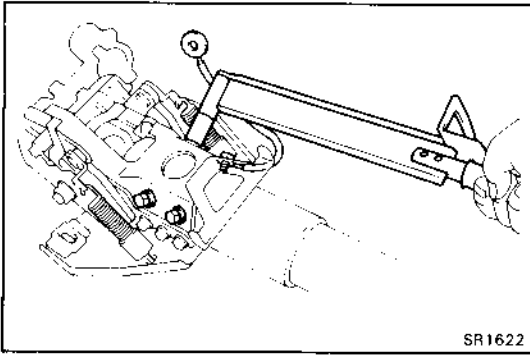

- 25. INSTALL COLUMN TUBE TO BREAKAWAY BRACKET**
- Install the column tube to the breakaway bracket.
 - Place the bond cable.
 - Install and torque the four bolts.
- Torque: 195 kg-cm (14 ft-lb, 19 N·m)**

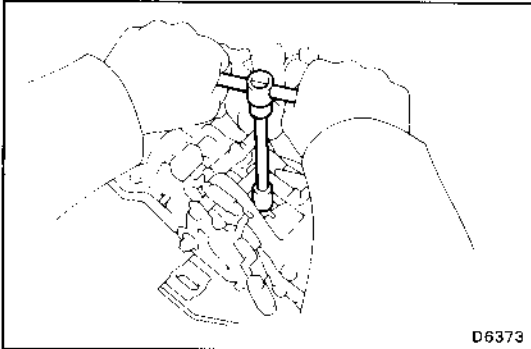

- 26. INSTALL INTERMEDIATE SHAFT TO COLUMN TUBE**
- Coat the O-ring of the thrust stopper with MP grease.
 - Install the intermediate shaft to the column tube.
 - Connect the universal joint of main shaft and intermediate shaft.
- Torque: 260 kg-cm (19 ft-lb, 25 N·m)**

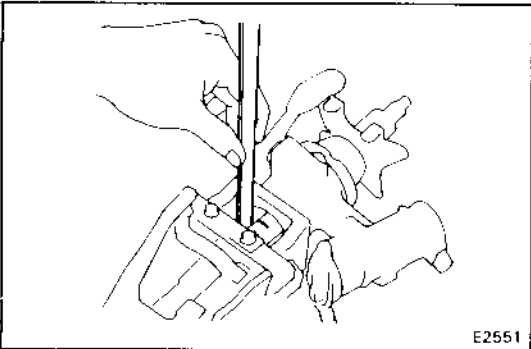

- Match the mark on the shaft accords with the upper bracket surface, as shown.

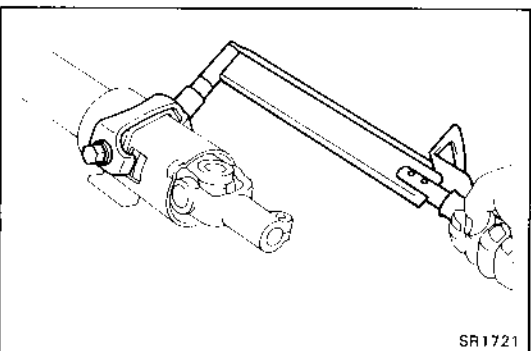

- Install the retainer bracket and two bolts.
 - Torque the two bolts.
- Torque: 280 kg-cm (20 ft-lb, 27 N·m)**

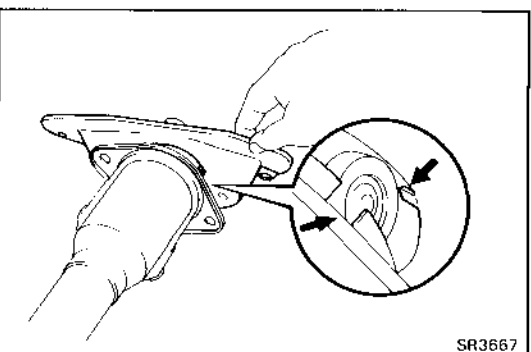

- 27. INSTALL COLUMN HOLE COVER**
- Install a new O-ring and cover plate to the column tube.
 - Align the cutout portion of the column tube to the protrusion of the hole cover, and install with the two bolts.
- Torque: 130 kg-cm (9 ft-lb, 13 N·m)**

- 28. INSTALL IGNITION KEY LIGHT WITH SCREW**

3**Check center airbag sensor assembly.**

Center Airbag Sensor Assembly Spiral Cable Steering Wheel Pad (Squib)

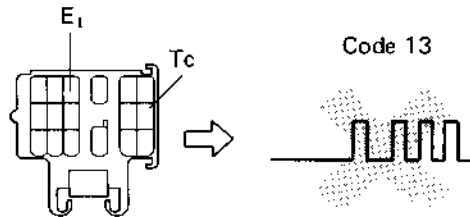
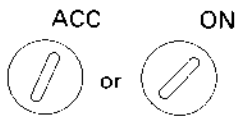
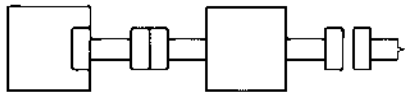
AB0074
AB0118 AB0119
SH-18.1 FI1390

- P** (1) Connect negative (–) terminal cable to battery.
(2) Clear malfunction code 41 stored in memory (See page AB-31).

- C** (1) Turn ignition switch LOCK, and wait at least 2 seconds.
(2) Turn ignition switch ACC or ON, and wait at least 20 seconds.
(3) Using SST, connect terminals Tc and E₁ of check connector.
SST 09843-18020
(4) Check diagnostic code.

OK Diagnostic code 13 is not output.

Hint Codes other than code 13 may be output at this time, but this is not relevant to this check.

OK**NG****Replace center airbag sensor assembly.****4****Check squib.**

Center Airbag Sensor Assembly Spiral Cable Steering Wheel Pad (Squib)

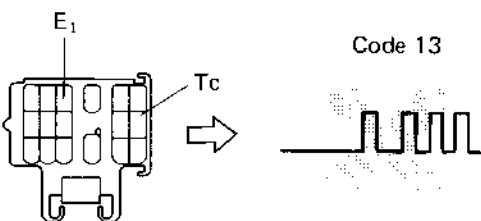
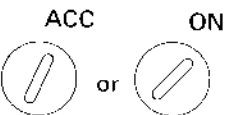
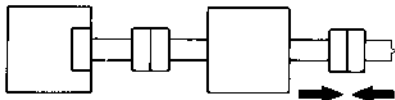
AB0075
AB0118 AB0119
SH-18.1 FI1390

- P** (1) Turn ignition switch LOCK.
(2) Disconnect battery negative (–) terminal cable, and wait at least 20 seconds.
(3) Connect steering wheel pad (squib) connector.
(4) Connect negative (–) terminal cable to battery.
(5) Clear malfunction code 41 stored in memory (See page AB-31).

- C** (1) Turn ignition switch LOCK, and wait at least 2 seconds.
(2) Turn ignition switch ACC or ON, and wait at least 20 seconds.
(3) Using SST, connect terminals Tc and E₁ of check connector.
SST 09843-18020
(4) Check diagnostic code.

OK Diagnostic code 13 is not output.

Hint Codes other than code 13 may be output at this time, but this is not relevant to this check.

OK**NG****Replace steering wheel pad.**

From the results of the above inspection, the malfunctioning part can now be considered normal. To make sure of this, use the simulation method to check.

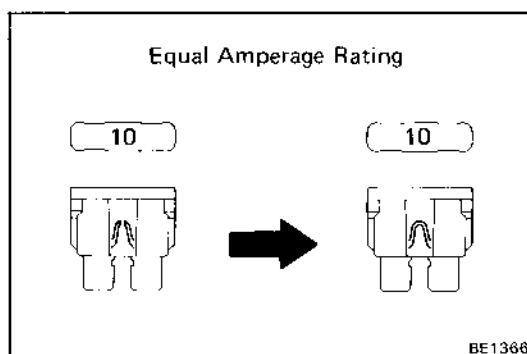
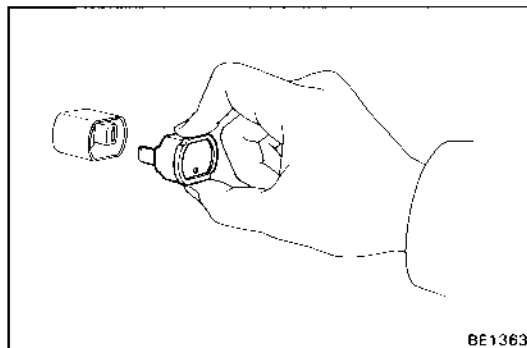
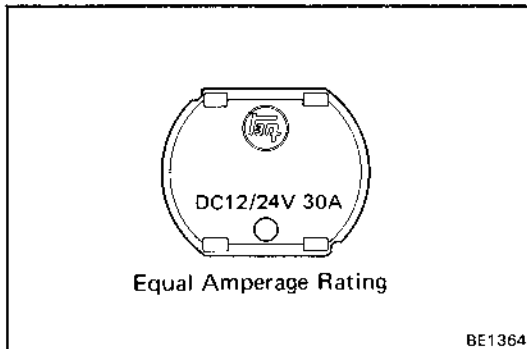
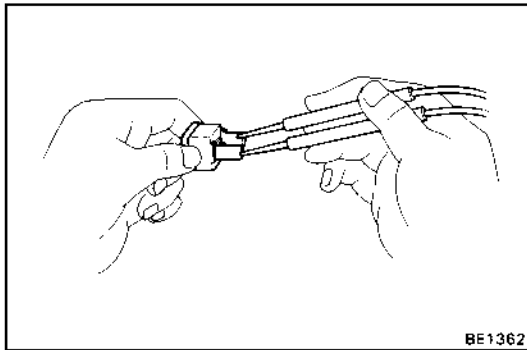
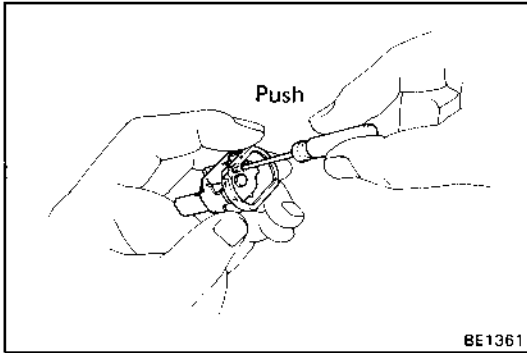

Reset Circuit Breaker

1. REMOVE CIRCUIT BREAKER

- (a) Disconnect the negative (—) cable from the battery.
- (b) Remove the circuit breaker.

2. RESET CIRCUIT BREAKER

- (a) Insert the needle into the reset hole and push it.
- (b) Using an ohmmeter, check that there is continuity between both terminals of the circuit breaker.

If continuity is not as specified, replace the circuit breaker.

HINT: If replacing the circuit breaker, be sure to replace it with a breaker with an equal amperage rating.

3. INSTALL CIRCUIT BREAKER

- (a) Install the circuit breaker.
- (b) Connect the negative (—) cable to the battery.

HINT: If a circuit breaker continues to cut out, a short circuit is indicated. Have the system checked by a qualified technician.

Replacement of Fuse and Fusible Link

HINT: If replacing the fuse or fusible link, be sure to replace it with a fuse or fusible link with an equal amperage rating.

Connector

Theft Deterrent Computer

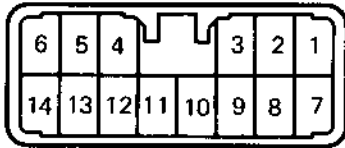

Ignition Switch

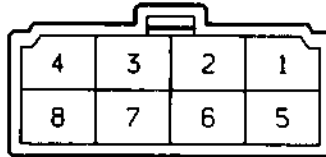

LH Front Door Key Lock and Unlock Switch

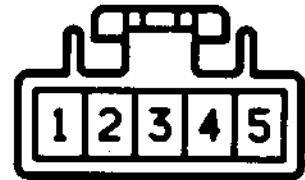

RH Front Door Key Lock and Unlock Switch



Back Door Key Unlock Switch

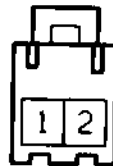

Door Lock Solenoid

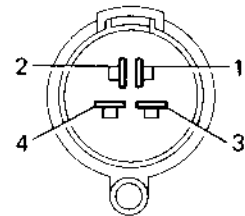

Back Door Courtesy Switch



Engine Hood Courtesy Switch

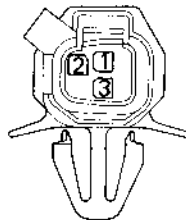

Light Retractor Control Relay

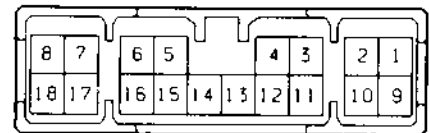

Theft Deterrent Horn

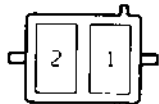

Starter Relay

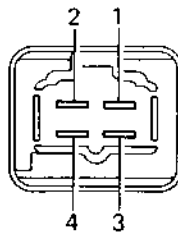

Door Lock Switch

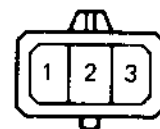

SYSTEM COMPONENTS

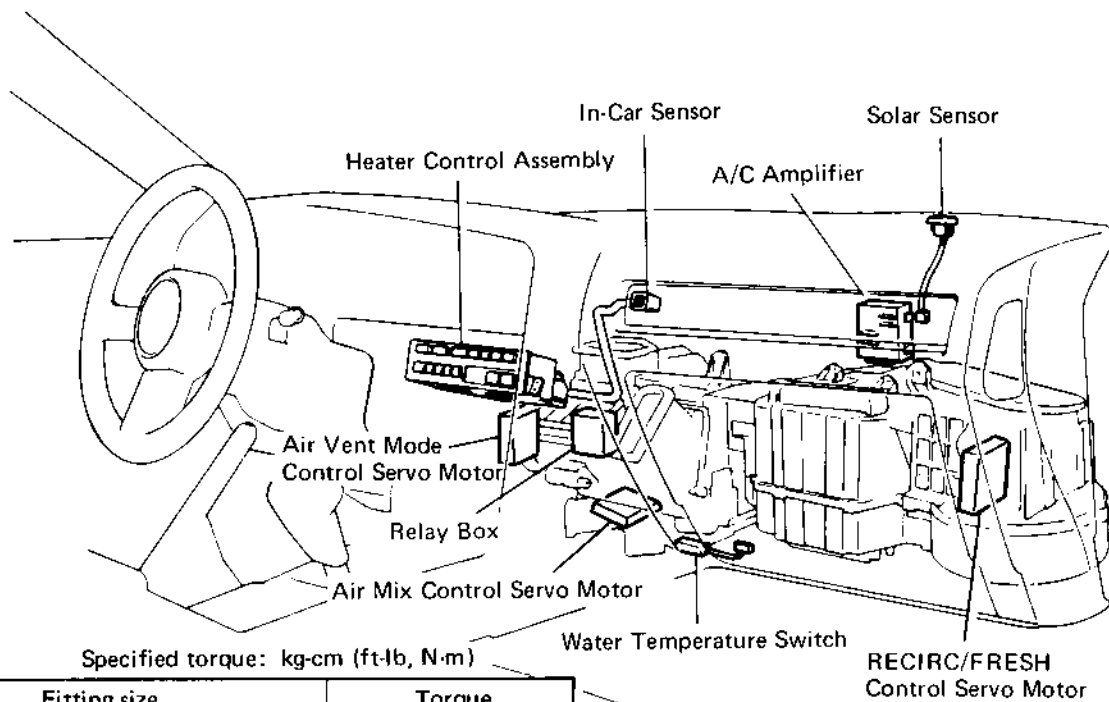
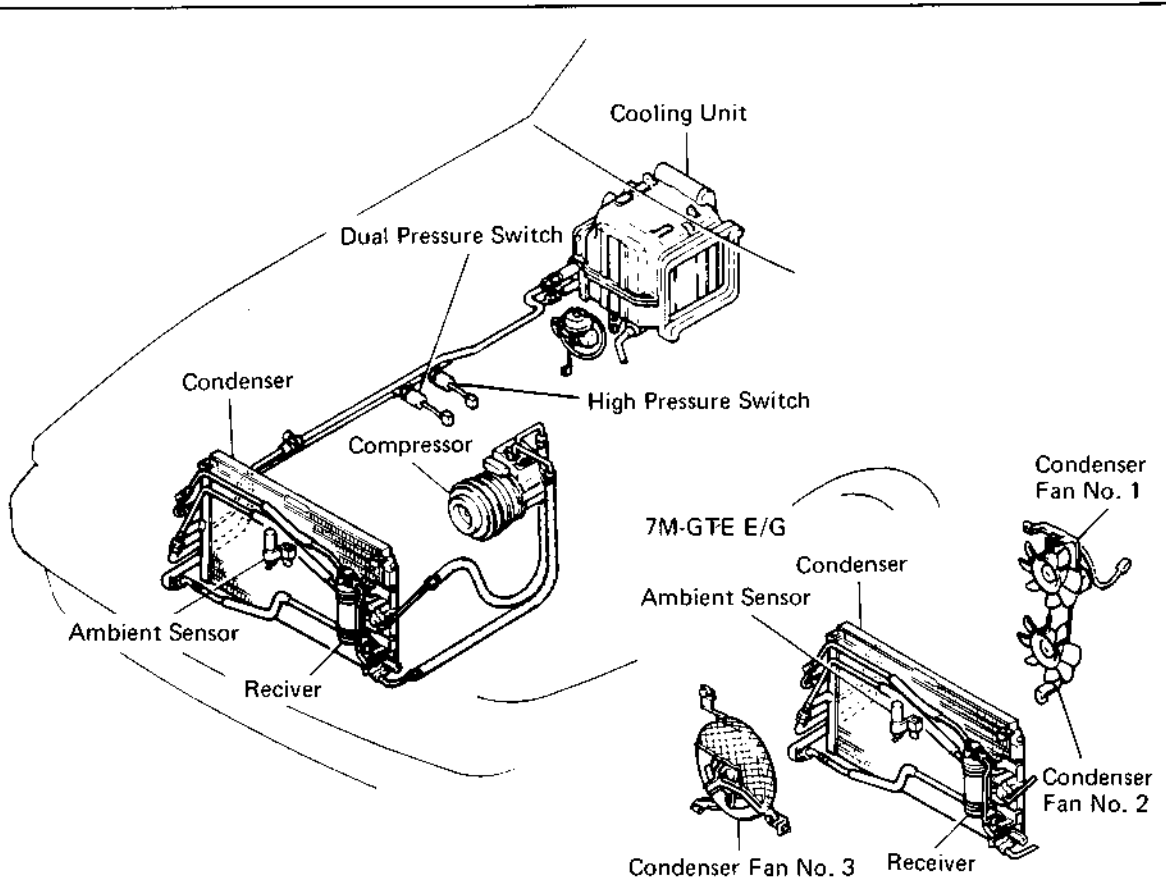









Specified torque: kg-cm (ft-lb, N-m)

Fitting size	Torque	
0.31 in. Tube	135 (10, 13)	
0.50 in. Tube	225 (16, 22)	
0.62 in. Tube	325 (24, 32)	
Bolted Type	(For Compressor)	250 (18, 25)
	(For Condenser)	250 (18, 25)

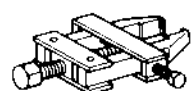
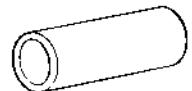
Specifications (Cont'd)

Bushing bore	Oil pump body	Limit	38.19 mm	1.5035 in.
	Stator shaft (FR)	Limit	21.58 mm	0.8496 in.
	(RR)	Limit	27.08 mm	1.0661 in.
	O/D direct clutch drum	Limit	27.11 mm	1.0673 in.
	O/D planetary gear	Limit	11.27 mm	0.4437 in.
	Direct clutch drum	Limit	53.99 mm	2.1256 in.
	Forward clutch drum	Limit	24.08 mm	0.9480 in.
	Front planetary ring gear	Limit	24.08 mm	0.9480 in.
	Planetary sun gear	Limit	27.08 mm	1.0661 in.
	Transmission case	Limit	38.19 mm	1.5035 in.
Extension housing	Limit	40.09 mm	1.5783 in.	
Flange thickness	O/D direct clutch (C ₀)	No. 21	3.1 mm	0.122 in.
		No. 20	3.2 mm	0.126 in.
		No. 19	3.3 mm	0.130 in.
		No. 18	3.4 mm	0.134 in.
		No. 17	3.5 mm	0.138 in.
		No. 16	3.6 mm	0.142 in.
	Direct clutch (C ₂)	No. 33	3.0 mm	0.118 in.
		No. 32	3.1 mm	0.122 in.
		No. 31	3.2 mm	0.126 in.
		No. 30	3.3 mm	0.130 in.
		No. 29	3.4 mm	0.134 in.
		No. 28	3.5 mm	0.138 in.
		No. 27	3.6 mm	0.142 in.
		No. 34	3.7 mm	0.146 in.
	O/D brake (B ₀)	No. 26	3.3 mm	0.130 in.
		No. 25	3.5 mm	0.138 in.
		No. 12	3.6 mm	0.142 in.
		No. 24	3.7 mm	0.146 in.
		No. 11	3.8 mm	0.150 in.
		No. 23	3.9 mm	0.154 in.
		None	4.0 mm	0.157 in.
First and Reverse Brake (B ₃)	No. 50	5.0 mm	0.197 in.	
	No. 51	4.8 mm	0.189 in.	
	No. 52	4.6 mm	0.181 in.	
	No. 53	4.4 mm	0.173 in.	
	No. 54	4.2 mm	0.165 in.	
	No. 55	4.0 mm	0.157 in.	
Clutch piston stroke	O/D direct clutch (C ₀)		1.85 – 2.15 mm	0.0738 – 0.0846 in.
	Direct clutch (C ₂)		1.37 – 1.60 mm	0.0539 – 0.0630 in.
	Forward clutch (C ₁)	7M-GE	3.42 – 3.93 mm	0.1346 – 0.1547 in.
		7M-GTE	3.73 – 4.59 mm	0.1469 – 0.1807 in.
Brake piston stroke	O/D brake (B ₀)	7M-GE	1.40 – 1.70 mm	0.0551 – 0.0669 in.
		7M-GTE	1.75 – 2.05 mm	0.0689 – 0.0807 in.
	Second coast brake (B ₁)		1.5 – 3.0 mm	0.059 – 0.118 in.
Brake pack clearance	Second brake (B ₂)		0.62 – 1.98 mm	0.0244 – 0.0780 in.
	First and reverse brake (B ₃)	7M-GE	0.60 – 1.12 mm	0.0236 – 0.0441 in.
		7M-GTE	0.70 – 1.22 mm	0.0276 – 0.0480 in.

SST (SPECIAL SERVICE TOOLS) (Cont'd)

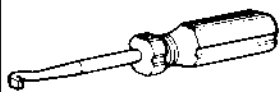
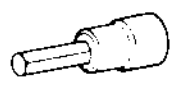
Section	Part Name	Part No.	Illustration	EM	TC	FI	CO	LU	ST	CH	CL	MT	AT	PR	FA	RA	BR	SR	AB	BE	BO
	Brake Tube Union Nut 10 x 12 mm Wrench	09751-36011									●						●				
	Windshield Moulding Remover	09806-30010																			●
	Door Hinge Set Bolt Wrench	09812-00010																			●
	Alternator Rear Bearing Puller	09820-00021								●											
	Alternator Rear Bearing Replacer	09820-00030								●											
	Alternator Pulley Set Nut Wrench Set	09820-63010								●											
	Wiring "A" EFI Inspection	09842-30050				●															
	Wiring "E" EFI Inspection	09842-30060				*1															
	Wiring "F" EFI Inspection	09842-30070				*2															
	Diagnosis Check Wiring	09843-18020											●						●		
	Spring Tension Tool	09921-00010										●	*3	●							
	Hexagon 14 mm Wrench	09923-00010		●																	

Remarks:

*1 7M-GTE only

*2 7M-GE only

*3 Speedometer driven gear oil seal

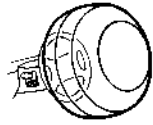

SRS Airbag

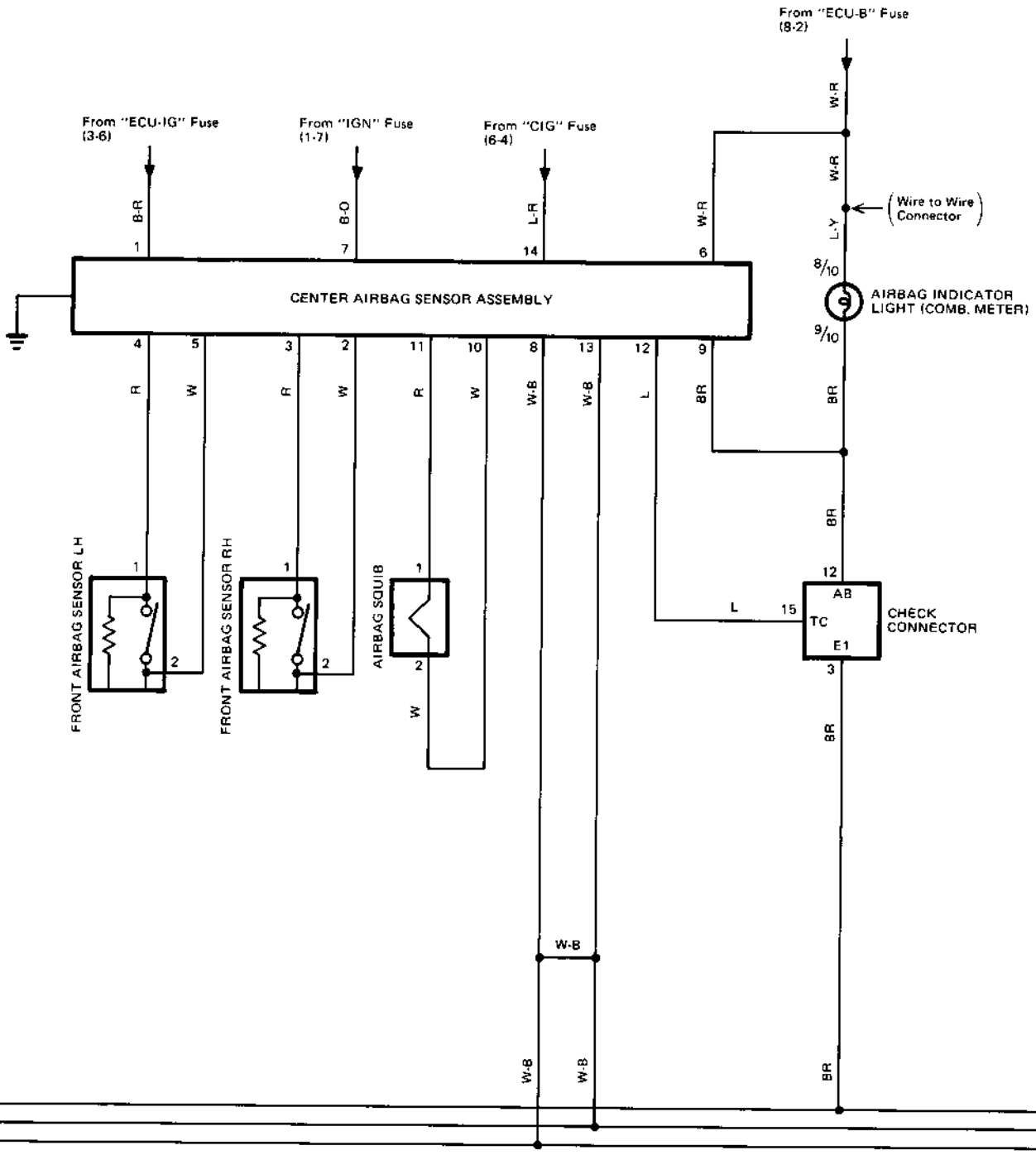

b = Located on engine block

c = Located under left front pillar

d = Located under right front pillar