

TRANSMISSION VALVE BODY ASSY (A761E) COMPONENTS

4007L-03

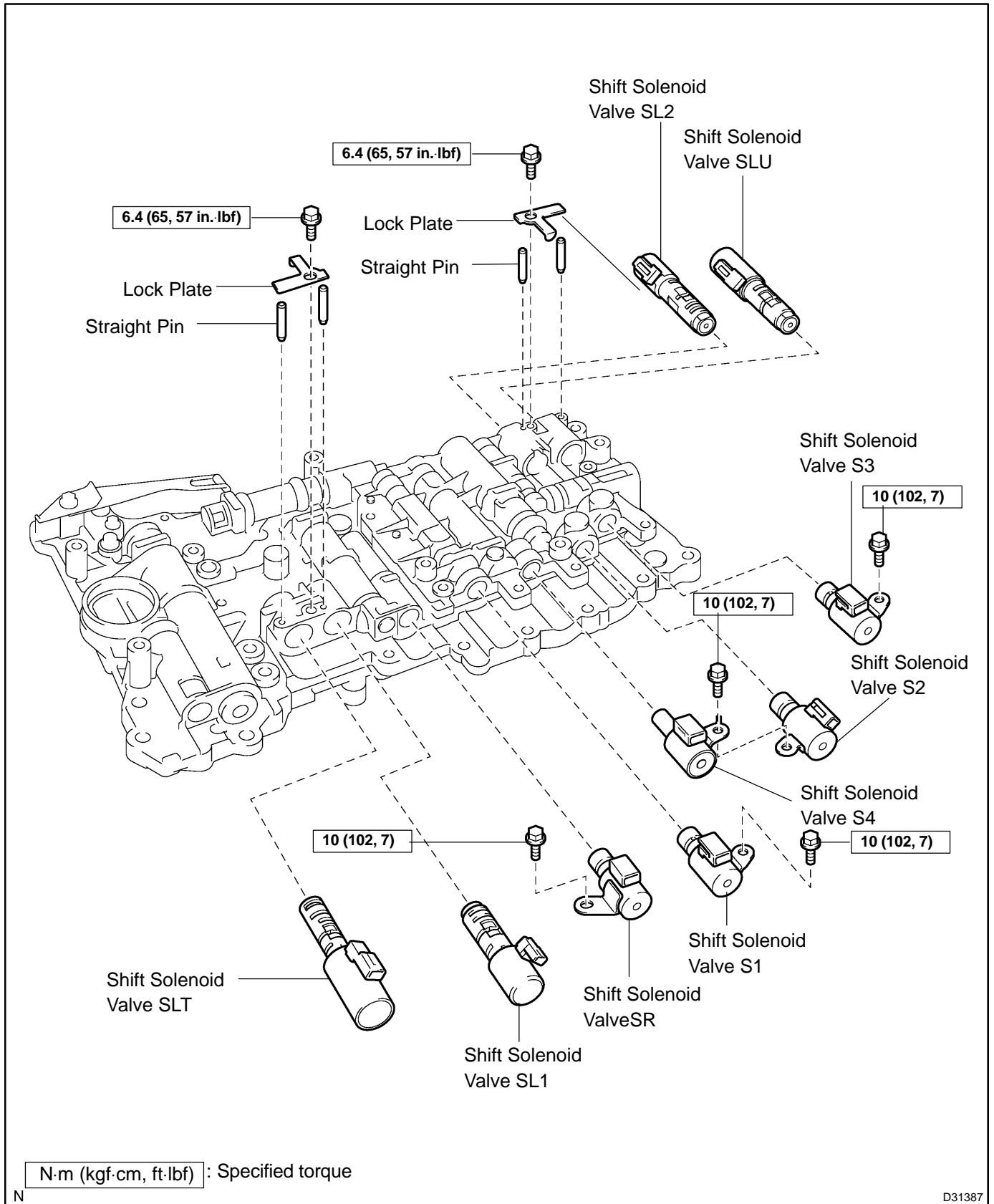

CLUTCH DRUM & INPUT SHAFT ASSY (A761E) COMPONENTS

40075-03

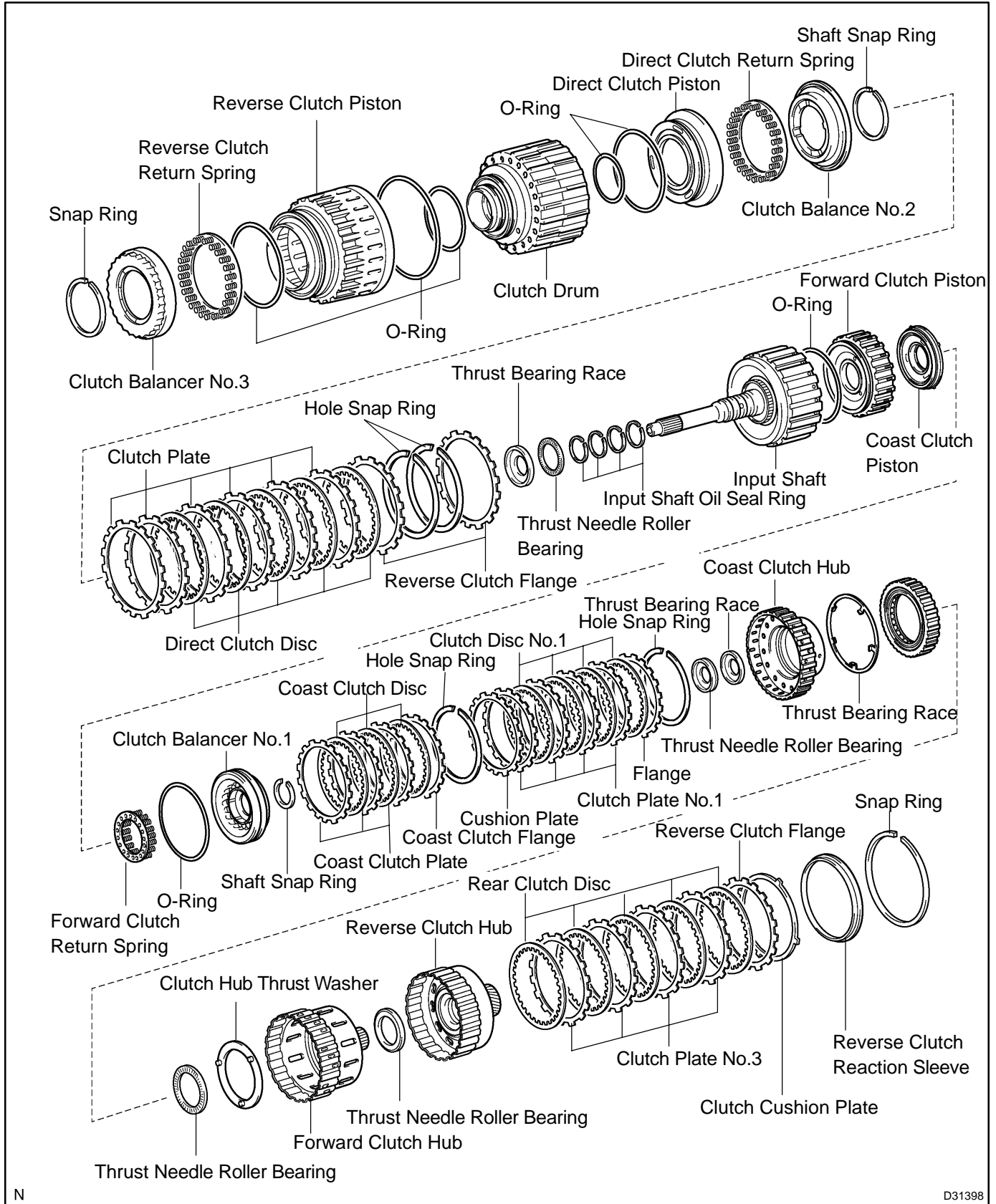





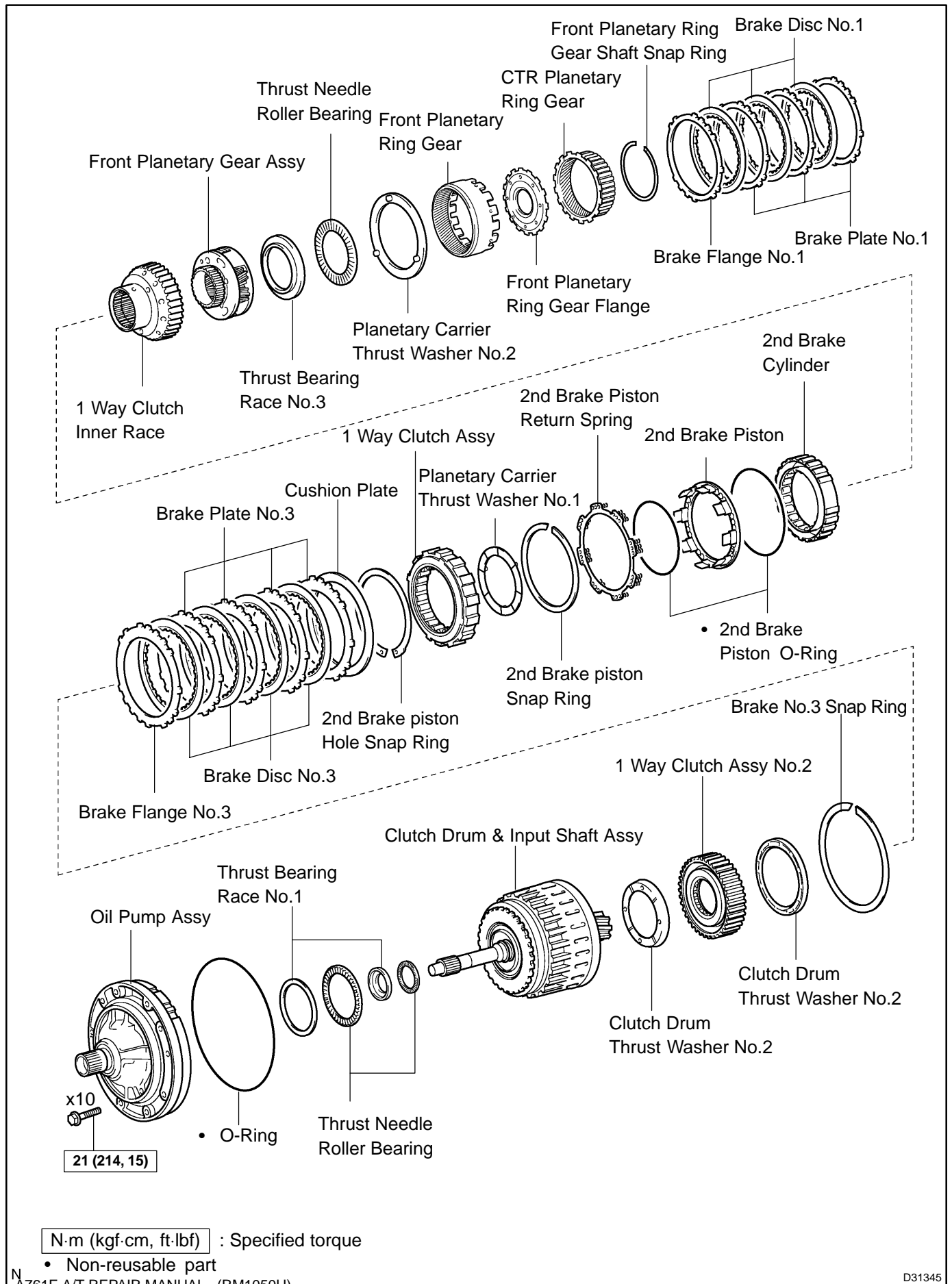

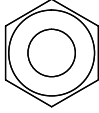
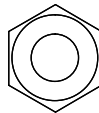
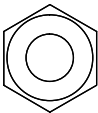
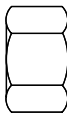

N

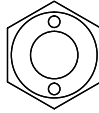
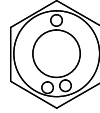
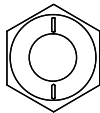
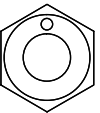
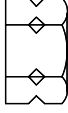
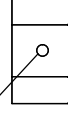
D31398

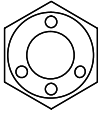
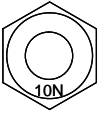
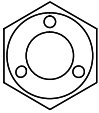
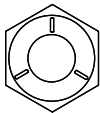
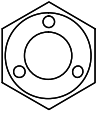

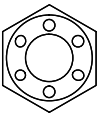
HOW TO DETERMINE NUT STRENGTH

Nut Type		Class	
Present Standard Hexagon Nut	Old Standard Hexagon Nut		
	Cold Forging Nut		Cutting Processed Nut
 No Mark			4N
 No Mark (w/ Washer)	 No Mark (w/ Washer)	 No Mark	5N (4T)
  			6N
	 	  *	7N (5T)
 			8N
 	 	 No Mark	10N (7T)
 			11N
 			12N

*: Nut with 1 or more marks on one side surface of the nut.

B06432

HINT:

Use the nut with the same number of the nut strength classification or the greater than the bolt strength classification number when tightening parts with a bolt and nut.

Example: Bolt = 4T

Nut = 4N or more

A761E A/T REPAIR MANUAL (RM1050U)

Piston return spring free length	STD	23.74 mm (0.935 in.)
	Min.	14.42 mm (0.5677 in.)
Flange thickness	Mark	
	0	0 mm (0 in.)
	2	0.2 mm (0.00787 in.)
	4	0.4 mm (0.01575 in.)
	6	0.6 mm (0.02362 in.)
	8	0.8 mm (0.03150 in.)
	10	0.6 mm (0.03937 in.)
	12	0.6 mm (0.04724 in.)
14	0.6 mm (0.05512 in.)	

NO.2 BRAKE		
Piston stroke		0.6 to 0.9 mm (0.024 to 0.035 in.)
Piston return spring free length	STD	22.66 mm (0.8921 in.)
	Min.	14.21 mm (0.5594 in.)
Flange thickness	Mark	
	0	2.0 mm (0.079 in.)
	1	2.1 mm (0.083 in.)
	2	2.2 mm (0.087 in.)
	3	2.3 mm (0.091 in.)
	4	2.4 mm (0.094 in.)
	5	2.5 mm (0.098 in.)
	6	2.6 mm (0.102 in.)
7	2.7 mm (0.106 in.)	

NO.1 BRAKE		
Piston stroke		0.42 to 0.72 mm (0.017 to 0.028 in.)
Flange thickness	Mark	
	0	2.0 mm (0.079 in.)
	1	2.2 mm (0.087 in.)
	2	2.4 mm (0.094 in.)
	3	2.6 mm (0.102 in.)

INTERMEDIATE SHAFT		
Intermediate shaft run out	Maximum	0.08 mm (0.003 in.)
Intermediate shaft diameter	STD A:	25.962 to 25.975 mm (1.022 to 1.023 in.)
	B:	25.962 to 25.975 mm (1.022 to 1.023 in.)
	C:	32.062 to 32.075 mm (1.262 to 1.263 in.)
	D:	32.062 to 32.075 mm (1.262 to 1.263 in.)
	Min A:	25.912 mm (1.020 in.)
	B:	25.912 mm (1.020 in.)
	C:	32.012 mm (1.260 in.)
	D:	32.012 mm (1.260 in.)

ACCUMULATOR		
Spring	Free length/Outer diameter mm (in.)	Color
B ₁	Inner	44.98 (1.7709) / 11.30 (0.445)
	Outer	46.36 (1.8252) / 17.10 (0.6732)
C ₂		63.14 (2.4858) / 16.0 (0.6299)
B ₃		64.5 (2.539) / 19.5 (0.768)
C ₃	inner	44.0 (1.732) / 14.0 (0.551)
	outer	76.65 (3.0178) / 20.10 (0.7913)

Recomended Tools

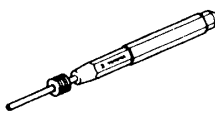
	09031-00030 Pin Punch	AUTOMATIC TRANSMISSION ASSY(A761E)
---	-----------------------	------------------------------------

SSM

	08826-00090 "Seal Packing 1281," THREE BOND 1281 or equivalent (FIPG)	AUTOMATIC TRANSMISSION ASSY(A761E)
--	---	------------------------------------

Equipment

Feeler gauge	
Cylinder Gauge	
Vernier calipers	
Dial indicator	
Micrometer	
Feeler gauge	
Straight edge	
Torque wrench	
Angle gauge	
V block	

Lubricant

Automatic transmission fluid Dry fill Drain and refill	8.5 liters (9.0 US qts, 7.5 Imp. qts) 2.3 liters (2.4 US qts, 2.0 Imp. qts)	ATF TYPE WS or equivalent
--	--	---------------------------

SSM (Special Service Materials)

	08826-00090 "Seal Packing 1281," THREE BOND 1281 or equivalent (FIPG)	AUTOMATIC TRANSMISSION ASSY(A750E/A750F)
--	---	--

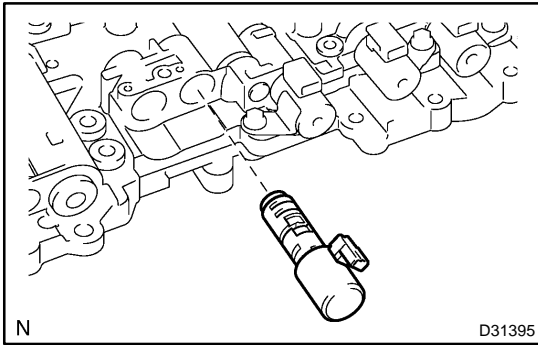
**5. REMOVE SHIFT SOLENOID VALVE SL1**

- (a) Remove shift solenoid valve SL1.

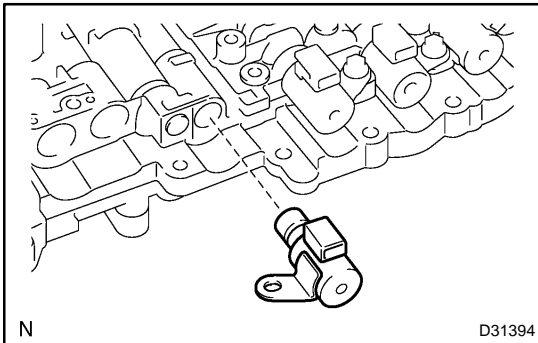
**6. REMOVE SHIFT SOLENOID VALVE SR**

- (a) Remove the shift solenoid valve SR.

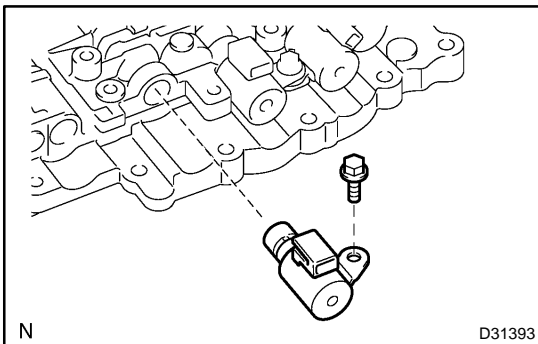
**7. REMOVE SHIFT SOLENOID VALVE S1**

- (a) Remove the bolt and the shift solenoid valve S1.

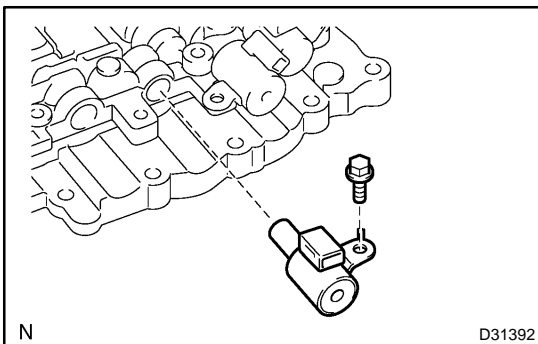
**8. REMOVE SHIFT SOLENOID VALVE S4**

- (a) Remove the bolt and the shift solenoid valve S4.

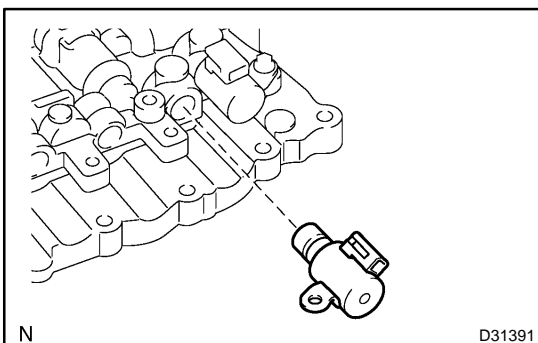
**9. REMOVE SHIFT SOLENOID VALVE S2**

- (a) Remove the shift solenoid valve S2.

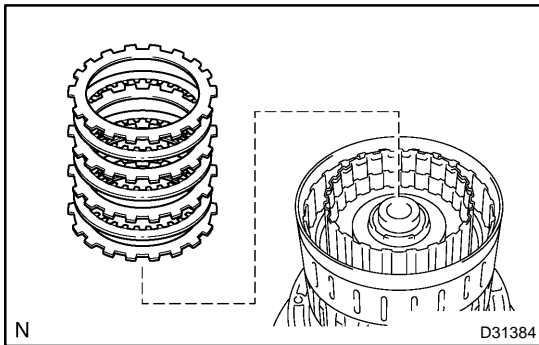

- (b) Remove the flange, the 3 discs and the 3 plates from the input shaft assy.

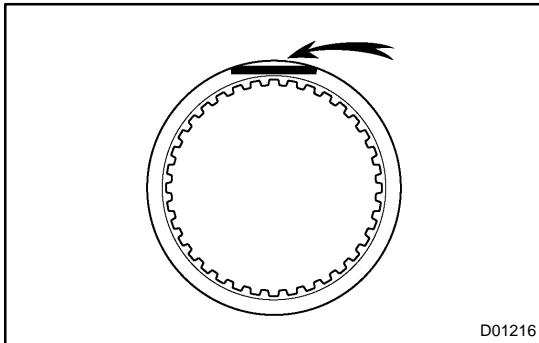

15. INSPECT COAST CLUTCH DISC

- (a) Check whether the sliding surface of the disc, the plate and the flange are worn or burnt. If necessary, replace them.

NOTICE:

- If the lining of the disc is peeled off or discolored, or even if only a part of the printed numbers is damaged, replace all discs.
- Before assembling new discs, soak them in ATF for at least 15 minutes.

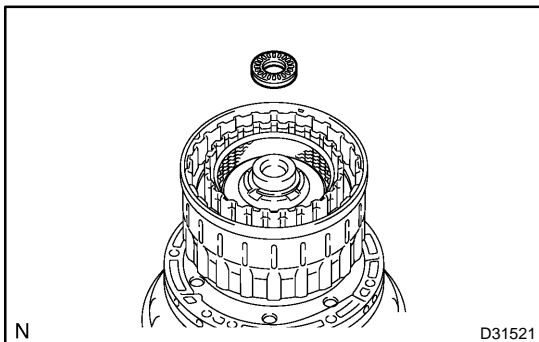

16. REMOVE INPUT SHAFT ASSY

- (a) Remove the thrust needle roller bearing from the input shaft assy.

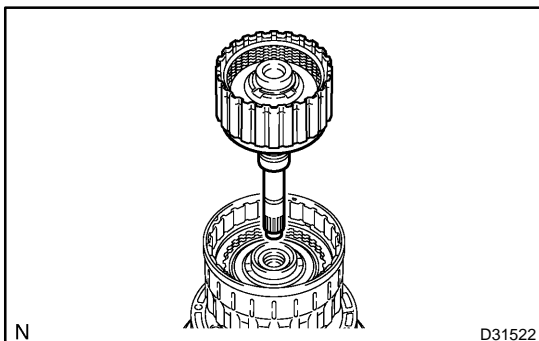

- (b) Remove the input shaft assy from the clutch drum assy.

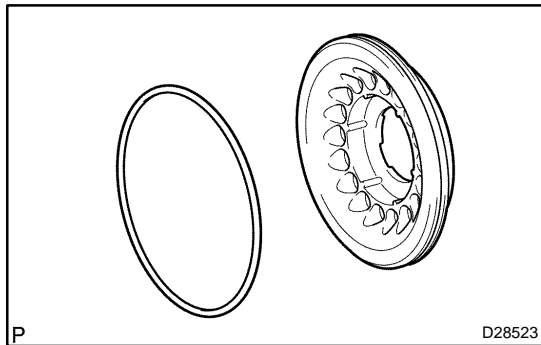
**41. INSTALL CLUTCH BALANCER NO.1**

- (a) Coat a new O-ring with ATF and install it on the clutch balancer No.1.

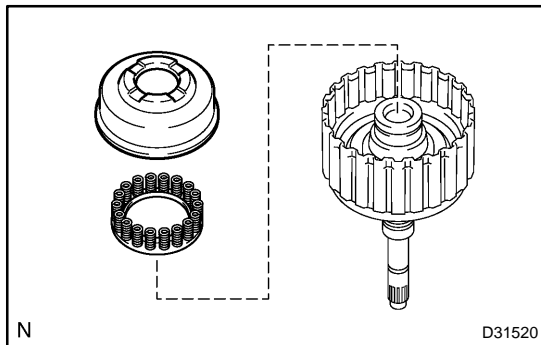

- (b) Install the clutch balancer No.1 and the forward clutch return spring sub assy.

NOTICE:

Be careful not to damage the O-ring.

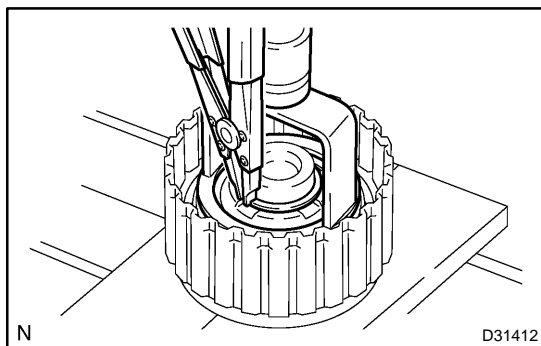

- (c) Place SST on the clutch balancer No.1, and compress the return spring with a press.

SST 09350-30020 (09350-07040, 09350-07070)

- (d) Install the snap ring with a snap ring expander.

NOTICE:

- **Be sure that the end gap of the snap ring is not aligned with the spring retainer claw.**
- **Stop pressing when the spring sheet is lowered to the place 1 to 2 mm (0.039 to 0.078 in.) from the snap ring groove to prevent the spring sheet from being deformed.**
- **Do not expand the snap ring excessively.**

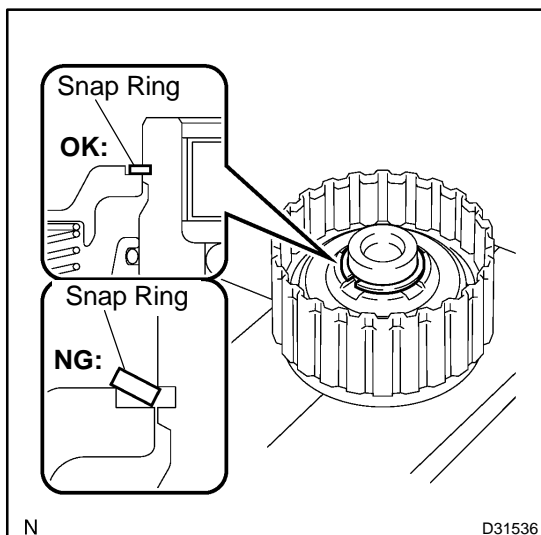

- (e) Set the end gap of the snap ring in the piston as shown in the illustration.

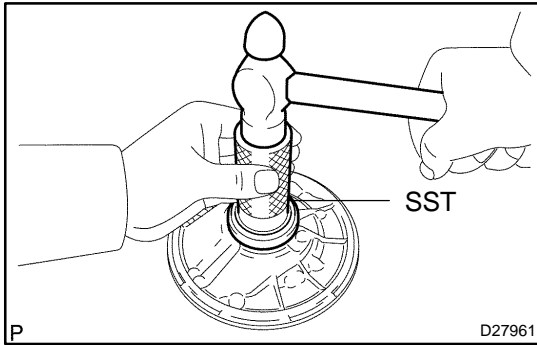
**12. INSTALL FRONT OIL PUMP OIL SEAL**

- (a) Using SST and a hammer, install a new oil seal.

HINT:

The oil seal end should be flush with the outer edge of the pump body.

SST 09350-30020 (09351-32140)

- (b) Coat the oil seal lip with MP grease.

13. FIX FRONT OIL PUMP BODY SUB-ASSY

- (a) Place the oil pump body on the torque converter clutch.

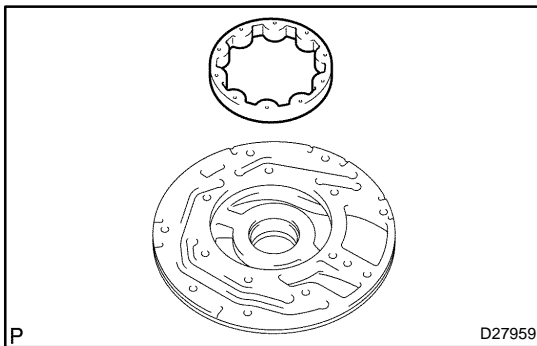
**14. INSTALL FRONT OIL PUMP DRIVEN GEAR**

- (a) Coat the driven gear with ATF.
(b) Install the driven gear to the oil pump body.

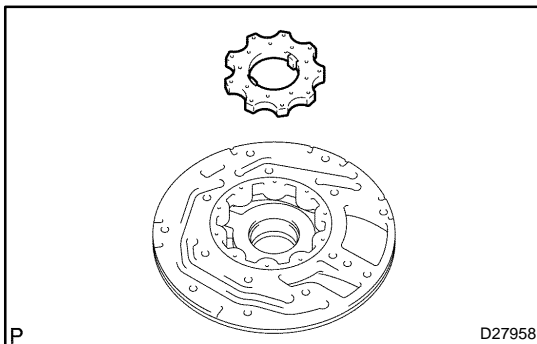
**15. INSTALL FRONT OIL PUMP DRIVE GEAR**

- (a) Coat the drive gear with ATF.
(b) Install the drive gear to the oil pump body.

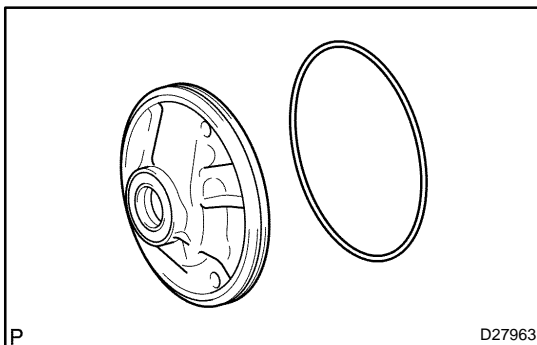
**16. INSTALL FRONT OIL PUMP BODY O-RING**

- (a) Install the O-ring to the oil pump body.

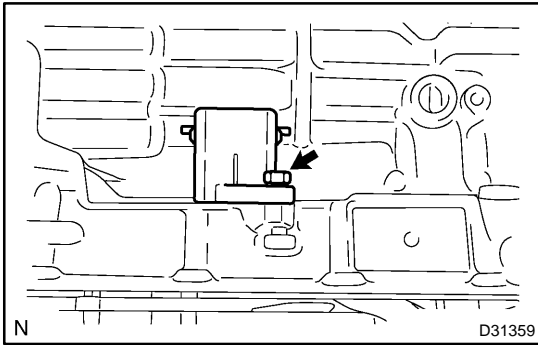

- (d) Remove the bolt from the case.
- (e) Pull the transmission wire out of the transmission case.
- (f) Remove the O-ring from the transmission wire.

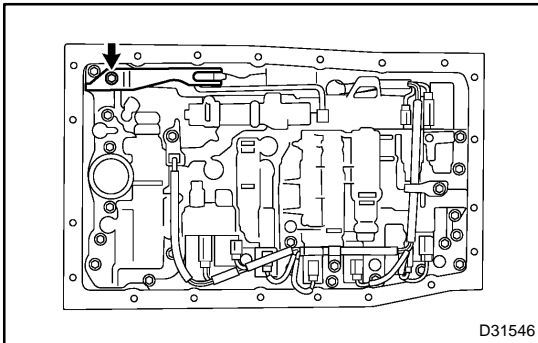

17. REMOVE TRANSMISSION VALVE BODY ASSY

- (a) Remove the bolt and detente spring.

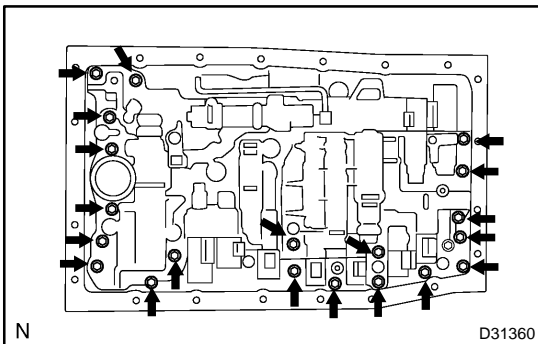

- (b) Remove the 20 bolts.
- (c) Remove the valve body assy.

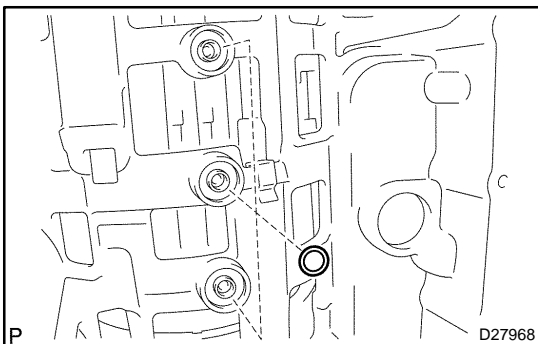

18. REMOVE TRANSAXLE CASE GASKET

- (a) Remove the 3 transaxle case gaskets.

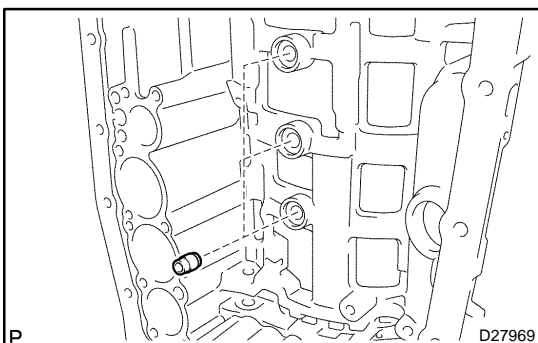

19. REMOVE BRAKE DRUM GASKET

- (a) Remove the 3 brake drum gaskets.

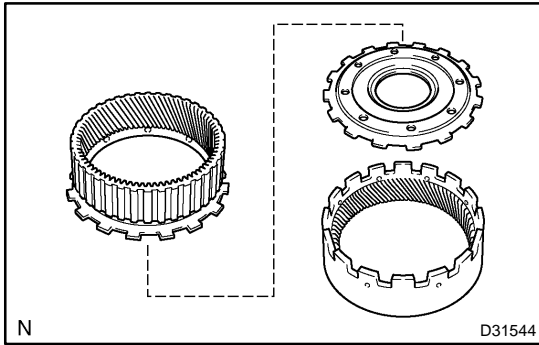

- (b) Remove the CTR planetary ring gear and the front planetary ring gear flange from the front planetary ring gear.

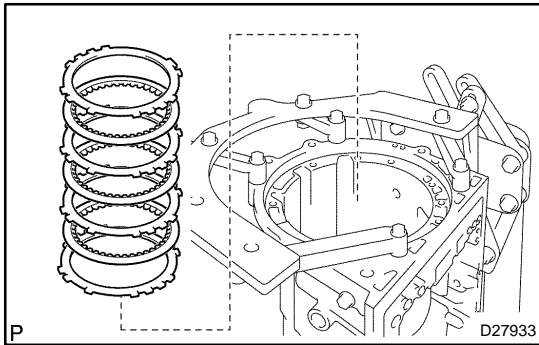

47. REMOVE BRAKE DISC NO.1

- (a) Remove the flange, the 3 discs and the 3 plates from the case.

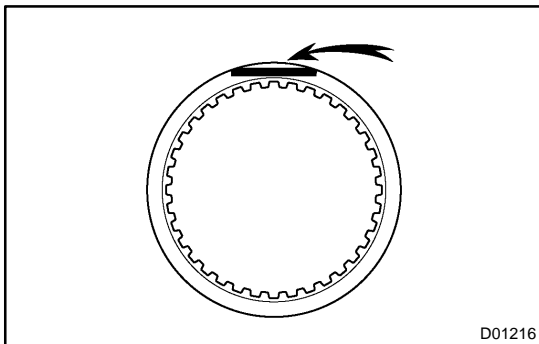

48. INSPECT BRAKE DISC NO.1

- (a) Check whether the sliding surface of the disc, the plate or the flange are worn or burnt.
If necessary, replace them.

NOTICE:

- If the lining of the disc is peeled off or discolored, or if any part of the groove is damaged, replace all discs.
- Before assembling new discs, soak them in ATF for at least 15 minutes.

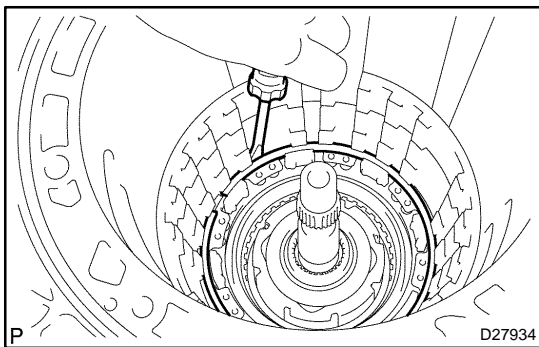

49. REMOVE BRAKE PISTON RETURN SPRING SNAP RING

- (a) Using a screwdriver, remove the brake piston return spring snap ring from the case.

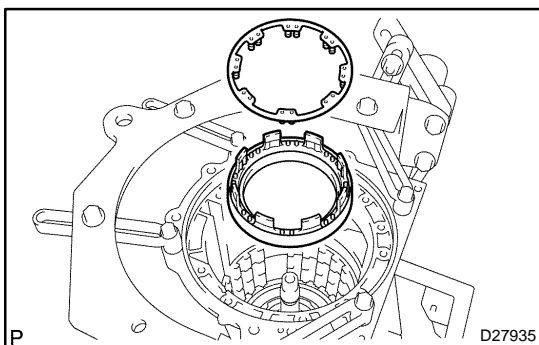

50. REMOVE BRAKE PISTON RETURN SPRING SUB-ASSY

- (a) Remove the brake piston return spring and the brake piston No.1 with the brake cylinder No.1 from the transmission case.

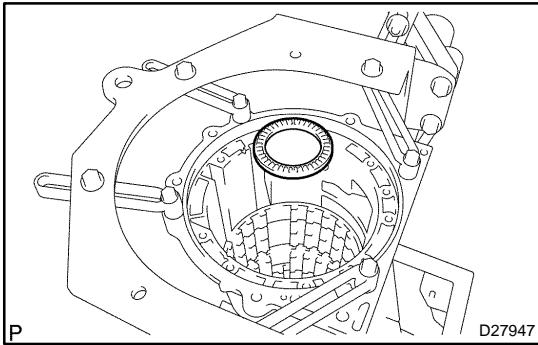

- (c) Remove the thrust needle roller bearing from the case.

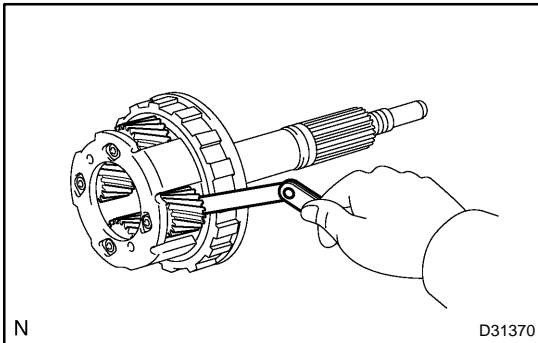

69. INSPECT REAR PLANETARY GEAR ASSY

- (a) Using a feeler gauge, measure the rear planetary gear pinion thrust clearance.

Standard clearance: 0.2 to 0.6 mm (0.008 to 0.024 in.)

Maximum clearance: 0.65 mm (0.026 in.)

If the clearance is greater than the maximum clearance, replace the planetary gear assy.

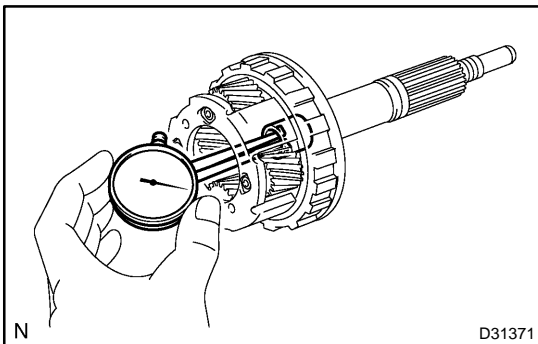

- (b) Using a dial indicator, measure the inside diameter of the rear planetary gear bushing.

Maximum inside diameter: 20.075 mm (0.790 in.)

If the inside diameter is greater than the maximum inside diameter, replace the rear planetary gear assy.

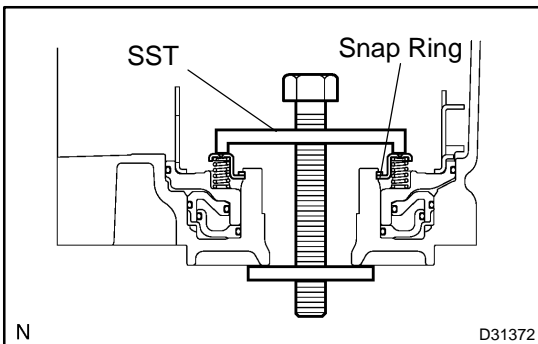

70. REMOVE 1ST & REVERSE BRAKE RETURN SPRING SUB-ASSY

- (a) Place SST on the 1st & reverse brake return spring sub-assy and compress the brake return spring.

SST 09350-30020 (09350-07050)

- (b) Using SST, remove the snap ring and the brake return spring.

SST 09350-30020 (09350-07070)

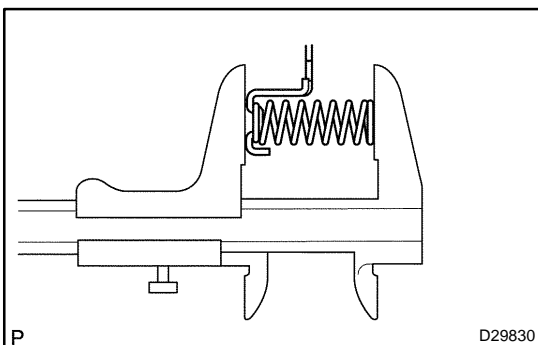

71. INSPECT 1ST & REVERSE BRAKE RETURN SPRING SUB-ASSY

- (a) Using a vernier calipers, measure the free length of the spring together with the spring seat.

Standard free length: 23.74 mm (0.935 in.)

Minimum free length: 14.42 mm (0.5677 in.)

If the inside diameter is shorter than the minimum free length, replace the brake piston return spring sub-assy.

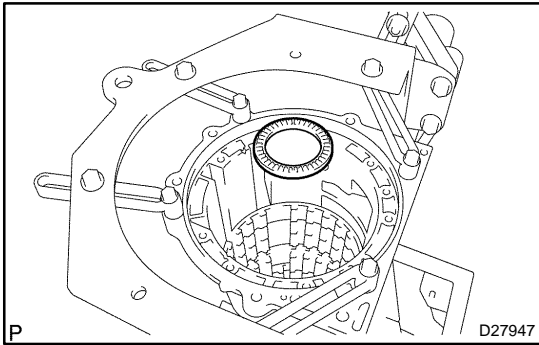

80. INSTALL REAR PLANETARY GEAR ASSY

(a) Install the thrust needle roller bearing.

Thrust needle roller bearing diameter:

	Inside	Outside
Thrust needle roller bearing	45.9 mm (1.807 in.)	64.0 mm (2.520 in.)

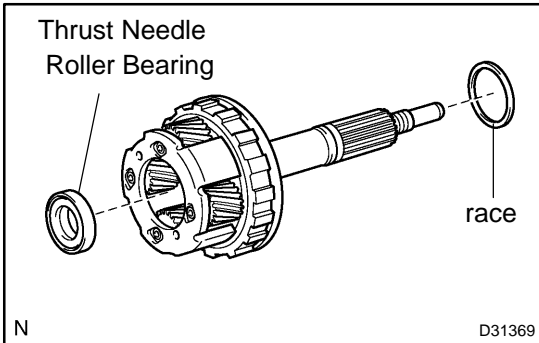

(b) Install the thrust needle roller bearing.

(c) Coat the thrust bearing race No.9 with petroleum jelly, and install it onto the rear planetary ring gear.

Bearing & race diameter:

	Inside	Outside
Bearing	21.5 mm (0.847 in.)	40.8 mm (1.606 in.)
Race	48.5 mm (1.909 in.)	62.7 mm (2.469 in.)

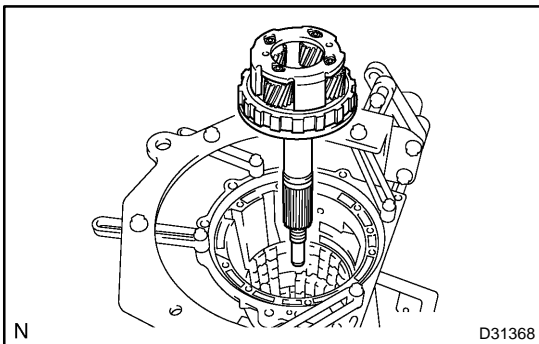

(d) Install the rear planetary gear assy.

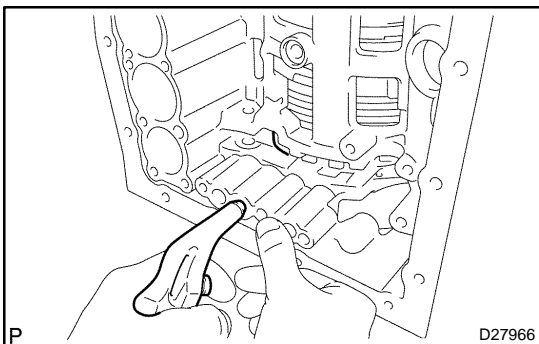

81. INSPECT PACK CLEARANCE OF FIRST & REVERSE BRAKE

(a) Make sure that the 1st & reverse brake piston move smoothly when pulling and releasing the compressed air gun lever while applying compressed air into the transmission case.

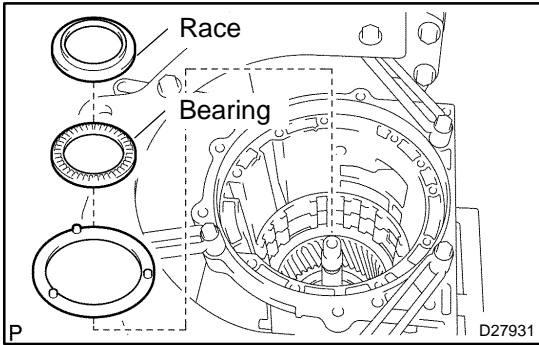

96. INSTALL FRONT PLANETARY GEAR ASSY

- (a) Install the thrust needle roller bearing and the thrust washer.
- (b) Coat the thrust race with petroleum jelly, and install it onto the front planetary ring gear.

Thrust needle roller bearing and race diameter:

	Inside	Outside
Bearing	43.4 mm (1.709 in.)	58.3 mm (2.295 in.)
Race	38.0 mm (1.496 in.)	57.0 mm (2.244 in.)

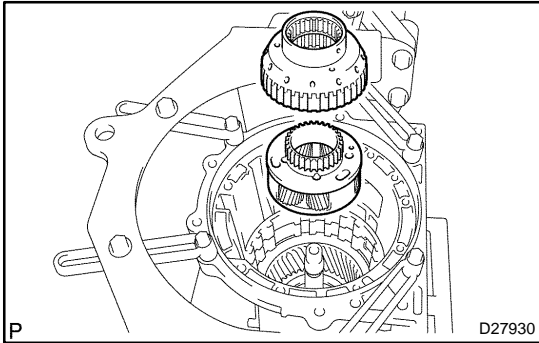

- (c) Install the front planetary gear assy and the 1 way clutch inner race to the case.

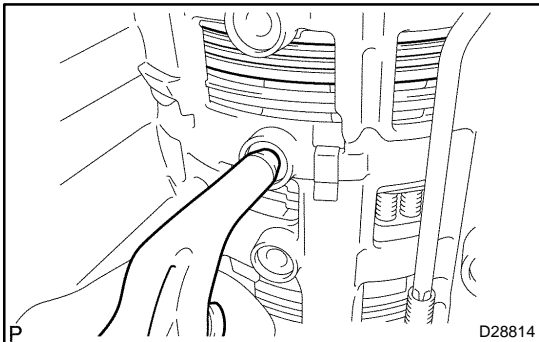

97. INSPECT PISTON STROKE OF BRAKE PISTON NO.1

- (a) Make sure the brake piston No.1 moves smoothly when pulling and releasing the compressed air gun lever while applying compressed air into the transmission case.