

CONTENTS

Generalities **A-1 → 6**

General data **B-1 → 6**

- General features B1-2 → 3
 - Engine cooling system B2-1 → 1
 - Engine lubrication system B3-1 → 1
 - Standard tightening torques B4-1 → 1
 - Specific tightening torques B5-1 → 31
 - Dimensions and tolerances B6-1 → 24
-

Tools **C-1 → 13**

Consumable products **D-1 → 2**

Stripping and mounting on stand **E-1 → 8**

- Handling E1-2 → 2
 - Drive belt(s) E2-1 → 2
 - Stand 1000 E3-1 → 6
 - Exhaust manifold E4-1 → 2
 - Oil remover (CCCV) E5-1 → 2
 - Air compressor E6-1 → 1
 - Steering pump E7-1 → 1
 - Starter E8-1 → 1
-

Cylinder head **F-1 → 4**

- Camshaft F1-2 → 11
 - Rocker arms F2-1 → 5
 - Fuel injectors F3-1 → 4
 - Cylinder head F4-1 → 22
-

Valve timing **G-1 → 8**

Reciprocating gear **H-1 → 28**





Engine cooling **I-1 → 4**

Lubrication **J-1 → 12**











Turbocharger **K-1 → 4**

Conventional symbols









Fitting

	Tighten to torque (Nm) (left-hand thread)		Tighten by indicated value
	Tighten to torque (Nm) (right-hand thread)		Loosen by indicated value
	Tightening torque with lubricated threaded hardware		

Dimensioning

	Tightening		... Greater than or equal to ...
	Equal to		Wear limit
	... Less than ...		Machining limit or dimension
	... Greater than ...		Maximum out-of-true
	... Less than or equal to ...		Maximum parallelism error

Repair

	Force to be exerted in the direction shown (hammer - press)		Smear or coat (see "Consumables" table)
	Heat or cool: Temperature in degrees Celsius (e.g. + 80 °C)		Fill to level (see "Technical Data" and "Consumables" table)
	Weld bead		Grease or oil (see "Consumables" table)
	Repair time - Heating time		Mark - Assemble according to marking

Engine horsepower and torque

Type designation	Maximum horsepower	Maximum torque
DXi 11 330	243 kW at 1900 rpm	1650 Nm at 1150 rpm
DXi 11 370	272 kW at 1900 rpm	1795 Nm at 1150 rpm
DXi 11 380	280 kW at 1900 rpm	1800 Nm at 1150 rpm
DXi 11 410	302 kW at 1900 rpm	1950 Nm at 1150 rpm
DXi 11 440	324 kW at 1900 rpm	2000 Nm at 1150 rpm
DXi 11 450	332 kW at 1900 rpm	2150 Nm at 1150 rpm

Technical data

Number of cylinders	6
Bore	123 mm
Stroke	152 mm
Displacement	10836 cm³
Compression ratio	18.3/1
n°1 cylinder:	end opposite flywheel
Direction of rotation of engine:	anticlockwise seen from flywheel end
Firing order	1.5.3.6.2.4
Idling speed	590 → 650 rpm
Max. no-load speed	2200 rpm
Max. full load speed	2200 rpm
Fuel:	diesel fuel
Supercharged:	by turbocharger with intercooler
Engine weight including accessories	1010 kg

Intake manifold

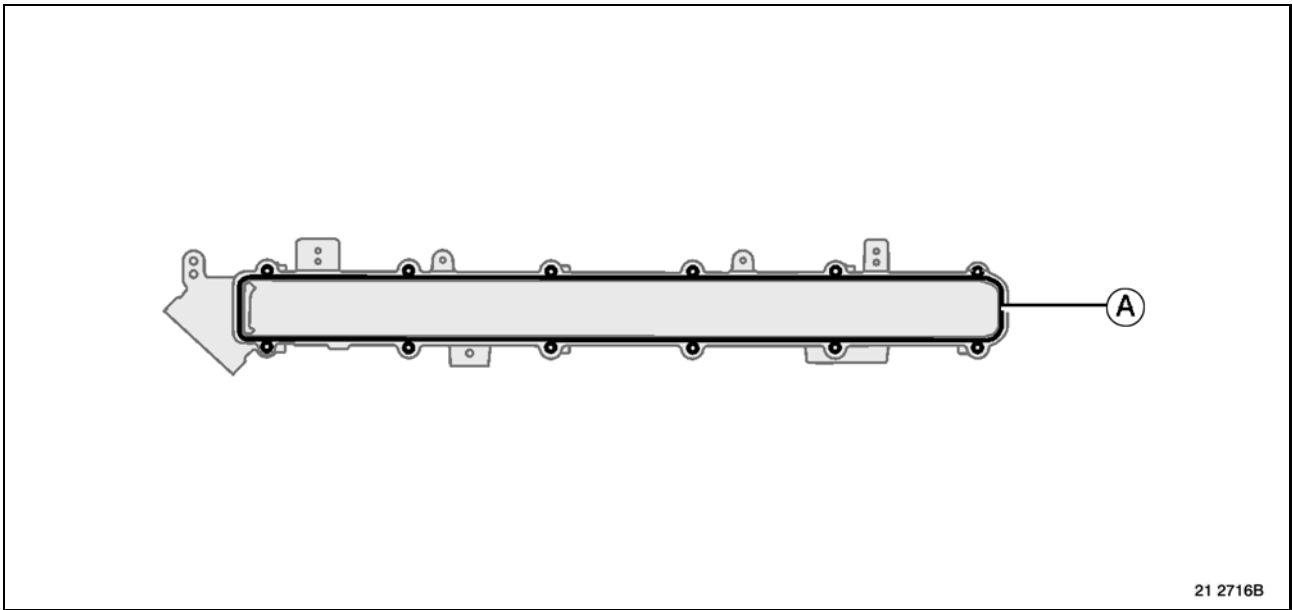

Apply a bead of silicone **dia. 2 mm (A)** as shown in the drawing. Perform assembly within 20 minutes of application of the silicone.

Apply "**SILICONE 7091**" sealant.

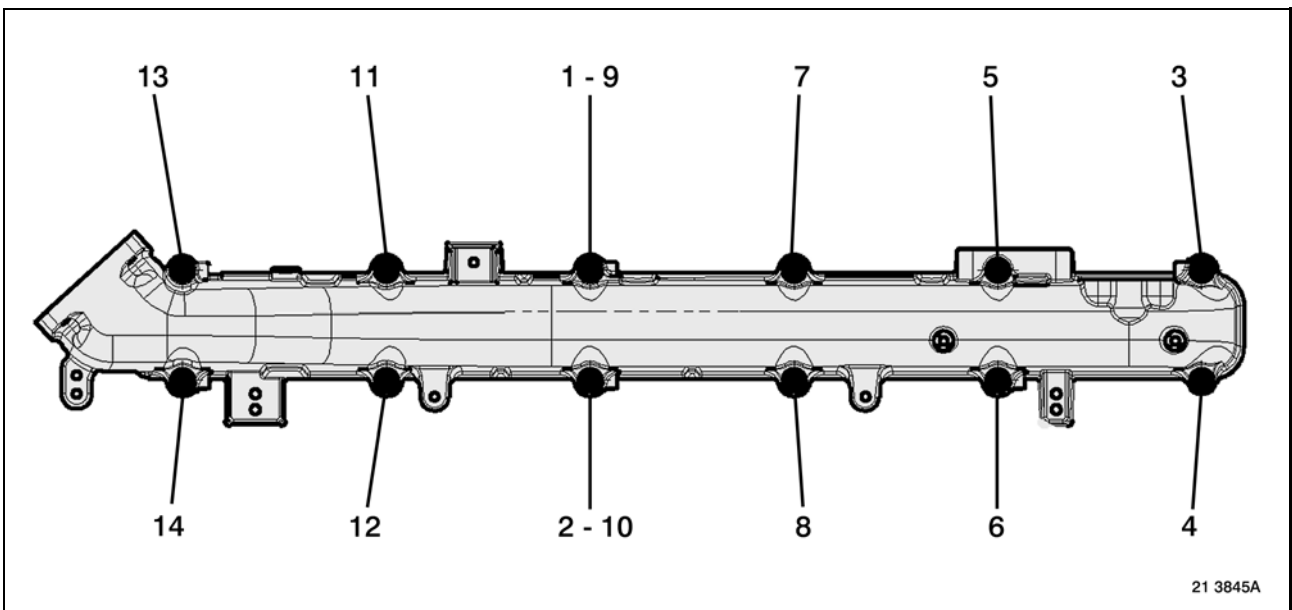

The item numbers indicate the tightening sequence.

Intake manifold securing bolts	$24^{\pm 4}$ Nm
Plug M10	$12^{\pm 2}$ Nm
Boost air pressure / temperature sensor	$10^{\pm 1.5}$ Nm

Oil sump

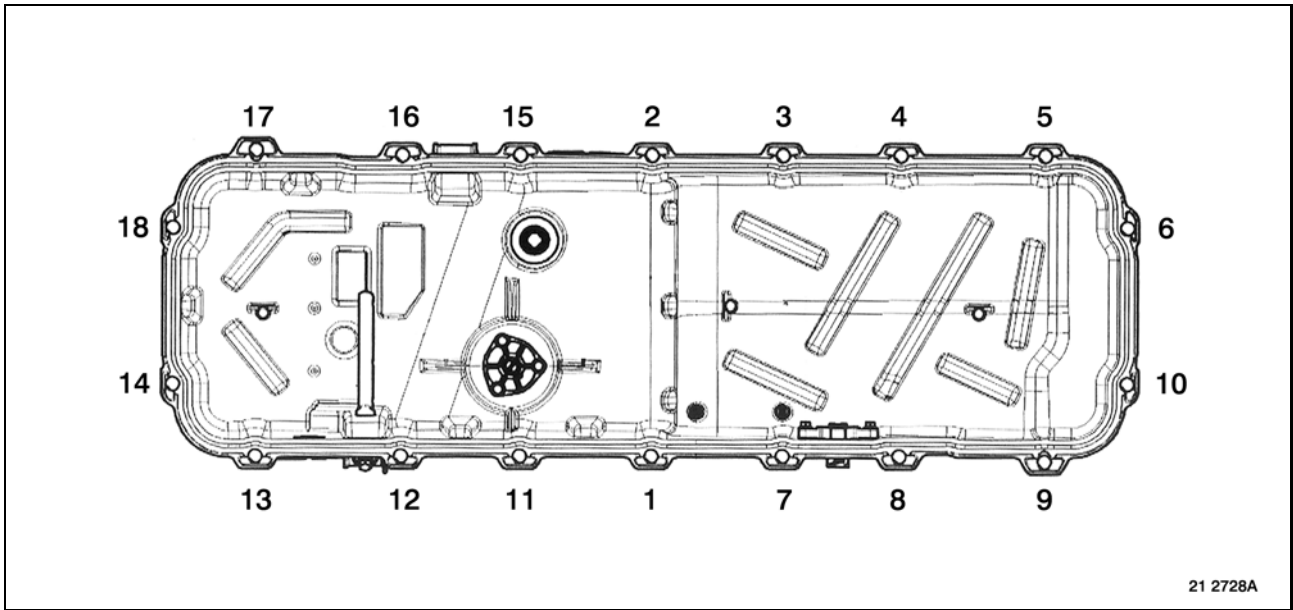

21 2728A

The item numbers indicate the tightening sequence.

Oil sump securing bolts	24^{±4} Nm
Oil sump drain plug	60^{±5} Nm
Oil dipstick securing bolt	10^{±1} Nm

Valve springs

Inlet and exhaust valves outer spring

Length uncompressed	73.8 mm
Length under a load of $590^{\pm 40}$ N	58.4 mm
Length under a load of $1150^{\pm 50}$ N	45.3 mm
Maximum solid coil length	39.5 mm

Inlet and exhaust valves inner spring

Length uncompressed	70.5 mm
Length under a load of $328^{\pm 20}$ N	54.4 mm
Length under a load of $630^{\pm 20}$ N	41.3 mm
Maximum solid coil length	36.5 mm

Rocker arms

Bearing play	0.03 → 0.08 mm
Roller play	0.04 → 0.07 mm

Maximum wear play **0.1 mm**.

Special Tools

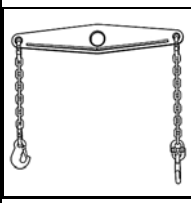
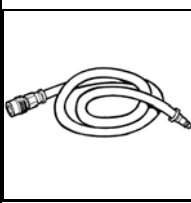
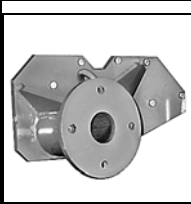
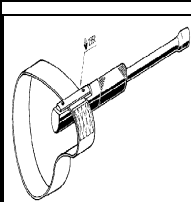
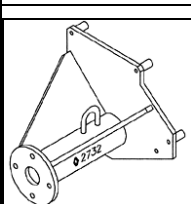
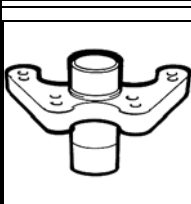
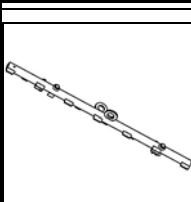
Illustration	RENAULT TRUCKS Ref.	Designation	Manufacturer reference	Manufacturer Code	Level	Qty
	7409998547	ENGINE LIFTING BEAM			1	1
	7409990115	LIFTING CHAIN			1	1
	7409996049	6-CYLINDER BLOCK DRAINAGE UNION			1	1
	5000262733	SUPPORT			2	1
	5010262595	FILTER STRAP WRENCH			1	1
	5000262732	ENGINE BRACKET FOR STAND 1000			1	1
	7409996956	ENGINE CRANKING BAR			1	1
	7409990185	LIFTING TOOL			1	1

Handling

Lifting the engine

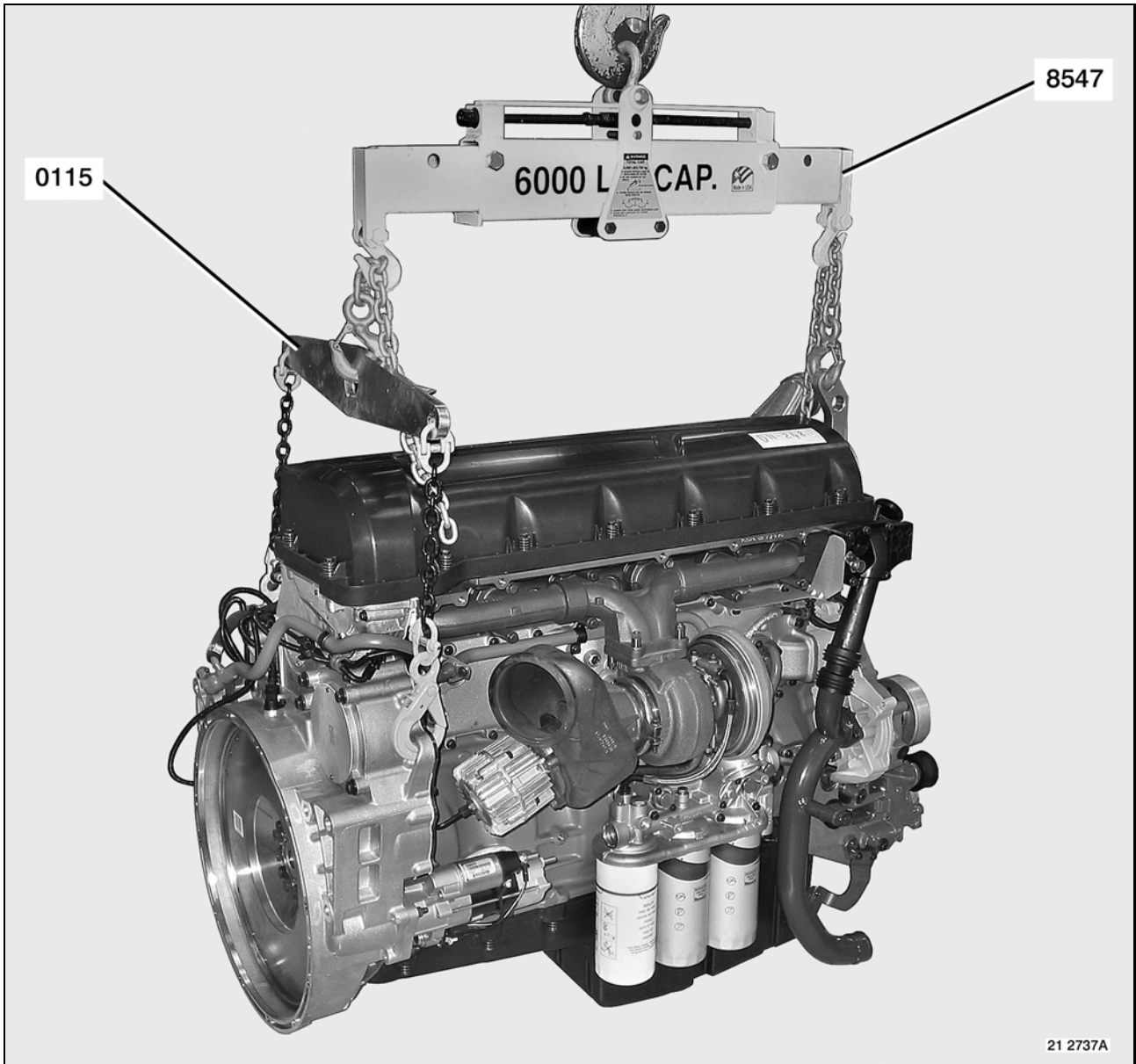

Lift the engine.
Use tool **8547 + 0115**.

Oil remover (CCCV)

Removal / Fitting

Removal of oil remover (CCCV)

Remove union (1).

Remove bolts (2).

Remove oil remover (CCCV) (3).

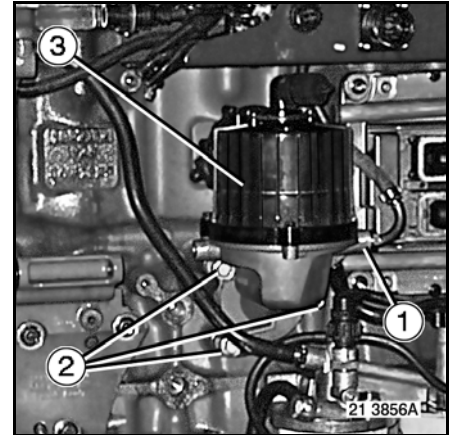

Fitting of oil remover (CCCV)

Replace gasket (1).

Lubricate the seal (1).

Use engine oil.

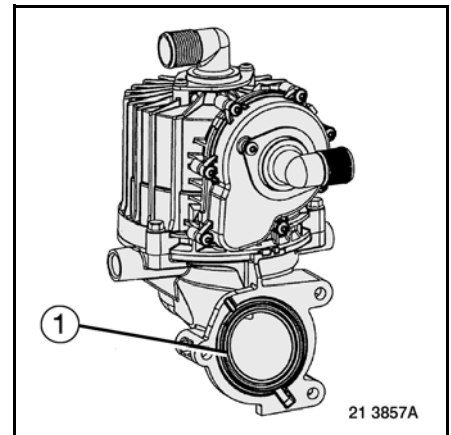

Replace gasket (1).

Lubricate the seal (1).

Use engine oil.

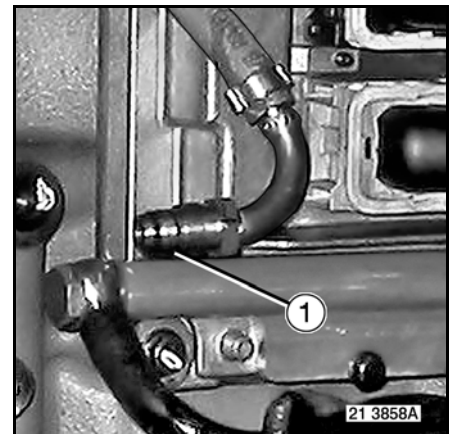

Fitting the rocker shaft

Fit yokes (1 - 2).

Line up the marks (A) made upon removal.

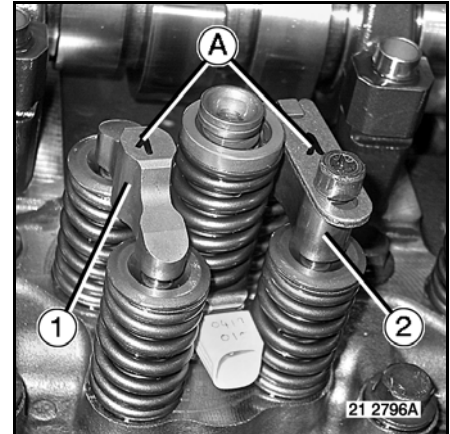

When fitting new yokes, line up the marks.

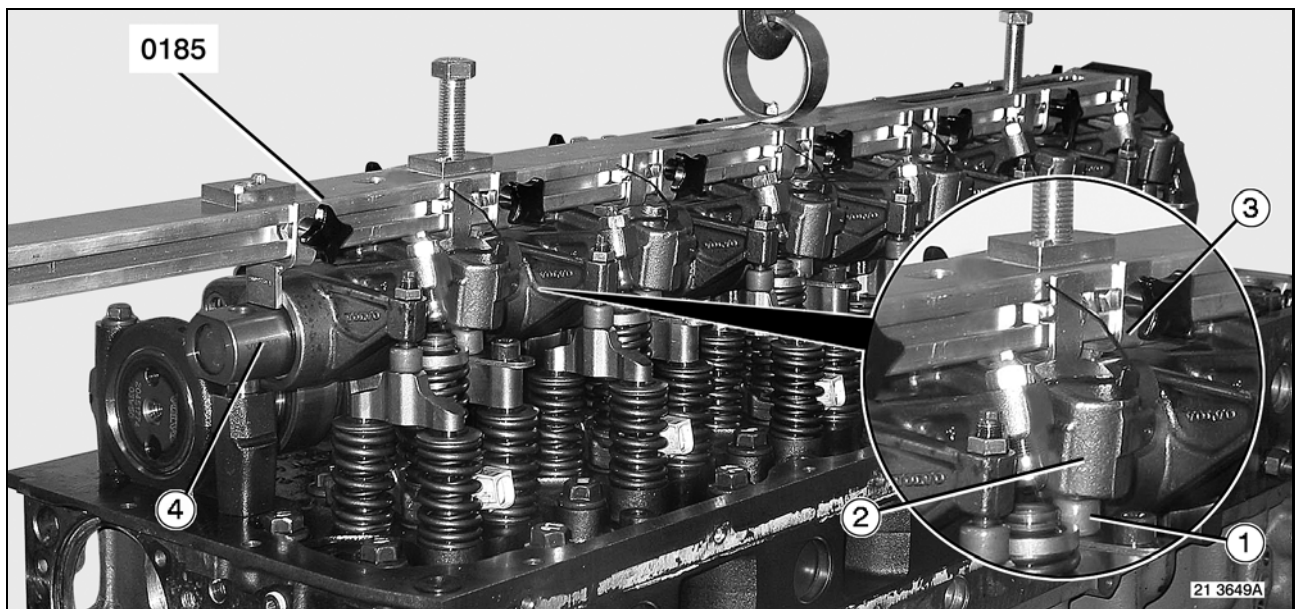
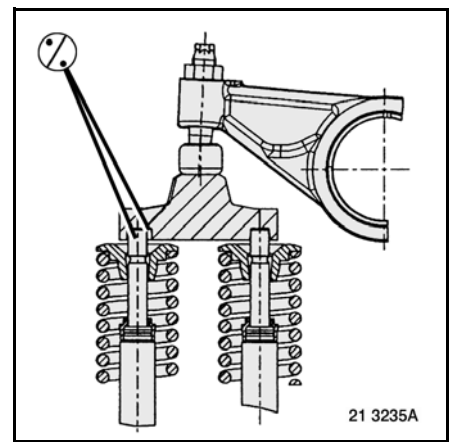

Oil all moving parts.

Remove the rocker shaft (4).

Use tool **0185**.

Cut clamps (3) to free the pistons (1) of rocker arms (2).

Inspect the rocker arms.

See page(s) F-2-4.

Removal

The item numbers indicated in the text refer to the drawing on page G-2.

Remove starter motor.

See page(s) E-8-1.

Remove compressor.

See page(s) E-6-1.

Remove the power-assisted steering pump.

See page(s) E-7-1.

Remove flywheel.

See page(s) H-8.

Remove cylinder head cover.

See page(s) F-1-2.

Remove the oil sump.

See page(s) J-5.

Remove the crankshaft rear seal.

See page(s) H-13.

Remove bolts (1).

Remove lower timing casing (2).

Remove bolts (3) M8 - (4) M12 - (5) M14.

Remove casing (6).

Remove bolts (7).

Remove pinion (8).

Use tool 0857.

Remove seal (9).

Remove pinion (10).

Save seal (11).

Loosen bolts (12 - 14 - 18) proceeding in the reverse sequence to tightening.

See page(s) B-5-17.

Remove pinions (13 - 16).

Remove vibration damper (19) and camshaft pinion (20).

Remove hub (15).

Remove washer (17).

Remove bolts (21).

Remove timing plate (22).

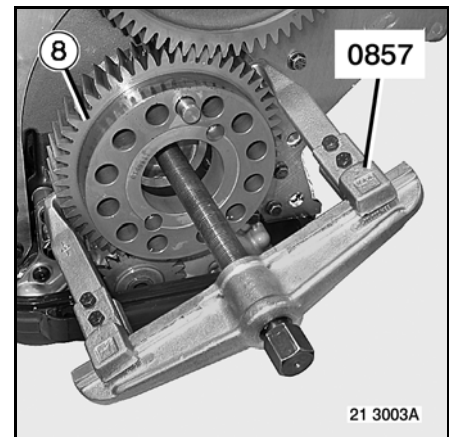

Inspection

The item numbers indicated in the text refer to the drawing on page G-2.

Check the diameter of hub (15) and of idler gear bush (16).

See page(s) B-6-9.

Check the state of the teeth of each gear and pinion.

Check the state of the pinion bearings (10 - 13).

Fitting

To fit, proceed in the reverse sequence to removal.
Retain the flywheel against motion using tool **6956**.

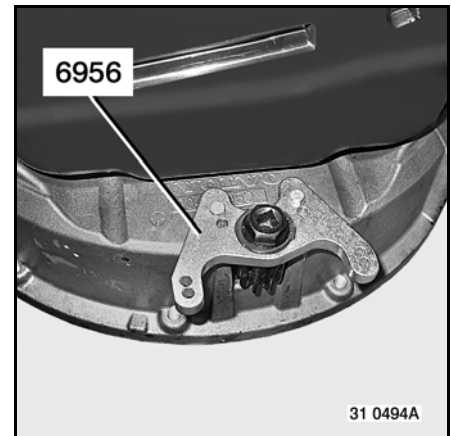

Tighten bolts **(1)** to torque following the tightening sequence.
Use tool **9776**.
See page(s) B-5-9.

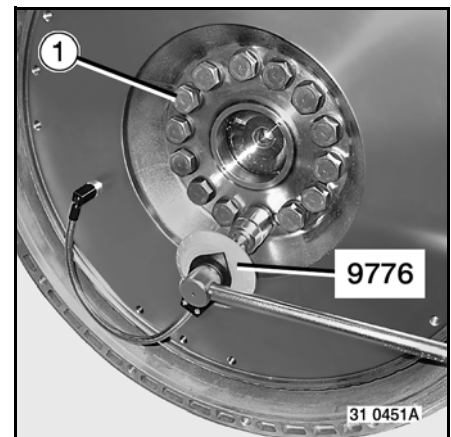

Fit engine speed sensor **(1)**.
Tighten bolt to torque.
See page(s) B-4-1.
Check the air gap.
See page(s) B-6-21.

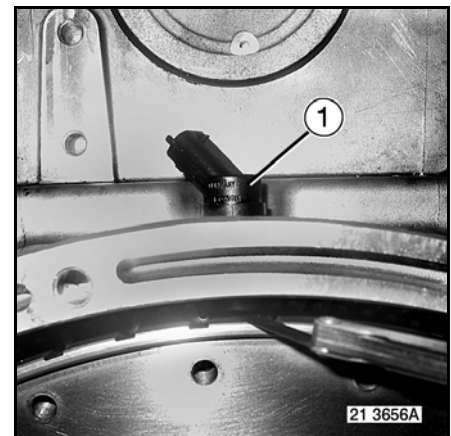

Crankshaft

Remove bolts (19).

Remove bearing caps (20).

Remove bearing half-shells (21).

Use tool **0114** + **0013**

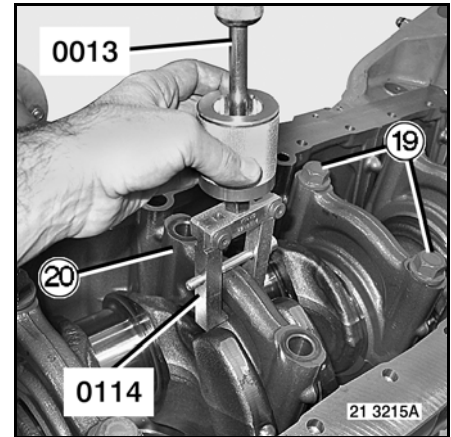

Remove half-rings (23).

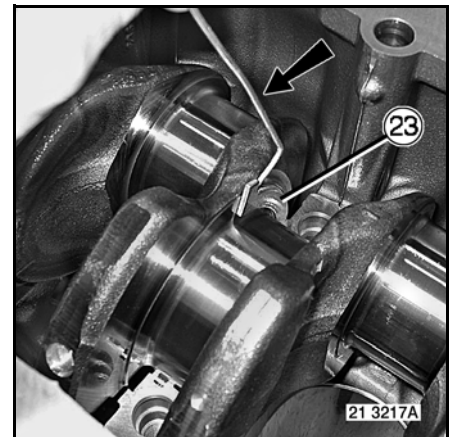

Remove crankshaft (24).

Use tool **9804**.

Use lifting tackle.

Remove bearing half-shells (22).

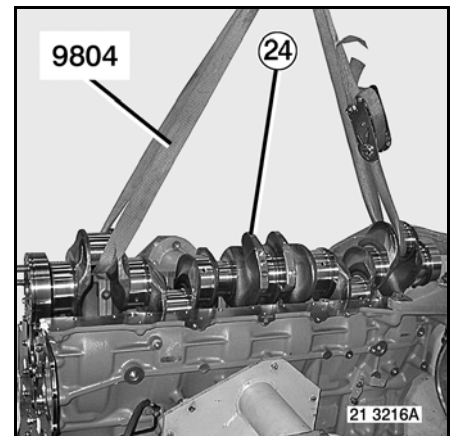

Piston

Lubricate gudgeon pin, piston and small end bush.

Assemble pistons (13) and connecting rods (14) with gudgeon pins (12).



When assembling the connecting rod / piston assembly, take care to position the marks correctly.

Install circlips (11).

Install piston rings (10 - 9 - 8).

Use tool 0825.



To avoid breakage of the piston rings during operation and during assembly / dismantling of the fire and compression rings, it is vital to not exceed the spacing distance A.

Fire ring : A = 36 mm

Compression ring : A = 34.4 mm

Oil scraper ring : A = 34.1 mm

Fit piston rings (10 - 9 - 8) so that the **TOP** markings are facing upwards.

For the oil scraper ring (10), the spring gap must be diametrically opposed to the joint gap.

The piston ring joint gaps must be staggered in relation to one another.

Fit bearing half-shells (7).

Apply oil.

Match the direction of orientation.

Apply oil to piston (engine oil).

Compress rings (8 - 9 - 10).

Use tool 0824.

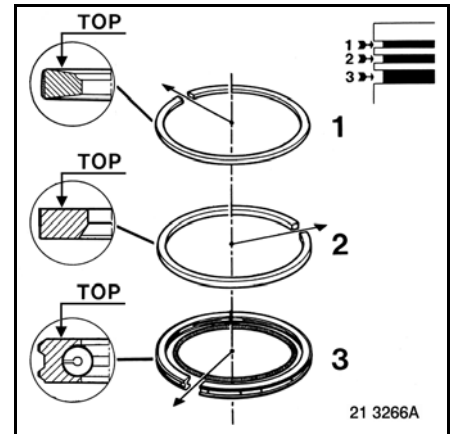

Pistons cooling pressure regulation valve

The item numbers indicated in the text refer to the drawing on page J-2.

Disassembly

Remove plug **(20)**.

Save seal **(21)**.

Remove spring **(22)**.

Remove valve **(23)**.

Inspection

Visually check the condition of the contact surface of valve **(23)**.



Check the state of the valve seat in the oil filters bracket.

Check the length of spring **(22)** under no-load and under full load.

See page(s) B-6-24.

Assembly

Proceed in the reverse sequence to removal.

Replace gasket **(21)**.

Tighten plug **(20)** to torque.

See page(s) B-5-23.