

Illustration 14

g02067853

(1) High-pressure line
(2) High-pressure line
(3) High-pressure line

(4) High-pressure line
(5) High-pressure fuel manifold (rail)
(6) High-pressure line

(7) Fuel transfer line that is high pressure

The high-pressure fuel lines are the fuel lines that are between the high-pressure fuel pump and the high-pressure fuel manifold and the fuel lines that are between the fuel manifold and cylinder head. These fuel lines are different from fuel lines on other fuel systems.

These differences are because of the following items:

- The high-pressure fuel lines are constantly charged with high pressure.
- The internal pressures of the high-pressure fuel lines are higher than other types of fuel system.
- The high-pressure fuel lines are formed to shape and then strengthened by a special process.

Do not step on the high-pressure fuel lines. Do not deflect the high-pressure fuel lines. Do not bend or strike the high-pressure fuel lines. Deformation or damage of the high-pressure fuel lines may cause a point of weakness and potential failure.

Do not check the high-pressure fuel lines with the engine or the starting motor in operation. After the engine has stopped wait 10 minutes in order to allow the fuel pressure to be purged from the high-pressure fuel lines. before any service or repair is performed.

Do not loosen the high-pressure fuel lines in order to remove air from the fuel system. This procedure is not required.

Visually inspect the high-pressure fuel lines before the engine is started. This inspection should be each day.

If you inspect the engine in operation, always use the proper inspection procedure in order to avoid a fluid penetration hazard. Refer to Operation and Maintenance Manual, "General hazard Information".

- Inspect the high-pressure fuel lines for damage, deformation, a nick, a cut, a crease, or a dent.
- Do not operate the engine with a fuel leak. If there is a leak, do not tighten the connection in order to stop the leak. The connection must only be tightened to the recommended torque. Refer to Disassembly and Assembly, "Fuel injection lines - Remove and Fuel injection lines - Install".
- If the high-pressure fuel lines are torqued correctly, and the high-pressure fuel lines are leaking the high-pressure fuel lines must be replaced.

Product Information Section

Model Views

i04231649

Model View Illustrations

The following model views show typical features of the engine and the aftertreatment system. Due to individual applications, your engine, or your aftertreatment may appear different from the illustrations.

1204E-E44TTA

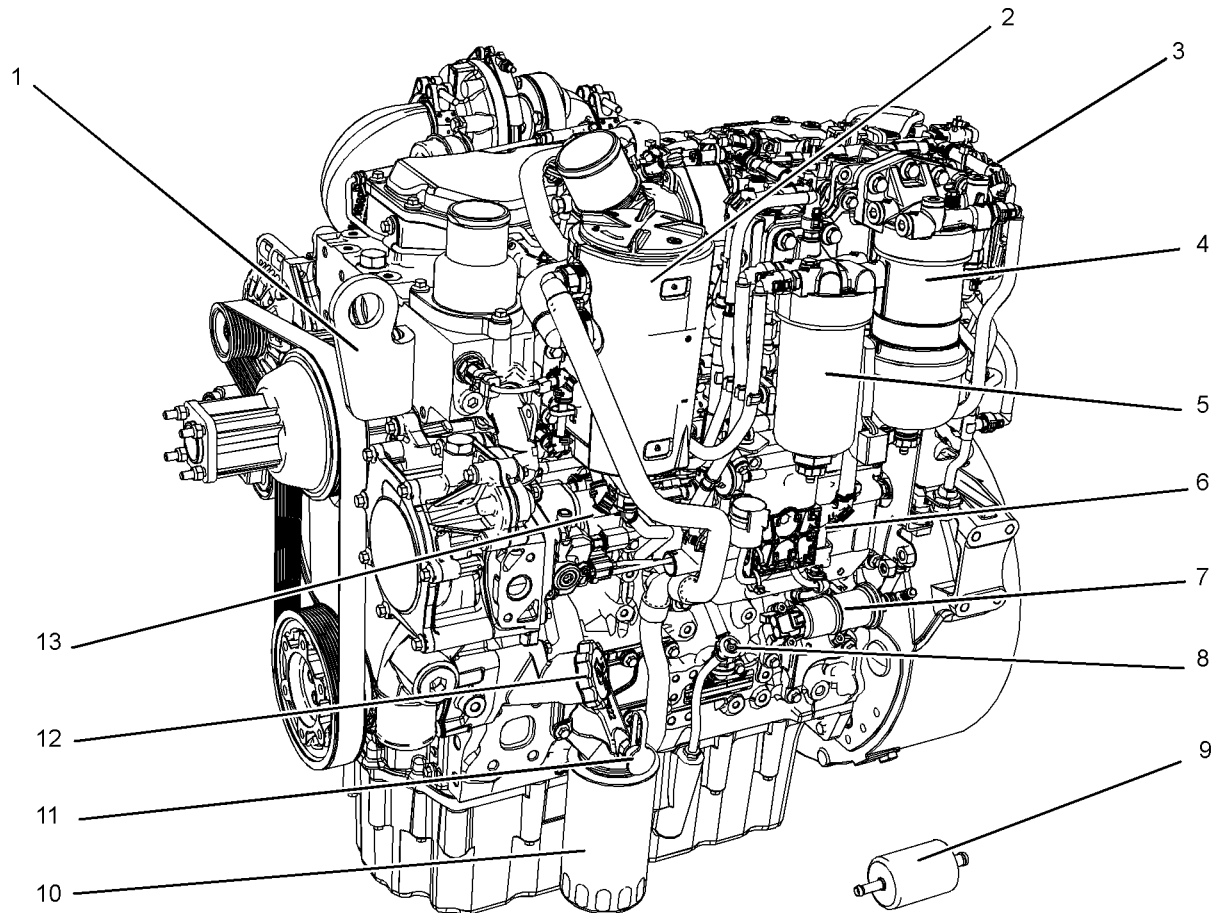

Illustration 17

g02409511

- | | | |
|--------------------------------|-------------------------------------|------------------------------|
| (1) Front lifting eye | (6) Electronic control module (ECM) | (11) Oil sampling valve |
| (2) Crankcase breather | (7) Fuel priming pump | (12) Oil filler |
| (3) NOx Reduction system (NRS) | (8) Oil gauge (dipstick) | (13) High-pressure fuel pump |
| (4) Primary fuel filter | (9) Fuel strainer | |
| (5) Secondary fuel filter | (10) Oil filter | |

Engine Diagnostics

i04215570

Self-Diagnostics

i02651093

Perkins electronic engines have the capability to perform a self-diagnostics test. When the system detects an active problem, a diagnostic lamp is activated. Diagnostic codes will be stored in permanent memory in the Electronic Control Module (ECM). The diagnostic codes can be retrieved by using the electronic service tool. Refer to Troubleshooting , “Electronic Service Tools” for further information.

Some installations have electronic displays that provide direct readouts of the engine diagnostic codes. Refer to the manual that is provided by the OEM for more information on retrieving engine diagnostic codes. Alternatively refer to Troubleshooting , “Indicator Lamps” for further information.

Active codes represent problems that currently exist. These problems should be investigated first.

Logged codes represent the following items:

- Intermittent problems
- Recorded events
- Performance history

The problems may have been repaired since the logging of the code. These codes do not indicate that a repair is needed. The codes are guides or signals when a situation exists. Codes may be helpful to troubleshoot problems.

When the problems have been corrected, the corresponding logged fault codes should be cleared.

i02651107

Diagnostic Lamp

A diagnostic lamp is used to indicate the existence of an active fault. Refer to Troubleshooting , “Indicator Lamps” for more information. A fault diagnostic code will remain active until the problem is repaired. The diagnostic code may be retrieved by using the electronic service tool. Refer to Troubleshooting , “Electronic Service Tools” for more information.

Diagnostic Flash Code Retrieval

Use the “DIAGNOSTIC” lamp or an electronic service tool to determine the diagnostic flash code.

Use the following procedure to retrieve the flash codes if the engine is equipped with a “DIAGNOSTIC” lamp:

1. Move the keyswitch from the on/off two times within 3 seconds.

A flashing YELLOW lamp indicates a 3-digit code for the engine. The sequence of flashes represents the system diagnostic message. Count the first sequence of flashes in order to determine the first digit of the flash code. After a two second pause, the second sequence of flashes will identify the second digit of the flash code. After the second pause, the third sequence of flashes will identify the flash code.

Table 3

Flash Code Table	
Description	Flash Code
Injector fault	111
Injector number 2 current out of range	112
Injector number 3 current out of range	113
Injector number 4 current out of range	114
Injector number 5 current out of range (6 cylinder only)	115
Injector number 6 current out of range (6 cylinder only)	116
Intake manifold air temperature sensor out of range	133
Engine speed sensor out of range	141
Engine timing offset fault	143
Engine operation mode selector switch erratic, intermittent, or incorrect	144
High air filter restriction - Warning	151
Atmospheric pressure sensor out of range	152
Throttle position sensor out of range	154
Secondary throttle position sensor out of range	155
Oil pressure sensor out of range	157

(continued)

- Independent laboratory

Additives

Additives help to protect the metal surfaces of the cooling system. A lack of coolant additives or insufficient amounts of additives enable the following conditions to occur:

- Corrosion
- Formation of mineral deposits
- Rust
- Scale
- Foaming of the coolant

Many additives are depleted during engine operation. These additives must be replaced periodically.

Additives must be added at the correct concentration. Over concentration of additives can cause the inhibitors to drop out-of-solution. The deposits can enable the following problems to occur:

- Formation of gel compounds
- Reduction of heat transfer
- Leakage of the water pump seal
- Plugging of radiators, coolers, and small passages

Glycol

Glycol in the coolant helps to provide protection against the following conditions:

- Boiling
- Freezing
- Cavitation of the water pump

For optimum performance, Perkins recommends a 1:1 mixture of a water/glycol solution.

Note: Use a mixture that will provide protection against the lowest ambient temperature.

Note: 100 percent pure glycol will freeze at a temperature of $-13\text{ }^{\circ}\text{C}$ ($8.6\text{ }^{\circ}\text{F}$).

Most conventional antifreezes use ethylene glycol. Propylene glycol may also be used. In a 1:1 mixture with water, ethylene and propylene glycol provide similar protection against freezing and boiling. Refer to Table 9 and refer to table 10.

Table 9

Ethylene Glycol	
Concentration	Freeze Protection
50 Percent	$-36\text{ }^{\circ}\text{C}$ ($-33\text{ }^{\circ}\text{F}$)
60 Percent	$-51\text{ }^{\circ}\text{C}$ ($-60\text{ }^{\circ}\text{F}$)

NOTICE

Do not use propylene glycol in concentrations that exceed 50 percent glycol because of the reduced heat transfer capability of propylene glycol. Use ethylene glycol in conditions that require additional protection against boiling or freezing.

Table 10

Propylene Glycol	
Concentration	Freeze Protection
50 Percent	$-29\text{ }^{\circ}\text{C}$ ($-20\text{ }^{\circ}\text{F}$)

To check the concentration of glycol in the coolant, measure the specific gravity of the coolant.

Coolant Recommendations

- ELC _____ Extended Life Coolant
- SCA _____ Supplement Coolant Additive
- ASTM _____ American Society for Testing and Materials

The following two coolants are used in Perkins diesel engines:

Preferred – Perkins ELC

Acceptable – A commercial heavy-duty antifreeze that meets “ASTM D6210 ” specifications

NOTICE

The 1200 series industrial engines must be operated with a 1:1 mixture of water and glycol. This concentration allows the NOx reduction system to operate correctly at high ambient temperatures.

NOTICE

Do not use a commercial coolant/antifreeze that only meets the ASTM D3306 specification. This type of coolant/antifreeze is made for light automotive applications.

Perkins recommends a 1:1 mixture of water and glycol. This mixture of water and glycol will provide optimum heavy-duty performance as an antifreeze. This ratio may be increased to 1:2 water to glycol if extra freezing protection is required.

3. Pour the correct coolant mixture into the tank. Refer to the Operation and Maintenance Manual, "Refill Capacities and Recommendations" for information on the correct mixture and type of coolant. Refer to the Operation and Maintenance Manual, "Refill Capacities and Recommendations" for the cooling system capacity. Do not fill the coolant recovery tank above "COLD FULL" mark.

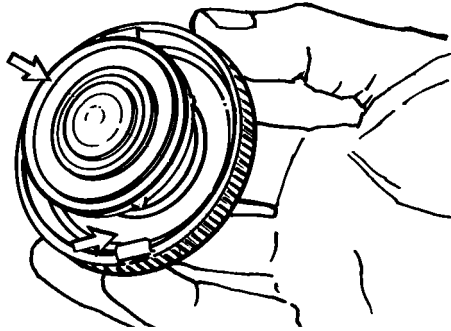

Illustration 52

g00103639

4. Clean filler cap and the receptacle. Reinstall the filler cap and inspect the cooling system for leaks.

Note: The coolant will expand as the coolant heats up during normal engine operation. The additional volume will be forced into the coolant recovery tank during engine operation. When the engine is stopped and cool, the coolant will return to the engine.

Engines Without a Coolant Recovery Tank

Check the coolant level when the engine is stopped and cool.

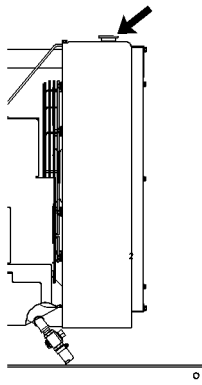

Illustration 53

g00285520

Cooling system filler cap

⚠ WARNING

Pressurized System: Hot coolant can cause serious burns. To open the cooling system filler cap, stop the engine and wait until the cooling system components are cool. Loosen the cooling system pressure cap slowly in order to relieve the pressure.

1. Remove the cooling system filler cap slowly in order to relieve pressure.
2. Maintain the coolant level at the maximum mark that is correct for your application. If the engine is equipped with a sight glass, maintain the coolant level to the correct level in the sight glass.
3. Clean the cooling system filler cap and inspect the gasket. If the gasket is damaged, discard the old filler cap and install a new filler cap. If the gasket is not damaged, use a suitable pressurizing pump in order to pressure test the filler cap. The correct pressure is stamped on the face of the filler cap. If the filler cap does not retain the correct pressure, install a new filler cap.
4. Inspect the cooling system for leaks.

i03644948

Cooling System Supplemental Coolant Additive (SCA) - Test/Add

⚠ WARNING

Cooling system coolant additive contains alkali. To help prevent personal injury, avoid contact with the skin and the eyes. Do not drink cooling system coolant additive.

Test for SCA Concentration

Heavy-Duty Coolant/Antifreeze and SCA

NOTICE

Do not exceed the recommended six percent supplemental coolant additive concentration.

Use a Coolant Conditioner Test Kit in order to check the concentration of the SCA.

Reference Information Section

Reference Materials

i04224089

Engine Protection Plans (Extended Service Contract)

Extended Service Contracts-purchased in minutes,
protected for years.

Extended Service Contracts (ESC) protect you from
the stress that unexpected repair work brings to your
life by covering the cost of getting your engine up
and running again. Unlike other extended warranties,
Perkins Platinum ESC protects you against all
component part failures.

Purchase peace of mind from only £0.03 / \$0.05 /
euro 0.04 a day and let an ESC make your dreams
a reality.

Why buy an Extended Service Contract?

1. No surprises - total protection from unexpected
repair cost (parts, labor, and travel).
2. Enjoy longer lasting product support from Perkins
global network.
3. Genuine Perkins parts ensure continued engine
performance.
4. Highly trained technicians carry out all repairs.
5. Transferable coverage should you sell your
machine.

Flexible coverage provides the right level of protection
for your Perkins Engine. Coverage can be extended
to 2 years/ 1,000 hours right up to 10 year/ 40,000

You can buy an ESC at any time during standard
warranty - even the last day!

Each Perkins Distributor has highly trained and
experienced Perkins Product Support Service
Technicians. The Support Service are equipped, and
available around the clock to get your engine running
again with the minimum of downtime. Buying an ESC
means that you get all this for free.

To purchase an Extended Service Contract, is quick
and simple! Contact your local Perkins Distributor
now and the distributor can provide you with a quote
in minutes. You can locate your nearest Perkins
Distributor by visiting:

www.perkins.com

NOTICE

Dependant upon engine type and application.

2.4 Engine & Aftertreatment Component Layout Diagrams

2.4.1 1204E Principle Engine Electronic Components

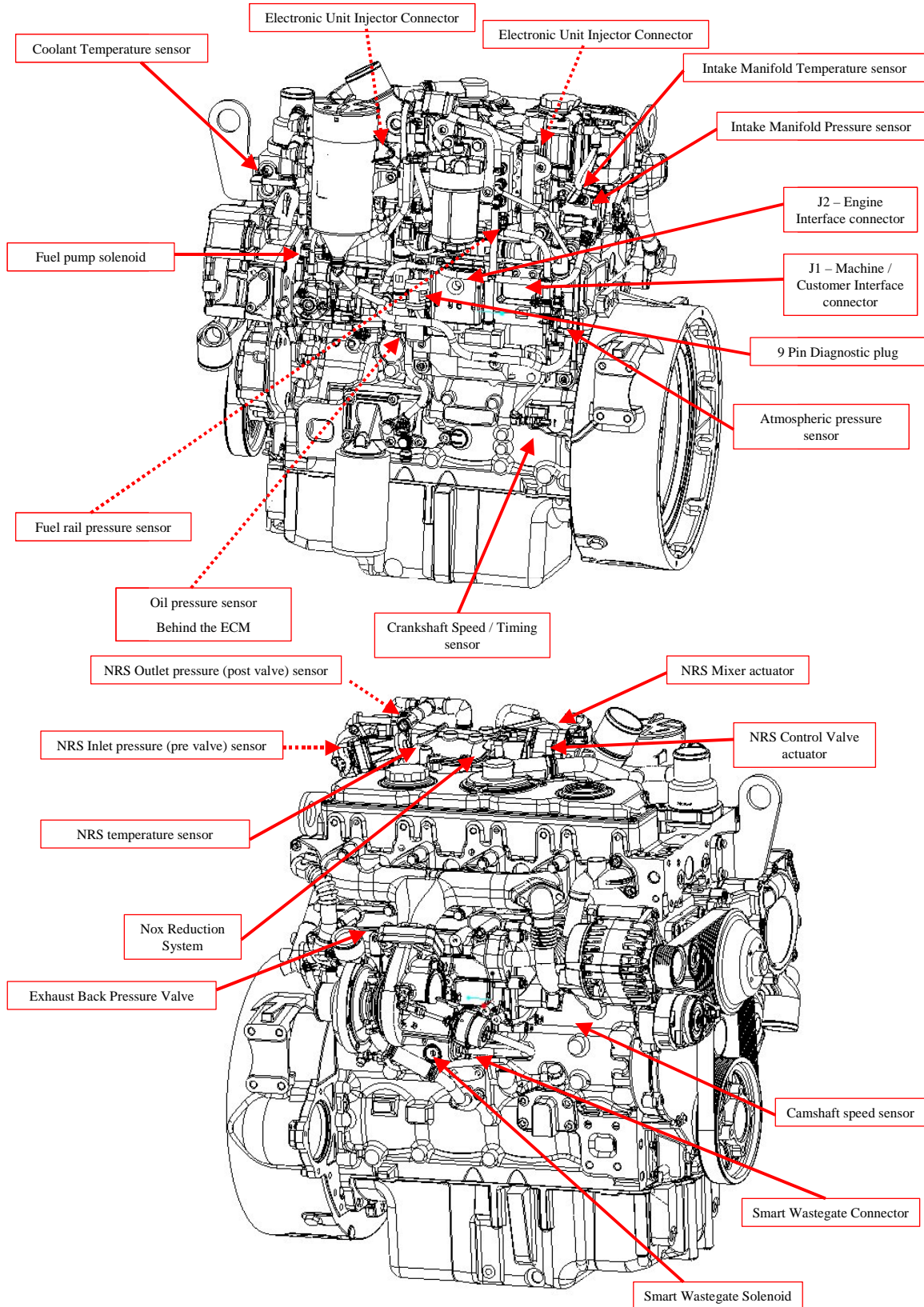

4.4 Engine ECM Power Supply Circuit Resistance Test

Component	Perkins part number	Supplier Part number	Quantity
J1 Receptacle		776184-1	1
Pins	T400047	0460-202-16141	10
2.2 Ohm Resistor 200W	N/A	N/A	1
Relay (low contact resistance)	N/A	N/A	1
Pushbutton	N/A	N/A	1
Voltmeter	N/A	N/A	2

Table 4.4 ECM Power Supply Circuit Test Components

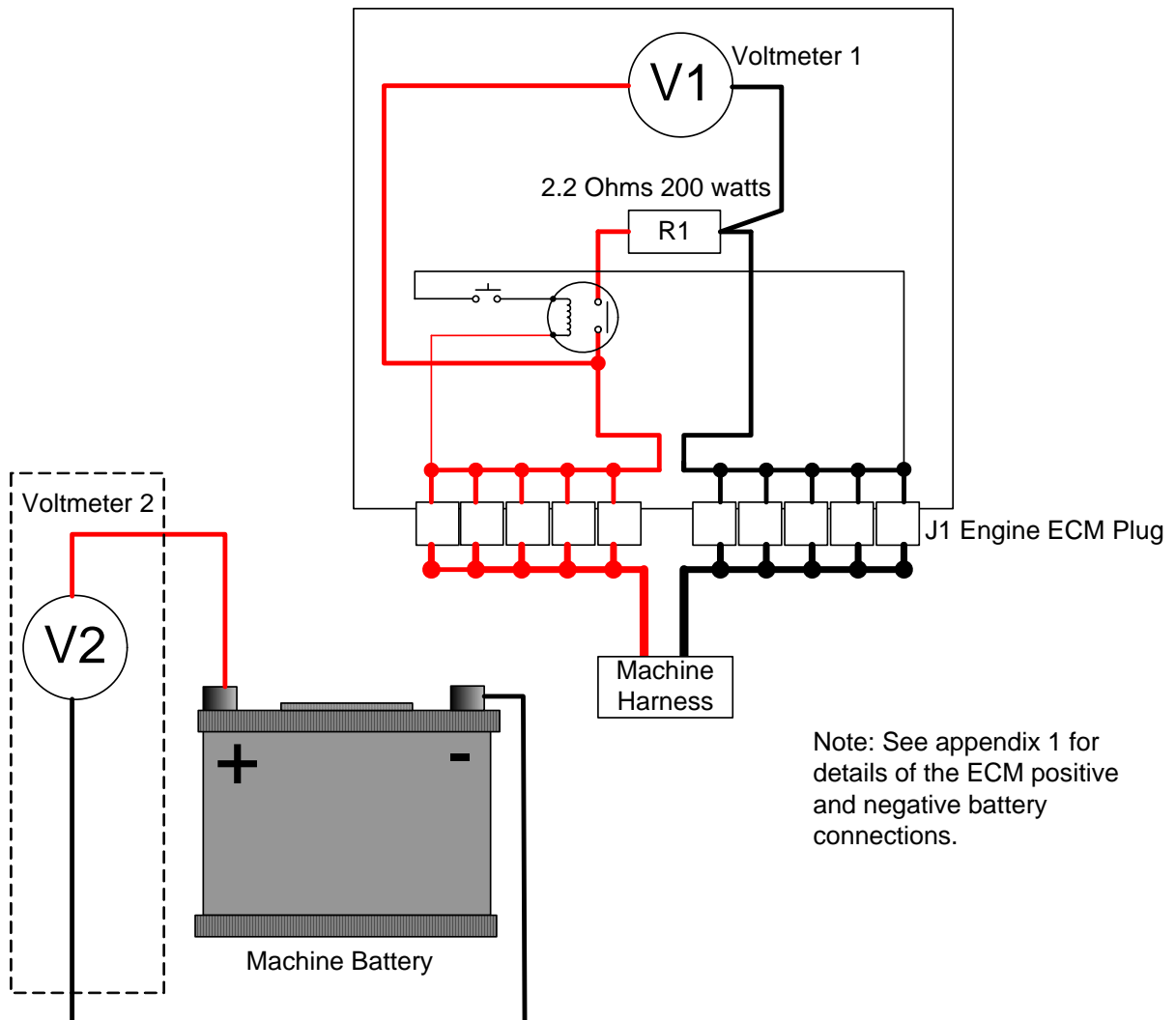

Figure 4.6 ECM Power Supply Circuit Resistance Testing

Note: The total ECM supply circuit resistance forms part of the Application Appraisal. Circuits which do not meet the 50mOhm

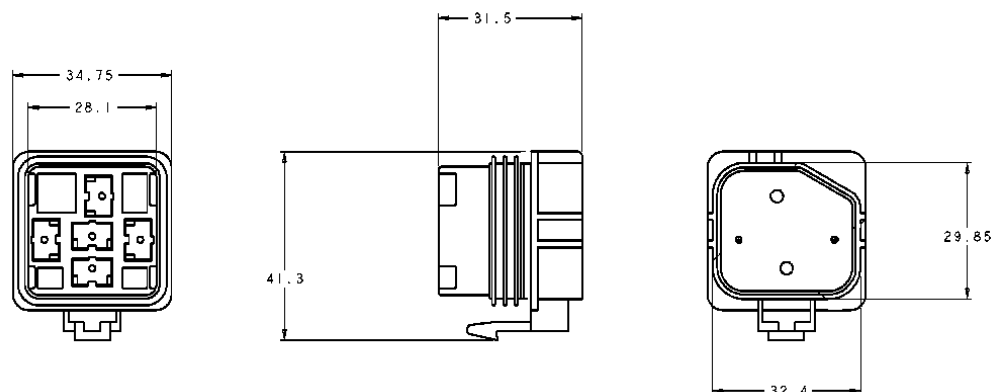

Figure 6.20 ARD Fuel Pump Control Relay Connector

Description	Perkins Part Number	Supplier Part Number (Delphi Packard)
12V Relay	T406990	-
24V Relay	T406333	-
Plug Connector	TBD	12065686
12AWG Terminal	TBD	12033997
14 – 16AWG Terminal	TBD	12066614
Crimp Tool	TBD	TBD

Table 6.13 ARD Fuel Lift Pump Relay and Connection Part Numbers

When installing the ARD fuel pump and relay the following relay contacts must be used along with the corresponding Terminal as shown below;

- T30 – Main Battery Supply Feed
- T87 – Main Battery Feed to ARD Pump via N/O Contact
- T85 – Relay Coil Control
- T86 – Relay Coil Control

The wiring schematics for each of the two fuel pump voltage options are shown in figure 6.20.

9.5 Torque Speed Control TSC1 (Speed Control Over CAN)

A special J1939 message called Torque/Speed Control #1 (TSC1) allows other electronic devices to control or to limit the engine speed. This message is explained in detail in section 19 of this application and installation guide.

9.6 Arbitration of speed demand

In applications where there is more than one source of engine speed demand, it is necessary to arbitrate between the different demands. The speed arbitration does not apply to the PTO speed demand feature. There are 4 methods of arbitration:

- Max Wins. The highest speed demand is the one that controls the engine. This is the default configuration
- Manual Selection switch. A switch input can be used to define which speed input has control. This is particularly useful in applications where there are 2 driver seat positions.
- TSC1 override. As described above, the TSC1 message over J1939 will override speed demand from any other source.
- Intermediate engine speed switch. Used as part of the MPTS function but will override all speed demands when operated including TSC1.
- Lowest wins. In this case the low engine speed demanded will be the overall speed selected.

9.6.1 Manual Throttle Selection Switch

A switch input is available on pin 40 of the ECM J1 connector, which can be configured to manually select the active speed demand channel. If the switch is configured for use (this must be done using the EST service tool), then if the switch input is open, speed demand 1 is selected. If the switch is closed, speed demand 2 is selected.

9.7 Acceleration and Deceleration Ramp Rates

It is possible to limit the overall acceleration rate of the engine speed. The acceleration limit applies to overall engine speed, irrespective of applied strategy. The rate may be configured using EST. The rate is defined in units of rpm per second. 0 rpm/s represents no limit to engine acceleration (i.e. turns off the feature.) The default ramp rate will be 0 rpm/s.

When ramp rates are being used within the PTO function it should be noted that if overall acceleration and deceleration ramp rates are also being used the engine software will apply the lower of the two values.

Start Aid Control

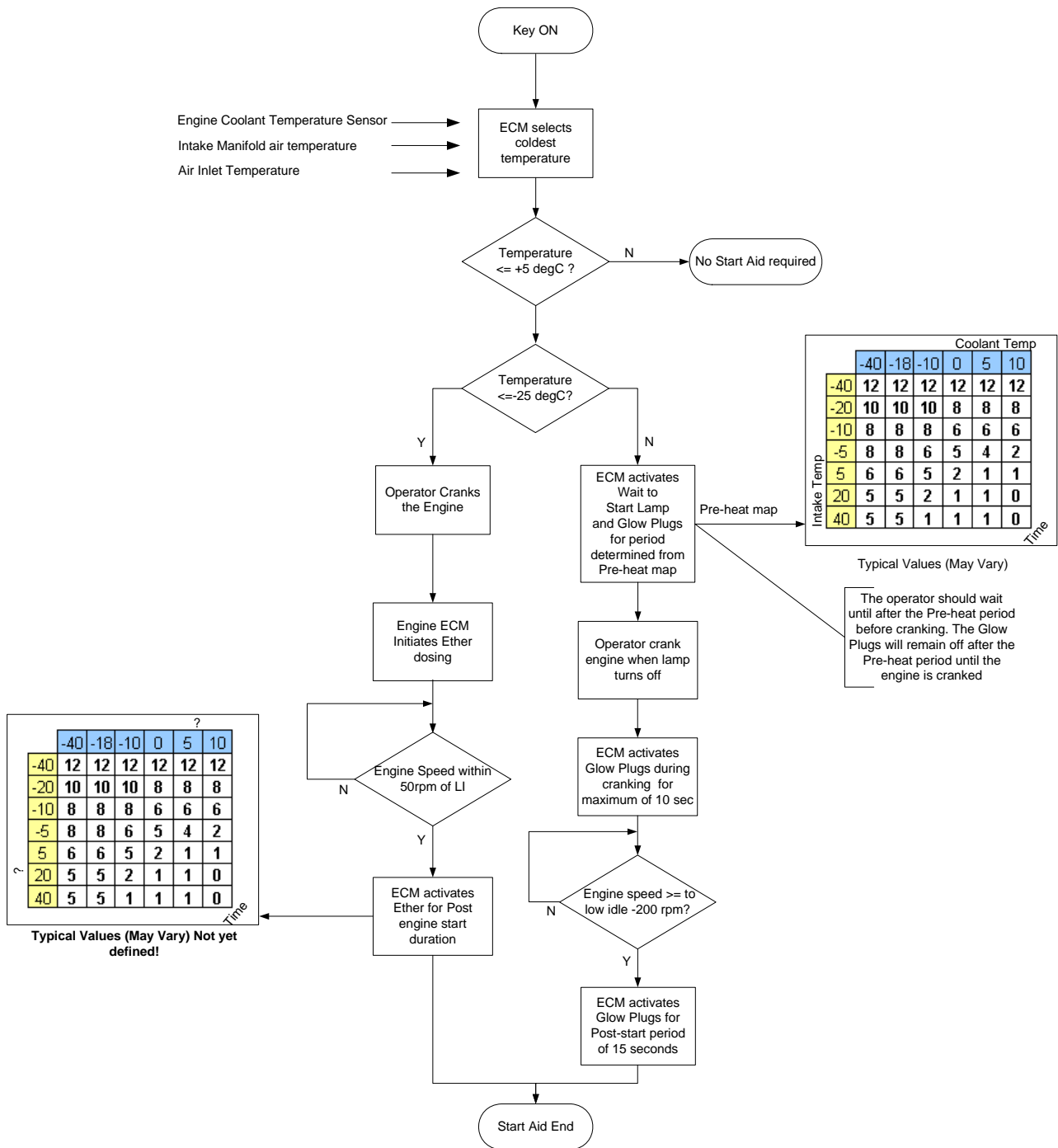

Figure 10.1 ECM Start Aid Control

11.3.2.2 1206E-E70TTA Engine / Aftertreatment Lamp Logic



































Warning Lamp (Also known as Alert Lamp)	Shutdown Lamp/buzzer (Also known as Action Lamp)	Regeneration Active (Also known as HEST Lamp)	Diesel Particulate Filter	DPF Disabled	State Description
 On	 On	 On	 On	 On	Lamp Check
 Off	 Off	 Off	 Off	 Off	No Faults Present.
 Off	 Off	 On	 Off	 Off	High Exhaust Temperature On During Active Regeneration if machine stationary Or during cool down immediately following an active regeneration until DPF out temperature falls below 450°C, or machine goes back to work.
 Off	 Off	 Off	 On	 Off	DPF Above 80% Soot loading, warns the operator that regeneration is required
 Off	 Off	 Off	 Off	 On	Regeneration disabled by operator or machine
 Flash	 Off	 Off	 On	 Off	DPF Above 100% Soot Loading, engine power derates dependent on soot load, regeneration required
 Flash	 On	 Off	 On	 Off	DPF Above 116% Soot Loading, engine shutdown

Table 11.8 1206E-E70TTA Engine Lamp Logic

Table 13.6 Low Coolant Level Monitoring Mode Operation Configuration

13.2.3 Coolant Level Switch Installation

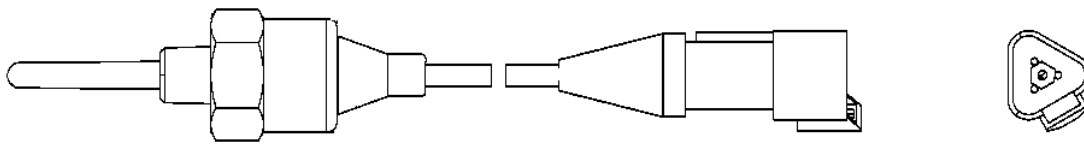

Figure 13.3 Coolant Level Switch T400042

To ensure the correct operation of the engine monitoring system for the coolant level switch the Perkins approved part shown in table 13.6 must be used. Table 13.6 also provides the part numbers required to connect to the coolant level switch.

REQUIRED PARTS			
Perkins Part Number	Supplier Part Number	Description	Qty
T400042	N/A	Coolant Level Switch	1
28170056	N/A	Connector Plug Kit	1
N/A	DT06-3S-EP06	Plug	1
N/A	W3S-P012	Wedge Lock	1
2900A016	0462-201-1631	Connector Socket (Gold)	3

Table 13.6 Coolant level switch Installation Parts List

The coolant level switch is a three wire switch which requires connection to the ECM J1 analogue 5V sensor supply and ground pins as shown in figure 13.4

COOLANT LEVEL SWITCH

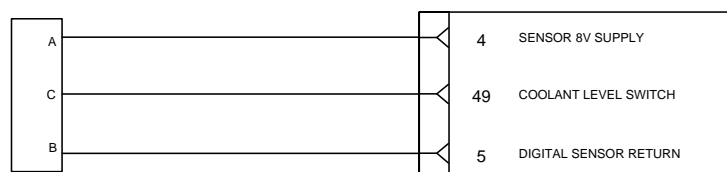

Figure 13.4 Coolant Level Switch Installation Wiring

13.3 Water In Fuel Trap Switch

13.3.1 Water In Fuel Trap Switch Operation

The water in fuel switch indicates that the fuel filter bowl is full. During normal engine operation the switch is immersed in diesel fuel. As water collects and reaches the maximum level the water enables a conductive path between electrodes (normally open switch). The WIF switch is supplied assembled to all engines and is a mandatory installation item. The electrical connection of

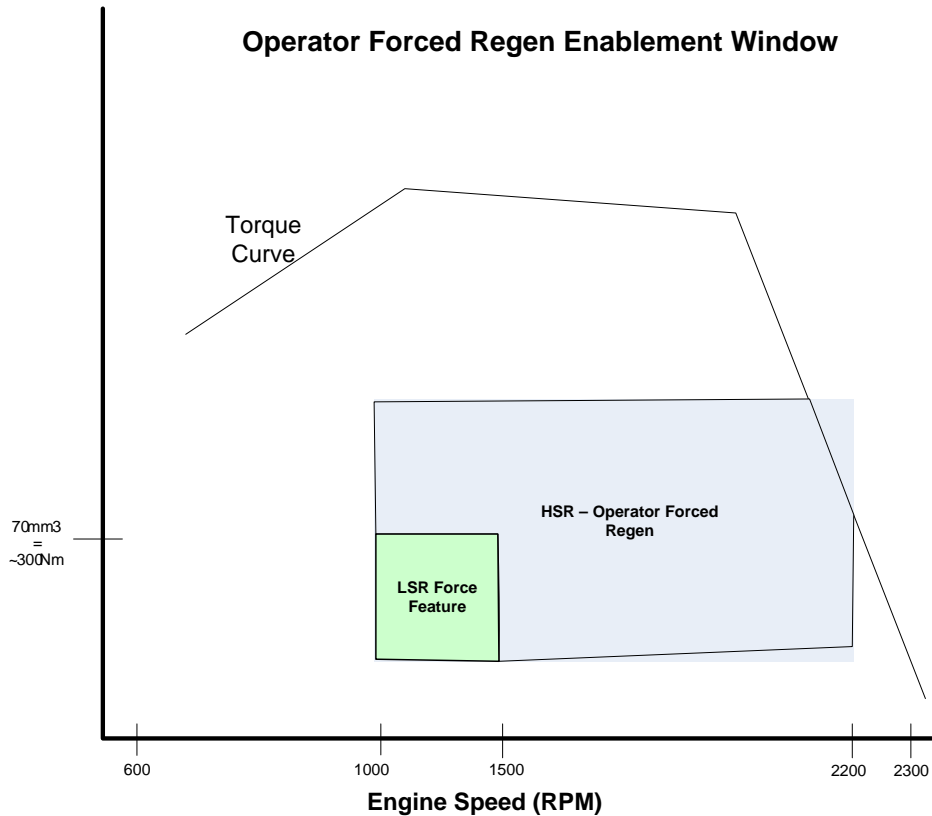

Figure 14.9 Operator Forced Regeneration Activation

14.4.7.2 Regeneration Force/Inhibit Interface Switch Configuration

All 1206E-E70TTA engines have this feature default “Installed” through Perkins EST. If the J1939 command messages are to be used instead of a hard wired switch, then this parameter must be changed to “Not Installed” Applications using the J1939 control option should refer to J1939 Applications Integration Section 19 of this document for more information on the PGN and SPN used to control this function.

14.4.7.3 Regeneration Force/Inhibit Interface Switch Installation

Perkins can provide a switch designed to provide both the force and inhibit functions to the machine operator. This component is available via the Perkins parts system and can be ordered using the part numbers shown in the table below.

Component	Perkins P/N
ARD Switch	TBD
Terminals	TBD
Wire Grommet	TBD
Plug Connector	TBD
Crimp Tooling	TBD

Table 14.3 Regeneration Interface Switch Assembly Part Numbers

	Brake System				1010				
	Not defined (1011 – 1101)								
	Other				1110				
	Not available				1111				
	Not Defined		5..8						
X	Drivers Demand Engine - Percent Torque (SPN 512)	2	1	8		%	1%/bit	0	125
X	Actual Engine - Percent Torque (SPN 513)	3	1	8		%	1%/bit	0	125
X	Engine Speed (SPN 190)	4	1	16		rpm	0.125rpm/bit	0	8,031.875
	Source Address of Controlling Device for Engine Control (SPN 1483)	6	1	8		None	1	0	253
	Engine Starter Mode (SPN 1675)	7	1	4					
X	Engine demand – percent torque (SPN 2432)	8	1	8		%	1%/bit	0	125

Note A: The J1939 standard describes the frequency of transmission of this PGN as engine speed dependant. The ECM actually transmits the message every 20ms, however, irrespective of engine speed.

Note B: During the engine cranking cycle while the ECM is detecting engine position and speed, engine speed is transmitted as FE00 or “Unavailable”. When this value is converted to engine speed it gives the value of 8128rpm.

19.3.4 Turbocharger Wastegate (TCW) (65174)

TCW contains the SPN, turbocharger 1 wastegate drive. This transmitted value directly equates to the PWM duty cycle of the smart wastegate solenoid. A value of 0% represents fully closed and a value of 100% represents fully open. Due to the fact that the wastegate is also intake manifold pressure dependent, this value does not necessarily align to the actual position of the smart wastegate.

Identifier	Rate (msec)	PGN	Default Priority	R1	DP	Source	Destination
18FE9600	100	FE96	6	0	0	00	-

S	R	Parameter name	B	B	L	S	U	Resolution (unit/bit)	Range		N
									y	i	
X		Turbocharger 1 Wastegate Drive (spn 1188)	1	1	8		%	0.4%/bit	0	100	
		Turbocharger 2 Wastegate Drive	2	1	8						
		Turbocharger 3 Wastegate Drive	3	1	8						
		Turbocharger 4 Wastegate Drive	4	1	8						
		Turbocharger Wastegate Act Control Pressure	5	1	8						