

Technical Service Information

NISSAN RE4R01A

INDEX

SYMPTOM CHART.....	3
OIL CHANNELS	5
CONTROL SYSTEM	6
SELF DIAGNOSIS	8
APPLICATION CHART	14
HYDRAULIC LAYOUT	15
WIRING DIAGRAMS.....	16
TEAR DOWN - ASSEMBLY.....	19
CONTROL VALVE ASSEMBLY.....	36
CLUTCH PACK.....	50
SPECIFICATIONS.....	92
SPACER PLATE DIAGRAMS	95
LINE PRESSURE	96
TORQUE SPECIFICATIONS - BAND ADJUSTMENT	97
REPEAT PLANETARY FAILURE	98
SOLENOID DESCRIPTION	104
ELECTRICAL PARTS LOCATION 300ZX	105
ELECTRICAL PARTS LOCATION 240SX	106
ELECTRICAL PARTS LOCATION PATHFINDER.....	107

Technical Service Information

Symptom Chart (Cont'd)

		ON vehicle														OFF vehicle														
		Fluid level	Control linkage	Inhibitor switch	Throttle sensor (Adjustment)	Revolution sensor and speed sensor	Engine revolution signal	Engine idling rpm	Line pressure	Control valve assembly	Shift solenoid A	Shift solenoid B	Line pressure solenoid	Lock-up solenoid	Overrun clutch solenoid	Fluid temperature sensor	Accumulator N.D.	Accumulator 1-2	Accumulator 2-3	Accumulator 3-4 (N.R)	Ignition switch and starter	Torque converter	Oil pump	Reverse clutch	High clutch	Forward clutch	Forward one-way clutch	Overrun clutch	Low one-way clutch	Low & reverse brake
-	Too sharp a shock in change from "D ₃ " to "D ₄ ".	.	.	.	1	.	.	.	2	4	3	6	.	5	.
-	Almost no shock or clutches slipping in change from "D ₁ " to "D ₃ ".	1	.	.	2	.	.	.	3	5	4	6	.
-	Almost no shock or slipping in change from "D ₃ " to "D ₃ ".	1	.	.	2	.	.	.	3	5	4	6	7	.
-	Almost no shock or slipping in change from "D ₃ " to "D ₄ ".	1	.	.	2	.	.	.	3	5	4	6	7	.
-	Vehicle braked by gear change from "D ₁ " to "D ₃ ".	1	2	4	.	.	.	3	3	.	.
-	Vehicle braked by gear change from "D ₃ " to "D ₃ ".	1	2	.
-	Vehicle braked by gear change from "D ₃ " to "D ₄ ".	1	4	.	.	3	2
-	Maximum speed not attained. Acceleration poor.	1	.	2	5	3	4	11	11	6	7	9	8	.
-	Failure to change gear from "D ₄ " to "D ₃ ".	1	.	.	2	.	.	.	6	4	.	5	.	3	8	.	7	.
-	Failure to change gear from "D ₃ " to "D ₃ " or from "D ₄ " to "D ₃ ".	1	.	.	2	.	.	.	5	3	4	6	7	.	.
-	Failure to change gear from "D ₃ " to "D ₁ " or from "D ₃ " to "D ₁ ".	1	.	.	2	.	.	.	5	3	4	7	.	.	6	.	8	.	.
-	Gear change shock felt during deceleration by releasing accelerator pedal.	.	.	.	1	.	.	.	2	4	.	.	.	3
-	Too high a change point from "D ₄ " to "D ₃ ", from "D ₃ " to "D ₃ ", from "D ₃ " to "D ₁ ".	.	.	.	1	.	2
-	Kickdown does not operate when depressing pedal in "D ₄ " within kickdown vehicle speed.	.	.	.	1	.	2	.	.	.	3	4
-	Kickdown operates or engine overruns when depressing pedal in "D ₄ " beyond kickdown vehicle speed limit.	.	.	.	2	.	1	.	.	.	3	4
-	Races extremely fast or slips in changing from "D ₄ " to "D ₃ " when depressing pedal.	1	.	.	2	.	.	.	3	5	.	4	6	7
-	Races extremely fast or slips in changing from "D ₄ " to "D ₃ " when depressing pedal.	1	.	.	2	.	.	.	3	6	5	.	4	8	.	.	7	.	.
-	Races extremely fast or slips in changing from "D ₃ " to "D ₃ " when depressing pedal.	1	.	.	2	.	.	.	3	5	.	4	.	.	8	.	0	9	7	.	.	6	.	.
-	Races extremely fast or slips in changing from "D ₄ " or "D ₃ " to "D ₁ " when depressing pedal.	1	.	.	2	.	.	.	3	5	.	4	6	7	.	8	.	.
-	Vehicle will not run in any range.	1	2	3	.	.	4	9	5	.	6	.	.	.	8	7	10
-	Transmission noise in "D", "2", "1" and "R" ranges.	1	2

Technical Service Information

A/T Electrical Parts Location

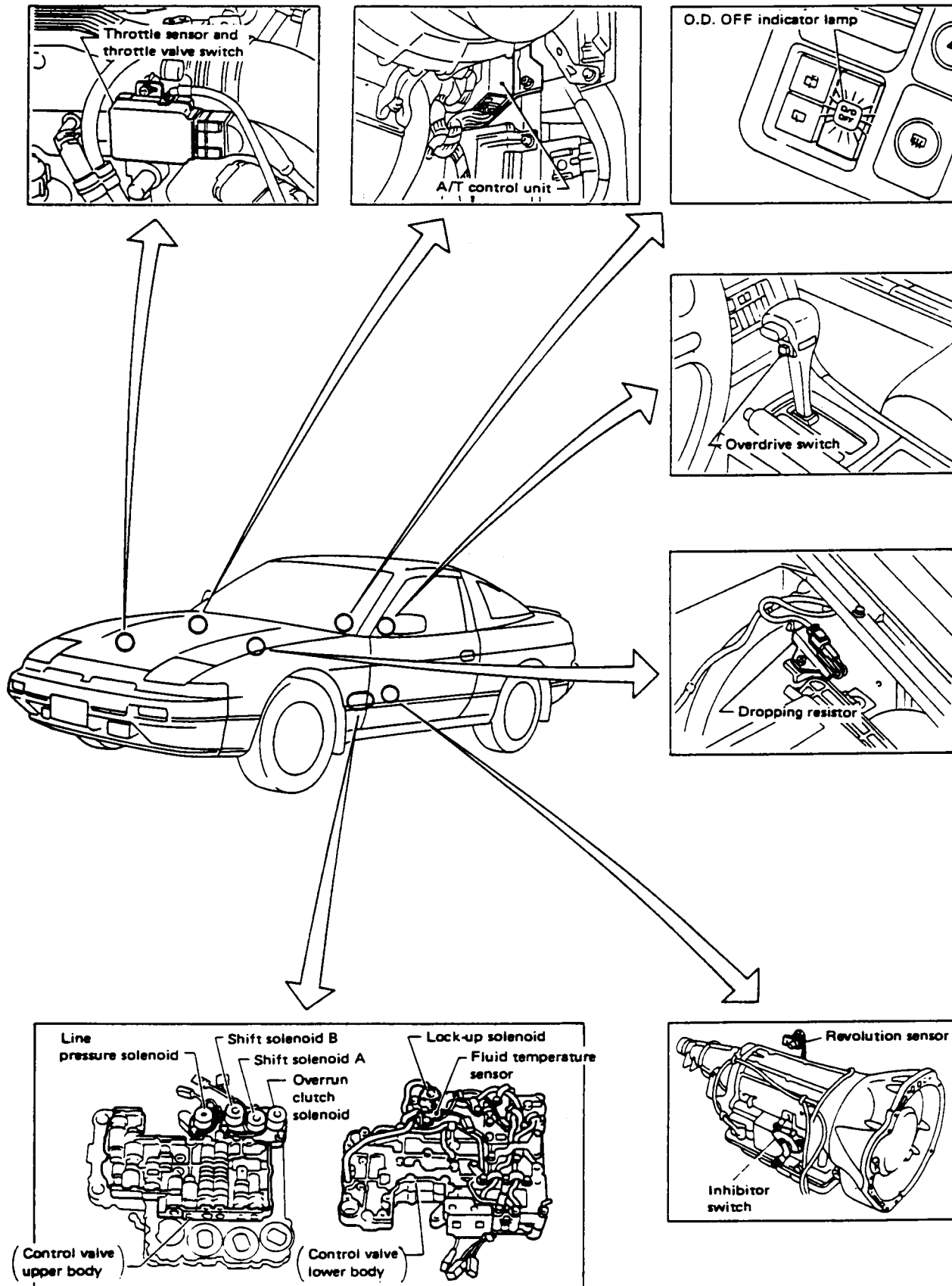

AUTOMATIC TRANSMISSION SERVICE GROUP

Technical Service Information

SHIFT SCHEDULE CONTROL

The transmission gear change points are determined by the automatic transmission control unit after first processing information from various input sensors in conjunction with the control unit memory data on basic gear change points. The control unit then, either energizes or de-energizes shift solenoids A and/or B, thus applying or releasing pilot pressure to shift valves A and/or B.

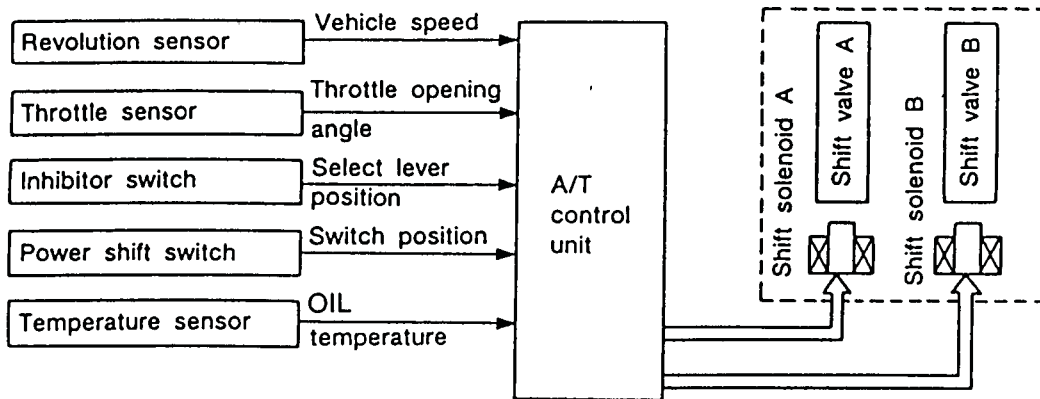

Relationship of Shift Solenoid to Gear Selection

Shift Solenoid	D _{1, 2, 1, 1}	D _{2, 2, 1, 2}	D ₃	D ₄ (OD)	N-P	R
A	ON	OFF	OFF	ON	ON	ON
B	ON	ON	OFF	OFF	ON	ON

NOTE: Gear selection is also relevant to manual valve position.

Shift Solenoid Operation

The shift solenoid performs a simple on/off function. When energized (on), its plunger protrudes blocking the drain on the pilot pressure line. When de-energized (off), the plunger retracts opening the drain on the pilot pressure line.

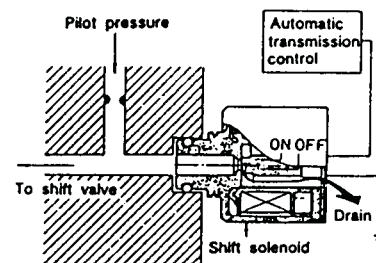

Shift Valves A and B Operation

Pilot pressure, when applied to the shift valve due to the operation of a solenoid valve, acts on the end of the shift valve, overcomes the opposing spring pressure at the other end and the valve moves.

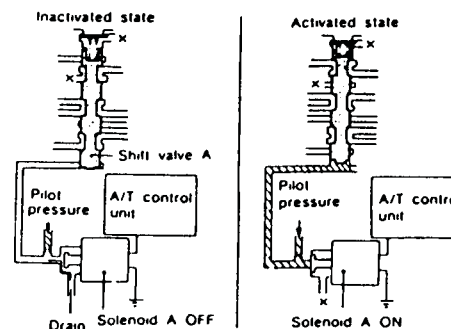

AUTOMATIC TRANSMISSION SERVICE GROUP

Technical Service Information

Wiring Diagram (Cont'd)

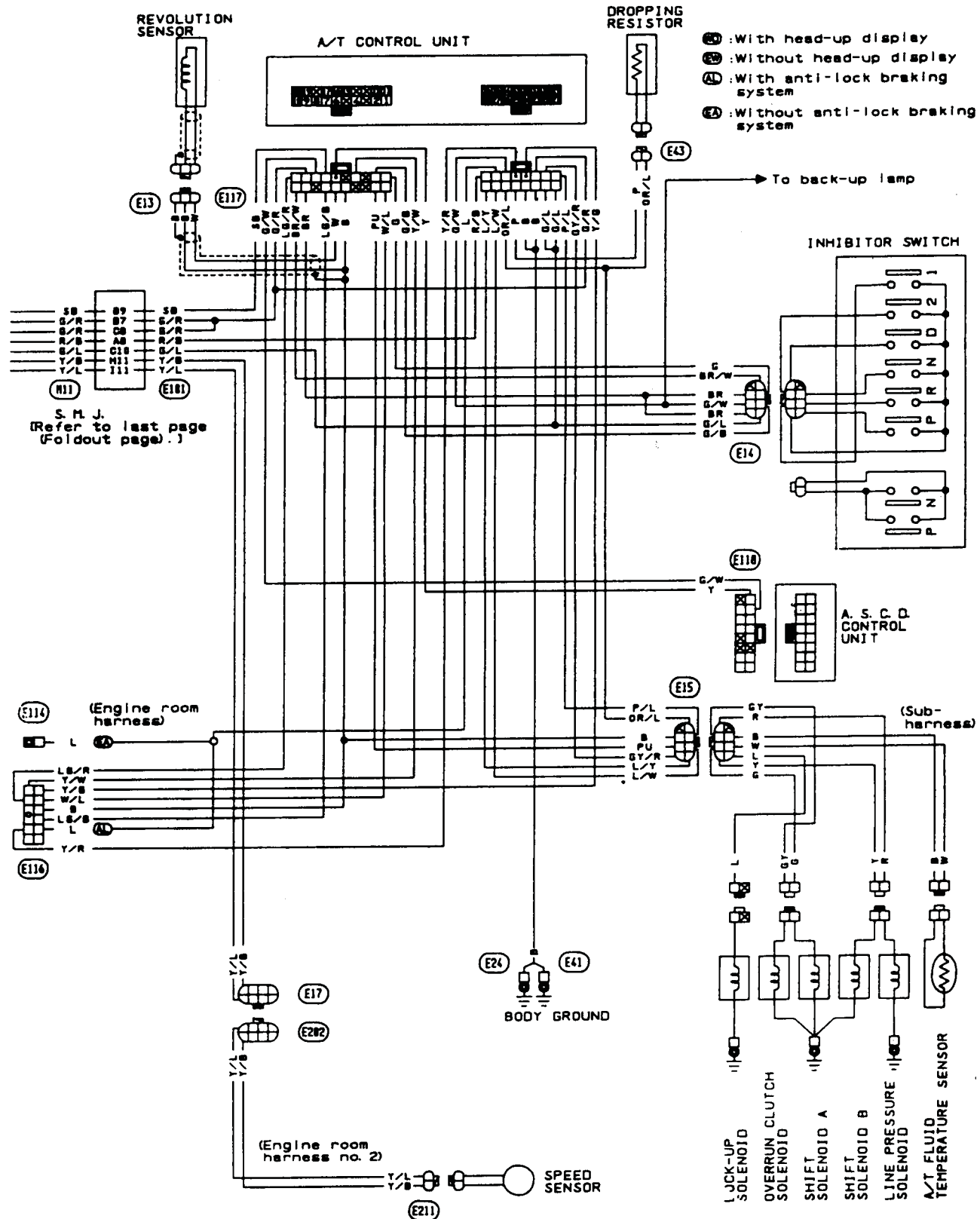

AUTOMATIC TRANSMISSION SERVICE GROUP

Technical Service Information

DISASSEMBLY

Disassembly (Cont'd)

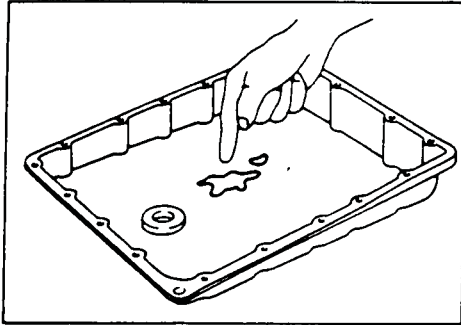

6. Check oil pan and oil strainer for accumulation of foreign particles.
 - If materials of clutch facing are found, clutch plates may be worn.
 - If metal filings are found, clutch plates, brake bands, etc. may be worn.
 - If aluminum filings are found, bushings or aluminum cast parts may be worn.

In above cases, replace torque converter and check unit for cause of particle accumulation.

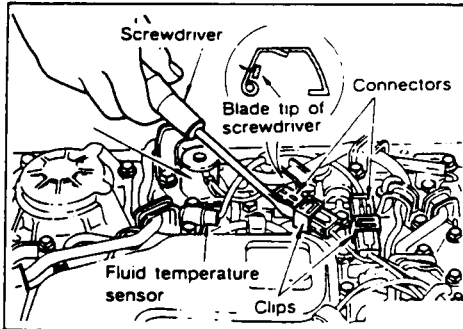

7. Remove lock-up solenoid and fluid temperature sensor connectors.
 - **Be careful not to damage connector.**

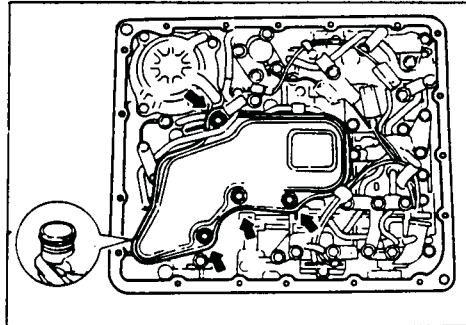

8. Remove oil strainer.
 - a. Remove oil strainer from control valve assembly. Then remove O-ring from oil strainer.

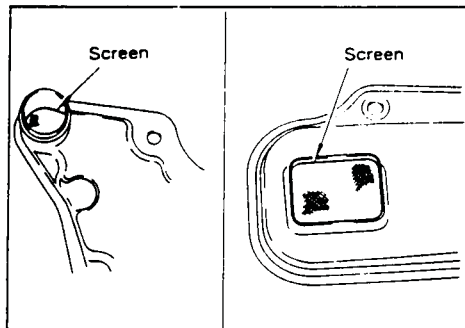

- b. Check oil strainer screen for damage.

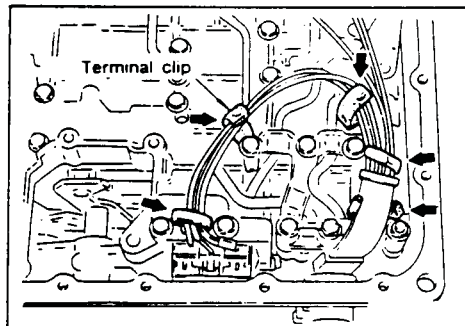

9. Remove control valve assembly.
 - a. Straighten terminal clips to free terminal cords then remove terminal clips.

Technical Service Information

Disassembly (Cont'd)

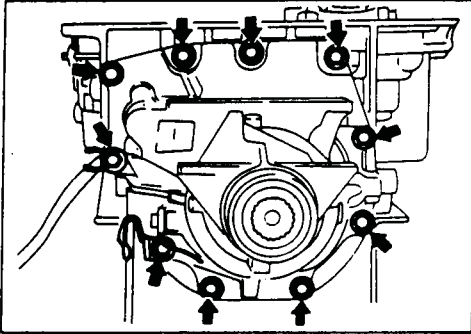

17. Remove rear extension.
 - a. Remove rear extension from transmission case.
 - b. Remove rear extension gasket from transmission case.

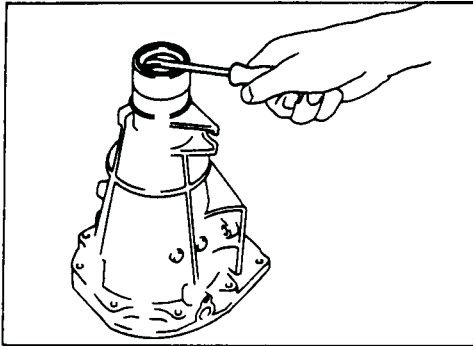

- c. Remove oil seal from rear extension.
 - Do not remove oil seal unless it is to be replaced.

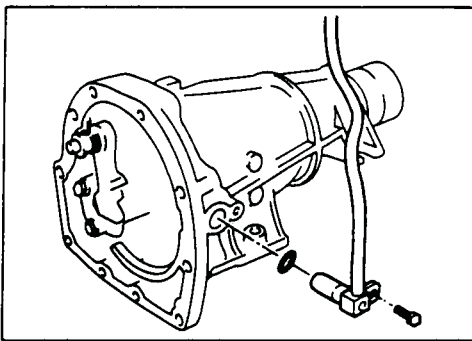

- d. Remove revolution sensor from rear extension.
 - e. Remove O-ring from revolution sensor.

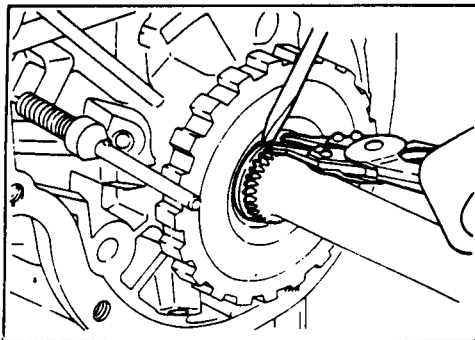

18. Remove output shaft and parking gear.
 - a. Remove rear snap ring from output shaft.

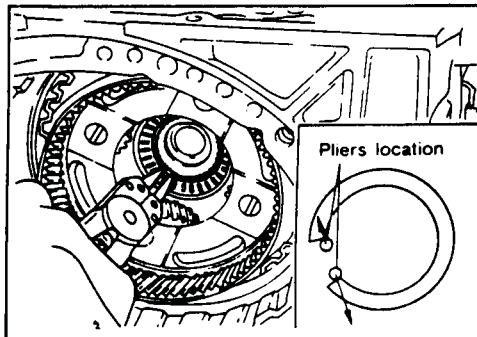

- b. Slowly push output shaft all the way forward.
 - Do not use excessive force.
 - c. Remove snap ring from output shaft.

Technical Service Information

Oil Pump

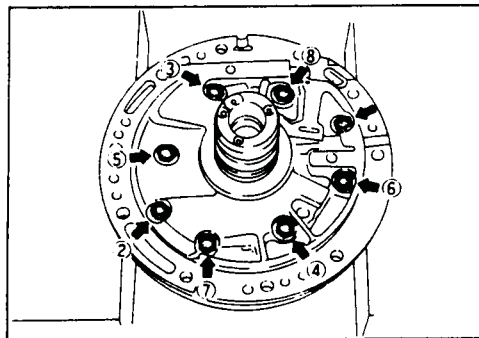
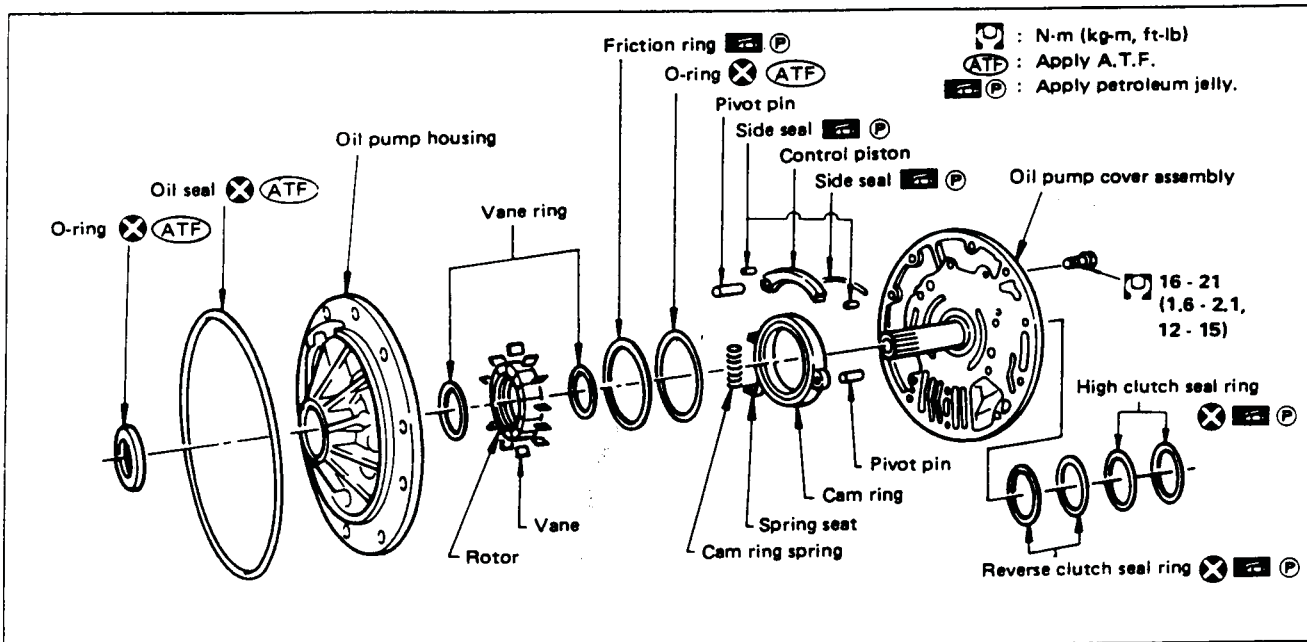

DISASSEMBLY

1. Loosen bolts in numerical order and remove oil pump cover.

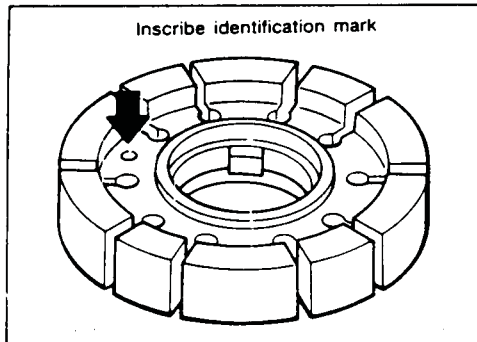

2. Remove rotor, vane rings and vanes.
 - Inscribe a mark on back of rotor for identification of fore-aft direction when reassembling rotor. Then remove rotor.

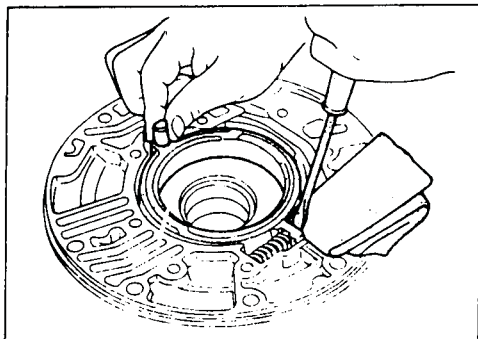

3. While pushing on cam ring remove pivot pin.
 - Be careful not to scratch oil pump housing.

Technical Service Information

Control Valve Assembly

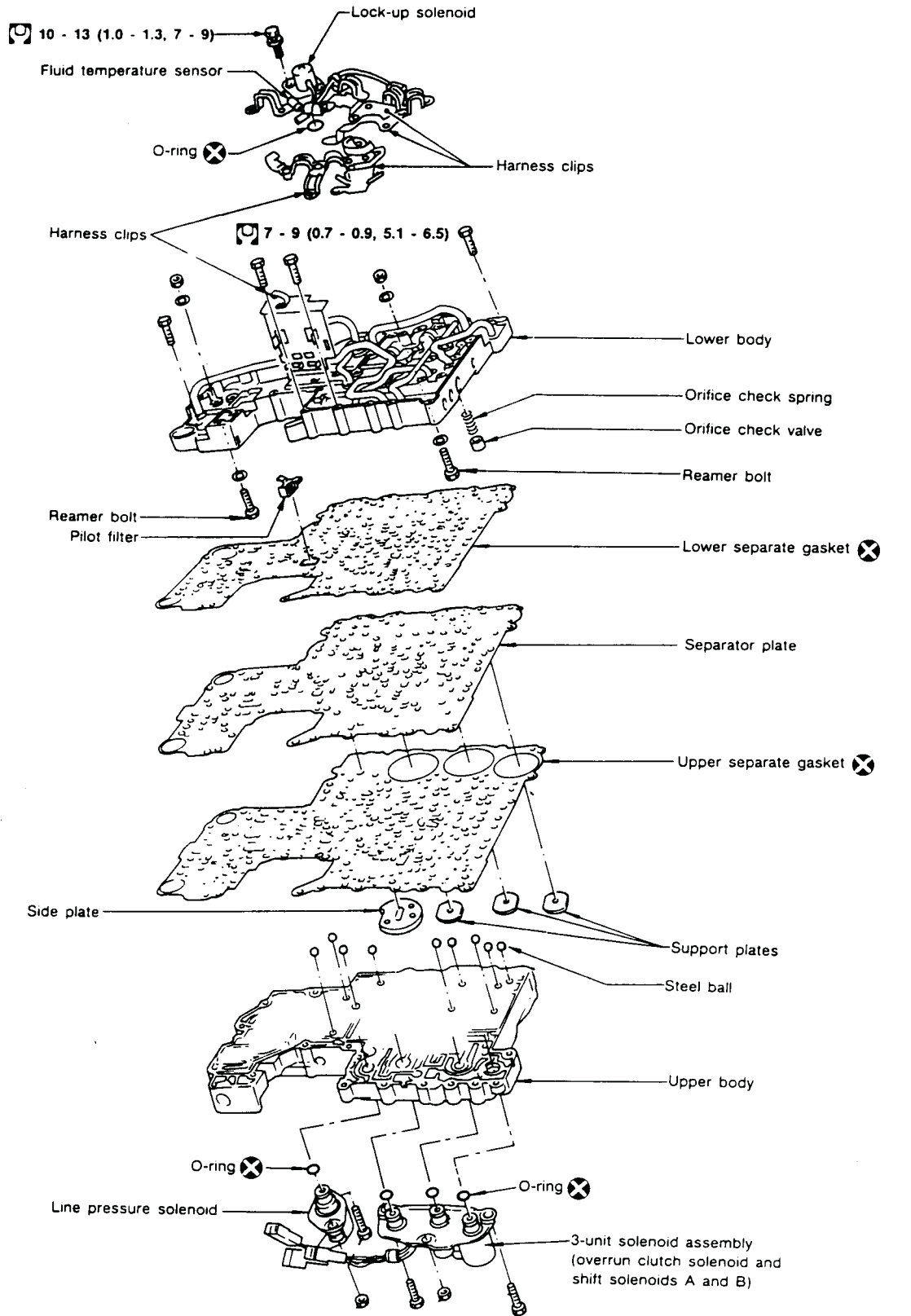

☐ : N·m (kg-m, ft-lb)

AUTOMATIC TRANSMISSION SERVICE GROUP

Technical Service Information

VALVE BODY LAYOUT

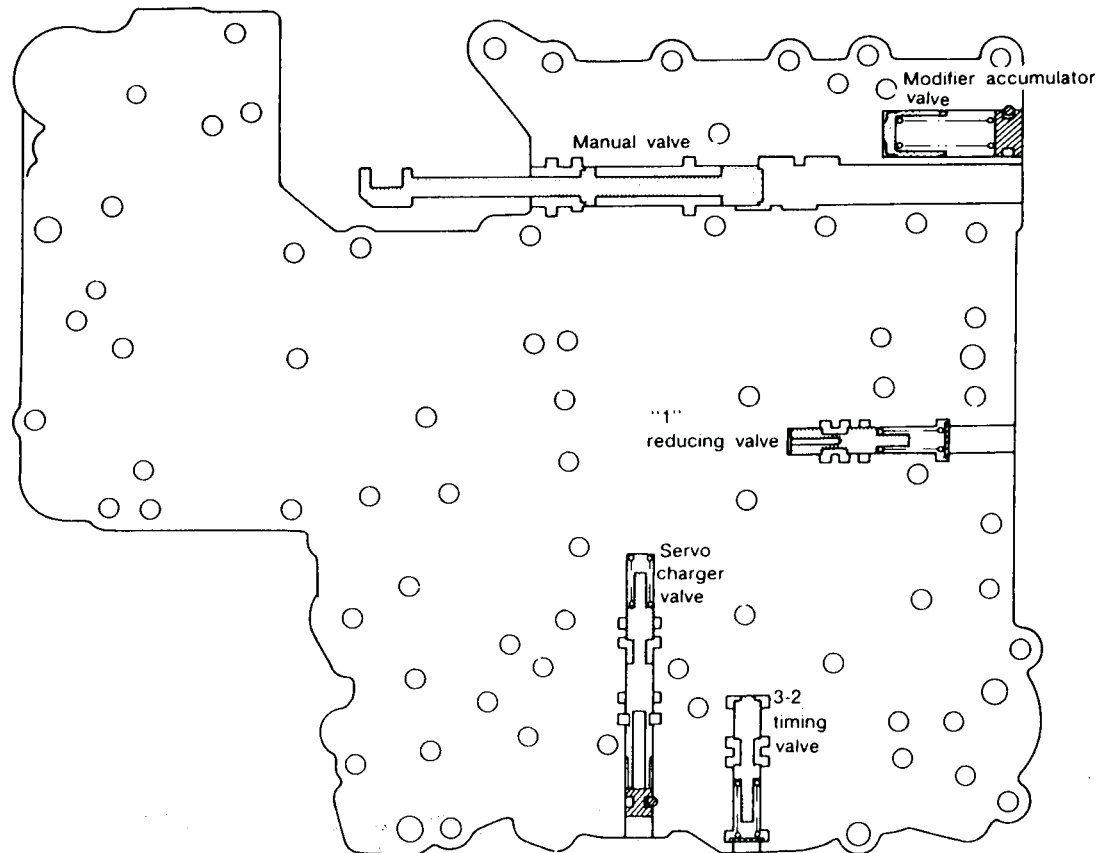
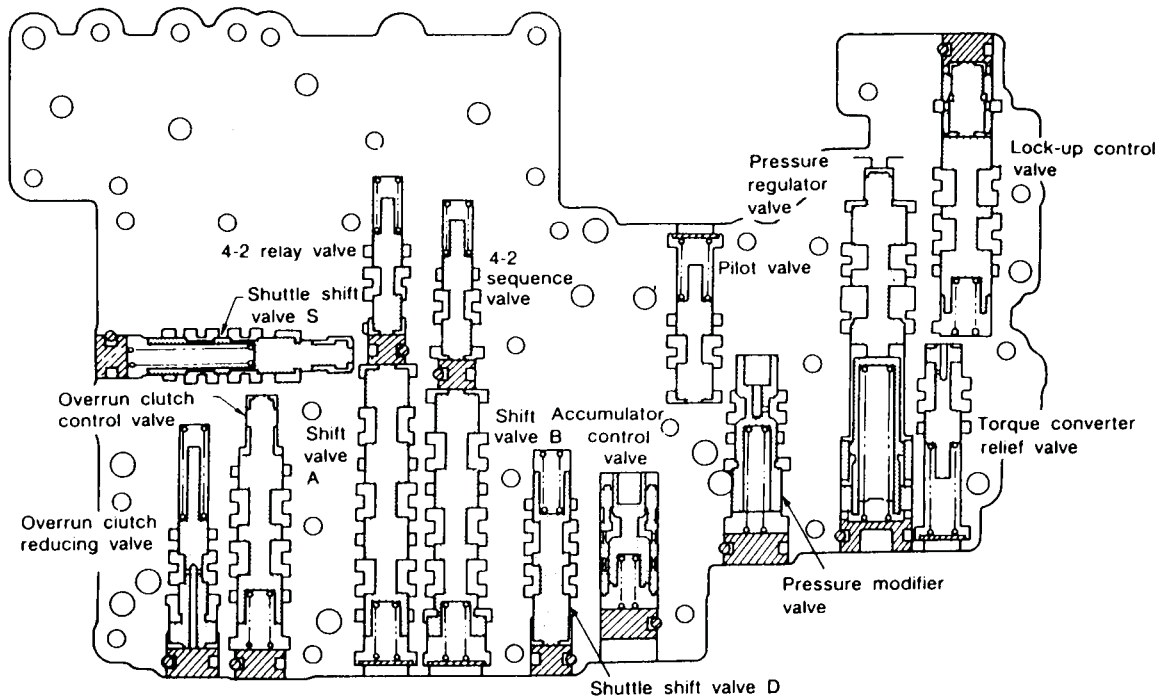

AUTOMATIC TRANSMISSION SERVICE GROUP

Technical Service Information

Forward and Overrun Clutches

For the number of clutch sheets (drive plate and driven plate), refer to the below cross-section.

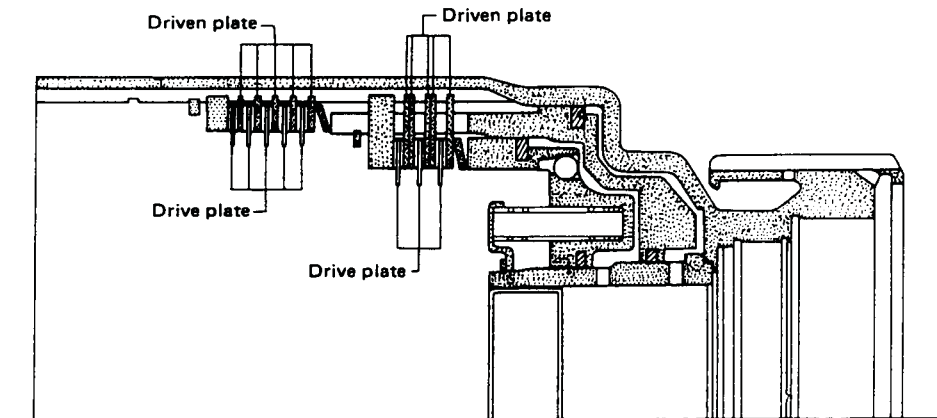
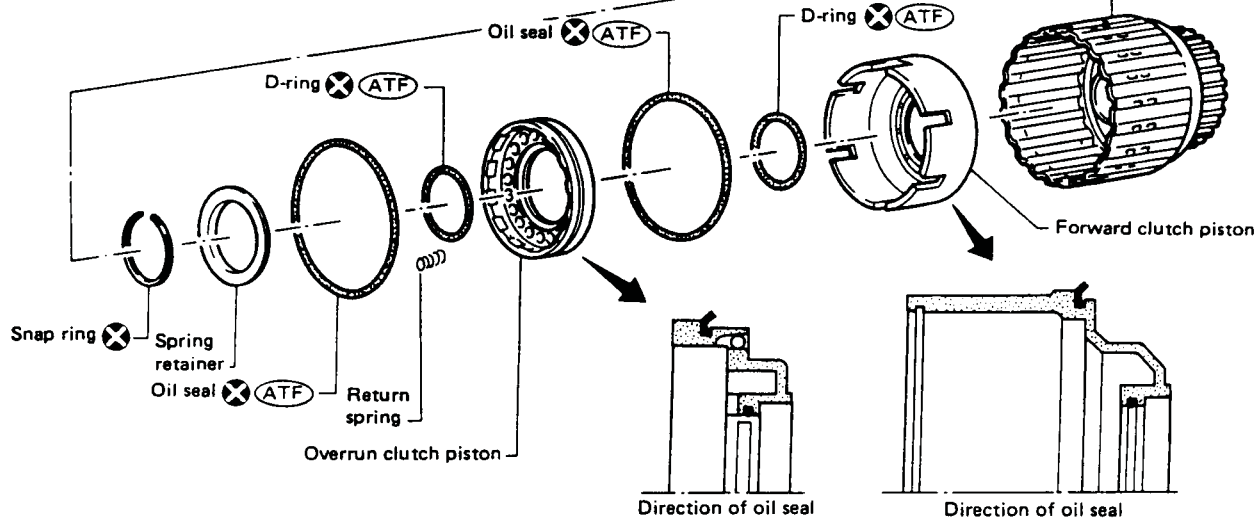
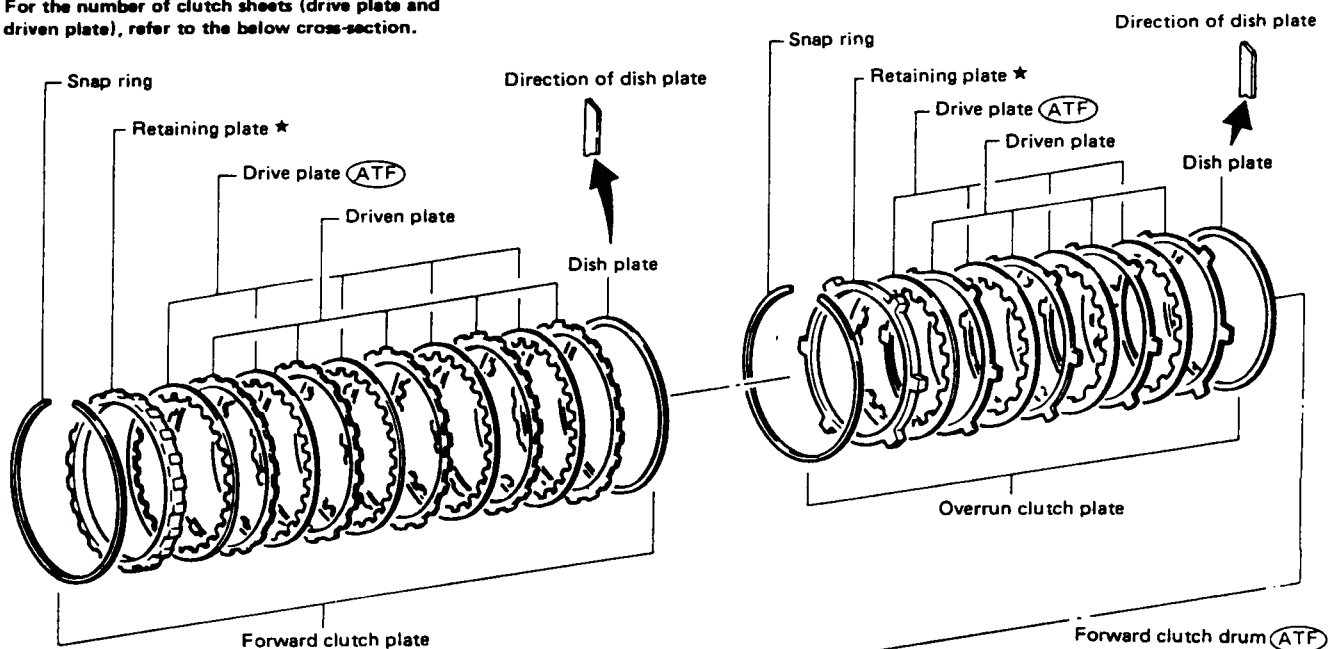

(ATF) : Apply A.T.F.

★ : Select with proper thickness.

Technical Service Information

Forward Clutch Drum Assembly (Cont'd)

4. Remove snap ring from forward clutch drum.

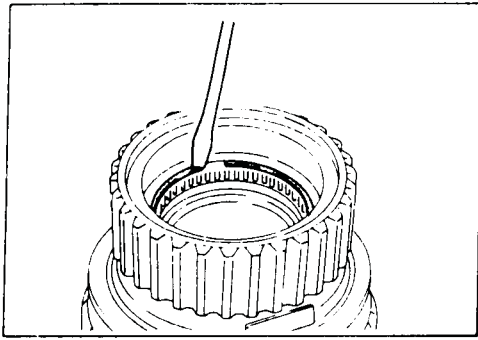

5. Remove needle bearing from forward clutch drum.

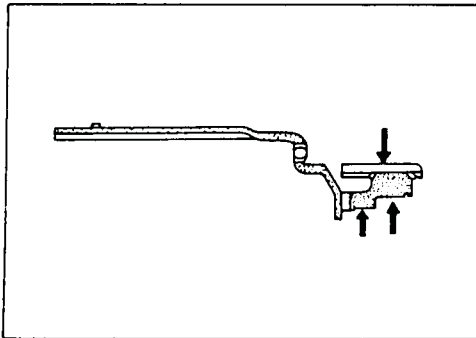
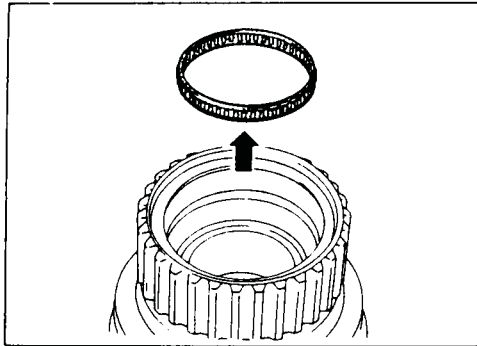

INSPECTION

Forward clutch drum

- Check spline portion for wear or damage.
- Check frictional surfaces of low one-way clutch and needle bearing for wear or damage.

Needle bearing and low one-way clutch

- Check frictional surface for wear or damage.

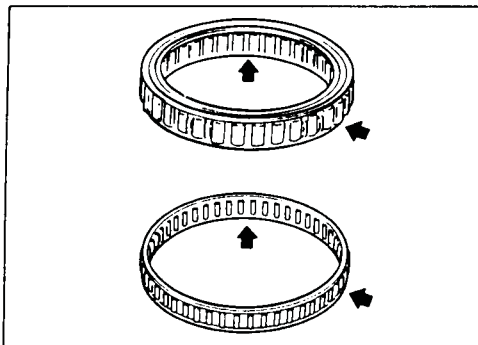

ASSEMBLY

1. Install needle bearing in forward clutch drum.

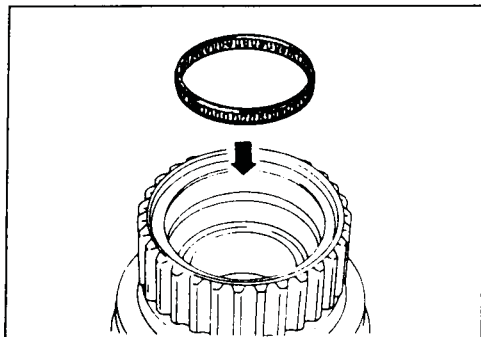

Technical Service Information

Band Servo Piston Assembly (Cont'd)

ASSEMBLY

1. Install O-rings onto servo piston retainer.
 - Apply A.T.F. to O-rings.
 - Pay attention to position of each O-ring.

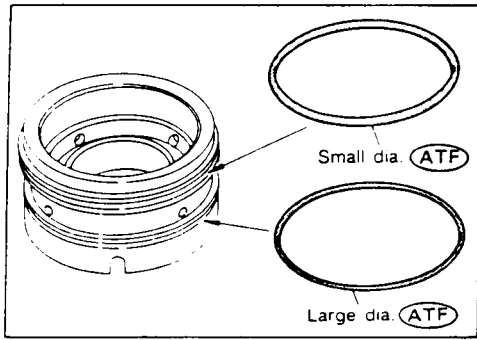

2. Install servo cushion spring retainer onto band servo piston.

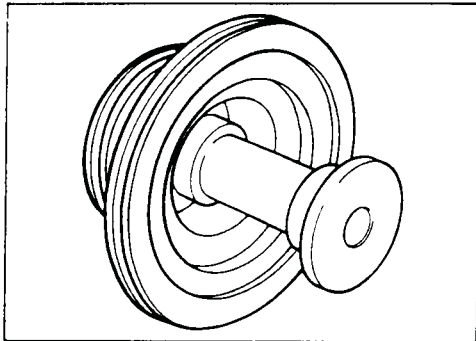

3. Install E-ring onto servo cushion spring retainer.

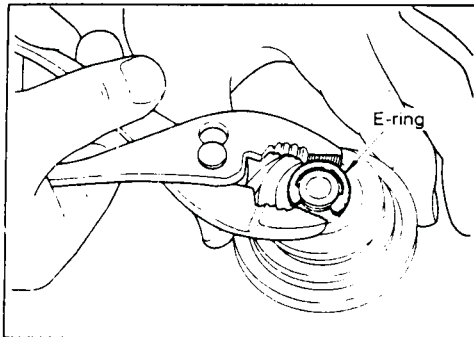

4. Install D-rings onto band servo piston.
 - Apply A.T.F. to D-rings.

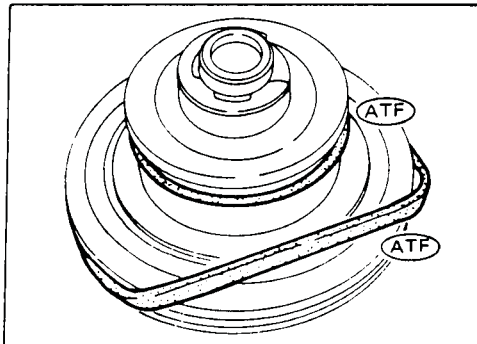

5. Install servo piston spring retainer, return spring C and piston stem onto band servo piston.

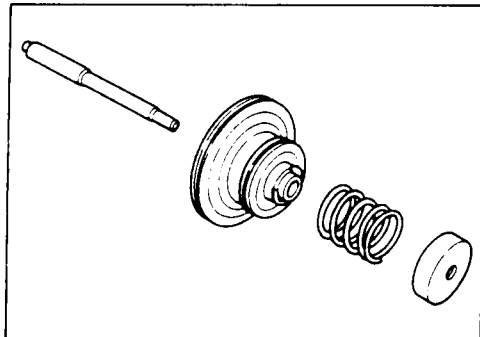

Technical Service Information

Adjustment

When any parts listed in the following table are replaced, total end play or reverse clutch end play must be adjusted.

Part name	Item	Total end play	Reverse clutch end play
Transmission case		●	●
Low one-way clutch inner race		●	●
Overrun clutch hub		●	●
Rear internal gear		●	●
Rear planetary carrier		●	●
Rear sun gear		●	●
Front planetary carrier		●	●
Front sun gear		●	●
High clutch hub		●	●
High clutch drum		●	●
Oil pump cover		●	●
Reverse clutch drum		—	●

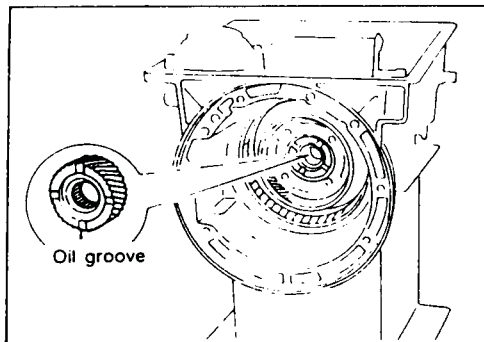

1. Install front side clutch and gear components.
 - a. Install rear sun gear on transmission case.
 - Pay attention to its direction.

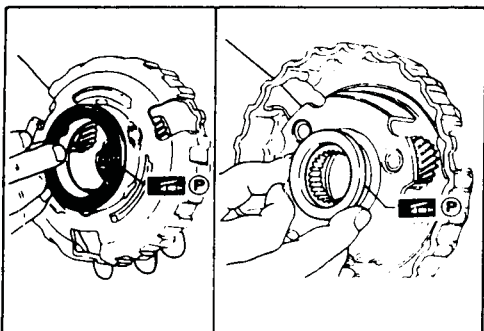

- b. Install needle bearing on front of front planetary carrier.
 - Apply petroleum jelly to needle bearing.
 - c. Install needle bearing on rear of front planetary carrier.
 - Apply petroleum jelly to bearing.
 - Pay attention to its direction — Black side goes to front.

Technical Service Information

Assembly (Cont'd)

Install manual valve on control valve.

- Apply A.T.F. to manual valve.

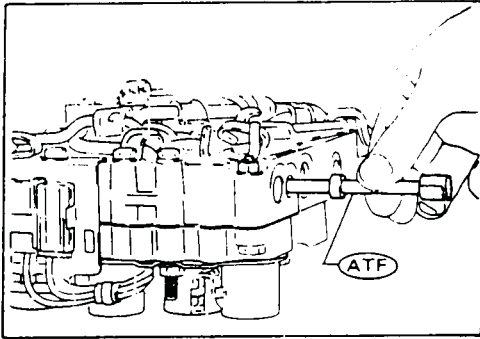

Place control valve assembly on transmission case. Connect solenoid connector for upper body. Install connector clip.

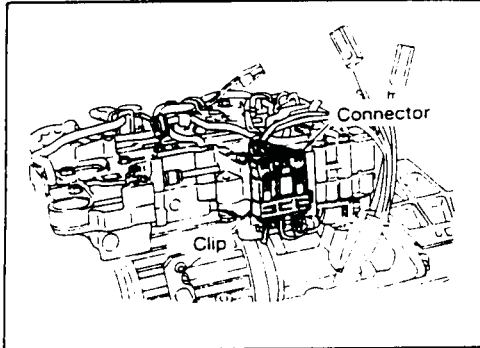

Securely fasten terminal harness with clips.

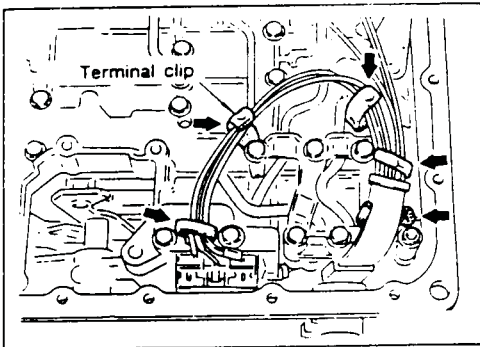

Install lock-up solenoid and fluid temperature sensor connectors.

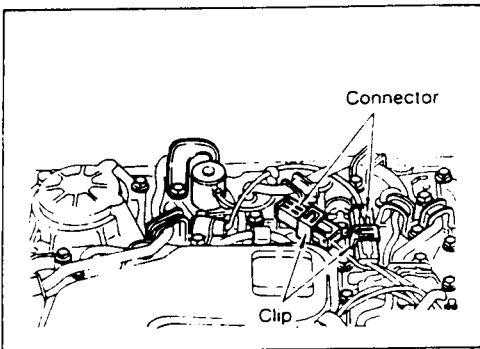

Install oil pan gasket on transmission case.
Install oil pan and bracket on transmission case.

- Tighten four bolts in a criss-cross pattern to prevent dislocation of gasket.

