

FOREWORD

HOW TO USE THIS MANUAL

HOW TO USE THIS MANUAL

To Locate What You Are Looking For:

1. The text of this manual is divided into sections.
2. The section titles are listed on the previous page in a GROUP INDEX. Select the section needed for reference.
3. Find topics easily by using the running headings at the upper outside corners of each page. The primary running heading is the section; the secondary running heading is the subsection.
4. The first page of each section lists a table of contents to easily locate the item and page you need.

POWER UNIT INSTALLATION

INSTALLATION
Installation is reverse order of removal with special attention to the following steps.

CAUTION
Do not re-use gasket removed. Be sure to use new gasket.

INSTALLATION
Install:
Power unit
 Moly Lube
Note:
• Apply Moly Lube to drive shaft splines.
• Rotate the crankshaft to aid alignment of driveshaft and crankshaft splines.

Primary and secondary running headings



Component Parts and Important Item Illustrations

Under the name of each system or unit, an exploded view is provided with work instructions and other service information such as the tightening torque, lubrication and locking agent points.

Example:

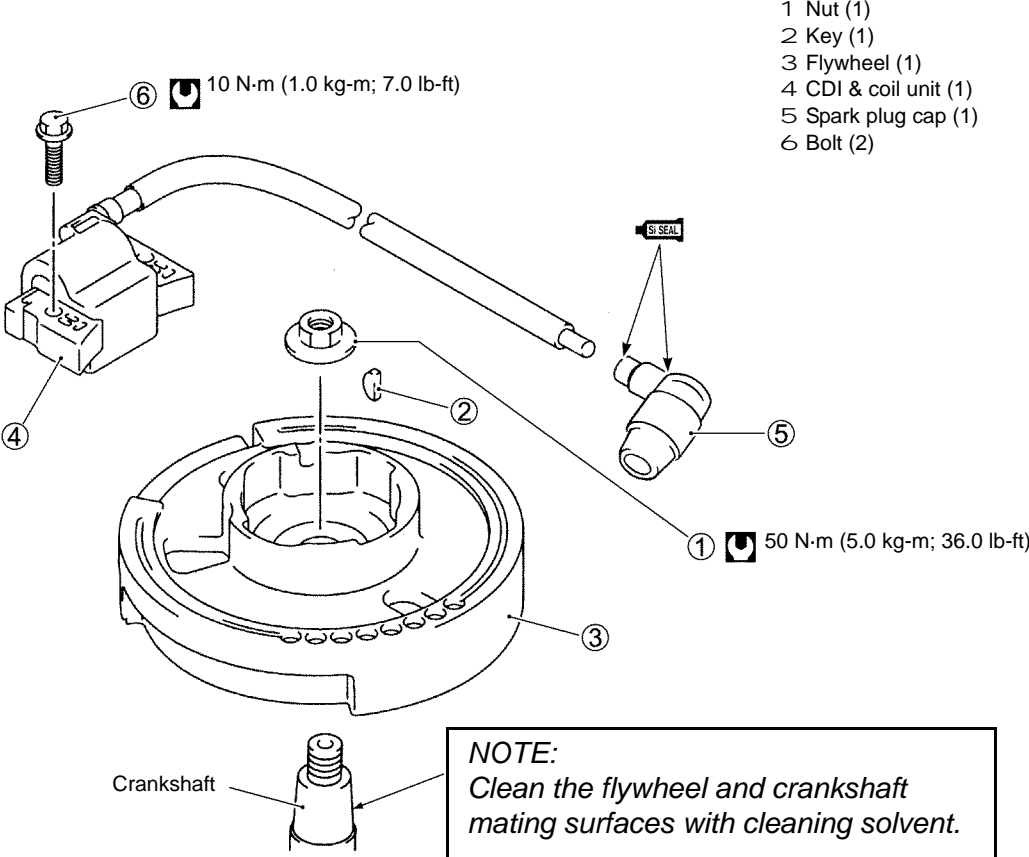

1 Nut (1)
2 Key (1)
3 Flywheel (1)
4 CDI & coil unit (1)
5 Spark plug cap (1)
6 Bolt (2)

10 N-m (1.0 kg-m; 7.0 lb-ft)

50 N-m (5.0 kg-m; 36.0 lb-ft)

SEAL

Crankshaft

NOTE:
Clean the flywheel and crankshaft mating surfaces with cleaning solvent.

GENERAL INFORMATION

WARNING / CAUTION / NOTE

WARNING / CAUTION / NOTE

Please read this manual and follow its instructions carefully. To emphasize special information, the symbol and the words WARNING, CAUTION and NOTE have special meanings. Pay special attention to the messages highlighted by these signal words.

⚠ WARNING

Indicates a potential hazard that could result in death or injury.

⚠ CAUTION

Indicates a potential hazard that could result in motor damage.

NOTE:

Indicates special information to make maintenance easier or instructions clearer.

Please note, however, that the warnings and cautions contained in this manual cannot possibly cover all potential hazards relating to the servicing, or lack of servicing, of the outboard motor. In addition to the WARNING and CAUTION stated, you must also use good judgement and observe basic mechanical safety principles.

GENERAL PRECAUTIONS

⚠ WARNING

- Proper service and repair procedures are important for the safety of the service mechanic and the safety and reliability of the outboard motor.
- To avoid eye injury, always wear protective goggles when filing metals, working on a grinder, or doing other work, which could cause flying material particles.
- When 2 or more persons work together, pay attention to the safety of each other.
- When it is necessary to run the outboard motor indoors, make sure that exhaust gas is vented outdoors.
- When testing an outboard motor in the water and on a boat, ensure that the necessary safety equipment is on board. Such equipment includes: flotation aids for each person, fire extinguisher, distress signals, anchor, paddles, bilge pump, first-aid kit, emergency starter rope, etc.
- When working with toxic or flammable materials, make sure that the area you work in is well-ventilated and that you follow all of the material manufacturer's instructions.
- Never use gasoline as a cleaning solvent.
- To avoid getting burned, do not touch the engine, engine oil or exhaust system during or shortly after engine operation.
- Oil can be hazardous. Children and pets may be harmed from contact with oil. Keep new and used oil away from children and pets. To minimize your exposure to oil, wear a long sleeve shirt and moisture-proof gloves (such as dishwashing gloves) when changing oil. If oil contacts your skin, wash thoroughly with soap and water. Launder any clothing or rags if wet with oil. Recycle or properly dispose of used oil.
- After servicing fuel, oil/engine cooling system and exhaust system, check all lines and fittings related to the system for leaks.
- Carefully adhere to the battery handling instructions laid out by the battery supplier.

GENERAL INFORMATION
*SPECIFICATIONS

Item	Unit	Data		
		4 HP	5 HP	6 HP

POWERHEAD







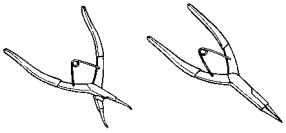
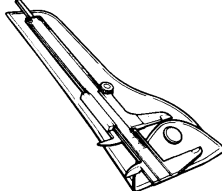
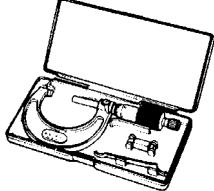
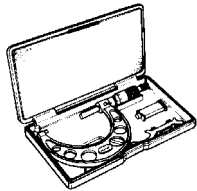
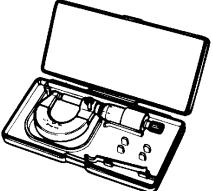
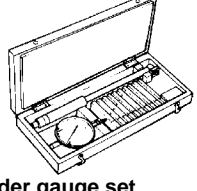
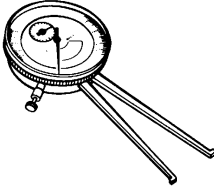
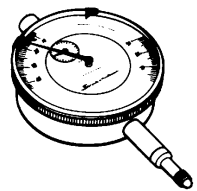
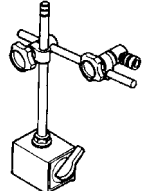
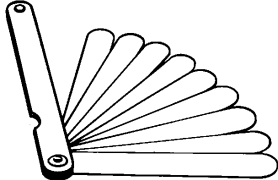
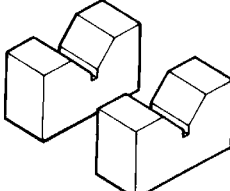

Recommended operating range	r/min	4000 – 5000	4500 – 5500	4750 – 5750
Idle speed	r/min	1300 ± 50 (in-gear: approx: 1150)		1300 ± 50 (in-gear: approx: 1200)
*Cylinder compression (with decompression system)	kPa (kg/cm ² , psi)	550 – 650 (5.5 – 6.5; 78 – 92)		
Engine oil		<i>Ultra Four Stroke Oil</i> or Viscosity rating 10W-40, API classification SE, SF, SG, SH, SJ		
BREAK-IN OIL (FIRST 10 HOURS)		<i>Evinrude/Johnson Four Stroke Oil</i>		
Engine oil amounts	l (US/Imp. qt)	0.7 (0.74/0.62)		
Thermostat operating temperature	°C (°F)	48 – 52 (118 – 126)		

* Figures shown are guidelines only, not absolute service limits.

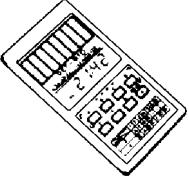
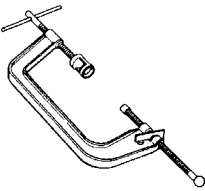
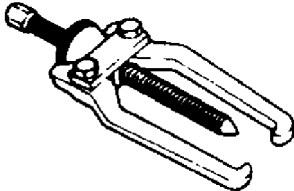
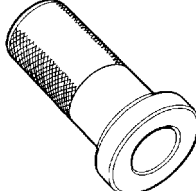
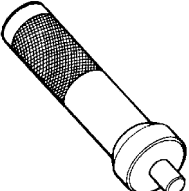
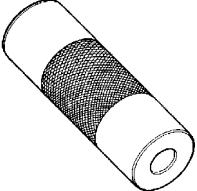
CARBURETOR

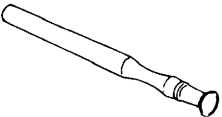
Type		KEIHIN BC19-3.5	KEIHIN BC19-3.5	KEIHIN BC21-15
I.D mark		91J80	91J90	91JB0
Main jet	#	70		78
Pilot jet	#	35		38
Pilot screw	Turns open	PRE-SET		
Float height	mm	10 ± 1		

SPECIAL TOOLS

<p>1.</p>  <p>Snap ring pliers</p>	<p>2.</p>  <p>Vernier calipers</p>	<p>3.</p>  <p>Micrometer (25 – 50 mm)</p>	<p>4.</p>  <p>Micrometer (50 – 75 mm)</p>
<p>5.</p>  <p>Micrometer (0 – 25 mm)</p>	<p>6.</p>  <p>Cylinder gauge set (40 – 80 mm)</p>	<p>7.</p>  <p>Dial calipers (10 – 34 mm)</p>	<p>8.</p>  <p>Dial gauge</p>
<p>9.</p>  <p>Magnetic stand</p>	<p>10.</p>  <p>Thickness gauge</p>	<p>11.</p>  <p>Steel "V" block set</p>	<p>12.</p>  <p>(0,025 – 0,076 mm) Plastigauge</p>
<p>13.</p>  <p>Engine tachometer</p>	<p>14.</p>  <p>Valve lifter</p>	<p>15.</p>  <p>Flywheel remover</p>	<p>16.</p>  <p>Remover and installer</p>
<p>17.</p>  <p>Remover and installer</p>	<p>18.</p>  <p>Remover and installer</p>	<p>19.</p>  <p>Compression gauge 12mm Adaptor</p>	<p>20.</p>  <p>Valve lapper</p>
<p>21.</p>  <p>Valve lifter attachment</p>	<p>22.</p>  <p>Valve seat cutter (Neway 121)</p>	<p>23.</p>  <p>Valve seat cutter (Neway 122)</p>	<p>24.</p>  <p>Gear oil filler</p>

4. Measure the valve clearance by inserting thickness gauge between the valve stem end and the rocker arm.



Thickness gauge

Valve clearance (cold engine condition):

IN 0.03 – 0.07 mm (0.001 – 0.003 in)

EX 0.03 – 0.07 mm (0.001 – 0.003 in)

If the valve clearance is out of the specification, adjust the clearance.

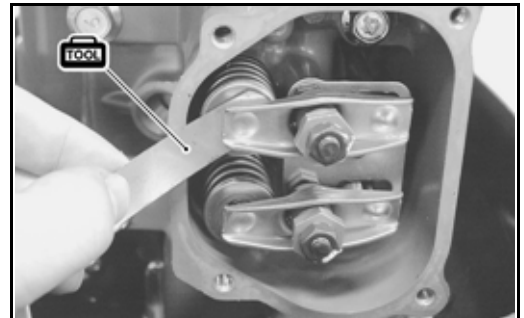
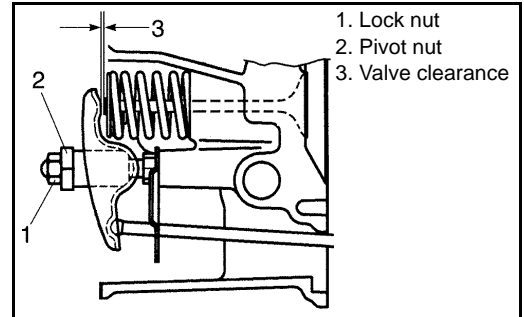

Adjustment

5. Loosen the valve adjusting lock nut 1 while holding the pivot nut 2.
6. Turn the pivot nut 2 to bring the valve clearance to within the specification.



Thickness gauge

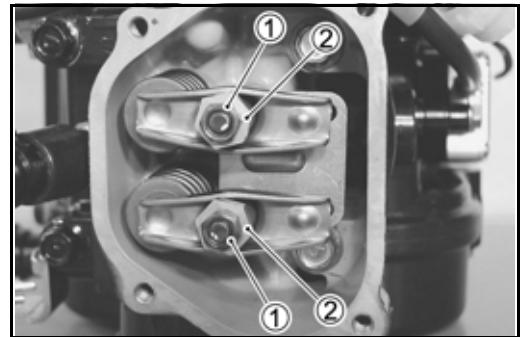

7. Tighten the lock nut 1 to the specified torque while holding the pivot nut 2.



Valve adjusting lock nut: 11 N·m (1.1 kg·m; 8.0 lb·ft)

8. Recheck the valve clearance.

Installation

Installation is reverse order of removal with the special attention to the following steps.

- Tighten the four cylinder head cover bolts diagonally to the specified torque.



Cylinder head cover bolt: 8 N·m (0.8 kg·m; 6.0 lb·ft)

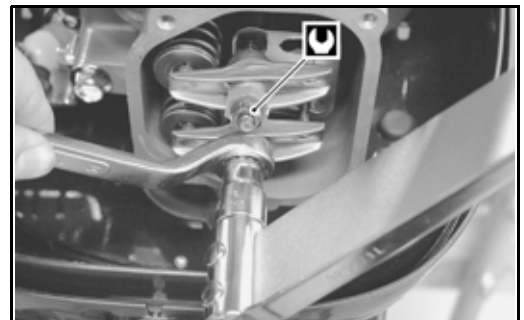

CAUTION

Do not re-use the gasket once removed. Always use a new gasket.

- Make sure that the cylinder head cover gasket is installed correctly. (See page 6-39)

INSPECTION

Ignition Secondary Coil Resistance

Measure the secondary coil resistance in the CDI and coil unit.

 **Digital Voltmeter**

 **Tester range: Ω (Resistance)**

1. Remove the spark plug cap from the high-tension cord.
2. Measure the secondary coil resistance.

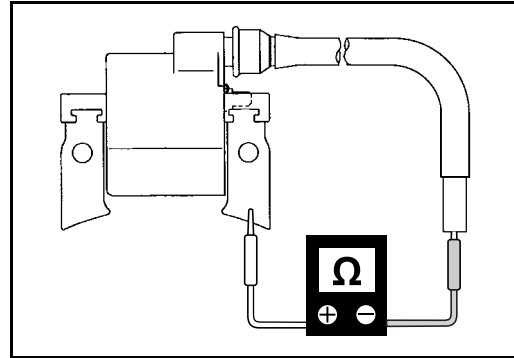

Tester probe connection	
Probe	Other probe
High-tension cord	Core

Ignition secondary coil resistance: 8.2 – 12.4 kΩ

If the measurement is out of the specification, replace the CDI and coil unit.

Spark Plug Cap

 **Digital Voltmeter**

 **Tester range: Ω (Resistance)**

Measure the spark plug cap resistance.

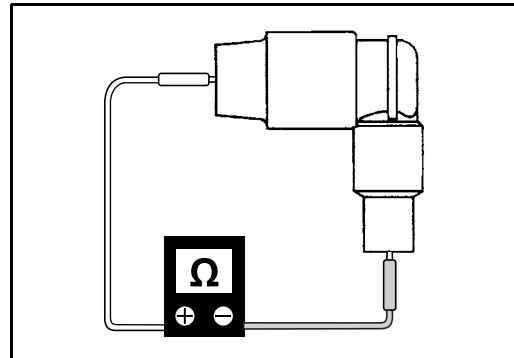

Tester probe connection	
Probe	Other probe
Cap end	Other cap end

Spark plug cap resistance: 7.5 – 12.5 kΩ

If the measurement is out of the specification, replace the spark plug cap.

CLEANING AND INSPECTION

Clean thoroughly with cleaning solvent and compressed air before inspection.

⚠ WARNING

Wear safety glasses when using compressed air to expel solvent, carburetor cleaner etc.

⚠ CAUTION

Do not place any rubber, plastic or non-metallic parts in cleaning solvent, as severe damage or deterioration will result.

⚠ CAUTION

Do not use a wire or a small drill bit in order to clean the orifices and jets of the carburetor.

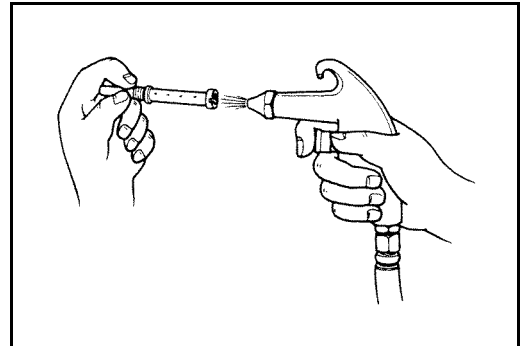

CARBURETOR BODY / FLOAT CHAMBER

Inspect the carburetor body and the float chamber. If crack or other damage is found, replace the body and/or the chamber.

Clean the carburetor body and the float chamber in order to remove obstructions.



JET / NOZZLE

Inspect the jets and the nozzle. If crack or other damage is found, replace the jet and/or the nozzle.

Clean the jets and the nozzle in order to remove obstructions.

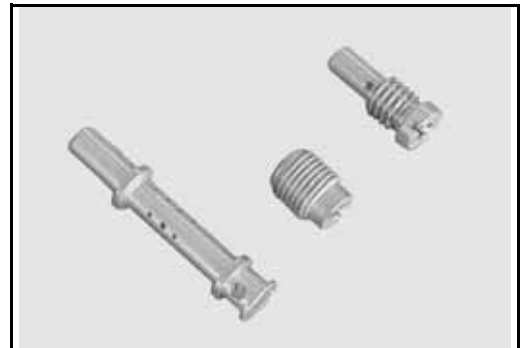

Inspection

Fuel connector

Inspect the fuel connector and the connector plug. If leakage, deterioration or other damage is found, replace the connector and/or the plug.

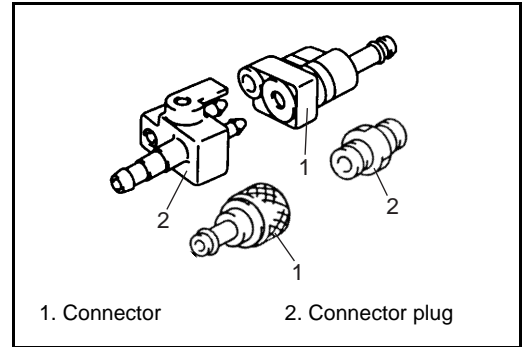

Fuel primer bulb

Inspect the fuel primer bulb. If crack, leakage or deterioration is found, replace the bulb.

If the check valve function is defective, replace the bulb.

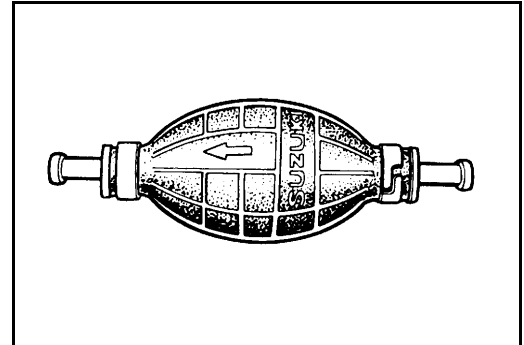

Fuel hose

Inspect the fuel hoses. If cut, crack, leakage, abrasion, tear or deterioration is found, replace the hoses.

Fuel cock

Inspect the fuel cock. If leakage, deterioration or other damage is found, replace the cock.

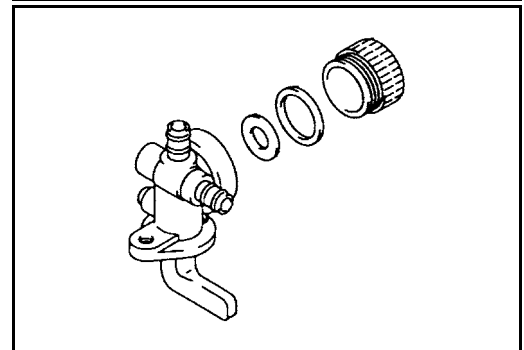

Fuel tank

Inspect the fuel tank. If crack, leakage or deterioration is found, replace the tank.

If water or other contamination is found, drain and clean the tank.

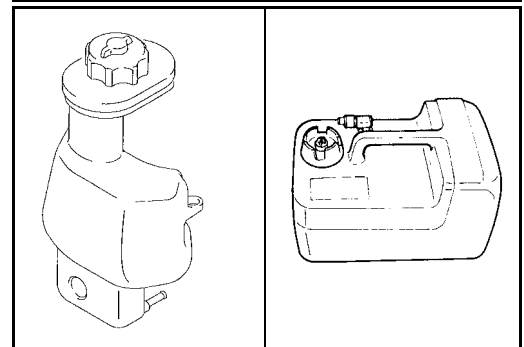

Tank cap

Check that the fuel tank vent opens and relieves internal tank pressure properly.

If vent is suspect, replace the tank cap.

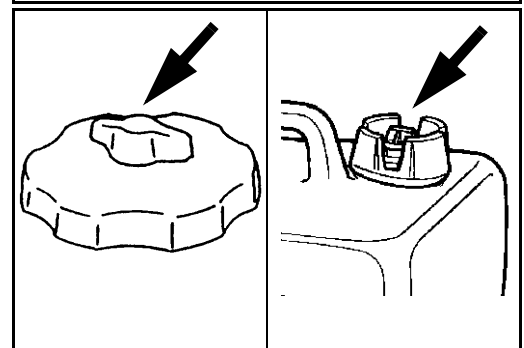

NEUTRAL START INTERLOCK (NSI)

ADJUSTMENT

1. Shift into "NEUTRAL" position.
2. Adjust and tighten the lock nuts 1 as shown position.
3. Loosen the adjustment nuts 2.
4. Adjust the nuts 2 until the center of the reel stopper 3 aligns with the arrow mark a .
5. Tighten the nuts 2.
6. Pull the recoil starter and make sure that the starter does not work when the shift lever 4 is in "FORWARD" and "REVERSE" position.
7. Apply *Triple-Guard* grease to the inner cable, the clutch notch plate 5 and the reel stopper 3.

 **Triple-Guard** grease

CAUTION

If the NSI cable is removed or left without correct adjustment, there is a high risk of losing one's balance and/or being thrown overboard if the motor starts in gear.

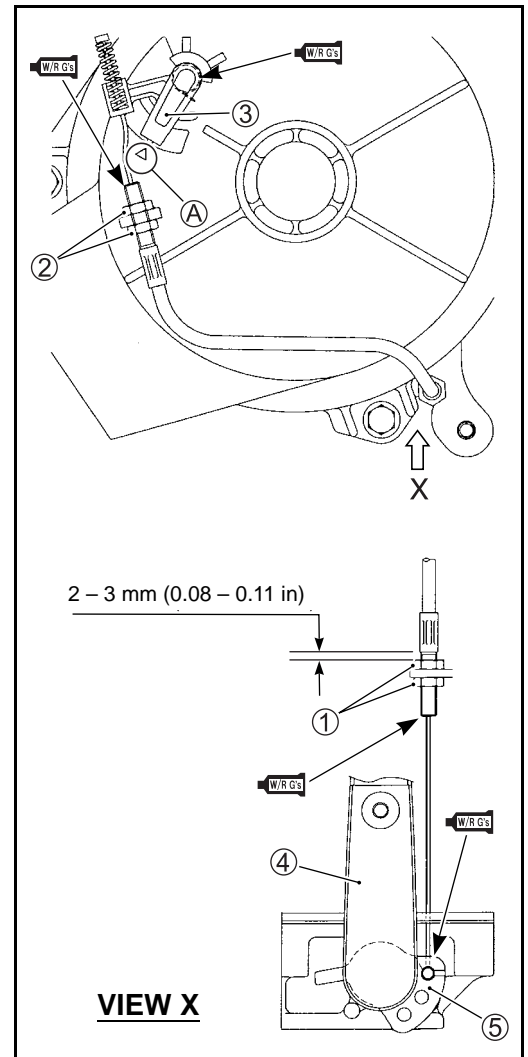

CYLINDER / PISTON / CRANKSHAFT / CONROD / CAMSHAFT

1. Loosen the six crankcase bolts in the order indicated and remove the bolts.

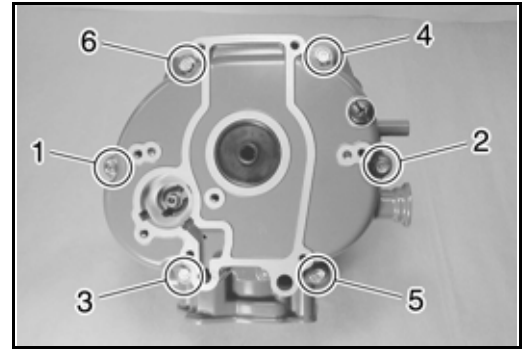

2. Remove the crankcase from the cylinder block.

NOTE:

Pry the crankcase with a screwdriver as shown in the figure.

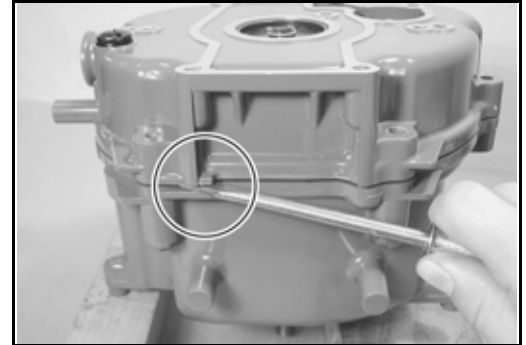

3. Remove the crankshaft thrust washer 1 and the camshaft thrust washer 2.
4. Remove the camshaft 3 from the cylinder block.

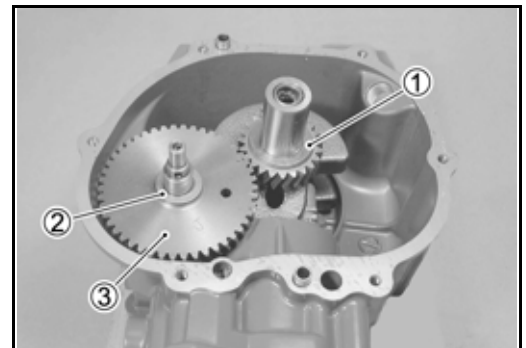

5. Remove the two tappets 4.

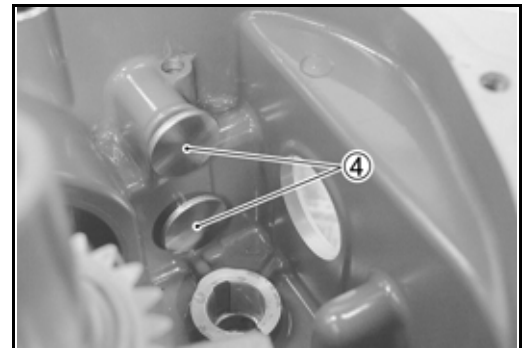

6. Remove the two conrod bolts 5 and the conrod cap 6.

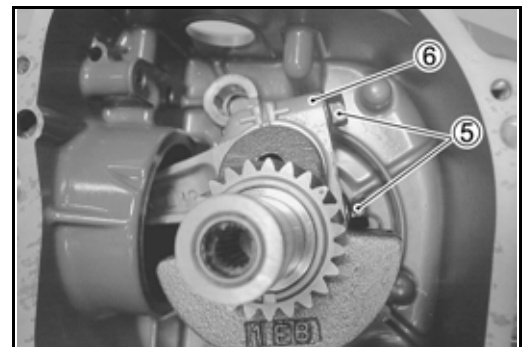

POWERHEAD VALVE SPRING

5. Ream the valve guide bore with the 5.5 mm reamer.

 **Valve guide reamer ($\phi 5,5$ mm)**
Reamer handle

NOTE:

Clean and oil the valve guide bore after reaming.

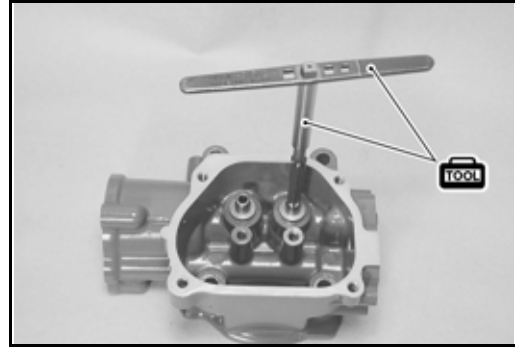

VALVE SPRING

Valve spring free length

Measure the valve spring free length.

 **Vernier calipers**

Valve spring free length:

Standard: IN and EX 29.5 mm (1.16 in)

Service limit: IN and EX 28.3 mm (1.11 in)

If the measurement exceeds the service limit, replace the valve spring.

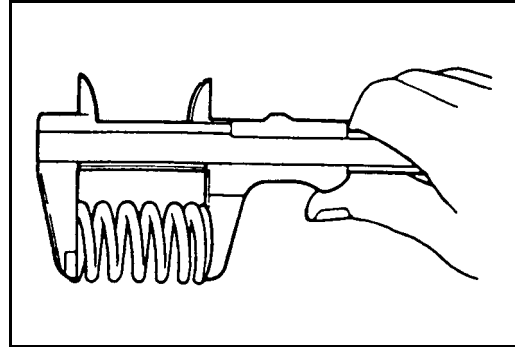

Valve spring preload

Measure the valve spring preload.

 **Vernier calipers**

Valve spring preload:

Standard:

IN and EX 139 – 159 N (13.9 – 15.9 kg, 30.6 – 35.1 lbs) for 19.3 mm (0.76 in)

Service limit:

IN and EX 127 N (12.7 kg, 28.0 lbs) for 19.3 mm (0.76 in)

If the measurement exceeds the service limit, replace the valve spring.

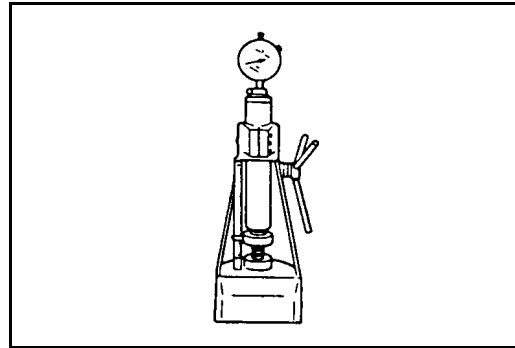

Conrod big end oil clearance

Check the clearance as follows.

1. Clean the surface of the conrod, the conrod cap and the crank pin.
2. Place a piece of the Plastigage on the crank pin parallel to the crankshaft, avoiding the oil hole.

 **Plastigage**

3. Install the conrod and the conrod cap to the crank pin.
4. Install the two conrod bolts and tighten the bolts to the specified torque in two steps.

NOTE:

Do not rotate the conrod with the Plastigage in place.

 **Conrod bolt:**

1st step 10 N·m (1.0 kg·m, 7.0 lb-ft)
2nd step 20 N·m (2.0 kg·m, 14.5 lb-ft)

5. Remove the conrod and the conrod cap from the crank pin.
6. Using the scale on the Plastigage envelope, measure the Plastigage with the widest point.

Conrod big end oil clearance:

Standard: 0.015 – 0.035 mm (0.0006 – 0.0014 in)

Service limit: 0.080 mm (0.0031 in)

If the measurement exceeds the service limit, replace the conrod assembly and/or crankshaft.

Conrod big end inside diameter:

Standard: 28.015 – 28.025 mm (1.1030 – 1.1033 in)

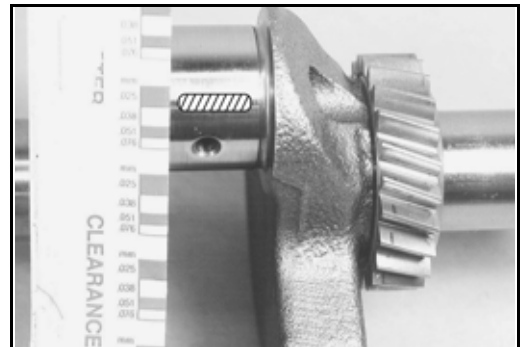
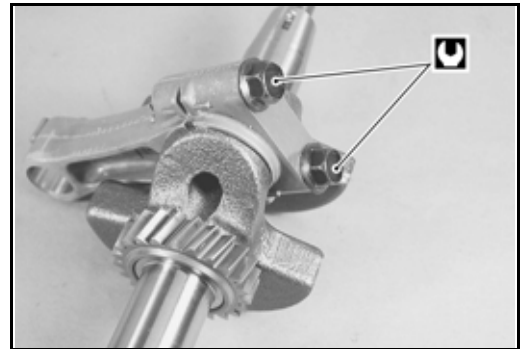
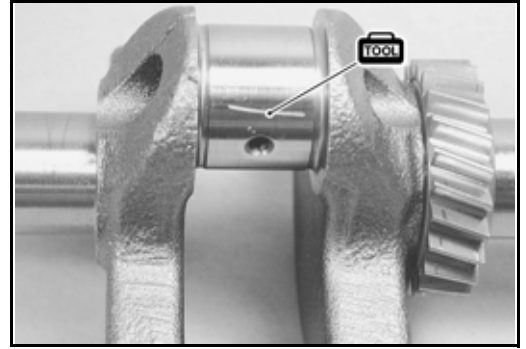

POWERHEAD REASSEMBLY

Camshaft to Cylinder

1. Apply engine oil to the tappets.
2. Install the tappets in the cylinder block.
3. Apply engine oil to the cam faces and the cam journals.
4. While aligning each punch mark on the camshaft gear and the crankshaft gear, install the camshaft to the cylinder block.

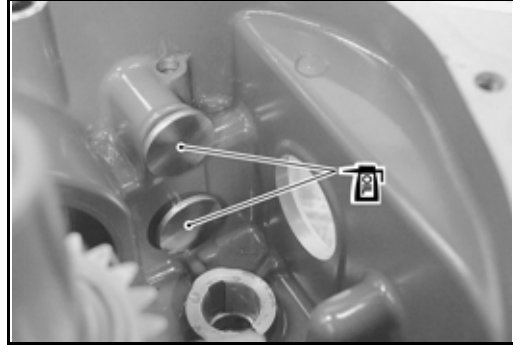

Crankcase to Cylinder

1. Clean the mating surfaces of the cylinder block and the crankcase.
2. Install the two dowel pins in the cylinder block.
3. Install new gasket.
4. Install the crankcase on the cylinder block.
5. Tighten the six crankcase bolts to the specified torque in the order indicated.

 **Crankcase bolt: 10 N·m (1.0 kg·m; 7.0 lb-ft)**

NOTE:

Do not apply engine oil to the crankcase bolts.

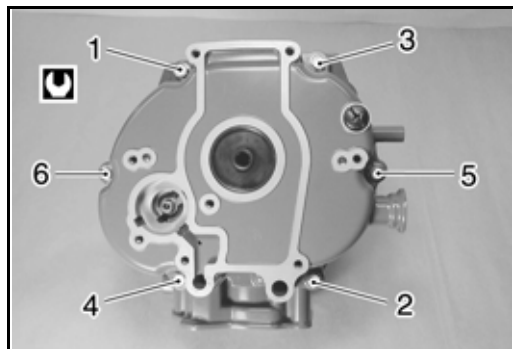
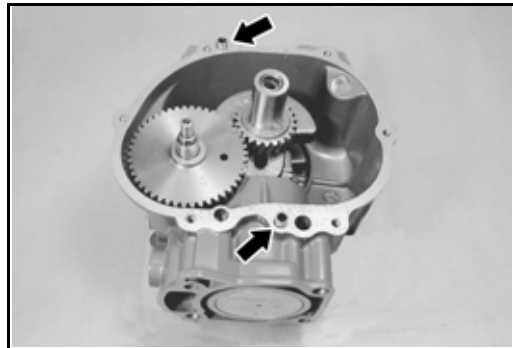

TILLER HANDLE

Removal / Installation

REMOVAL

1. Remove the throttle cable from the carburetor and the intake manifold.
2. Remove the lead wires / cable binder, then take out the throttle control cable from the lower cover.
(See page 6-3)
3. Remove the engine stop switch from the tiller handle.
4. Remove the pivot nut and the washer.
5. Remove the pivot bolt.
6. Remove the tiller handle from the steering bracket.
7. Remove the two bushings.

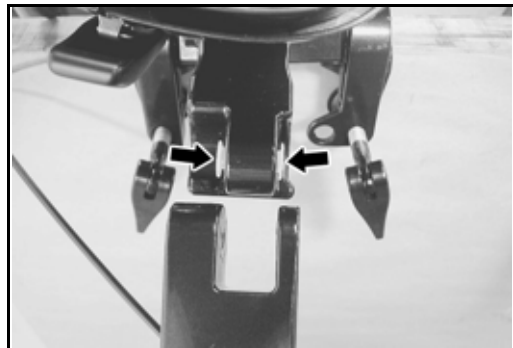
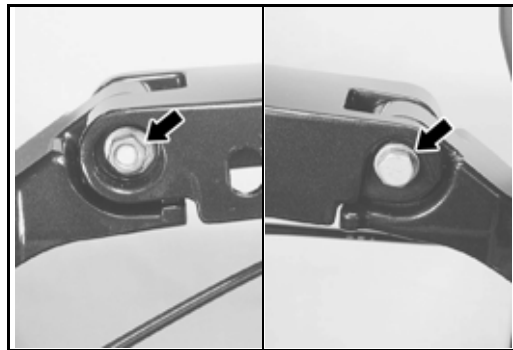
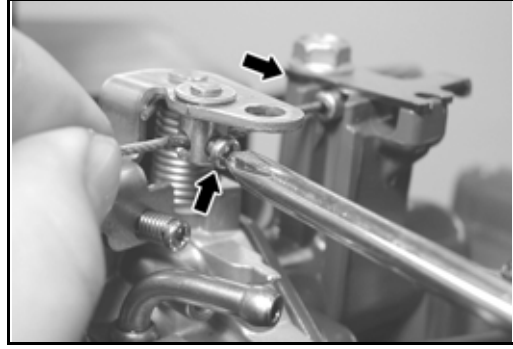

MIDSECTION

STEERING BRACKET / DRIVESHAFT HOUSING / SWIVEL BRACKET / CLAMP BRACKET

Swivel Bracket / Clamp Bracket

⚠ CAUTION

Do not re-use the cotter pin once removed. Always use a new cotter pin.

- Apply *Triple-Guard* grease to the clamp bracket bushings.

Triple-Guard grease

- Tighten the clamp bracket shaft nut to the specified torque.

Clamp bracket shaft nut: 25 N-m (2.5 kg-m; 18.0 lb-ft)

- Apply *Nut Lock* to the clamp bracket lower rod nut.

Nut Lock

Driveshaft Housing / Steering Bracket

- Apply *Triple-Guard* grease to the following parts:

- Inside and outside surfaces of the bushings
- Inside surface of the lower mount
- Steering adjuster

Triple-Guard grease

- Install the upper mount and the lower mount positioned as shown in the figure.

