

## Identification Number Description

### Vehicle Identification Number

<b>K</b>	<b>M</b>	<b>H</b>	<b>F</b>	<b>H</b>	<b>4</b>	<b>D</b>	<b>G</b>	<b>1</b>	<b>C</b>	<b>A</b>	<b>000001</b>
1	2	3	4	5	6	7	8	9	10		

#### 1. World Manufacturer Identifier (WMI)

- KMF : Commercial vehicle (Van)
- KMH : Passenger vehicle or MPV(Multipurpose Passenger Vehicle)/SUV(Sports Utility Vehicle)/RV(Recreational Vehicle)
- KMJ : Van
- KM8 : MPV/SUV/RV (For U.S.A, Canada, Mexico only)

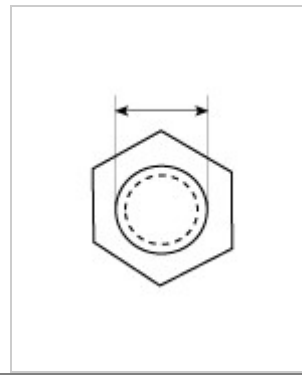
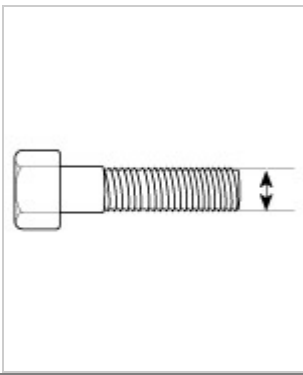

BOLT/NUT Thin screw		Torque Nm (kg.m, lb-ft)		
Nominal diameter. (mm)	Pitch [mm (in.) ]	4T	8T	10T
M5	0.8 (0.031)	2.0 ~ 3.0 (0.2 ~ 0.3, 1.4 ~ 2.2)	4.9 ~ 6.9 (0.5 ~ 0.7, 3.6 ~ 5.1)	7.8 ~ 10.8 (0.8 ~ 1.1, 5.8 ~ 8.0)
M6	1 (0.039)	2.9 ~ 4.9 (0.3 ~ 0.5, 2.2 ~ 3.6)	8.8 ~ 12.7 (0.9 ~ 1.3, 6.5 ~ 9.4)	13.7 ~ 18.6 (1.4 ~ 1.9, 10.1 ~ 13.7)
M8	1.25 (0.049)	8.8 ~ 11.8 (0.9 ~ 1.2, 6.5 ~ 8.7)	22.6 ~ 30.4 (2.3 ~ 3.1, 16.6 ~ 22.4)	33.3 ~ 44.1 (3.4 ~ 4.5, 24.6 ~ 32.5)
M10	1.5 (0.059)	16.7 ~ 22.6 (1.7 ~ 2.3, 12.3 ~ 16.6)	45.1 ~ 60.8 (4.6 ~ 6.2, 33.3 ~ 44.8)	65.7 ~ 88.3 (6.7 ~ 9.0, 48.5 ~ 65.1)
M12	1.75 (0.068)	29.4 ~ 39.2 (3.0 ~ 4.0, 21.7 ~ 28.9)	78.5 ~ 105.9 (8.0 ~ 10.8, 57.9 ~ 78.1)	114.7 ~ 154.9 (11.7 ~ 15.8, 84.6 ~ 114.3)
M14	2 (0.078)	47.1 ~ 63.7 (4.8 ~ 6.5, 34.7 ~ 47.0)	125.5 ~ 169.7 (12.8 ~ 17.3, 92.6 ~ 125.1)	183.4 ~ 249.1 (18.7 ~ 25.4, 135.3 ~ 183.7)
M16	2 (0.078)	73.5 ~ 100.0 (7.5 ~ 10.2, 54.2 ~ 73.8)	197.1 ~ 266.7 (20.1 ~ 27.2, 145.4 ~ 196.7)	288.3 ~ 390.3 (29.4 ~ 39.8, 212.7 ~ 287.9)
M20	2.5 (0.098)	144.2 ~ 195.2 (14.7 ~ 19.9, 106.3 ~ 143.9)	396.2 ~ 535.4 (40.4 ~ 54.6, 292.2 ~ 394.9)	565.8 ~ 764.9 (57.7 ~ 78.0, 417.3 ~ 564.2)
M24	3 (0.118)	249.1 ~ 337.3 (25.4 ~ 34.4, 183.7 ~ 248.8)	687.4 ~ 929.7 (70.1 ~ 94.8, 507.0 ~ 685.7)	975.8 ~ 1320.0 (99.5 ~ 134.6, 719.7 ~ 973.6)
M30	3.5 (0.137)	499.2 ~ 674.7 (50.9 ~ 68.8, 368.2 ~ 497.6)	1372.9 ~ 1858.4 (140.0 ~ 189.5, 1012.6 ~ 1370.7)	1956.4 ~ 2647.8 (199.5 ~ 270.0, 1443.0 ~ 1952.9)

BOLT/NUT Thin screw		Torque Nm (kg.m, lb-ft)		
Nominal diameter. (mm)	Pitch [mm (in.) ]	4T	8T	10T
M5	0.5 (0.019)	2.0 ~ 3.0 (0.2 ~ 0.3, 1.4 ~ 2.2)	5.9 ~ 8.8 (0.6 ~ 0.9, 4.3 ~ 6.5)	8.8 ~ 12.7 (0.9 ~ 1.3, 6.5 ~ 9.4)
M6	0.75 (0.029)	3.9 ~ 4.9 (0.4 ~ 0.5, 2.9 ~ 3.6)	9.8 ~ 13.7 (1.0 ~ 1.4, 7.2 ~ 10.1)	14.7 ~ 20.6 (1.5 ~ 2.1, 10.8 ~ 15.2)
M8	1 (0.039)			

(2) Remove the ground bolt (B).

(3) Remove the engine wirings from the engine room.

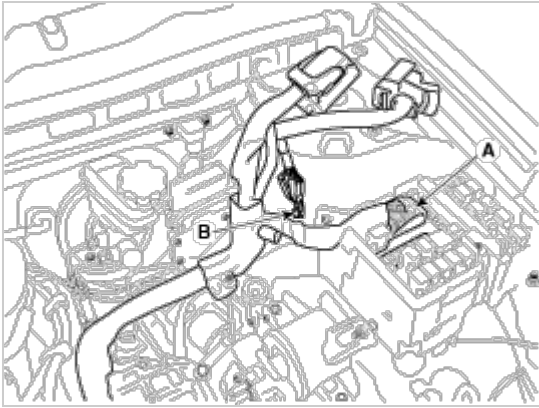

13. Remove the transaxle wire harness connectors and control cable from the transaxle.  
(Refer to Automatic Transaxle System - "Automatic Transaxle")

14. Loosen the bolt & nut and then disconnect the lower arm (A) from the front knuckle.

---

**Tightening Torque :**

98.1~117.7N.m (10.0~12.0kgf.m, 72.3 ~ 86.6lb-ft)

---

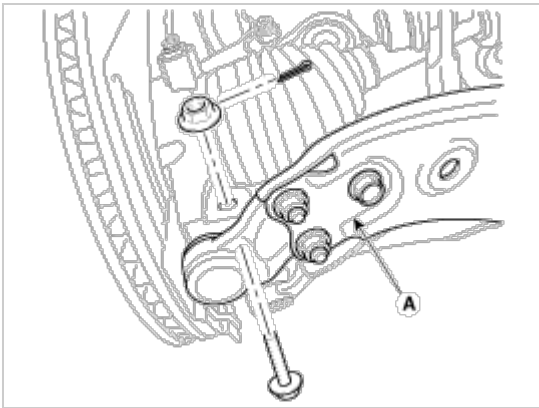

15. Remove the front stabilizer bar links (A).

---

**Tightening Torque :**

98.1~117.7N.m(10.0~12.0kgf.m, 72.3~86.8lb-ft)

---

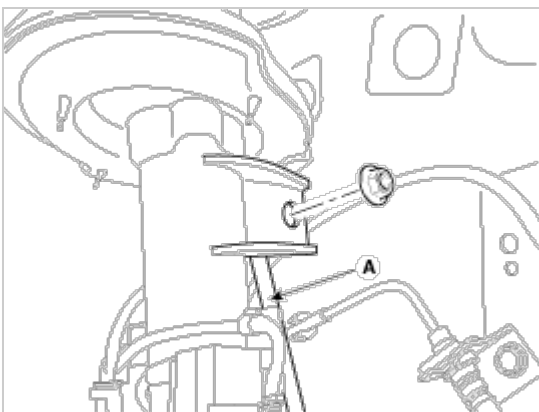

16. Disconnect the tie-rod end (A) from the front knuckle.

---

**Tightening Torque :**

34.3~44.1N.m(3.5~4.5kgf.m, 25.3~32.5lb-ft)

---

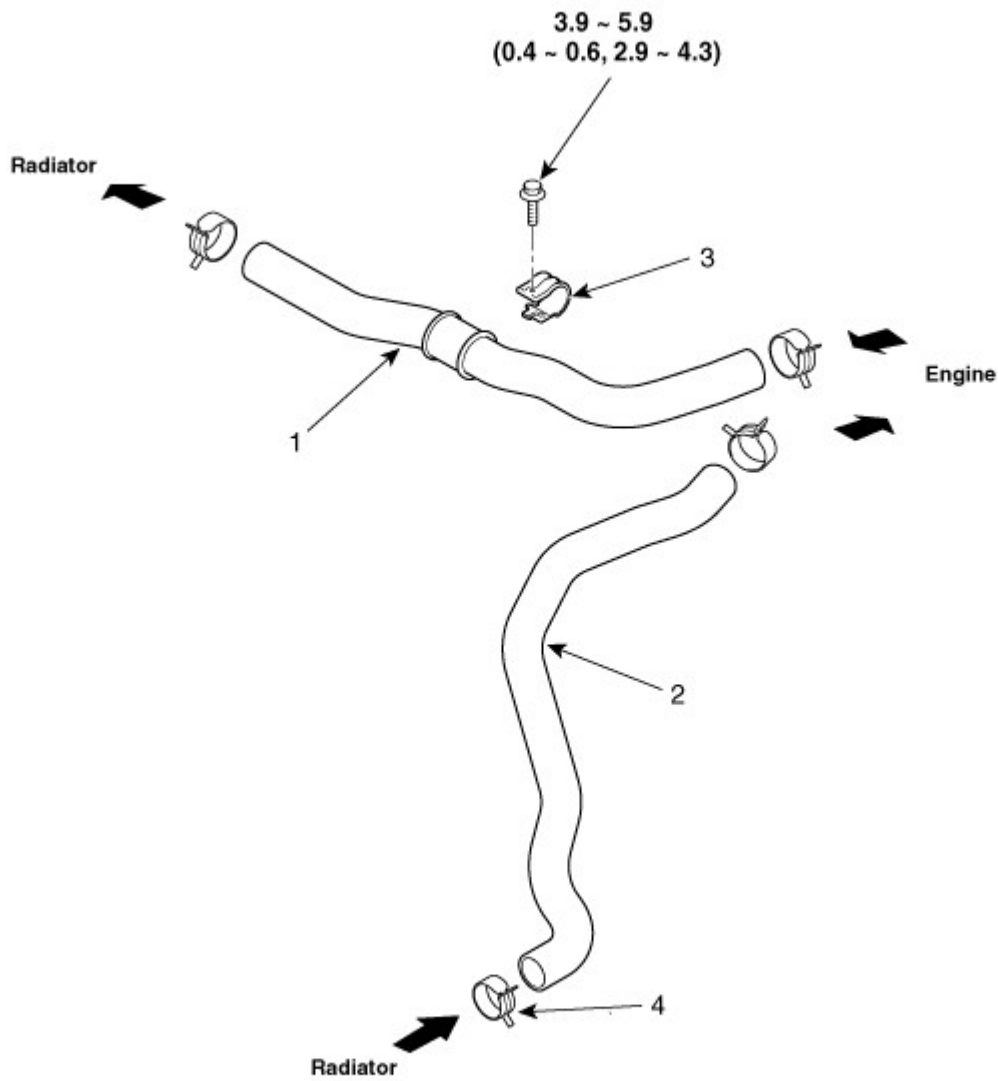

**Torque : N.m (kgf.m, lb-ft)**

- 1. Radiator upper hose
- 2. Radiator lower hose

- 3. Hose clip
- 4. Clamp

## Engine Mechanical System



### Removal and Installation

1. Remove the battery and tray.  
(Refer to Engine Electrical System - "Battery")
2. Remove the air duct and air cleaner assembly.  
(Refer to Intake And Exhaust System - "Air Cleaner")
3. Drain the coolant.  
(Refer to Cooling System - "Coolant")
4. Loosen the upper hose clip fixing bolt (A), and then remove the radiator upper hose (B) and lower hose (C).

#### Tightening torque:

3.9 ~ 5.9 N.m (0.4 ~ 0.6 kgf.m, 2.9 ~ 4.3 lb-ft)

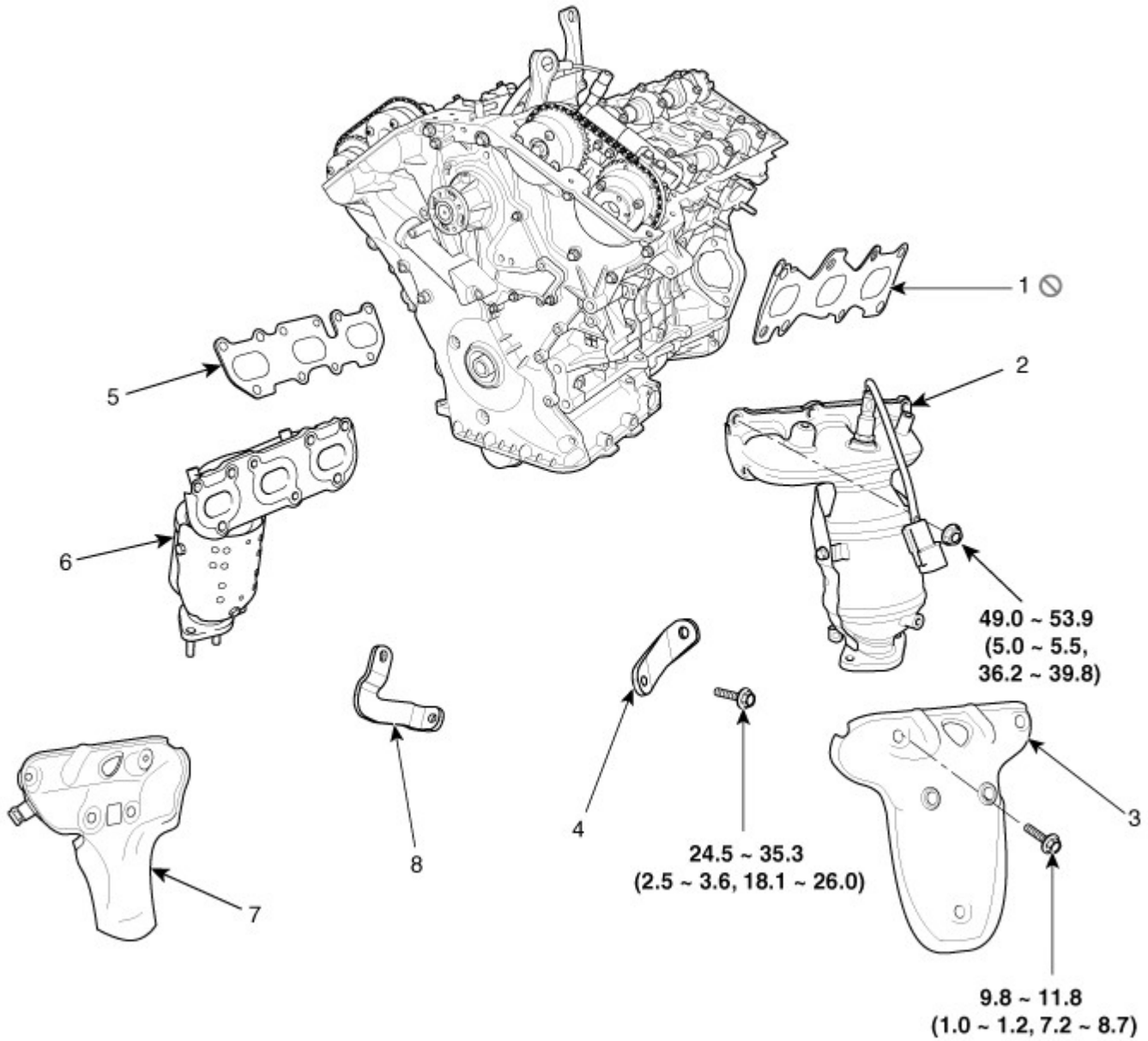

**Torque : N.m (kgf.m, lb-ft)**

- |                               |                               |
|-------------------------------|-------------------------------|
| 1. LH Exhaust manifold gasket | 5. RH Exhaust manifold gasket |
| 2. LH Exhaust manifold        | 6. RH Exhaust manifold        |
| 3. LH Heat protector          | 7. RH Heat protector          |
| 4. LH Exhaust manifold stay   | 8. RH Exhaust manifold stay   |

**Engine Mechanical System**



**Removal and Installation**

**[LH]**

1. Disconnect the LH front and rear heated oxygen sensor (HO2S) connector.  
(Refer to Fuel System - "Heated Oxygen Sensor (HO2S)")
2. Remove the front muffler.  
(Refer to Intake And Exhaust System - "Front Muffler")
3. Remove the cooling fan assembly.  
(Refer to Cooling System - "Cooling Fan")
4. Remove oil level gauge assembly.  
(Refer to Lubrication System - "Oil Level Gauge & Pipe")
5. Remove the LH exhaust manifold heat protector (A).

**Tightening torque :**

9.8 ~ 11.8N.m (1.0 ~ 1.2kgf.m, 7.2 ~ 8.7lb-ft)

To seat new brushes, slip a strip of #500 or #600 sandpaper, with the grit side up, between the commutator and each brush, and smoothly rotate the armature. The contact surface of the brushes will be sanded to the same contour as the commutator.

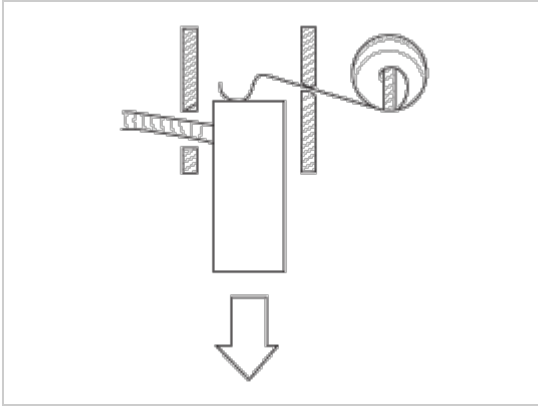

## Inspect Overrunning Clutch

1. Slide the overrunning clutch along the shaft.  
Replace it if it does not slide smoothly.
2. Rotate the overrunning clutch both ways.  
Does it lock in one direction and rotate smoothly in reverse? If it does not lock in either direction or it locks in both directions, replace it.

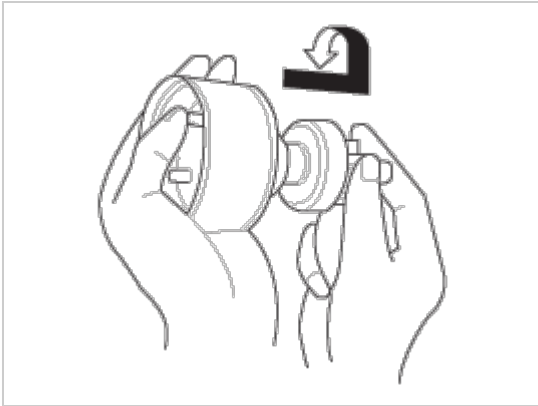

3. If the starter drive gear is worn or damaged, replace the overrunning clutch assembly. (the gear is not available separately).  
Check the condition of the flywheel or torque converter ring gear if the starter drive gear teeth are damaged.

## Cleaning

1. Do not immerse parts in cleaning solvent. Immersing the yoke assembly and/or armature will damage the insulation. Wipe these parts with a cloth only.
2. Do not immerse the drive unit in cleaning solvent. The overrun clutch is pre-lubricated at the factory and solvent will wash lubrication from the clutch.
3. The drive unit may be cleaned with a brush moistened with cleaning solvent and wiped dry with a cloth.

## Engine Electrical System



### Inspection

1. Remove the fuse box cover.
2. Remove the starter relay (A).

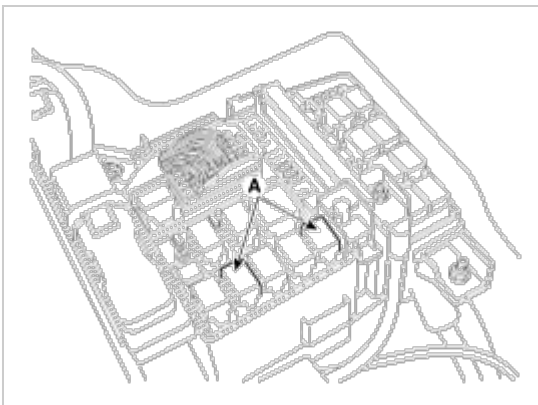

3. Using an ohmmeter, check that there is continuity between each terminal.

### 3. OBD-II system readiness tests

#### 1) Catalyst monitoring

The catalyst efficiency monitor is a self-test strategy within the ECM or PCM that uses the downstream Heated Oxygen Sensor (HO2S) to determine when a catalyst has fallen below the minimum level of effectiveness in its ability to control exhaust emission.

#### 2) Misfire monitoring

Misfire is defined as the lack of proper combustion in the cylinder due to the absence of spark, poor fuel metering, or poor compression. Any combustion that does not occur within the cylinder at the proper time is also a misfire. The misfire detection monitor detects fuel, ignition or mechanically induced misfires. The intent is to protect the catalyst from permanent damage and to alert the customer of an emission failure or an inspection maintenance failure by illuminating the MIL. When a misfire is detected, special software called freeze frame data is enabled. The freeze frame data captures the operational state of the vehicle when a fault is detected from misfire detection monitor strategy.

#### 3) Fuel system monitoring

The fuel system monitor is a self-test strategy within the ECM or PCM that monitors the adaptive fuel table. The fuel control system uses the adaptive fuel table to compensate for normal variability of the fuel system components caused by wear or aging. During normal vehicle operation, if the fuel system appears biased lean or rich, the adaptive value table will shift the fuel delivery calculations to remove bias.

#### 4) Engine cooling system monitoring

The cooling system monitoring is a self-test strategy within the ECM or PCM that monitors ECTS (Engine Coolant Temperature Sensor) and thermostat about circuit continuity, output range, rationality faults.

#### 5) O2 sensor monitoring

OBD-II regulations require monitoring of the upstream Heated O2 Sensor (H2OS) to detect if the deterioration of the sensor has exceeded thresholds. An additional HO2S is located downstream of the Warm-Up Three Way Catalytic Converter (WU-TWC) to determine the efficiency of the catalyst.

Although the downstream H2OS is similar to the type used for fuel control, it functions differently. The downstream HO2S is monitored to determine if a voltage is generated. That voltage is compared to a calibrated acceptable range.

#### 6) Evaporative emission system monitoring

The EVAP. monitoring is a self-test strategy within the ECM or PCM that tests the integrity of the EVAP. system. The complete evaporative system detects a leak or leaks that cumulatively are greater than or equal to a leak caused by a 0.040 inch and 0.020 inch diameter orifice.

#### 7) Air conditioning system monitoring

The A/C system monitoring is a self-test strategy within the ECM or PCM that monitors malfunction of all A/C system components at A/C ON.

#### 8) Comprehensive components monitoring

The comprehensive components monitoring is a self-test strategy within the ECM or PCM that detects fault of any electronic powertrain components or system that provides input to the ECM or PCM and is not exclusively an input to any other OBD-II monitor.

#### 9) A/C system component monitoring

#### Requirement:

If a vehicle incorporates an engine control strategy that alters off idle fuel and/or spark control when the A/C system is on, the OBD II system shall monitor all electronic air conditioning system components for malfunctions that cause the system to fail to invoke the alternate control while the A/C system is on or cause the system to invoke the alternate control while the A/C system is off.

Additionally, the OBD II system shall monitor for malfunction all electronic air conditioning system components that are used as part of the diagnostic strategy for any other monitored system or component.

#### Implementation plan:

No engine control strategy incorporated that alters off idle fuel and/or spark control when A/C system is on. Malfunction of A/C system components is not used as a part of the diagnostic strategy for other monitored system or component.

#### Engine Control/Fuel System



### Components Location

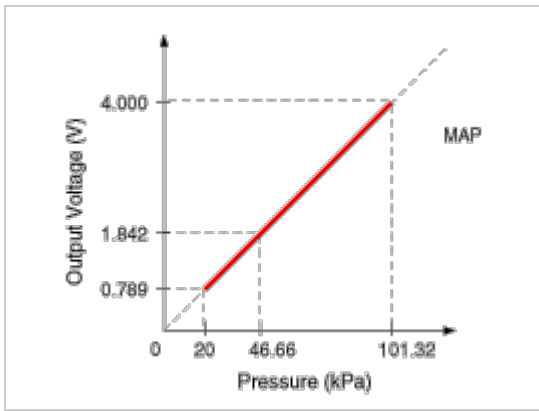

## Circuit Diagram

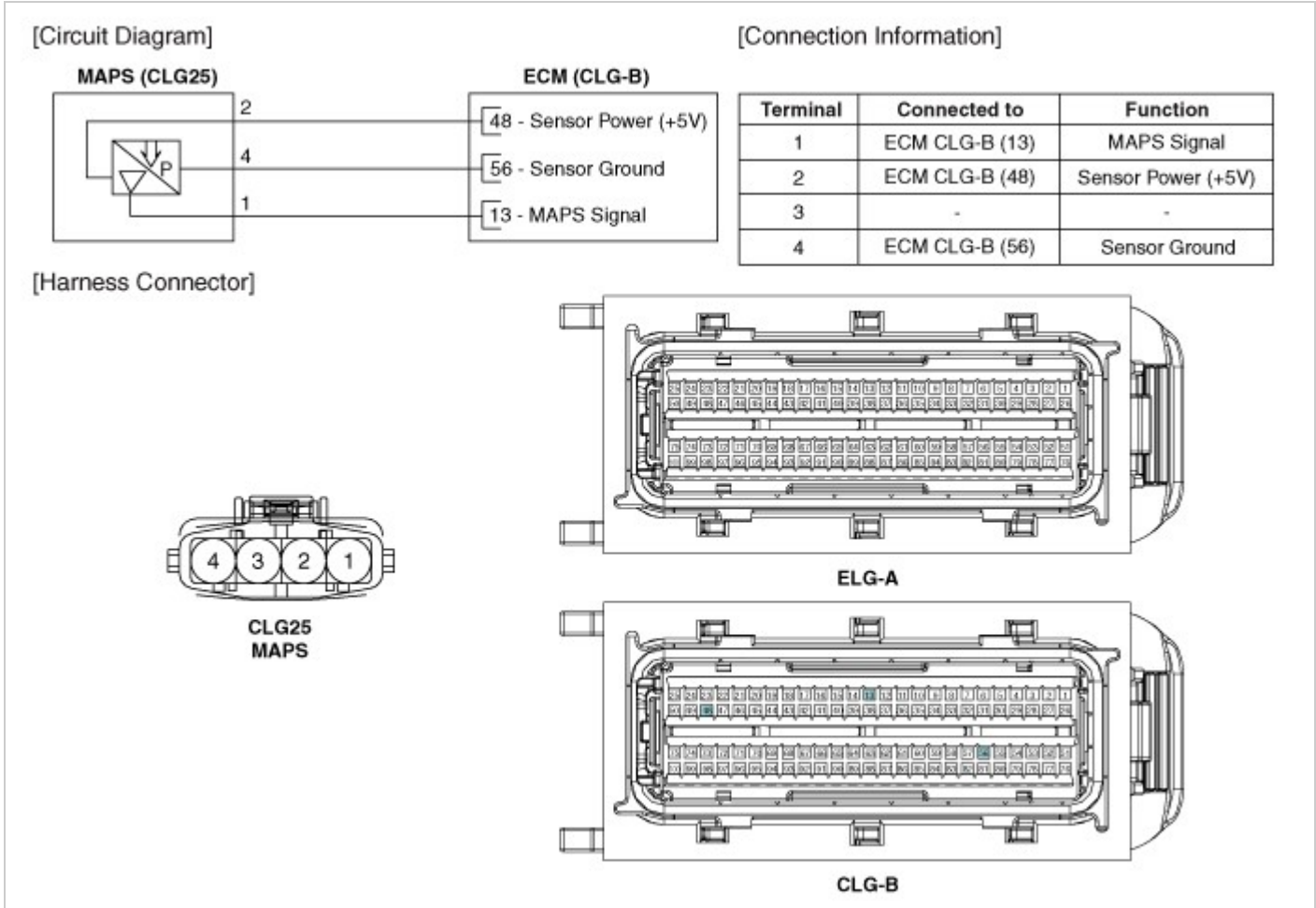

## Inspection

1. Connect the GDS on the Data Link Connector (DLC).
2. Measure the output voltage of the MAPS at idle and IG ON.

Condition	Output Voltage (V)
IG ON	Approx. 4.44V
Idle	Approx. 0.75V

## Removal

1. Turn the ignition switch OFF and disconnect the battery negative (-) cable.
2. Disconnect the manifold absolute pressure sensor connector (A).
3. Remove the installation bolt (B), and then vertically remove the sensor from the surge tank.

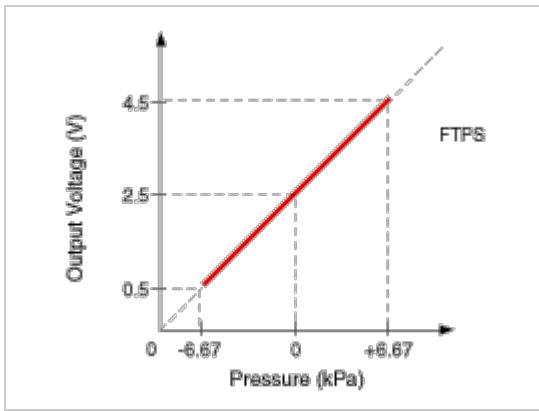

## Circuit Diagram

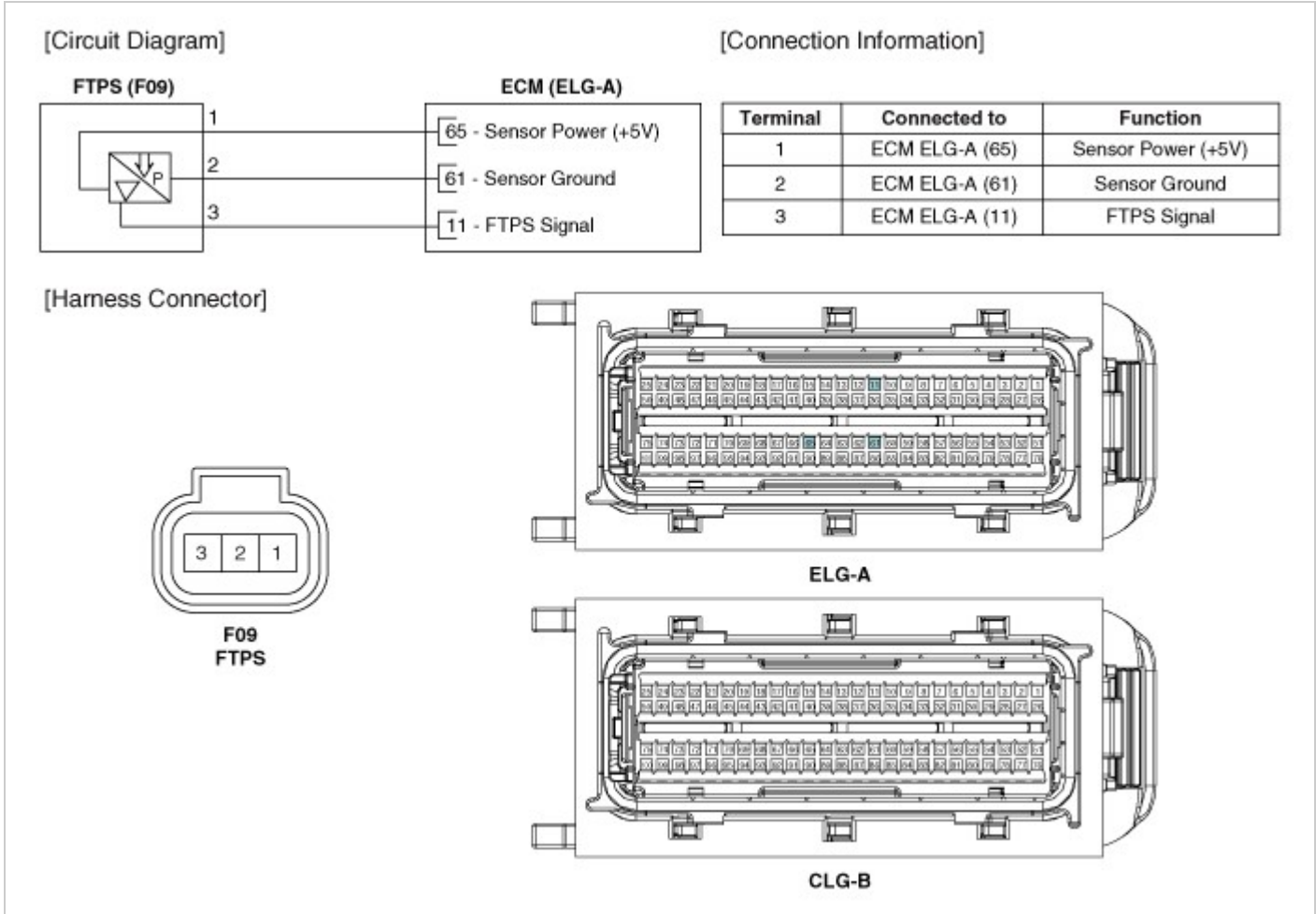

## Inspection

1. Connect the GDS on the Data Link Connector (DLC).
2. Measure the output voltage of the FTPS.

**Specification:** Refer to "Specification"

## Removal

1. Turn the ignition switch OFF and disconnect the battery negative (-) cable.
2. Remove the floor mat in the trunk.
3. Remove the service cover (A).

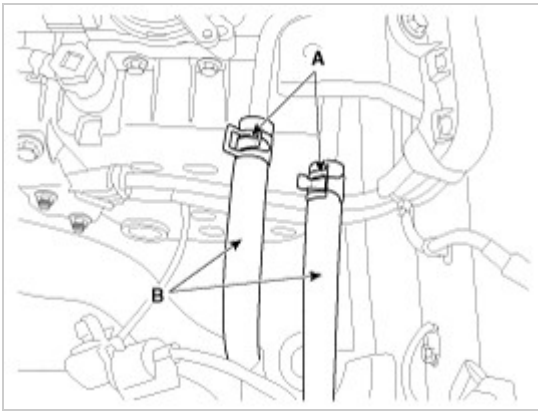

5. Remove the radiator mounting brackets (A).

**Tightening torque:**

3.9 ~ 5.9 N.m (0.4 ~ 0.6 kgf.m, 2.9 ~ 4.3 lb-ft)

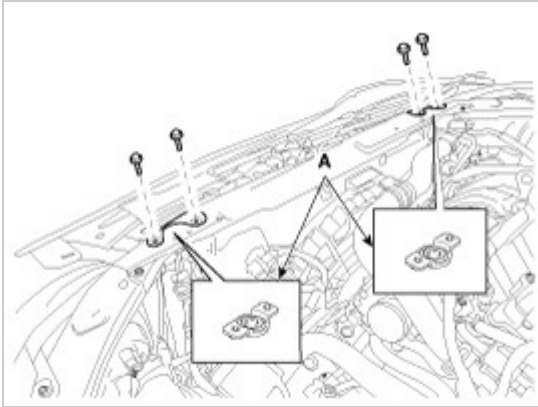

6. Separate the condenser from the radiator and then pull radiator (A) up and remove it from engine room.

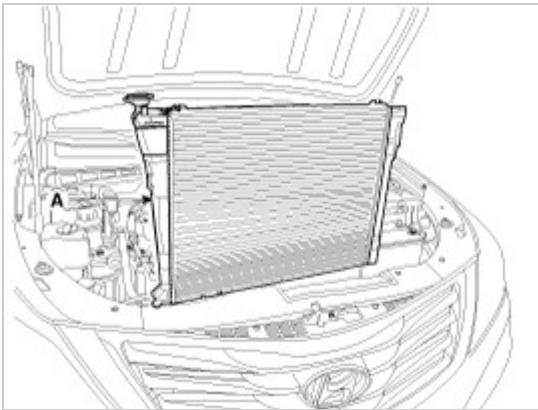

7. Installation is in the reverse order of removal.

8. Fill the radiator with coolant and check for leaks.

**NOTICE**

- Bleed air from the cooling system.
  - Start engine and let it run until it warms up. (Until the radiator fan operates 3 or 4 times.)
  - Turn off engine and let it cool down. Check the coolant level and add coolant if needed. This will allow trapped air to be removed from the cooling system.
  - Put the radiator cap on tightly, then run engine again and check for leaks.

## Inspection

### Radiator Cap Testing

1. Remove the radiator cap, wet its seal with engine coolant, and then install it on a pressure tester.

# Circuit Diagram

## [Circuit Diagram]

### Solenoid Valve [CLG04]

### TCM [CLG-B]

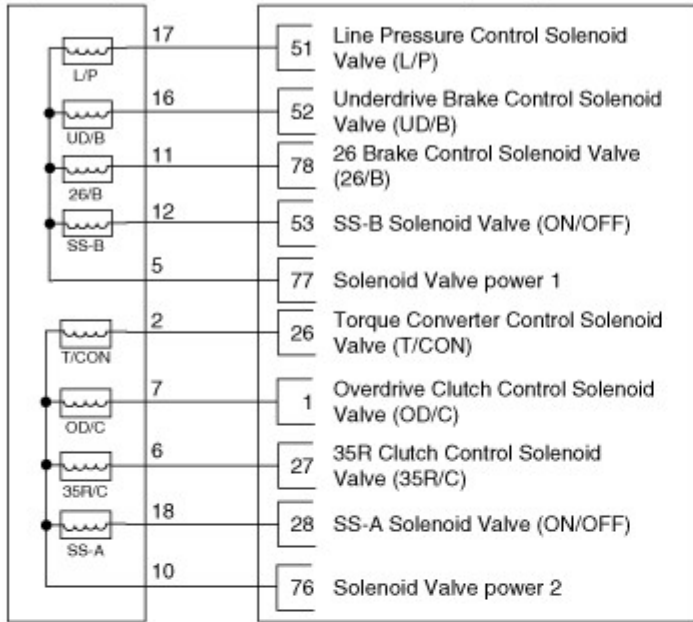

## [Connection Information]

Terminal	Connected to	Function
17	TCM (51)	Line Pressure Control Solenoid Valve (L/P)
16	TCM (52)	Underdrive Brake Control Solenoid Valve (UD/B)
11	TCM (78)	26 Brake Control Solenoid Valve (26/B)
12	TCM (53)	SS-B Solenoid Valve (ON/OFF)
5	TCM (77)	Solenoid Valve power 1
2	TCM (26)	Torque Converter Control Solenoid Valve (T/CON)
7	TCM (1)	Overdrive Clutch Control Solenoid Valve (OD/C)
6	TCM (27)	35R Clutch Control Solenoid Valve (35R/C)
18	TCM (28)	SS-A Solenoid Valve (ON/OFF)
10	TCM (76)	Solenoid Valve power 2

## [Harness Connector]

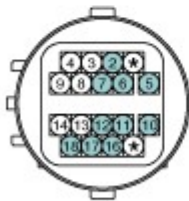

Solenoid Valve Connector [CLG04]

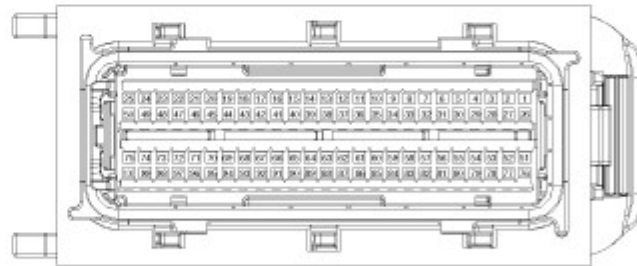

TCM Connector [ELG-A]

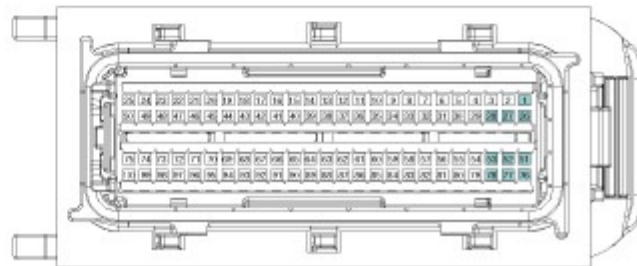

TCM Connector [CLG-B]

## Automatic Transaxle System

### Inspection

1. Turn ignition switch OFF.
2. Remove the air duct.  
(Refer to Engine Mechanical System - "Air cleaner")
3. Disconnect the solenoid valve connector (A).





This function is used to write the VIN into the ECM's memory.

[ Condition ] : IG. On ( Engine Off )

Press [OK] button, after typing the number.

Read : 000000000000000000

Write :

G N E 1 2 3 A V R 1 2 3 4 5 6 7 8

Ok

Cancel



This function is used to write the VIN into the ECM's memory.

[ Condition ] : IG. On ( Engine Off )

Pre

Re

Wr

Writing success !!!  
Press [OK] button.

Ok

G N E 1 2 3 A V R 1 2 3 4 5 6 7 8

Ok

Cancel

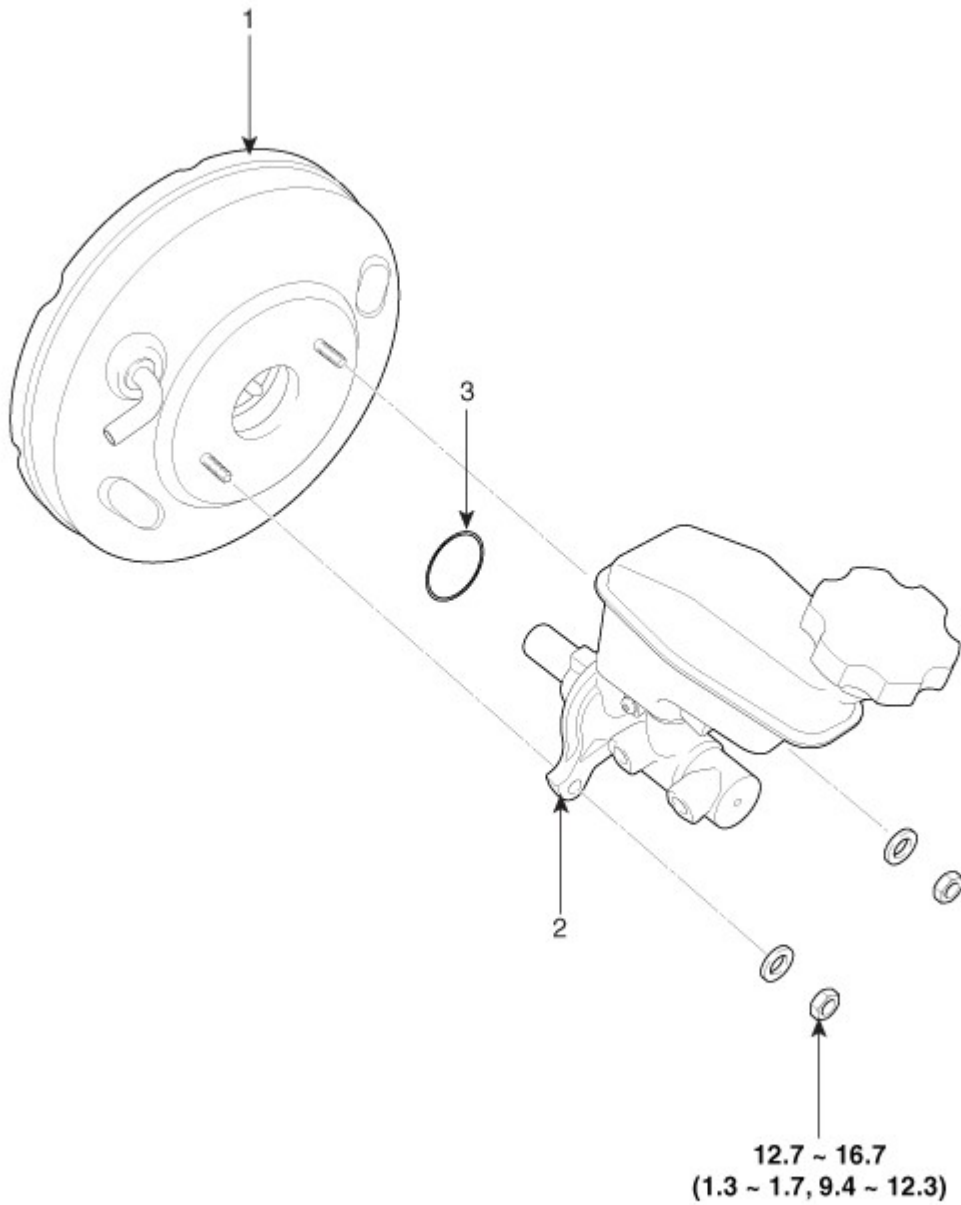

**Torque : N.m (kgf.m, lb-ft)**

- 1. Brake booster
- 2. Master cylinder assembly

3. O-ring

**Brake System**



**Brake Booster Operating Test**

For simple checking of the brake booster operation, carry out the following tests.

1. Run the engine for one or two minutes, and then stop it. If the pedal depresses fully the first time but gradually becomes higher when depressed succeeding times, the booster is operating properly, if the pedal height remains unchanged, the booster is inoperative.

4. Remove the front wheel speed sensor cable mounting bolt.
5. Disconnect the front wheel speed sensor connector, then remove the front wheel speed sensor.
6. Installation is the reverse of removal.

## Brake System



### Components

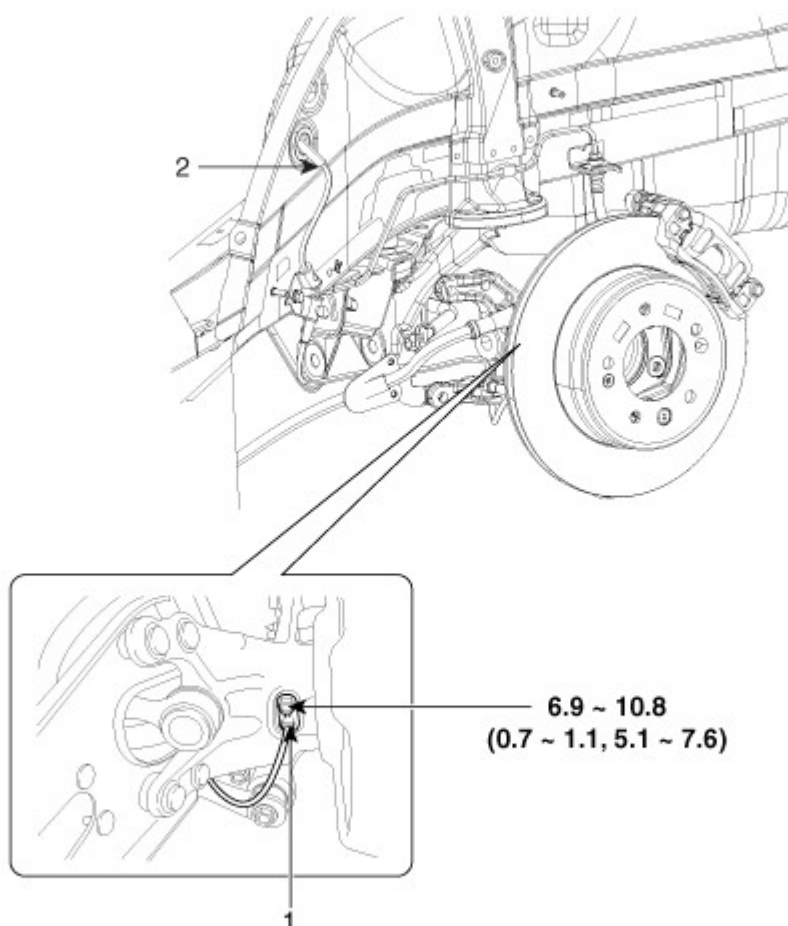

**Torque : N.m (kgf.m, lb-ft)**

1. Rear wheel speed sensor
2. Rear wheel speed sensor cable

## Brake System



### Removal

1. Remove the rear wheel and tire.

**Tightening torque:**

88.3 ~ 107.9 N.m (9.0 ~ 11.0 kgf.m, 65.1 ~ 79.6 lb-ft)

2. Remove the rear wheel speed sensor mounting bolt (A).

**Tightening torque:**

6.9 ~ 10.8 N.m (0.7 ~ 1.1 kgf.m, 5.1 ~ 7.6 lb-ft)

## Replacement

1. Open the movable glass fully.
2. Remove the folding cover (A).

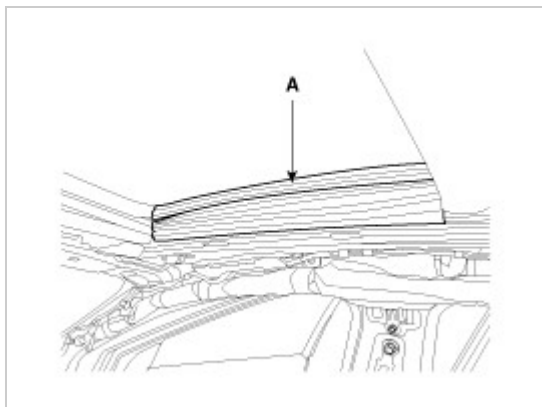

3. After loosening the mounting screws, then remove the movable glass (A).

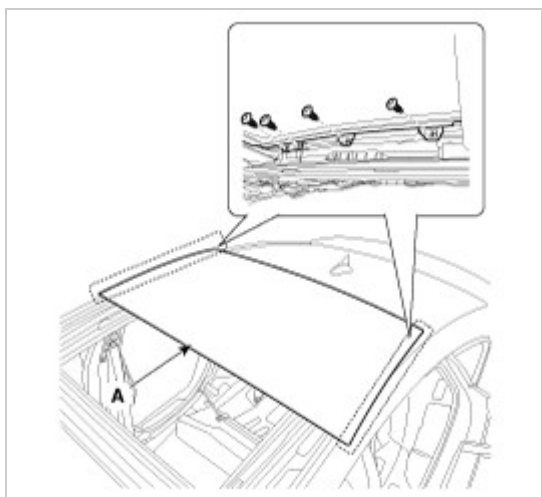

### **CAUTION**

- Do not damage the screws.

4. Installation is the reverse of removal.

## Body (Interior and Exterior)



## Replacement

1. Open the panoramaroof deflector fully.
2. Remove the panoramaroof deflector mounting bracket (A) as arrow.



3. After loosening the mounting screws, then remove the panoramaroof deflector (A).