

Jacking



[Printable View \(10 KB\)](#)

Jacking Points



WARNING: If equipped, the electrical power to the air suspension system must be shut down prior to hoisting, jacking or towing an air suspension vehicle. This can be accomplished by turning off the air suspension switch located below the glove box in the lower right of the front passenger footwell. Failure to do so may result in unexpected inflation or deflation of the air springs which may result in shifting of the vehicle during these operations.



WARNING: Do not run the engine when jacking the vehicle. The wheels contacting the ground could cause the vehicle to move.



WARNING: Make sure the jack is correctly positioned to prevent the vehicle from falling.



WARNING: Wheel chocks should be used to prevent the vehicle from rolling and falling off the jack.

Refer to the Owner Guide for additional information on vehicle jacking.

Track Bar — F-450, F-550



[Printable View \(68 KB\)](#)

Removal and Installation

1.  **CAUTION:** Suspension fasteners are critical parts because they affect performance of vital components and systems and their failure can result in major service expense. They must be replaced with the same part number or an equivalent part if replacement is necessary. Do not use a replacement part of lesser quality or substitute design. Torque values must be used as specified during reassembly to ensure proper retention of these parts.

Raise and support the vehicle. For additional information, refer to [Section 100-02](#).

2. **NOTE:** To prevent the front suspension from shifting when the trackbar is removed, the front suspension must be supporting the vehicle weight.

Load the front suspension with the vehicle weight.

1. Position the jack stand under the front axle assembly.
2. Lower the vehicle until the front suspension is supporting the vehicle weight.

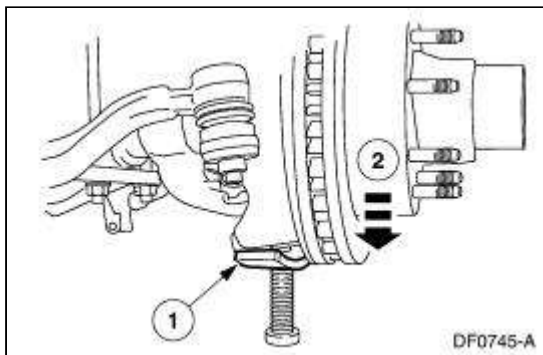

3. Remove the nut and bolt and disconnect the trackbar from the upper mounting bracket.

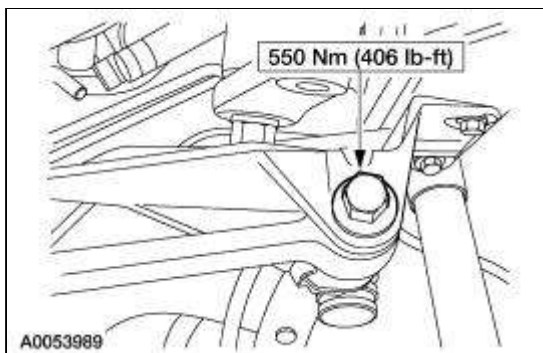

4. Remove the nut, bolt and the trackbar.

Steering Gear Meshload Adjustment — XR50 Steering Gear



Special Tool(s)

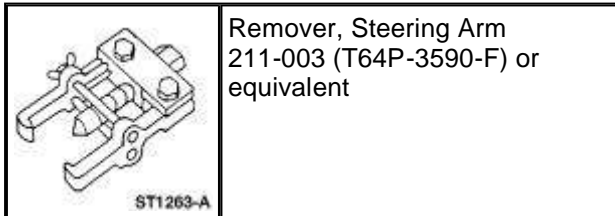

1. **NOTE:** The engine should not be running.

Turn the steering wheel from right lock to left lock at least once.

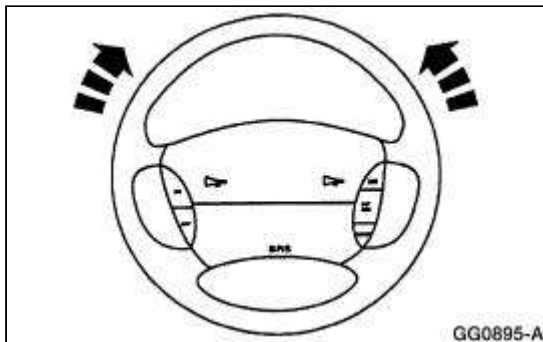

2. Remove the driver air bag. For additional information, refer to [Section 501-20B](#).
3. Raise and support the vehicle. For additional information, refer to [Section 100-02](#).
4. Remove the castellated nut.
 1. Remove the cotter pin.
 2. Remove the castellated nut.

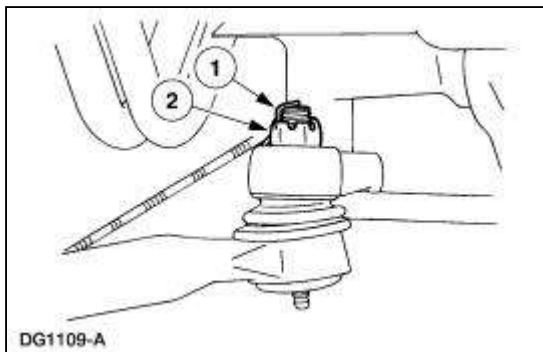

5. Separate the steering sector shaft arm drag link.
 - Use the Pitman Arm Puller to separate the steering sector shaft arm drag link.

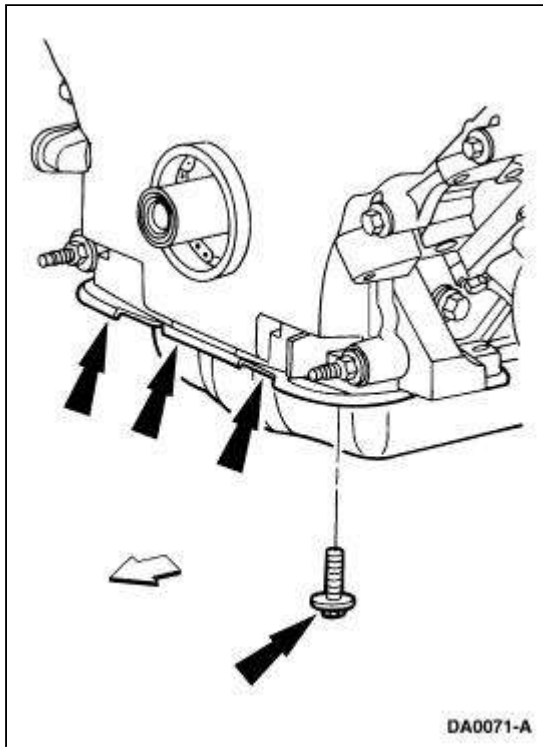

10. Lower the vehicle.
11. Remove the crankshaft front seal. For additional information, refer to [Crankshaft Front Seal](#) in this section.
12. Disconnect the camshaft position (CMP) sensor electrical connection.

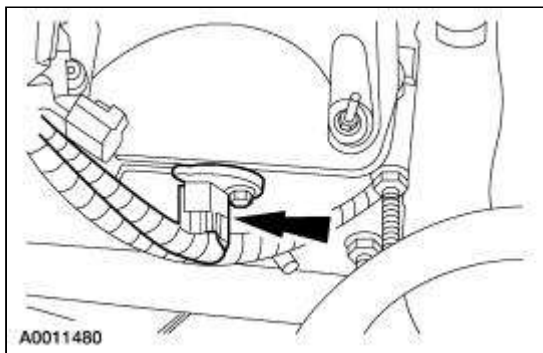

13. Remove the nuts and position the radio interference capacitors aside.

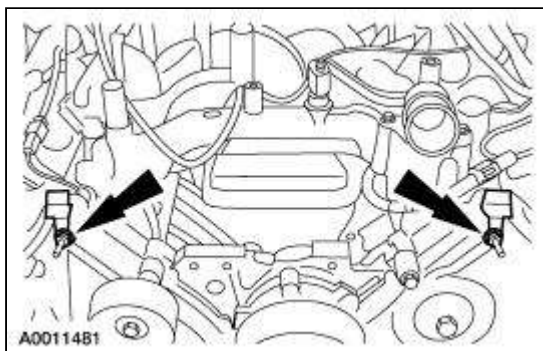

14. Remove the bolt and the belt idler pulley.

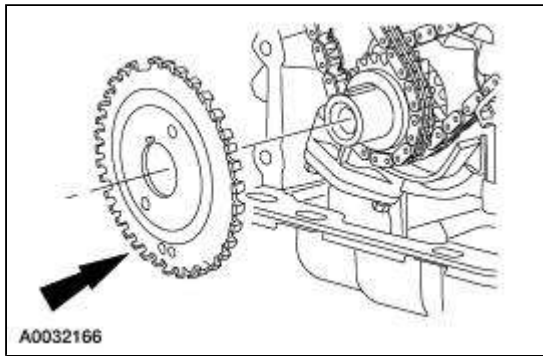

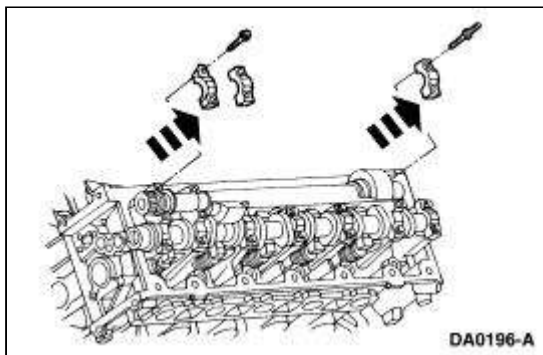

28.  **CAUTION:** The caps must be marked for installation in their original locations or damage to the engine may occur.

Remove the six bolts and remove the balance shaft bearing caps.

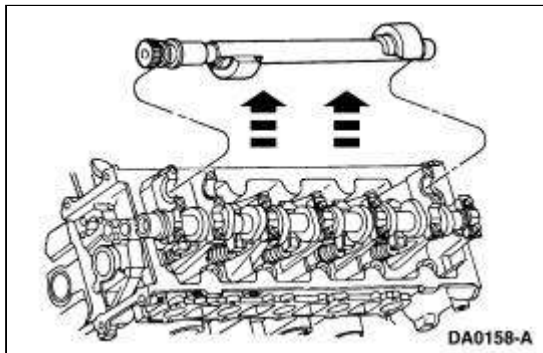

29. Remove the balance shaft.



30.  **CAUTION:** Use care when removing the spark plugs.

NOTE: Use compressed air to remove any foreign material from the spark plug well before removing the spark plugs.

Remove the 10 spark plugs.

31. Install the special tool between the valve spring coils to prevent valve stem seal damage.

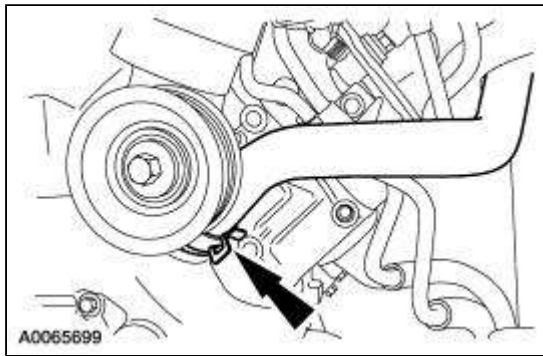

92. Remove the clips and disconnect the fuel lines. For additional information, refer to [Section 310-00](#).

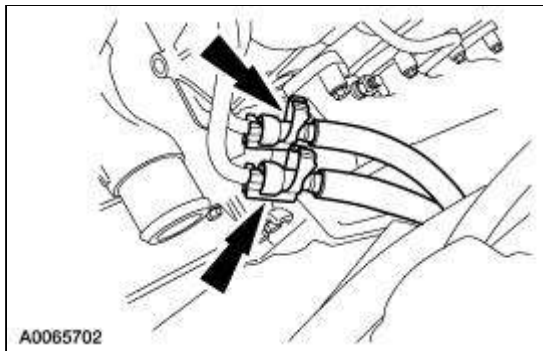

93. Remove the power steering upper mounting bolts.

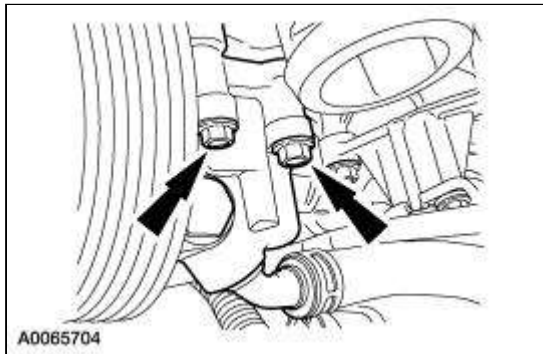

94. **NOTE:** Bolts need to be removed evenly.

Remove the lower bolts and position the power steering pump out of the way and remove LH standoff for the stator.

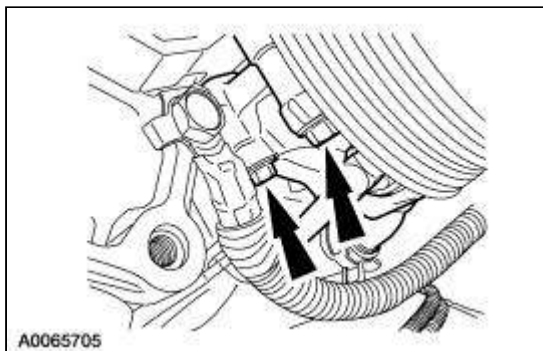

95. Remove the nut and the battery cable bracket, and remove the RH standoff for the stator.

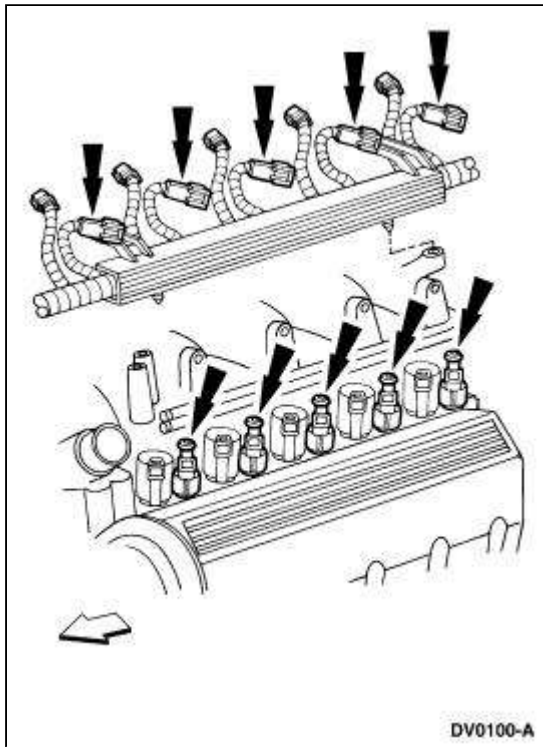

9. Remove the crankcase vent connector and hose.

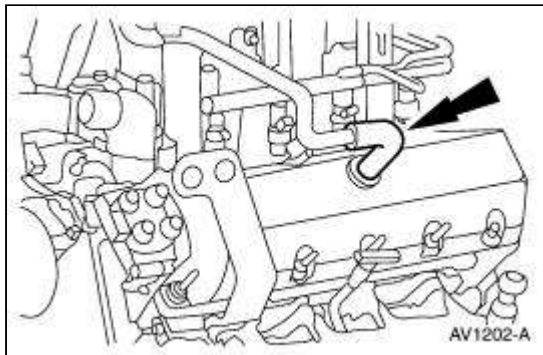

10. Remove the four bolts, the fuel injection supply manifold assembly and fuel injectors.
 - Discard the fuel injector O-ring seals.

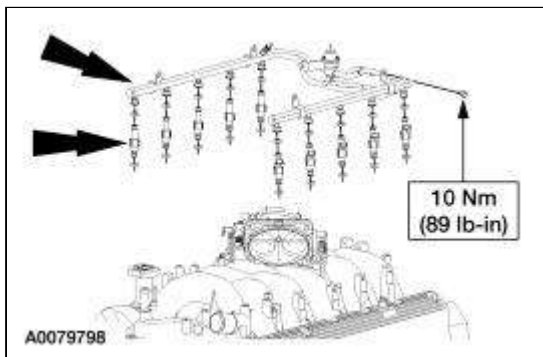

11.  **CAUTION: Check for fuel leakage after installation is complete.**

NOTE: Be sure fuel injectors and fuel injection supply manifold are fully seated.



[Printable View \(10 KB\)](#)

General Specifications

Item	Specification
SAE 15W-40 Super Duty Motor Oil XO-15W40-QSD or equivalent	WSS-M2C171-B

Torque Specifications

Description	Nm	lb-ft	lb-in
Engine coolant temperature (ECT) sensor	12	9	—
Fuel injector control module (FICM) mounting bolts and stud bolts	13	10	—
Powertrain control module (PCM) mounting bolts	7	—	62
Crankshaft position (CKP) sensor	11	8	—
Camshaft position (CMP) sensor	11	8	—
Intake air temperature (IAT) sensor	17	13	—
Exhaust back pressure (EBP) sensor	10	—	89
Engine oil temperature (EOT) sensor	12	9	—
Engine oil pressure (EOP) sensor	12	9	—
Turbocharger variable geometry control valve	24	18	—

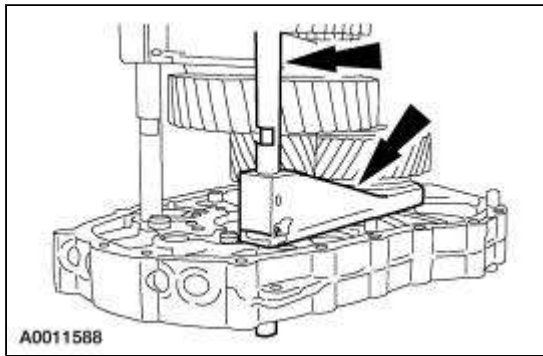

29. Using a 5 mm (3/16 in) punch, align the roll pin hole with the top hole of the shift fork. Install the double roll pin in the lower hole, then install a roll pin in the upper hole.
- Do not hit the sealing surface of the intermediate plate.
 - Make sure the slot of the roll pin is facing away from the shift rail.

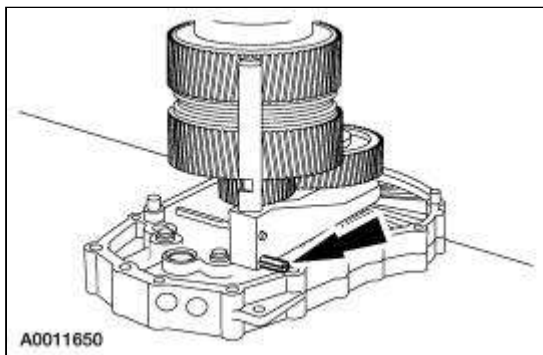

30. **NOTE:** Using an oil stone or emery cloth, lightly condition the shift rails and clean them with transmission fluid before installing the shift forks and rails.

NOTE: Move the interlock plate into the low/reverse position.

Install the low/reverse gear shift fork and the shift rail.

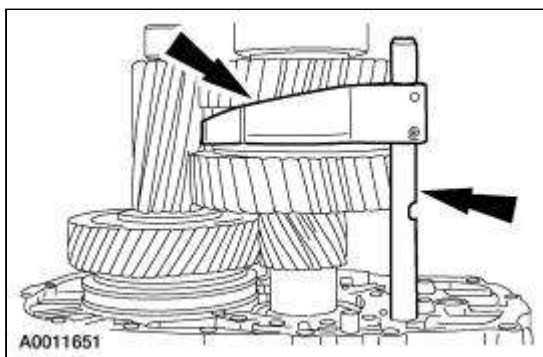

31. Using a 5 mm (3/16 in) punch, align the roll pin hole with the top hole of the shift fork. Install the double roll pin in the lower hole, then install a roll pin in the upper hole.
- Make sure the slot of the roll pin is facing away from the shift rail.

1, I circuit 1185 (YE), harness side and the PCM C1381c pin 4, circuit 1185 (YE), harness side; and between the lower generator C1251a pin 1, I circuit 1185 (YE) harness side and ground.

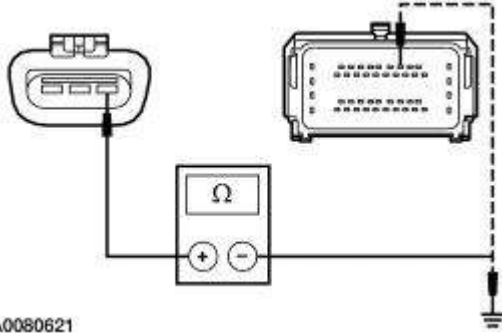

A0080621

- Is the resistance less than 5 ohms between the generator and the PCM and greater than 10,000 ohms between the generator and ground?

1185 (YE). CLEAR the DTCs. TEST the system for normal operation.

U6 CHECK LOWER GENERATOR VOLTAGE

- Connect: PCM C1381c.
- Disconnect: Upper Generator C102a.
- Connect: Lower Generator C1251a.
- Key in START position.
- **NOTE:** After starting the engine, wait at least two minutes for the glow plugs to stop cycling.
- With the engine running, measure the voltage at the battery.

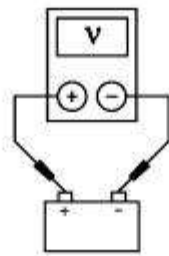

AJ0210-A

- Is the voltage greater than 13 volts?

Yes
GO to [U7](#).

No
INSTALL a new lower generator. REFER to [Section 414-02](#). CLEAR the DTCs. TEST the system for normal operation.

U7 CHECK THE LOWER GENERATOR OUTPUT

- With the upper generator connector still disconnected, check the lower generator output. Refer to Component Tests, Generator On-Vehicle Test — Load Test in this section.
- Is the lower generator OK?

Yes
System is operating normally. RECONNECT all connectors, CLEAR the DTCs. TEST the system for normal operation.

No
INSTALL a new lower generator. REFER to [Section 414-02](#). CLEAR the DTCs. TEST the system for normal operation.

U8 CHECK FOR CORRECT PCM OPERATION

- Disconnect all PCM connectors.
- Check for:
 - corrosion
 - pushed-out pins
- Connect all PCM connectors and make sure they seat correctly.

Yes
INSTALL a new PCM. REFER to [Section 303-14B](#). CLEAR the DTCs. REPEAT the self-test.

- Carefully open the door and tighten the bolts.

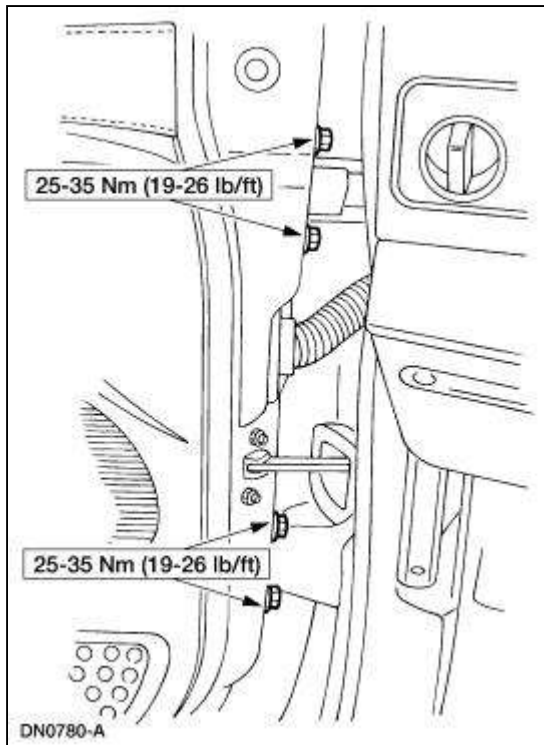

- Re-install and adjust the door striker. For additional information, refer to [Striker Adjustment](#) in this section.
- Check the door for correct operation and alignment.

Door Pre-Adjustment Inspection

NOTE: Before attempting any door adjustment procedures, open and close the door several times and observe the operation. With the door in an open position, attempt to lift the door at the outboard lower edge. Check for excessive up and down travel. If the door exhibits excessive up and down movement, new door hinge bushings or door hinge pins may need to be installed.

NOTE: Door hinges must be in the correct operating condition before the door(s) can be correctly adjusted.

NOTE: Check the door(s) for any of the following conditions.

- Check for the door dropping while opening.
 - If the hinge pin bushings are worn, install new bushings.
 - If the hinge pins are worn, install new hinge pins.
 - If the hinge(s) is damaged, install a new hinge(s).
 - If dirt or corrosion is on the door hinge(s), lubricate the door hinges. Refer to Specifications in this section.
 - Verify if the door closing requires high effort.
-

7. **NOTE:** If reinstalling the removed windshield glass, complete this step and go to step 10. If installing a new windshield glass, skip step 7 and go to step 8.

If reinstalling the same windshield glass, remove the remaining urethane adhesive from the glass leaving a thin layer to bond with the new urethane bead.

8. Clean the inside of the new windshield glass with an alcohol-free glass cleaner.
- Make sure to thoroughly clean the surface of the blackened border area where the urethane adhesive will be applied.

9.  **CAUTION: Wipe off the red urethane glass primer immediately after application before it flash dries.**

 **CAUTION: Make sure the area of red glass primer application aligns with the existing urethane bead on the pinchweld.**

 **CAUTION: For correct installation, two coats of the red glass primer are necessary.**

NOTE: Use a clean wool applicator for each application of the red glass primer.

Making the application approximately 25 mm (1 in) wide, apply two coats of Essex 401 Urethane Glass Primer, Ford specification WSB-M5B280-C2 (red), to the entire inside perimeter of the windshield glass.

- Wipe off immediately after each application.

10.  **CAUTION: The black urethane glass primer must be thoroughly mixed for even pigmentation.**

 **CAUTION: The black glass primer must cure for a minimum of five minutes before the windshield glass is installed.**

NOTE: The black glass primer application must be over the same area as the red primer application.

Using a clean wool applicator, apply Essex 402 Urethane Glass Primer, Ford specification WSB-M2G314-B (black).

11.  **CAUTION: The urethane bead must have a triangular cross section.**

Cut the applicator tip of Essex 400 HV Urethane High Viscosity Adhesive, Ford specification WSB-M2G316-B, to specification. This will produce a triangular bead during application.

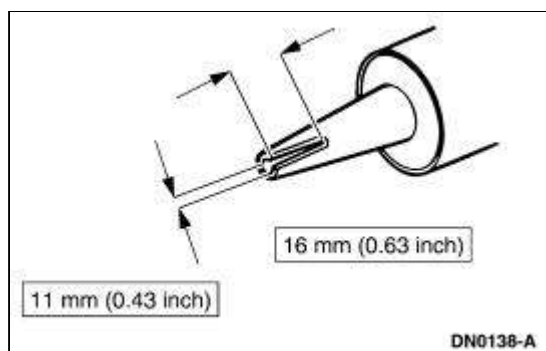

The air bag restraint system diagnostic tools must be removed and the air bag modules reconnected when the system is reactivated to avoid non-deployment in a collision, resulting in possible personal injury. **NOTE:** Diagnostics or repairs are not to be performed on a seat equipped with a seat side air bag with the seat in the vehicle. Prior to attempting to diagnose or repair a seat concern when equipped with a seat side air bag, the seat must be removed from the vehicle and the restraint system diagnostic tools must be installed in the seat side air bag electrical connectors. **The restraint system diagnostic tools must be removed prior to operating the vehicle over the road. NOTE:** After diagnosing or repairing an SRS, the restraint system diagnostic tools must be removed before operating the vehicle over the road. **NOTE:** After diagnosing or repairing a seat system, the restraint system diagnostic tools must be removed before operating the vehicle over the road. **NOTE:** The SRS must be fully operational and free of faults before releasing the vehicle to the customer.

- Key in OFF position.
- Deactivate the system. Refer to [Air Bag and Safety Belt Pretensioner Supplemental Restraint System \(SRS\)](#) in the Diagnosis and Testing portion of this section.
- Key in ON position.
- Enter the following diagnostic mode on the diagnostic tool: On-Demand Self Test.
- **Was DTC B1888 retrieved?**

M3 CHECK THE PASSENGER AIR BAG MODULE CIRCUIT

- Key in OFF position.
- Disconnect: RCM C2041.
- **NOTE:** Do not separate or remove shorting bars from RCM C2041.
- Measure the resistance between RCM C2041 pin 6, circuit 607 (LB/OG), harness side and RCM C2041 pin 21, circuit 649 (BK/OG), harness side.

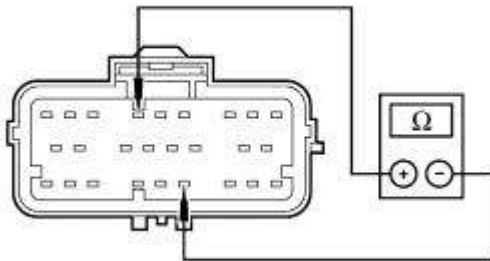

- **Is the resistance greater than 10,000 ohms?**

Yes
INSTALL and CONFIGURE a new RCM. GO to [M6](#).

No
GO to [M4](#).

M4 CHECK THE PASSENGER AIR BAG MODULE WIRING

- Disconnect: Passenger Air Bag Module Restraint System Diagnostic Tool.
- Inspect all crimps, terminals, wires and connectors in circuit 607 (LB/OG) feeding the RCM pin 6, circuit 616 (PK/BK) feeding pin 7. Check for pinched wires and damaged connector pin terminals.
- **Was any damage found?**

Yes
REPAIR as necessary. GO to [M6](#).

No
GO to [M6](#).

M5 CHECK FOR AN INTERMITTENT FAULT

⚠ WARNING: If the supplemental restraint system (SRS) is being serviced, the system must be deactivated and restraint system diagnostic tools must be installed. Refer to [Air Bag and Safety Belt Pretensioner Supplemental Restraint System \(SRS\)](#) in this section.

Yes
CHECK for causes of intermittent fault at or near the passenger air bag module connector.

2004 Ford Pickup F250 Super Duty

2004 SYSTEM WIRING DIAGRAMS Ford - Pickup F250 Super Duty

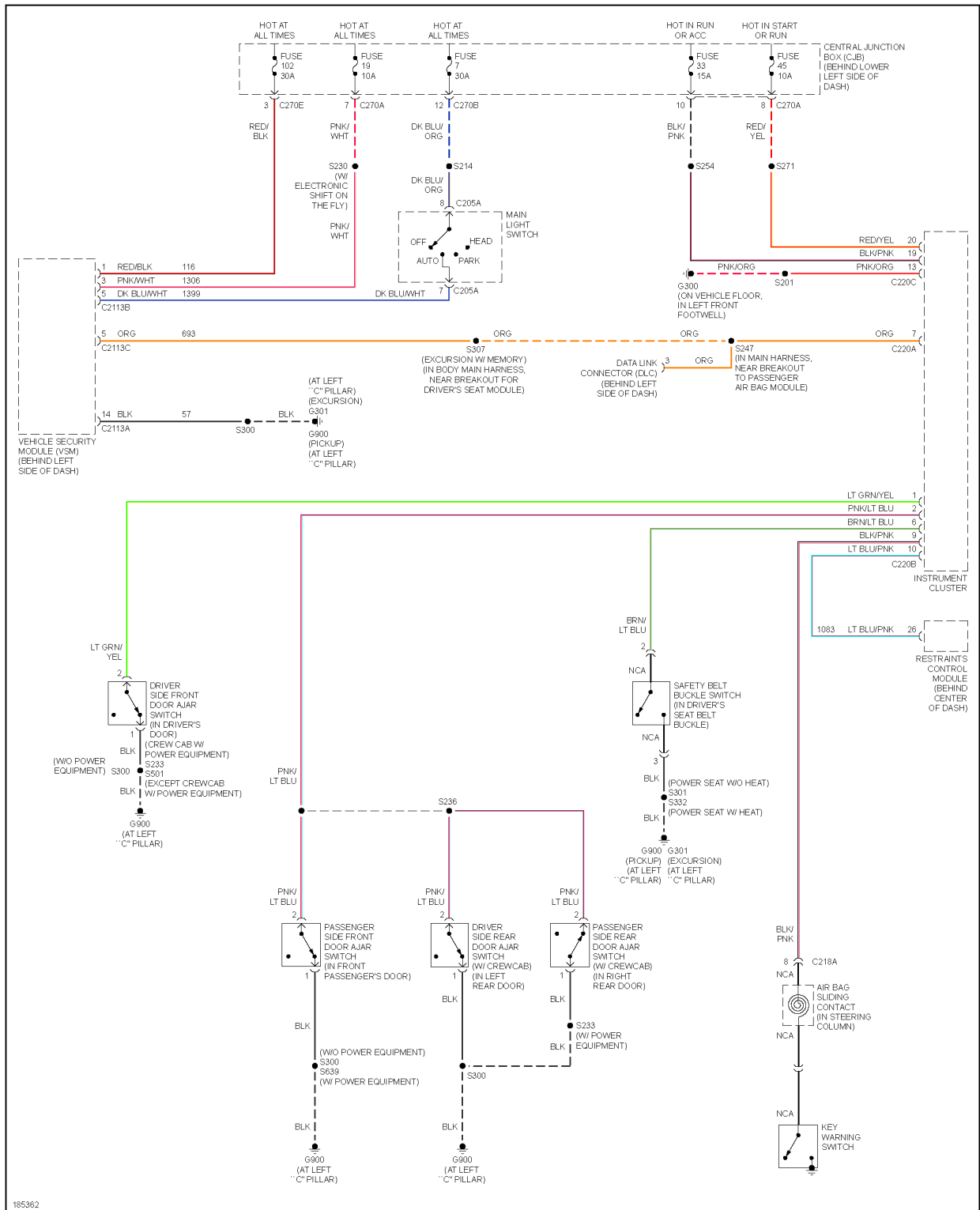
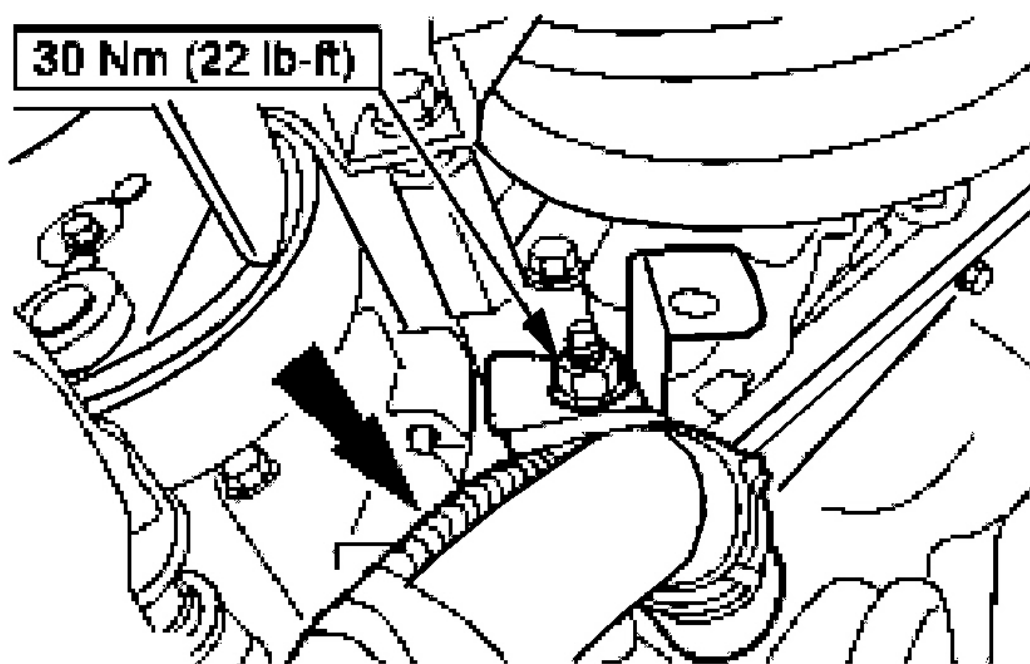

Fig. 77: Warning Systems Circuit, W/O Remote/Keyless Entry

WIPER/WASHER



G0277728

Fig. 33: Removing Nut And Position Battery Positive Cable And Bracket
Courtesy of FORD MOTOR CO.

9. Release the battery positive cable locators from the engine and frame.
10. Remove the nut and position the generator B+ cable aside.