



## Contents

<b>00 - Technical data</b>	<b>1</b>
<b>1 Gearbox identification</b>	<b>1</b>
<b>2 Code, engine allocation</b>	<b>2</b>
<b>3 Capacities</b>	<b>3</b>
<b>4 General repair notes</b>	<b>4</b>
4.1 Tools	4
4.2 Gearbox	4
4.3 Oil	6
4.4 Working with vehicle diagnostic testers	6
<b>30 - Clutch</b>	<b>8</b>
<b>1 Removing and installing the dual clutch</b>	<b>8</b>
1.1 Removing dual clutch	8
1.2 Adjusting position of engagement bearings "K 1 and K 2"	12
1.3 Installing dual clutch	22
<b>34 - Controls, housing</b>	<b>30</b>
<b>1 Renewing gear oil</b>	<b>30</b>
<b>2 Selector mechanism</b>	<b>33</b>
2.1 Overview - selector mechanism in vehicles up to 02.2009	33
2.2 Removing and installing selector lever cable - vehicles up to 02.2009	34
2.3 Overview of selector mechanism - vehicles from 03.2009 onwards	41
2.4 Removing and installing selector mechanism with selector lever and selector lever cable - vehicles from 03.2009 onwards	42
2.5 Checking selector lever cable	43
2.6 Adjusting selector lever cable	43
2.7 Emergency release of selector lever	46
2.8 Removing and installing selector lever handle	46
2.9 Checking selector mechanism	48
<b>3 Mechatronic unit for dual clutch gearbox J743</b>	<b>50</b>
3.1 Safety note on mechatronic unit for dual clutch gearbox J743	50
3.2 Overview - mechatronic unit	51
3.3 Removing mechatronic unit for dual clutch gearbox J743 with gearbox installed	52
3.4 Moving mechatronic unit for dual clutch gearbox J743 into "removal position" by hand	62
3.5 Installing mechatronic unit for dual clutch gearbox J743	65
3.6 View of selector forks with mechatronic unit removed	72
<b>4 Removing and installing gearbox</b>	<b>73</b>
4.1 Information about gearboxes with different output shafts	73
4.2 Removing gearbox, vehicles with 1.4 l/90 kW TFSI engine and 1.4 l/118 kW TSI engine	74
4.3 Removing gearbox, vehicles with 1.6 l/75 kW MPI engine	81
4.4 Removing gearbox - vehicles with 1.9 l/77 kW TDI PD engine	90
4.5 Removing gearbox - vehicles with 1.6 l/77 kW TDI CR engine	97
4.6 Installing gearbox	104
4.7 Torque settings "Gearbox to engine" and notes on assembly mounting	107
<b>5 Transporting gearbox and securing to assembly stand</b>	<b>111</b>
<b>35 - Gears, shafts</b>	<b>113</b>
<b>1 Currently, no repairs can be made to gears and shafts</b>	<b>113</b>
<b>39 - Final drive - front differential</b>	<b>114</b>
<b>1 Oil seals</b>	<b>114</b>



1.1	Renewing oil seal for right stub shaft .....	114
1.2	Renewing oil seal for left stub shaft .....	116
1.3	Renewing seal for right flange shaft .....	118
1.4	Renewing oil seal for left flange shaft .....	120





## 00 – Technical data

### 1 Gearbox identification

KHN - Gearbox code letters

⇒ [page 2](#)

01.06.06 - Production date:  
1 June 2006

14 - Factory code

14 15 - Time

0026 - Serial number

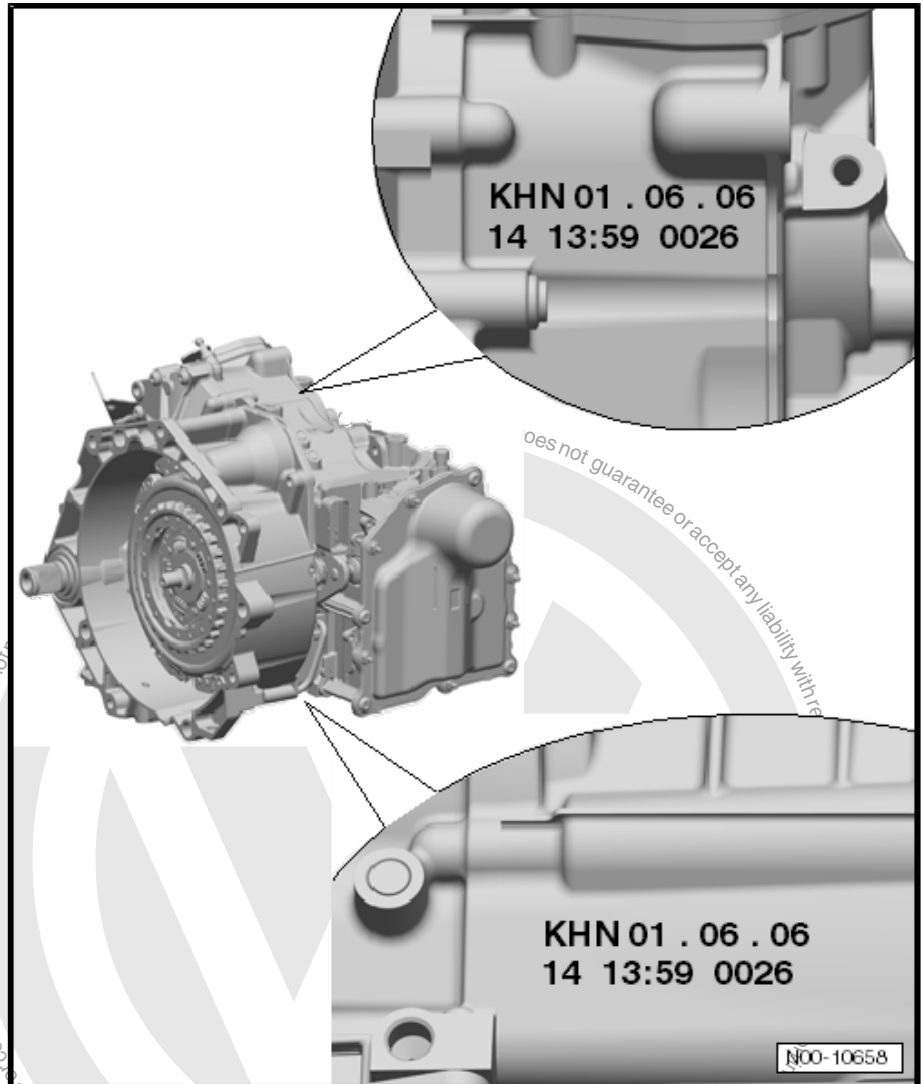



In some vehicles, a cover is fitted over the engaging levers.

The cover prevents dirt getting in.

**Torque setting: 8 Nm**

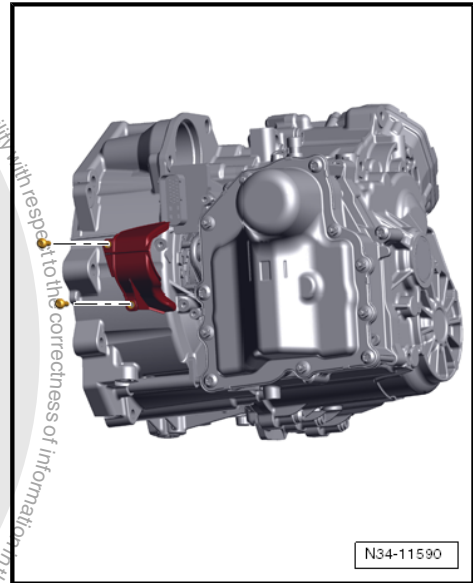

### 4.3 Oil

The "0AM" gearbox has two oil circuits. One oil fill is for gears, shafts and differential. A 2nd oil fill is for mechatronic unit for dual clutch gearbox -J743-

Both oils are Genuine parts [page 3](#).

Do not mix "additives" in oil.

Oil which has been drained out cannot be added again.



#### Caution

*Use caution when handling oil. Dispose of used oil properly. One drop of oil will contaminate 600 litres of water.*

### 4.4 Working with vehicle diagnostic testers

- Only work with vehicle diagnostic testers from Volkswagen.
- ◆ Vehicle diagnosis and service information system -VAS 5052 A-
- ◆ Vehicle diagnosis, testing and information system -VAS 5051B-
- ◆ Vehicle diagnostic tester -VAS 5053-

Various functions are available in the operating modes guided functions and guided fault finding. The 3 most important functions are:

- ◆ Adapting installation information
- ◆ Reading measured values for mandatory reporting
- ◆ Initiating basic adjustment

#### 4.4.1 Adapting installation information

The mechatronic unit detects other control units in the vehicle by means of signals on the data bus. Pressing the Adapt installation information lock button instructs the mechatronic unit to forget all communication partners.



- By "turning", check whether small engagement bearing is installed correctly and that grooves are seated correctly.

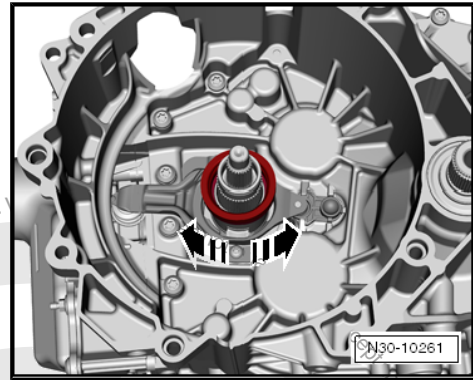

- Place gauge block -T10374- on small bearing "with large opening upwards".

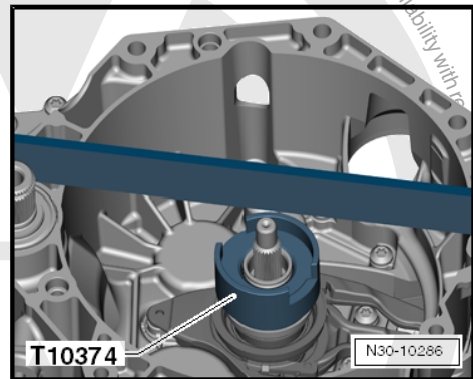

- Place digital depth gauge "at top" onto outer input shaft.
- "Zero" depth gauge.

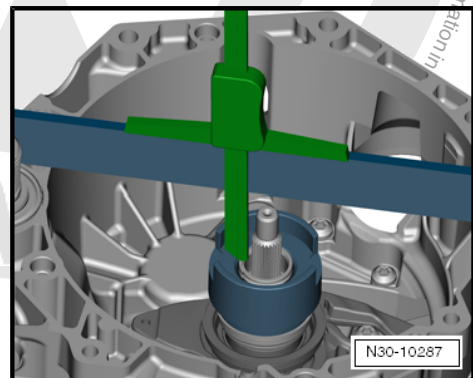

- Measure distance from "shaft end" into gauge block -T10374- .

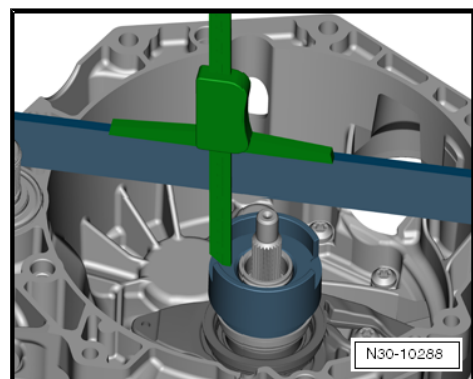



- Remove clutch again in this case => [page 8](#) .
- Look at shims -arrows- precisely.
- Shims must be correctly seated. They must not be damaged.

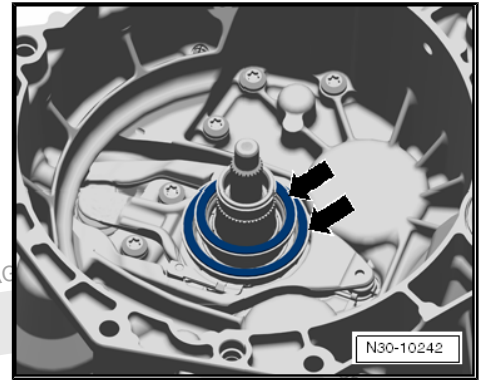

- Remove plugs and put both breather caps -arrows- back on.

After the gearbox has been installed, you must initiate a basic adjustment using the => Vehicle diagnosis, testing and information system VAS 5051 => [page 7](#) .

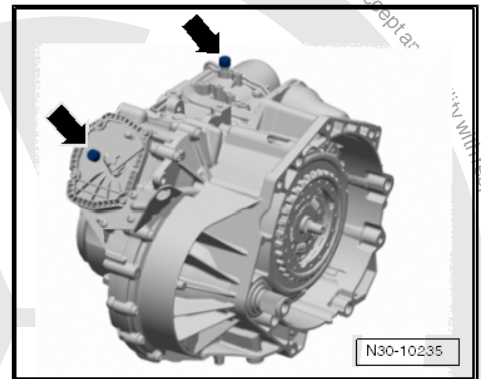



- Ensure that selector lever cable is properly routed during installation.

If the sheet metal is bent downwards, it may cause noises. The cable will vibrate against the sheet metal.

- Observe sheet metal. Press it back up in the tunnel during installation.

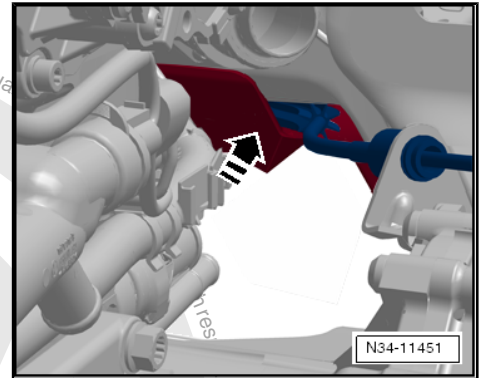

Loosen adjustment screw -arrow-.

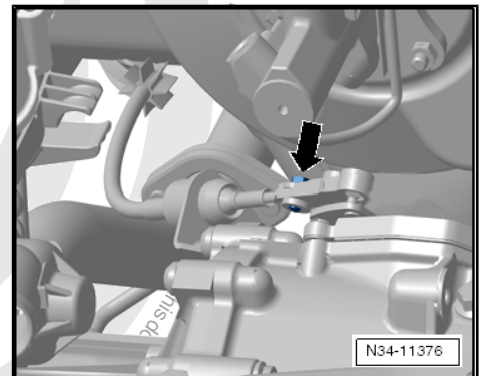

- Put selector housing onto cable.

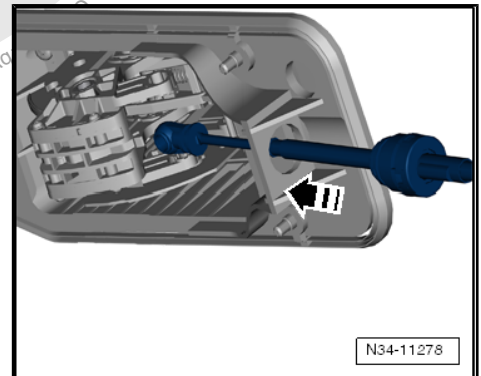

- Insert selector lever cable into selector mechanism.
- Insert cable into bearing and insert pin from above, downwards through eye.

When you have checked freedom of movement of cable  
⇒ [page 43](#) , insert locking plate.

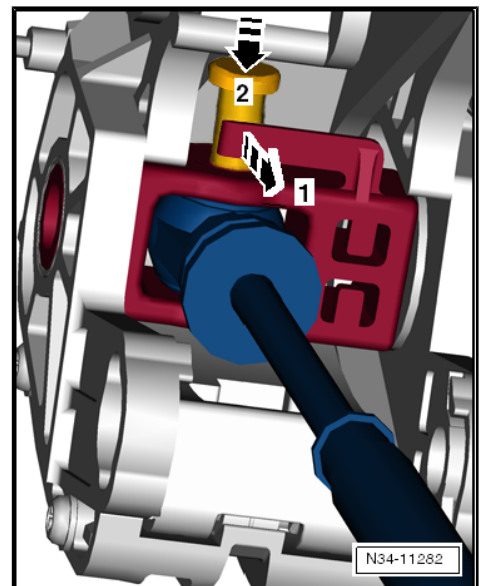

- Attach cable with new locking plate on cable support bracket of selector mechanism.



This figure shows you the view of gearbox from “behind”. -P- in direction of cable support bracket.

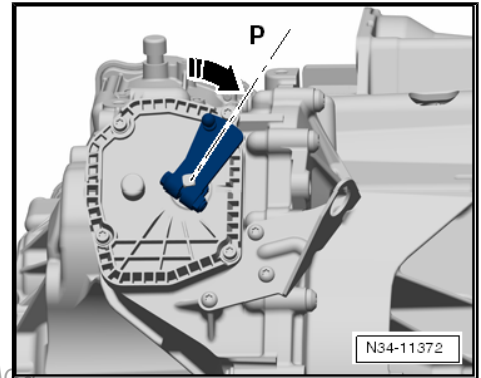

- Install Bowden cable with loosened adjusting screw -arrow- and new securing clip.



**WARNING**

***Be sure that the parking lock is engaged.***

- To do this, turn both front wheels simultaneously “under the car” in the same direction until the parking lock can be head to engage.
- The parking lock is engaged when both front wheels cannot be turned in the same direction at the same time.
- Gently push handle of selector lever forwards and backwards but under no circumstances must you shift out of “P”.

In this way the inner cable of the Bowden cable finds it optimal position.

- Tighten adjusting screw -arrow- to 13 Nm.

This completes the adjustment.

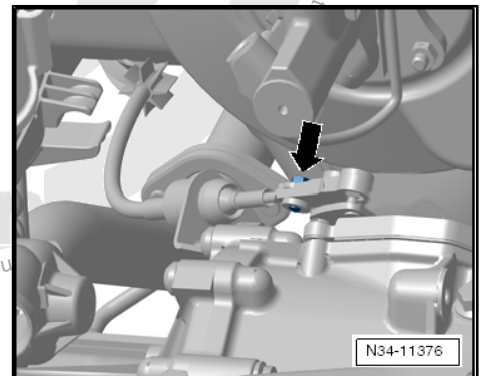
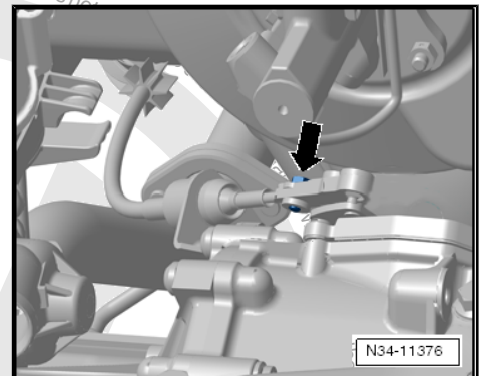





**WARNING**

*Do not work on pressure accumulator. The accumulator is under pressure and is not allowed to be opened.*

### 3.2 Overview - mechatronic unit

#### 1 - Bolt

- 10 Nm
- M8 x 35
- Always renew



**Note**

#### 2 - Bolt

- 10 Nm
- M8 x 90
- Always renew

#### 3 - Mechatronic unit for dual clutch gearbox -J743-



**Note**

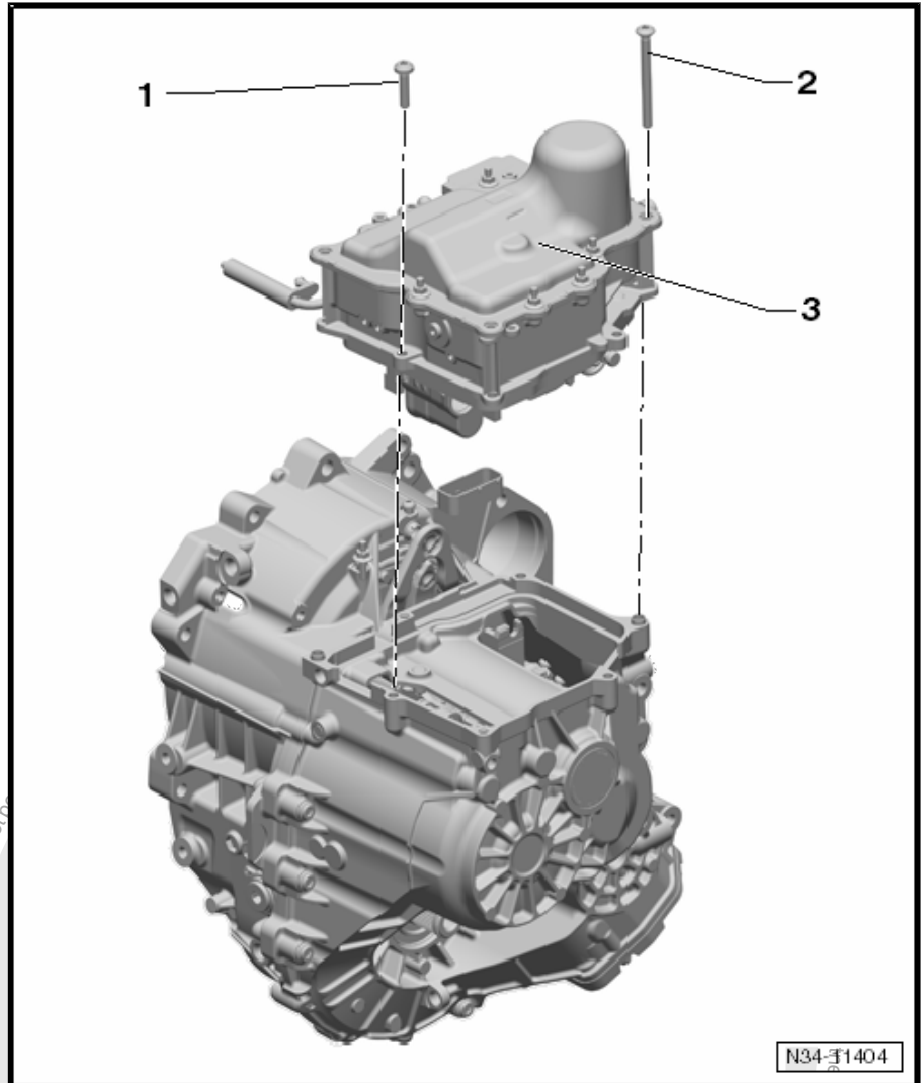

Take care with the breather when handling the mechatronic unit.

- When doing any work on the mechatronic unit, please remove cap -arrow- from breather and seal with a suitable plug.

Protective cover -0AM 325 120- is well suited.

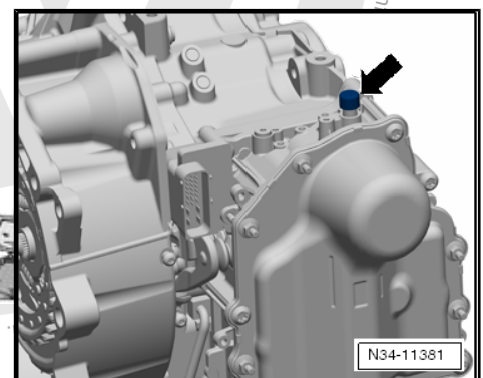

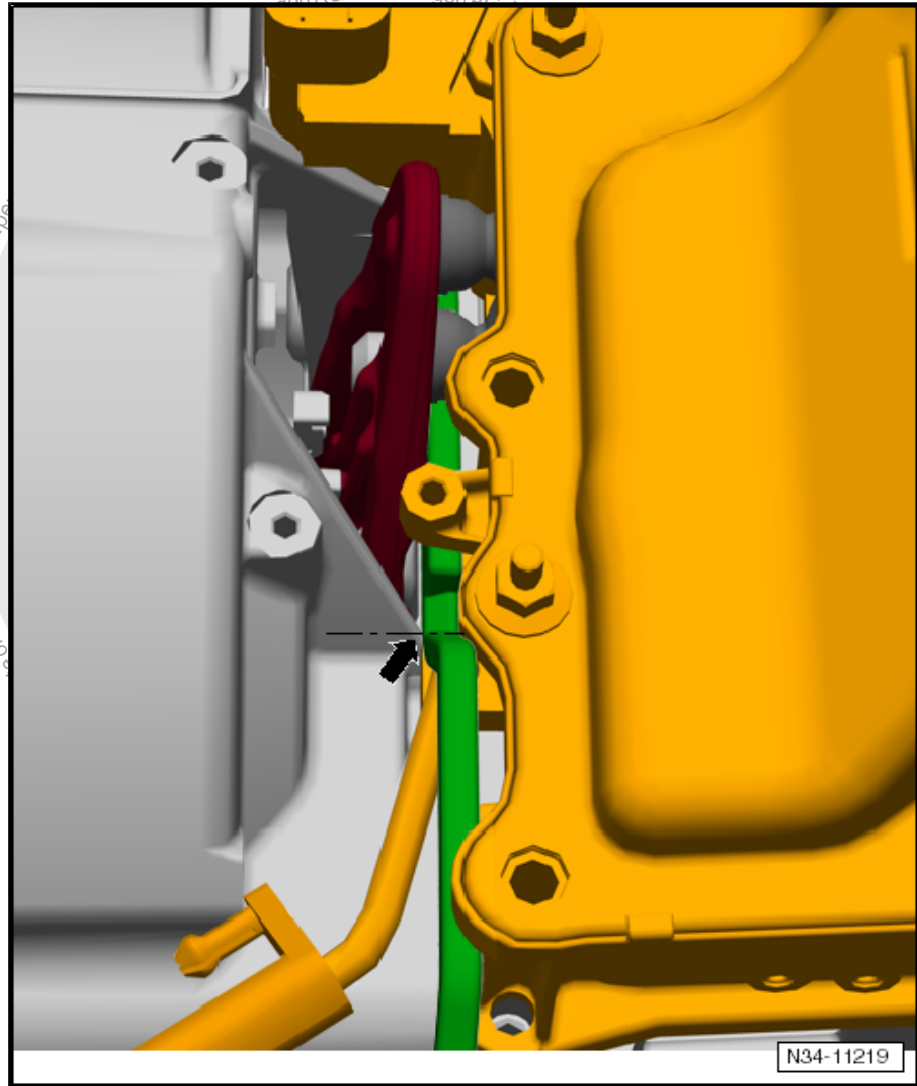

No further.

- Assembly lever -T10407- should make contact with gearbox housing with its entire "rear face".



**Caution**

- *Housing rib and groove of lever must be flush with one another. Do not insert tool as far as stop.*

- Apply a bit of force to tip of lever when turning.  
This stops lever from slipping out when turning.

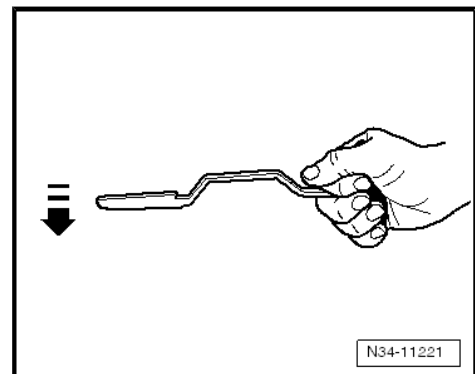



- Remove securing clip in -direction of arrow-.

Securing clips for selector lever cable must always be renewed.

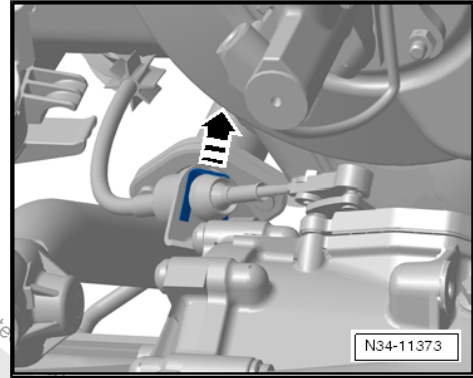

- Remove Bowden cable from ball head.
- Use your hand to press lever to stop in direction of cable support bracket.

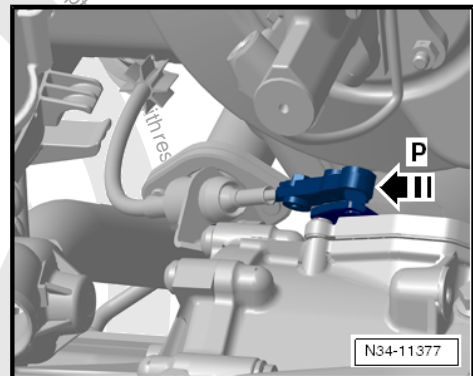

- Remove lever of selector shaft.
- Unbolt cover.

**Caution**

*The mechatronic unit will not be "stuck" after the next step. That means that it could fall out. If not already done: Secure mechatronic unit on gearbox with a bolt to prevent it from falling down.*

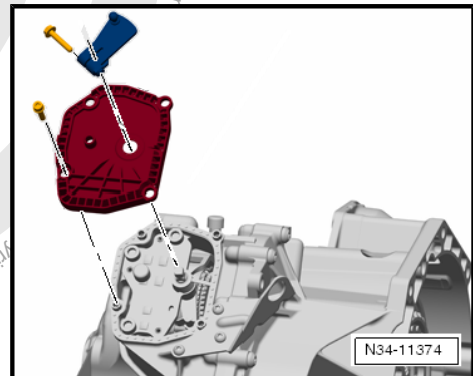

- Working through opening, push selector fork to side -direction of arrow-.

(Press to left in direction of travel.)

This presses back "sticking" gear actuator and mechatronic unit can be removed.

- Please do not assemble parking lock until you have filled oil.

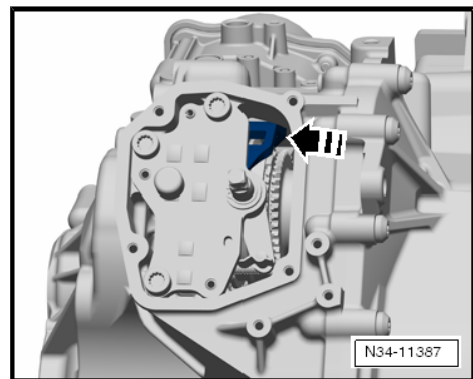



## 4.2 Removing gearbox, vehicles with 1.4 I/90 kW TFSI engine and 1.4 I/118 kW TSI engine

### Special tools and workshop equipment required

- ◆ Support bracket -10 - 222 A-
- ◆ Adjustment plate -3282/59-
- ◆ Adapter -10 - 222 A /8-
- ◆ Insert tool, 18 mm -T10179-
- ◆ Gearbox support -3282-
- ◆ Socket -T10061-

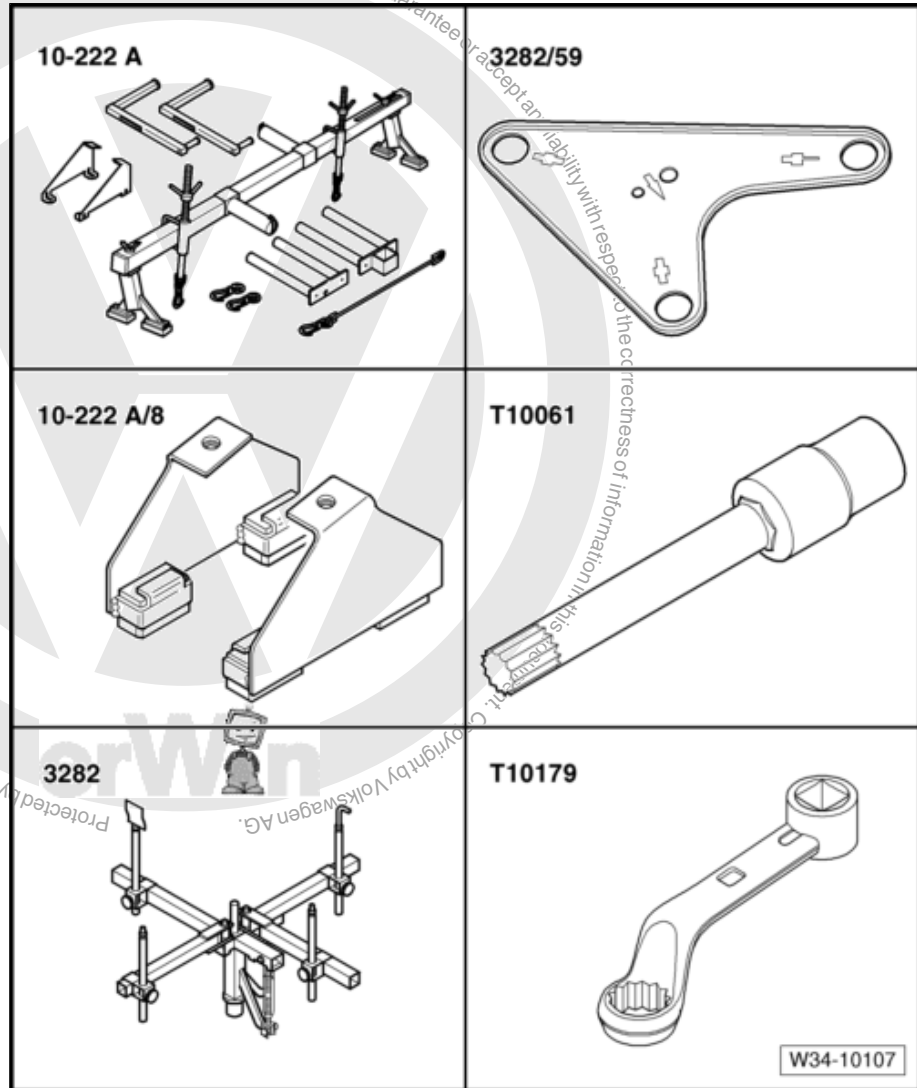

- ◆ Engine and gearbox jack -V.A.G 1383 A-

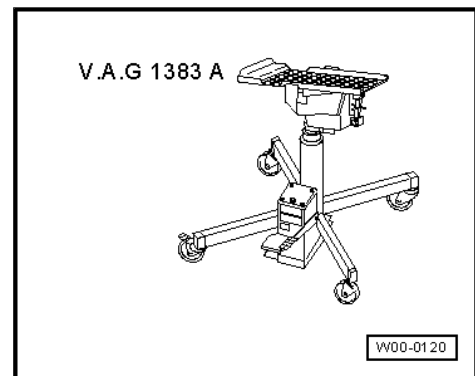

### Brief description

The gearbox is removed downwards separately, without engine.

The battery, air filter and starter are removed "from above".

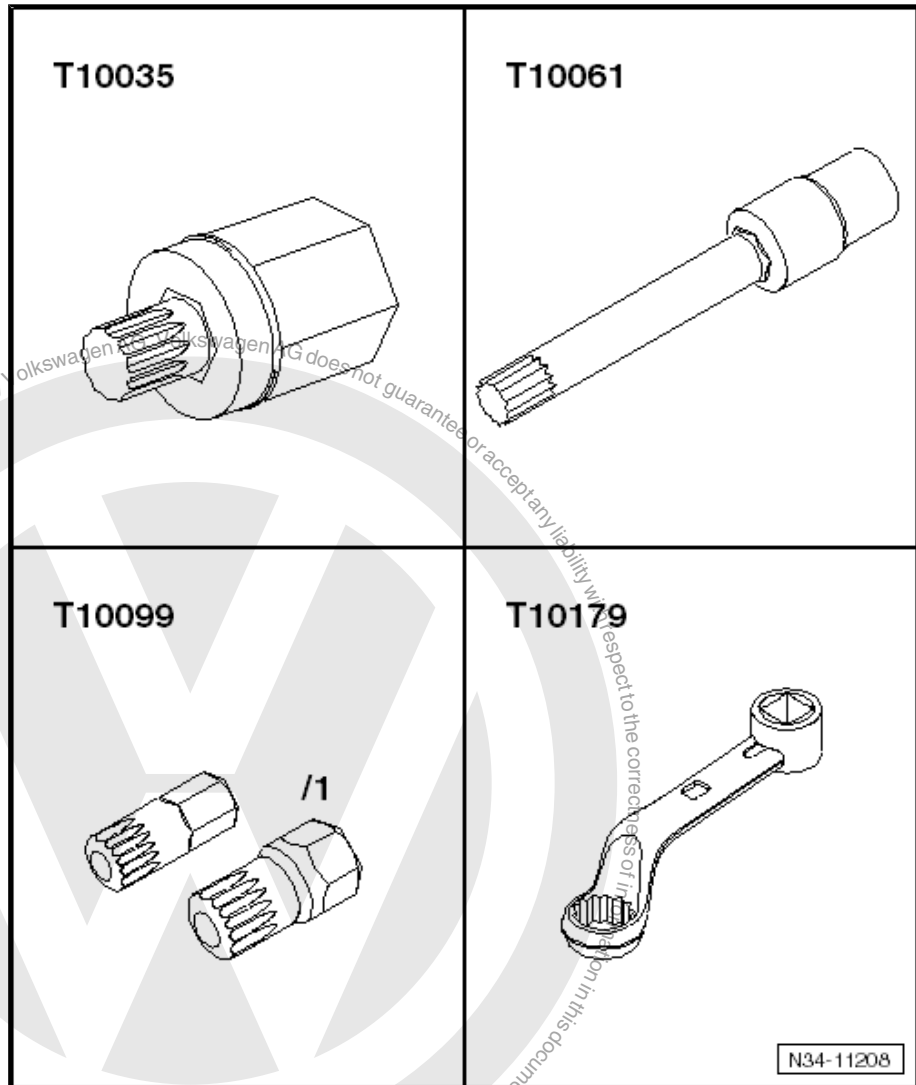

A bolt is located in the starter motor hole. Bit -T10061- can be used instead of an 18 mm socket.

- Remove noise insulation ⇒ Rep. Gr. 50 ; Assembly overview - noise insulation .
- Remove front part of wheel housing ⇒ Rep. Gr. 66 ; Assembly overview - front wheel housing .

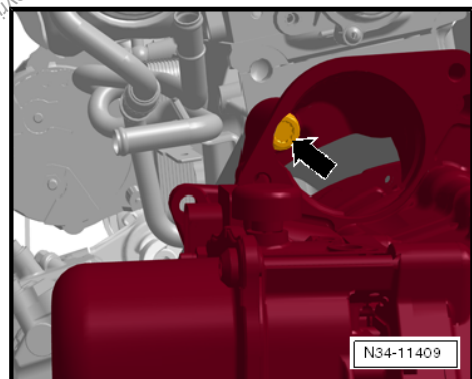



◆ Hook -10 - 222 A /2-

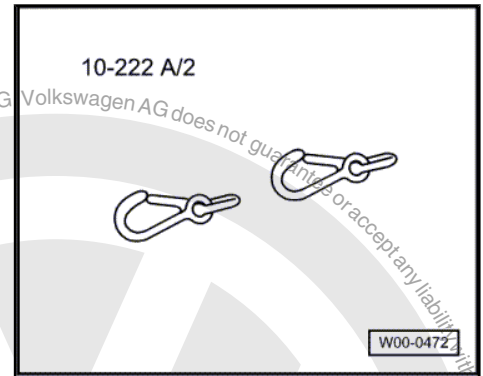

◆ Shackle -10 - 222 A /12-

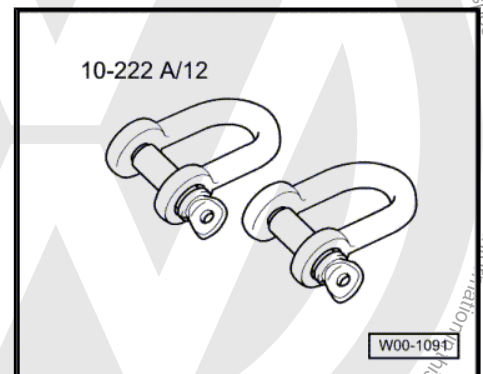

◆ Engine and gearbox jack -V.A.G 1383 A-

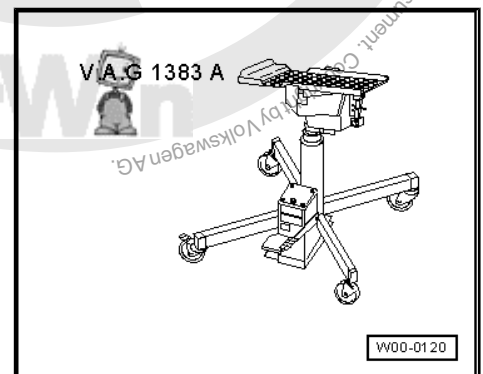

**Brief description**

The gearbox is removed downwards separately, without engine.

The battery, air filter and starter are removed "from above".

Noise insulation beneath engine/gearbox, lower cover in front left wheel housing and pendulum support are removed "from below".

**Perform the following steps:**

- Raise vehicle. All 4 supports of lifting platform must be at same height.
- Move selector lever to position "P" position.

**Only in vehicles with stub shafts**



**Note**

*After loosening centre bolt, do not lower vehicle to ground again.*



Remove all bolts -1- and -2- for bracket.

- Then lower engine and gearbox slightly using spindles of support bracket -10 - 222 A- so that bracket can be removed.

At most, 5 turns are sufficient to remove bracket.

In many cases, the spindle does not need to be lowered further for the later removal of the gearbox.

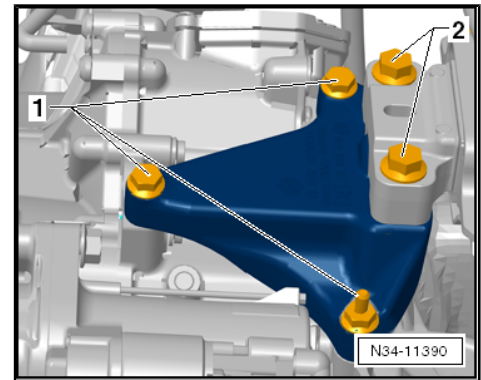

To remove gearbox 0AM, set up gearbox support -3282- with adjustment plate -3282/59- and push onto engine and gearbox support -V.A.G 1383 A- .

- Align arms of gearbox support according to holes in adjustment plate -3282/59- .
- Screw in support elements as illustrated on adjustment plate -3282/59- .
- Position engine and gearbox jack -V.A.G 1383 A- under vehicle.
- Arrow on adjustment plate -3282/59- points in direction of travel.
- Align gearbox support -3282- parallel to gearbox.
- Screw pin -3282/29- into "rear" hole for pendulum support.

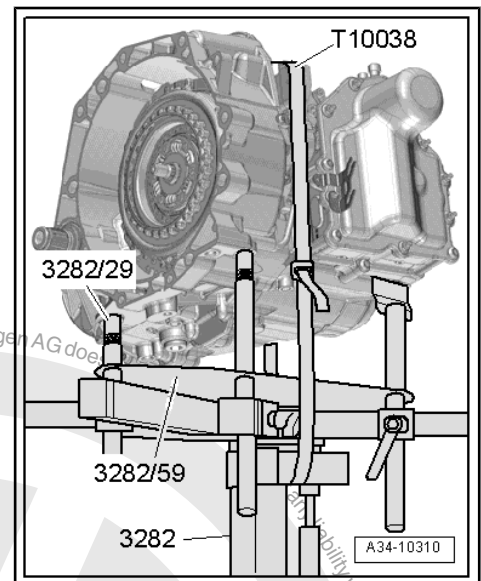

- Place both remaining attachments onto gearbox as shown. When doing this, place sheet metal of drift under gearbox housing and not under mechatronic unit.
- Secure gearbox with tensioning strap -T10038- .
- Raise gearbox and engine support -V.A.G 1383 A- from below to support gearbox.

The gearbox is separated from the engine in this position.

- Remove remaining engine/gearbox connecting bolts.
- Press gearbox off engine, "observing selector lever cable" and lower gearbox.

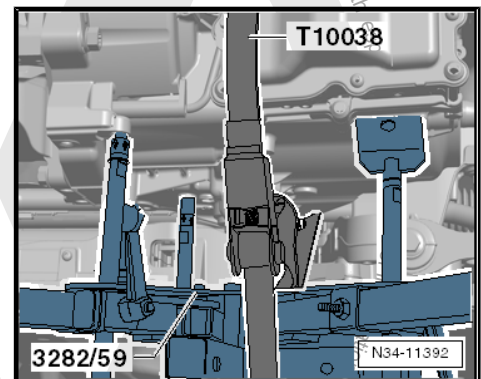

**i Note**

- ◆ Distance between engine flange and gearbox flange should be about 50 mm before gearbox is lowered.
- ◆ Be careful of all lines and coolant hoses when lowering gearbox.

