

51 11 993 Additional work: mounting the number plate baseplate/number plate

1 – Install the number plate baseplate for the number plate



WARNING

Malfunction of the sensors of the driver assistance systems.

Incorrect assembly of the number plate leads to a malfunction of the sensors of the driver assistance systems.

- Fix number plate and number plate baseplate only according to the dimensions specified in the repair instructions.
- Secure number plate and number plate baseplate on the bumper panel **without pre-drilling**, otherwise there is a risk of damage to the underlying cables.
- Only use number plate baseplates that have been approved for the vehicle type.



TECHNICAL INFORMATION

The number plate must be precisely mounted on the number plate baseplate and must not protrude on the underside.

The number plate carrier must not be installed on the front bumper.



TECHNICAL INFORMATION

In the European version with basic bumper panel, the number plate is installed without number plate baseplate.

► Positioning the number plate

- Position the number plate or number plate baseplate correctly.
- Make sure that the angle of radiation of the ACC sensor (1) is not obstructed.
- Make sure that the angle of radiation of the front camera (2) is not obstructed.

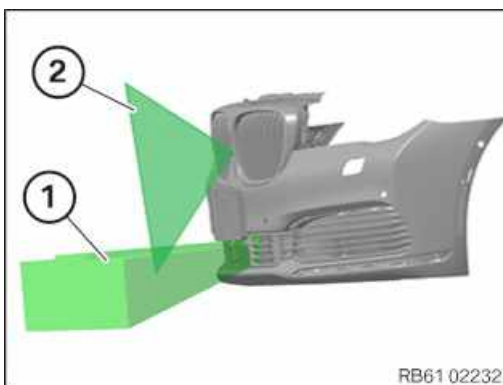

► Detect possible fault pattern due to incorrect assembly and rectify

Check

- Check number plate for correct position.

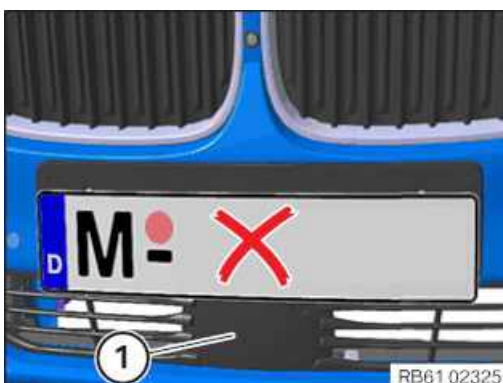

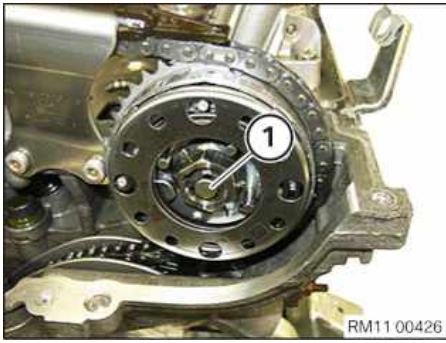

- Abut VANOS central valve (1) of exhaust side.

74 – Install VANOS central valve of the exhaust side

VANOS central valves

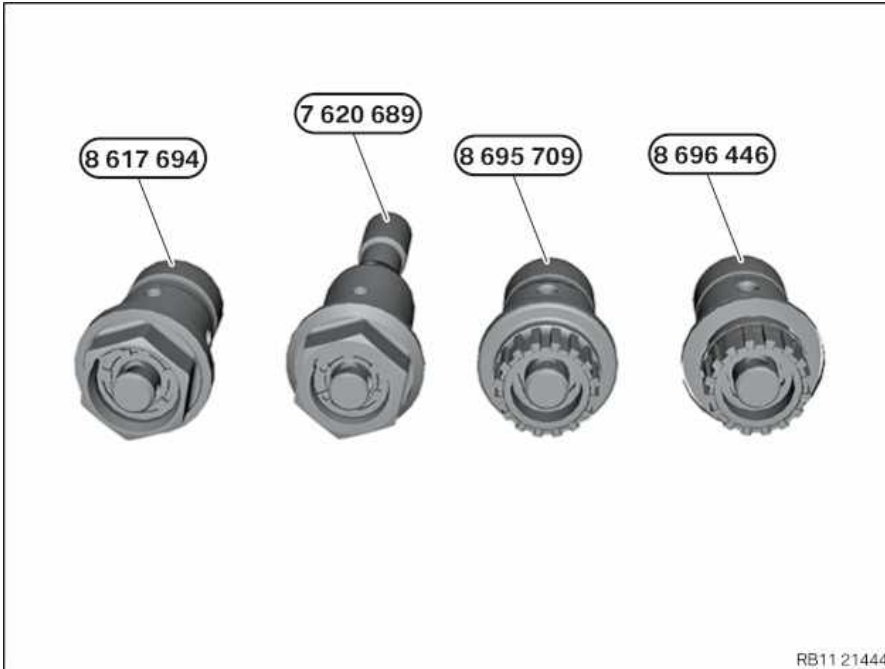

Overview graphic of the VANOS central valve

8 617 694 Brief VANOS central valve

7 620 689 Long VANOS central valve

8 695 709 VANOS central valve (increased leakage) (TZV)

8 696 446 VANOS central valve (low leakage) (TZV)



TECHNICAL INFORMATION

After replacing one or more VANOS central valves or VANOS adjuster:

During removal, note the identification/part number of the VANOS central valve or VANOS adjuster and write it down.

A VANOS adjuster and/or central valve with the same part number must always be reinstalled. Mixed installation is not permitted.

Read out I level of the vehicle and the proceed accordingly.

It is imperative to observe Product and Measures Management Aftersales measure 64122020.

For further information, see the EPC (Electronic Parts Catalogue)



- Mount and abut VANOS central valve (1) of exhaust side.



- Turn the actuator (1) on the exhaust side with the special tool [2 360 895](#) by about 50° in the direction of the arrow and remove it.

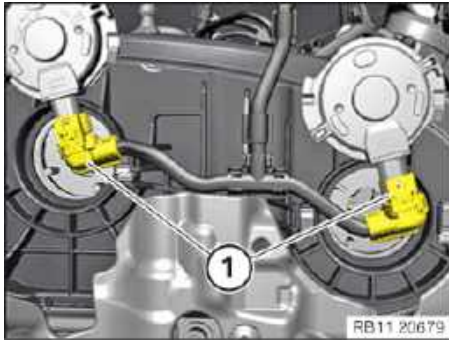

NOTICE

The figure shows the rear side of the engine.

- Unlock and disconnect both connectors (1).
- Feed out and remove both actuators.

25 – Remove ignition coils



WARNING

Hot surfaces.

Risk of burning!

- Perform all work only on components that have cooled down.



RISK OF DAMAGE

Damage to the ignition coil.

The silicone hose of the ignition coil must not be contaminated by fuel as this can lead to failure of the ignition coil.

- Cover ignition coils using suitable covers when working on the fuel system, if necessary remove them.
- Do not oil or grease the silicone tube of the spark plug connector. The silicone tube is coated with talc to reduce the pulling forces.



RISK OF DAMAGE



Electrostatic discharge.

Damage to or destruction of electrical components.

- Leave electrical components in original packaging until just before they are installed. Use the original packaging only for any return shipments. Always package removed components straight away.
- Read and comply with user information on using the associated special tool 12 7 060.
- Only touch the housings of electrical components. Do not touch pins or multi-pin connectors directly.
- Wear electrically conductive clothing and antistatic shoes (with ESD symbol).
- For additional information see: 61 35 Information on electrostatic discharge (ESD) protection.



NOTICE

The description is for one component only. The procedure is identical for all further components.

33 – Remove oil sump

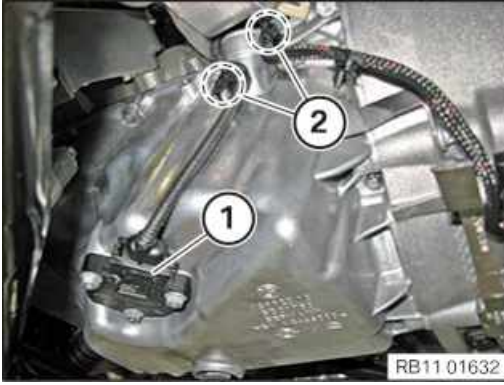

- Unlock and disconnect connector (1).
- Release the cable from the clips (2) of the oil sump.

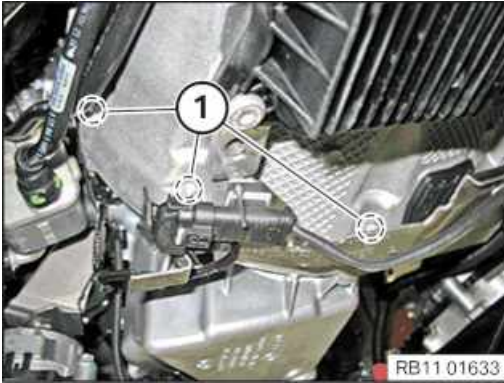

- Unscrew the transmission bolts (1).

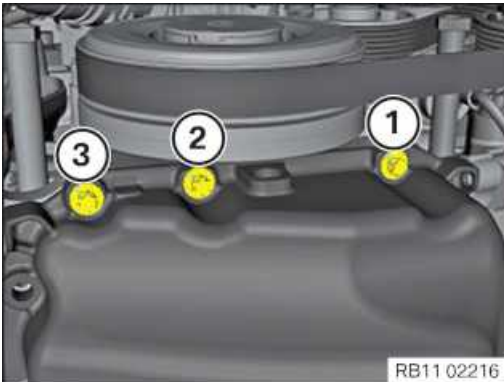

- Loosen screws (1), (2) and (3).

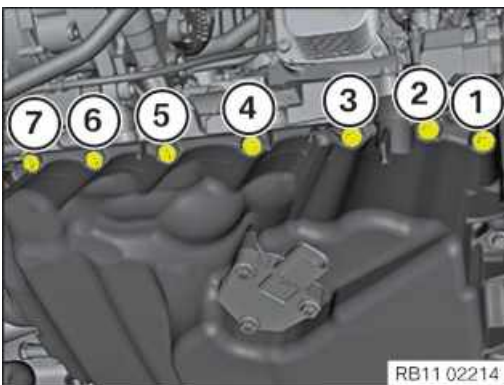

- Loosen screws (1) to (7).

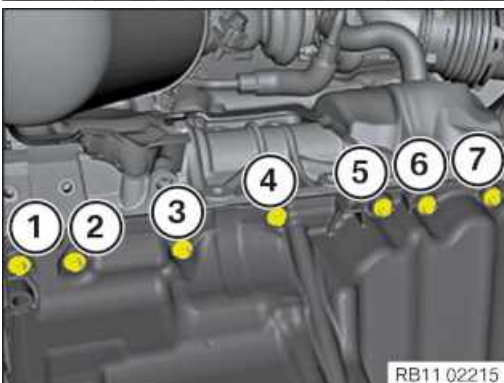

- Loosen screws (1) to (7).

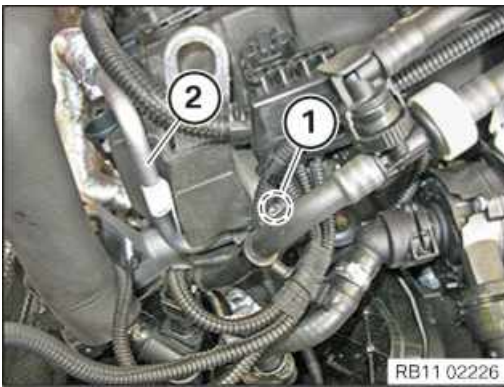

- Have a rag ready and make sure that no engine oil drips onto the belt drive.
- Loosen screw (1).
- Pull off the oil feed line (2).

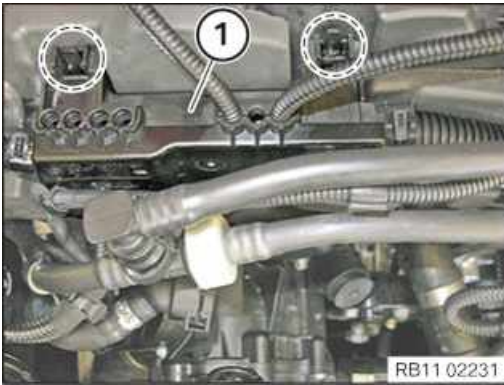

- Unlock and pull off the engine wiring harness (1) in the highlighted areas.

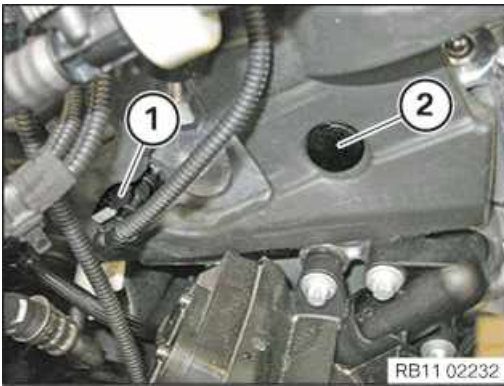

- Unlock and disconnect connector (1).
- Loosen expanding rivet (2).

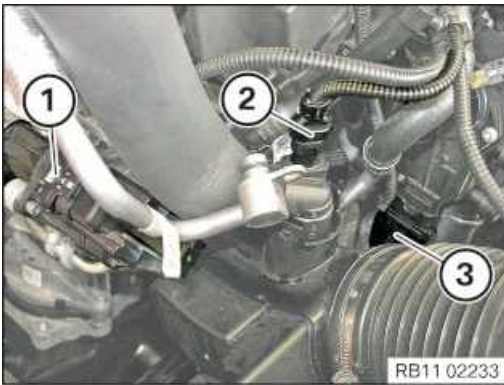

- Unlock the connector (1) and pull it off the exhaust turbocharger.
- Unlock the connector (2) and pull it off the heating element.
- Unlock the connector (3) and pull it off the heat management module.

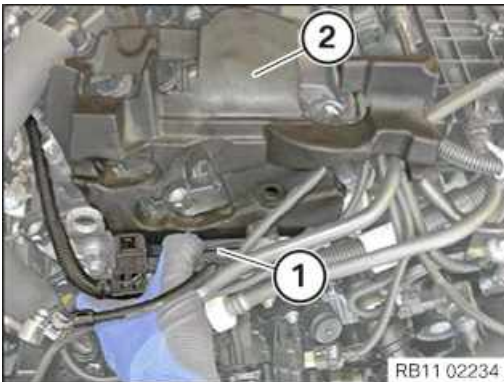

- Carefully pull the engine wiring harness (1) toward the front and feed the engine encapsulation (2) out toward the top.

10 – Remove the oil feed line for the exhaust turbocharger (engine encapsulation removed)



WARNING

Falling or tipping of a heavy component.

Danger! Life-threatening injuries!

- Before lowering or removing the front axle: Secure the engine in mounting orientation.
- For additional information see: 11 00 670 Securing engine in installation position.

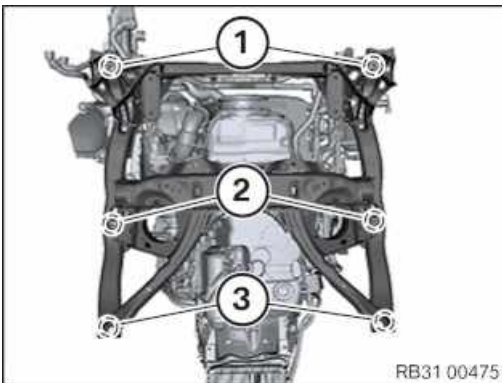
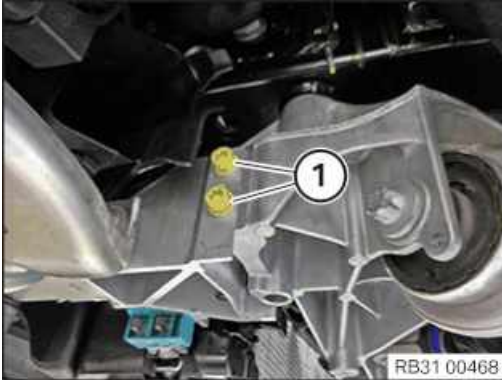

NOTICE

Perform the operations on the left and right side.

- Loosen screws (1).

- Loosen screws (1) to (3).

35 – Lower front axle support

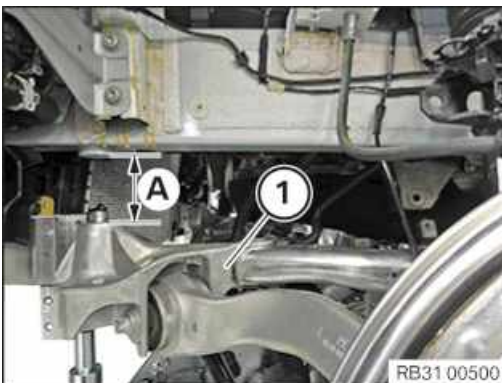

- Lower the front axle support (1) by dimension (A).
Dimension (A) = maximum of 10 cm

36 – Remove the acoustic cover of the oil sump

- ▶ Remove the acoustic cover of the oil sump



- **Top up the automatic transmission fluid:**
- Loosen the oil filler plug (1) using the special tool [2 405 614](#).
- Top up automatic transmission fluid according to the instructions in the diagnosis system.

GA8HP51Z transmission capacity

min. 9,28 l
Transmission oil: Automatic transmission fluid ATF 3+

GA8HP76Z transmission capacity

min. 9,35 l
Transmission oil: Automatic transmission fluid ATF 3+

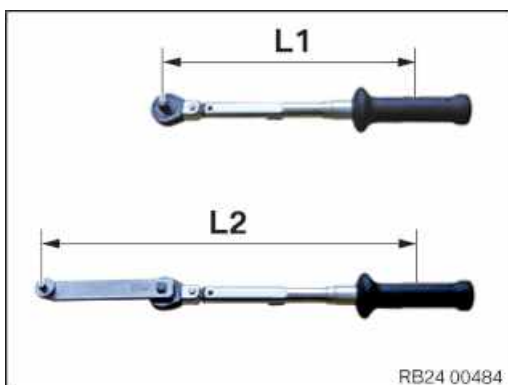

TECHNICAL INFORMATION

The setpoint torque deviates from the torque to be set when using special tool 2 405 614.

- **Converting the setpoint torque into the torque to be set:**

(setpoint torque x L1) : L2 = torque to be set.

L1 = Length from the centre of the handle to the reversible ratchet head

L2 = Length from the centre of the handle to the engaging of the special tool in the bolt.

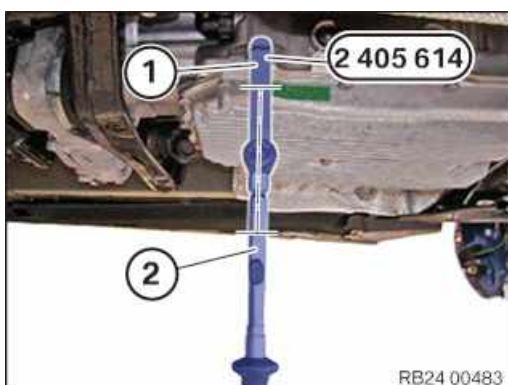

- Renew the oil filler plug (1) and the sealing ring.
- Parts:** Oil filler plug, sealing ring
- Make sure that the special tool [2 405 614](#) and the torque wrench (2) align while tightening the oil filler plug (1).
 - Tighten the oil filler plug (1) with the special tool [2 405 614](#) and the torque wrench (2).

Oil filler plug

M18x1.5	Tightening torque	35 Nm
---------	-------------------	-------

8 – Installing the centre underbody protection



NOTICE

To provide a better overview: Schematic diagram with partially hidden components.

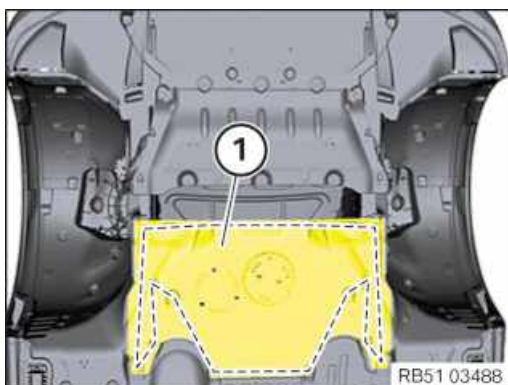

- Insert the centre underbody protection (1).
- Tighten the screws along the dotted line.

Underbody protection

Screw	Tightening torque	3 Nm
-------	-------------------	------

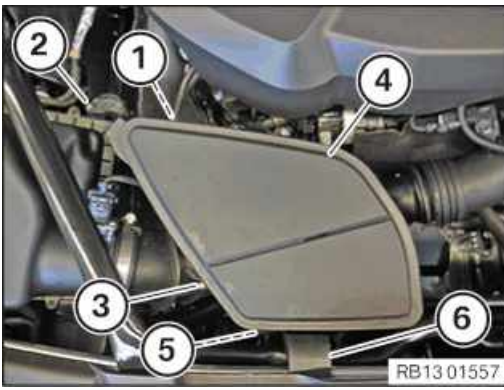

- Loosen clamp (1).
- Loosen screw (2).
- Unfasten clamp (3).
- Make sure that the holder (6) is not damaged while removing the resonator (4).
- Feed the resonator (4) out of the rubber mount (5) out to the top and remove.

► **Removing left and right front-end strut**



NOTICE

Description is for left component only. Procedure on the right side is identical.

► **Removing the front-end strut**

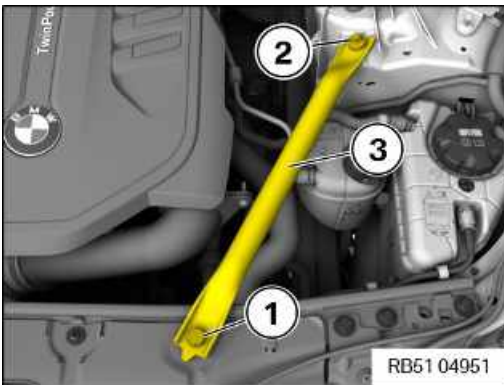

- Loosen screws (1) and (2).
- Remove the front-end strut (3).

<

► **Remove front cross connection**

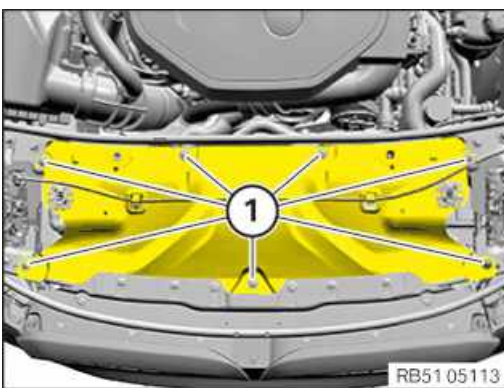

- Loosen screws (1).

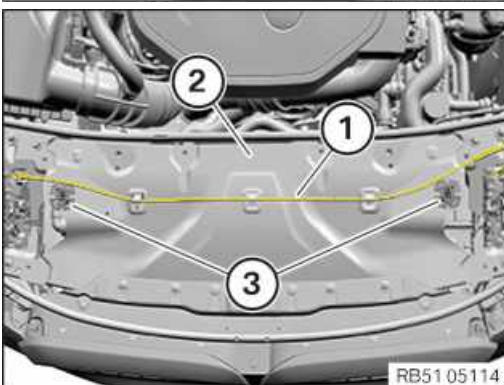

- Detach the Bowden cable (1).
- Feed out cross connection (2) with brackets (3) and remove.



RISK OF DAMAGE

Damage to the output flange.

Failure to observe the greasing specifications may lead to damage on the output flange.

- Do not contaminate the thread of the output flange with grease.

- Remove any adhesive residue on thread (1) of the flange and clean it.
- Clean gearing (2).
- Grease gearing (2).

Expendable materials

Lubricating grease Optitemp HT 1 LF	50 g, Tube	83230417754
-------------------------------------	---------------	-------------

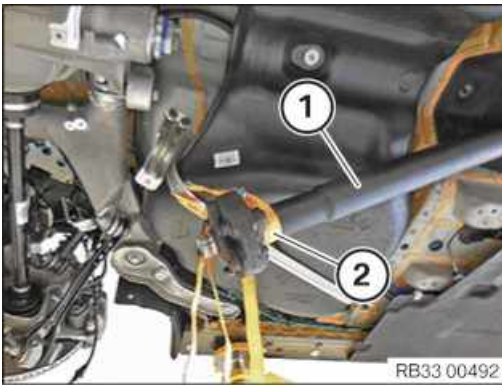

- Loosen the tensioning strap (2) from the propeller shaft (1).

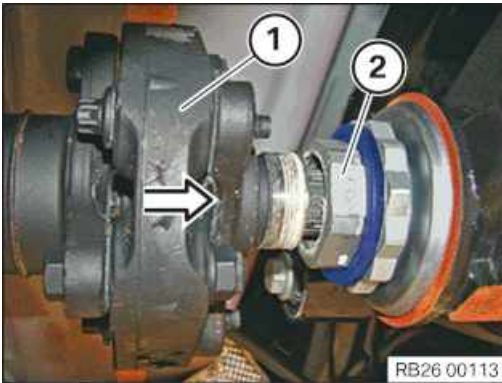

- Push the propeller shaft (1) in the direction of the arrow against the recessed nut (2) up to the limit position.
- Screw and secure recessed nut (2) at least 2 thread starts onto propeller shaft (1) by hand.

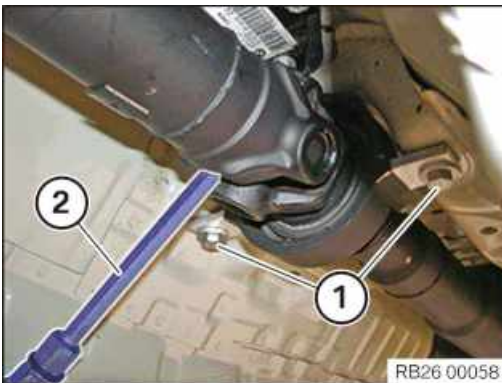

- Position centre mount.
- Position the screws (1) by hand.
- **Version A (propeller shaft with wide universal joint):**
Secure the propeller shaft against twisting at the central universal joint using a suitable tool (2).
Only tighten screws (1) when the propeller shaft is completely screwed into place.

34 35 001 Replacing a brake pad wear sensor (front)

PRELIMINARY WORK

1 – Removing the front left wheel

► Removing the wheel



- In vehicles with M Carbon ceramic brake: The wheel assembly jack must be used to remove the wheel (see workshop equipment).

This process is intended to prevent damage to the brake disc.



- If several wheels are removed simultaneously: Use a piece of chalk to mark on each tyre the axle and side on which the corresponding wheel is fitted.
- Release the wheel bolts (arrows) crosswise and remove the wheel.
- To release and tighten wheel bolts with a security code: Use a suitable adapter from the tool set .

MAIN WORK

2 – Remove brake pad wear sensor to the front



TECHNICAL INFORMATION

The brake pad wear sensor must be replaced once it has been removed because the brake pad wear sensor loses its retention capability in the brake pad.

If a brake pad wear sensor that has already been ground has to be replaced even though the minimum brake pad thickness has not yet been reached, you must observe the following:

The new sliding contact must be filed down with a file to the same length as the sanded sliding contact.

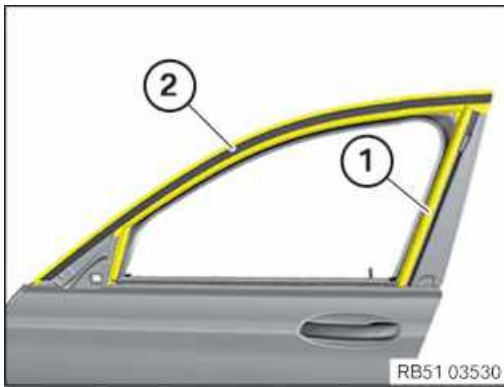

- Feed in rubber window seal (1) together with the top trim strip (2) on the door frame.
- Mount rubber window seal (1) on the trim strip (2).
- Coat rubber window seal (1) with suitable lubricant.
- Retract rubber window seal (1), front and rear in the window guide.
- Ensure the weather-strip (1) is correctly positioned.

24 – Install the front door window glass (module carrier removed)

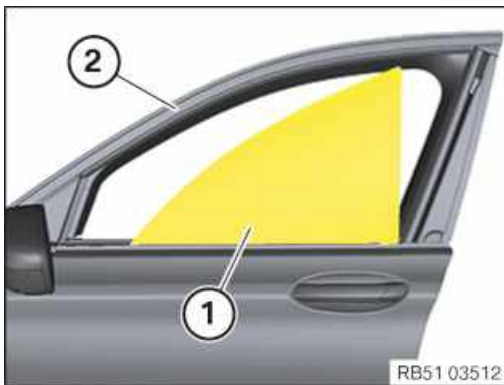

- Insert the twisted door window glass (1) into the door frame (2).
- Insert the door window glass (1) into the rubber window seals by twisting it.
- Push the door window glass (1) fully upwards and secure it to the door frame (2) using adhesive tape.

The door window glass (1) must be positioned correctly in the rubber window seal.

25 – Preserving the front door



NOTICE

Schematic diagram is for example purposes. Some parts may differ in certain details.

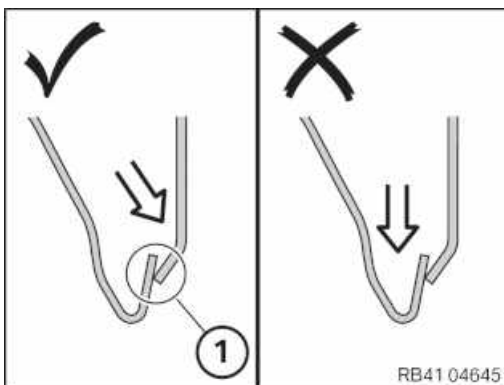

- The inner door panel is welded with the door outer skin in the area (1). The weld seam must be protected against corrosion by cavity preservation.

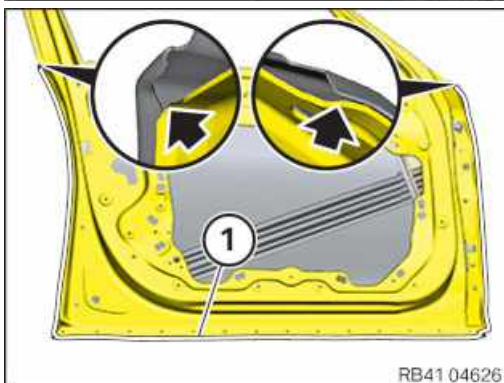

- Preserve the inner door panel in the area of the weld seam (1).
- Apply cavity preservation up to the two marked ends. Remove any cavity preservation which emerges.

6 – Install the weather strip on the front door

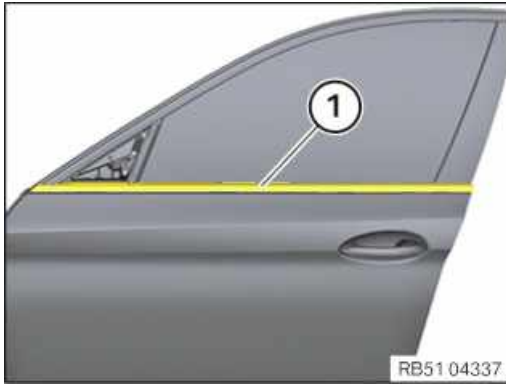

- Renew the weather strip.

Parts: Weather strip

- Coat the weather strip (1) with a suitable lubricant prior to installation.
- Install the weather strip (1) and align it to the door edges .
- Press down the weather strip (1) along its entire length.

7 – Fit exterior mirror

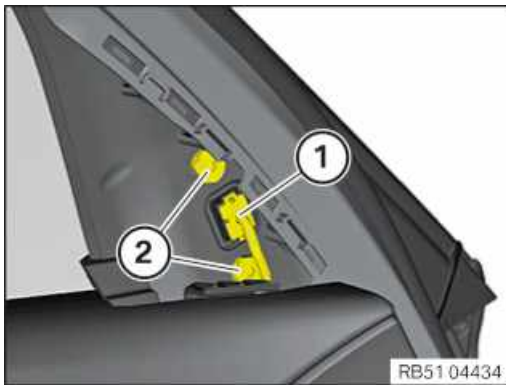

- Attach exterior mirror and secure it against falling out.
- Tighten down screws (2).

Exterior mirrors

	8 Nm
--	------

- Connect connector (1).

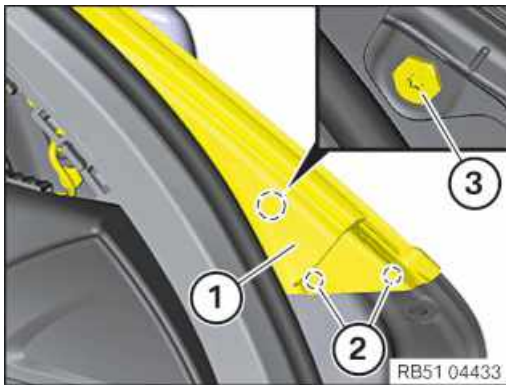

- Push the sealing (1) slightly to one side and tighten the screw (3).

Exterior mirrors

	8 Nm
--	------

- Secure the sealing (1) on the clips (2).

8 – Install the mirror triangle cover

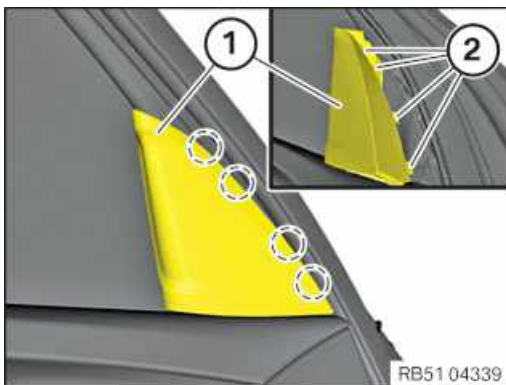

- If necessary, connect the connector to the mirror triangle cover (1).
- Insert the mirror triangle cover (1) and clip it into the latch mechanisms (2).

Additional Information

Overview of Tightening Torques

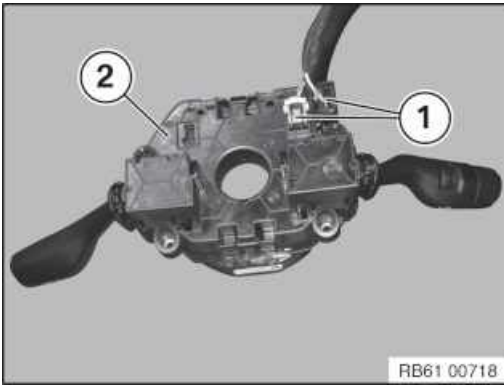

- Connect the connector (1) with the steering column switch cluster (SZL) (2).

► Check the neutral position of the clock spring

i
TECHNICAL INFORMATION
 Different variants may be installed depending on the vehicle equipment.

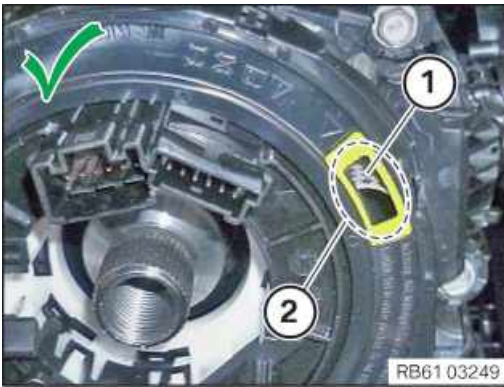

Check

- **Version A:**

Check the mark (1) on the coil spring in the inspection glass (2).

Result

» The mark (1) on the coil spring is not visible.

Measure

- Turn the coil spring cassette until the mark (1) on the coil spring becomes visible in the inspection glass (2).



Check

- **Version B:**

Check the mark (1) on the coil spring in the inspection glass (2).

Result

» The mark (1) on the coil spring is not visible.

Measure

- Turn the coil spring cassette until the mark (1) on the coil spring becomes visible in the inspection glass (2).

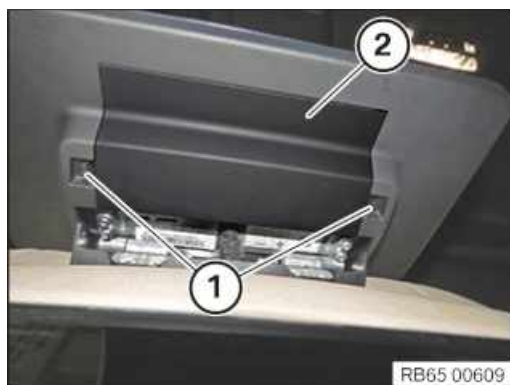

- Correctly position the cover (2) and engage in the latch mechanisms (1). Do not reuse any removed covers (2)!

Additional Information

Overview of Tightening Torques

Seat to body			Used in step	20
M10	Renew screw.	Tightening torque		42 Nm
End fitting to seat mechanism			Used in step	20
M10	Renew screw.	Tightening torque		42 Nm
Hinges on front seat			Used in step	21
		Tightening torque		2,1 Nm

Overview of Special Tools

0 492 668 (52 0 050) Pliers

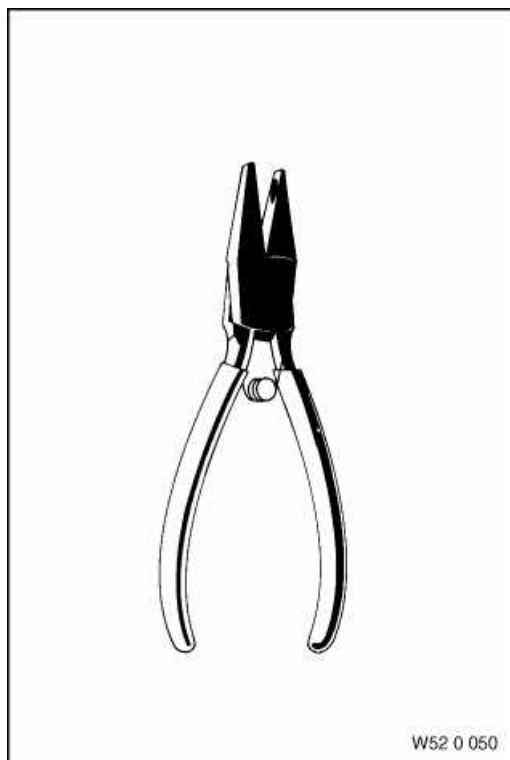

Common		Used in step	11
Usage	For securing clamps on seat cover		
Included in the tool or work			
Storage location	C14		
Replaced by			
In connection with			
SI-Number	52 06 87 (808)		

Links

General repair instructions	Used in step
72 00 ... Safety regulations for handling components with gas generators	220

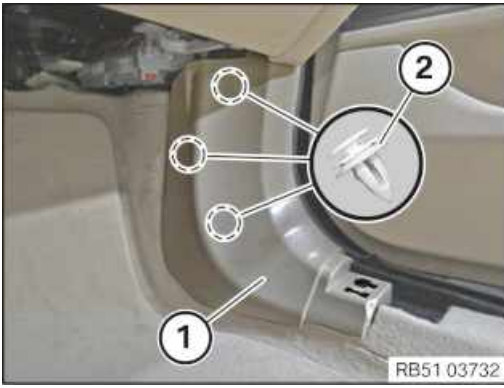

- Loosen the side trim panel (1) at the clips (2) and remove it toward the inside.

MAIN WORK

5 – Remove the BDC control unit

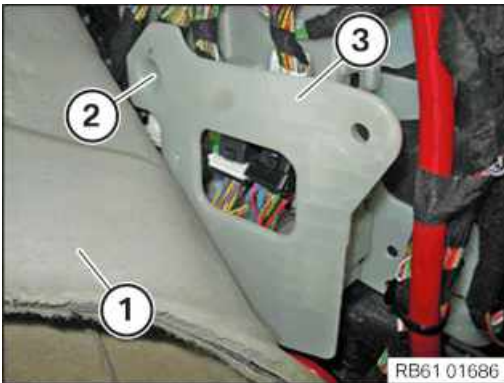

- Fold the carpet (1) to the side.
- Loosen screw (2) on the cover (3).

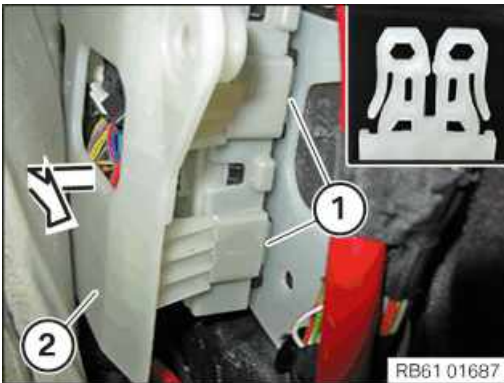

- Loosen the latch mechanisms (1).
- Guide cover (2) out in direction of arrow.

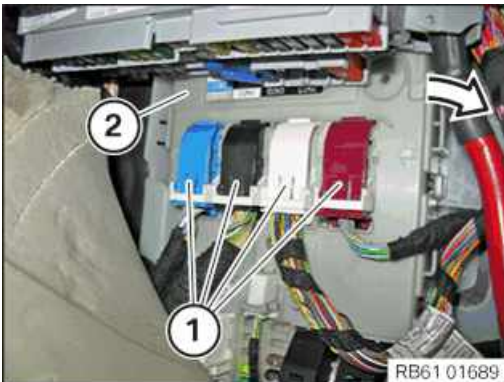

- Unlock and disconnect all connectors (1).
- Swivel the BDC control unit (2) slightly in the direction of the arrow.