

PRELIMINARY WORK

1 – Removing the acoustic cover



RISK OF DAMAGE

Damage to the acoustic cover/design cover.

Jerky movements during disassembly and excessive application of force during installation may result in breakage of the acoustic cover/design cover.

- Disassemble or mount the acoustic cover/design cover carefully.
- Disassemble or mount snap-lock couplings of the ball pivots one after the other.
- Disassemble or mount acoustic cover/design cover only at temperatures $>20\text{ }^{\circ}\text{C}$.
- Use only distilled water as an auxiliary material during installation, no lubricants.



- Unclip the acoustic cover (1) from the holders in the indicated area towards the top.

2 – Removing the oil filler cap



- Open oil filler cap (1).

MAIN WORK

3 – Remove oil filter



- Loosen the oil filter cover (1).



Engine identification



Engine number at the marked surface.

Replacement drives are already assigned a number containing the identification and engine number at the factory.

The old drive number must be imprinted for replacement crankcases.

Magnesium crank cases feature a label, the engine number does not need to be embossed.

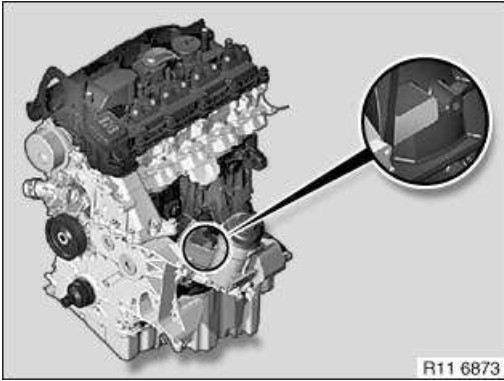

M47 / M47TU / M47T2

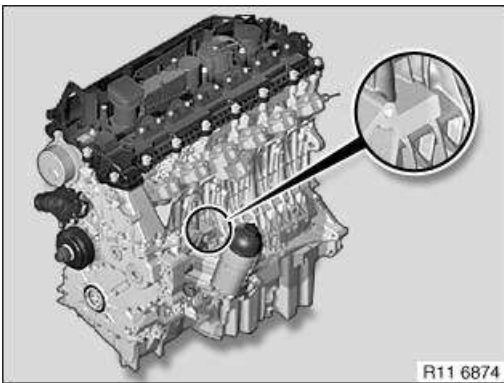

M57 / M57TU / M57T2

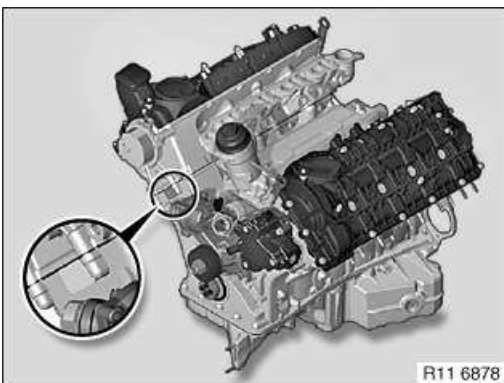

M67 / M67TU





- Check the sealing ring (1) on the exhaust turbocharger for damage and renew if necessary.

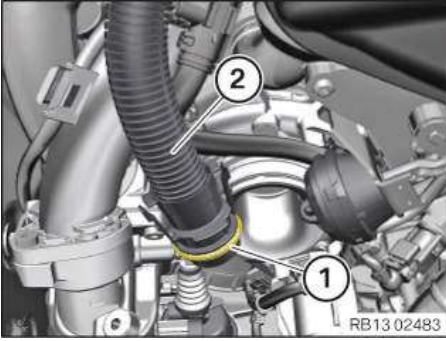

- Check the sealing ring (1) for the engine ventilation line (2) for damage and renew where required.



- Feed in and install clean air pipe with resonator (1) in the direction of the arrow.

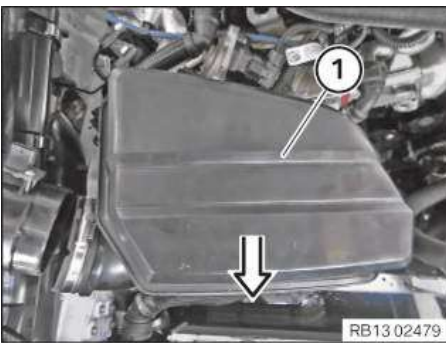

- Press and hold clean air pipe with resonator (1) in the direction of the arrow.



- Attach and lock the clamp (1).
The clamp (1) must engage audibly.

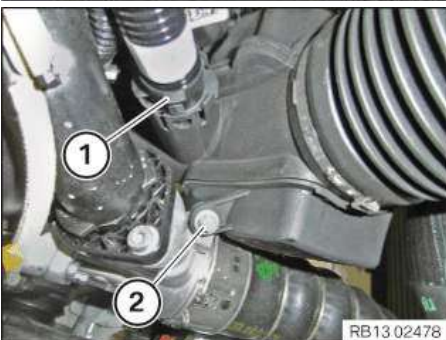

- Tighten down screw (2).

Clean air pipe to exhaust turbocharger

M6X20		Tightening torque	8 Nm
-------	--	-------------------	------



- Park vehicle on a horizontal surface.
- Stop the engine and wait for 5 minutes.
- Pull out the oil dipstick and wipe off using a lint-free cloth.



TECHNICAL INFORMATION

Do not pull out or insert the oil dipstick into the guide tube too quickly or slowly.

- Push the oil dipstick into the guide tube up to the limit position and pull it out again.



TECHNICAL INFORMATION

The engine oil level must be between the minimum mark and the maximum mark of the oil dipstick.

- Read the engine oil level on the oil dipstick.
- Top up engine oil if necessary.

Oil quantity between the two markings MIN and MAX of the oil dipstick

1.0 l

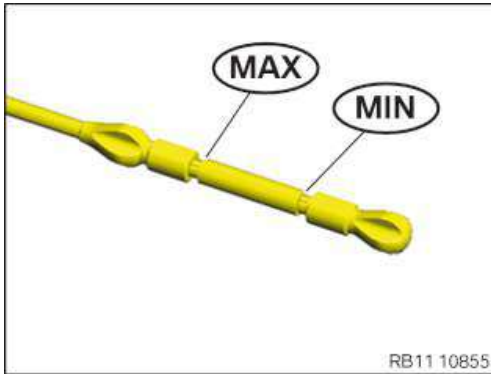

3 – Removing the oil filler cap



- Open oil filler cap (1).



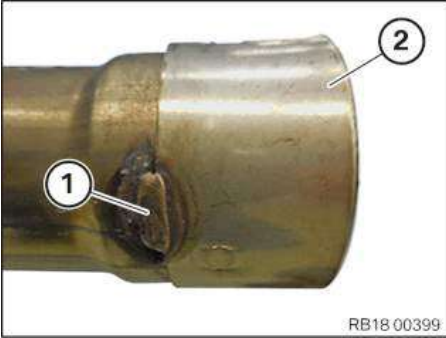
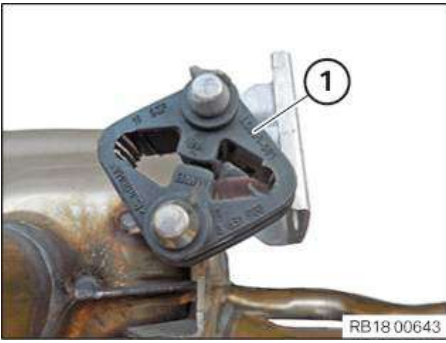

NOTICE

Schematic diagram is for example purposes. Some parts may differ in certain details.

- Check all the rubber mounts (1) of the exhaust system for damage.
- Replaced damaged rubber mounts.

Parts: Rubber mount



CAUTION

Swarf resulting from sawing or grinding components.

Danger of injury!



- Conduct all work in appropriate personal protective equipment only.



- Wear safety goggles and protective gloves.

- Open the weld seam (1) with a conventional tool.
- Remove the clamp (2).

- Insert and install the exhaust system (2).
- Renew nuts (1).
- Tighten nuts (1).

Parts: Nuts

Rear silencer to body / bumper support

M8	Replace nuts.	Tightening torque	19 Nm
----	---------------	-------------------	-------

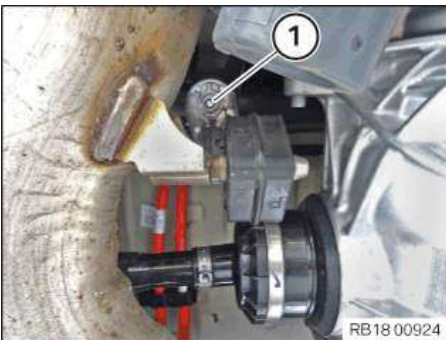
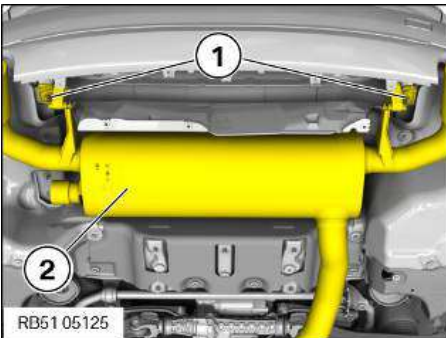

- Renew nut (1) on the rear axle support.
- Tighten nut (1).

Parts: Nut

Exhaust system to rear axle carrier

M8 nut		Tightening torque	19 Nm
--------	--	-------------------	-------

- Tighten nut (1).

Exhaust system to transmission

M8		Tightening torque	19 Nm
----	--	-------------------	-------

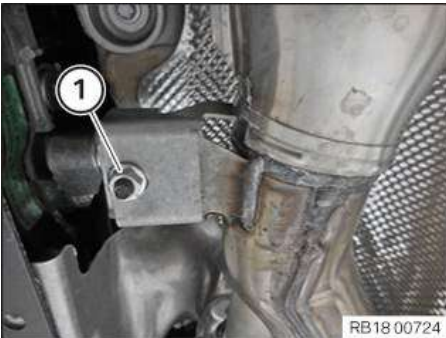

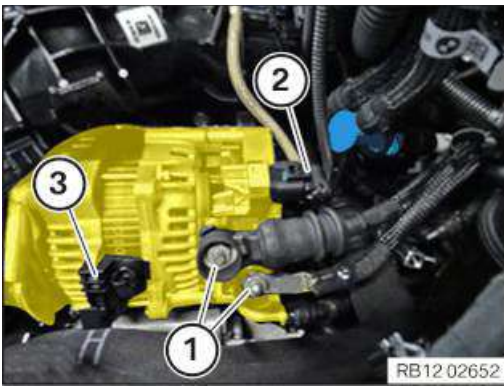

- Fasten the holder (3).
 - Connect connectors (2) and lock.
The connector (2) must engage audibly.
 - Renew nuts (1).
- Parts:** Nuts
- Tighten nuts (1).

Battery positive lead on the starter motor generator

M8	Tightening torque	19 Nm
----	-------------------	-------

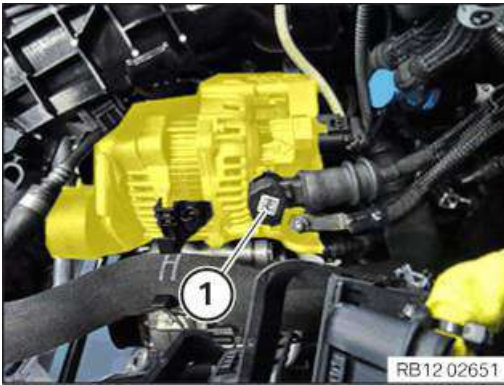

- Guide in and install the lid (1).

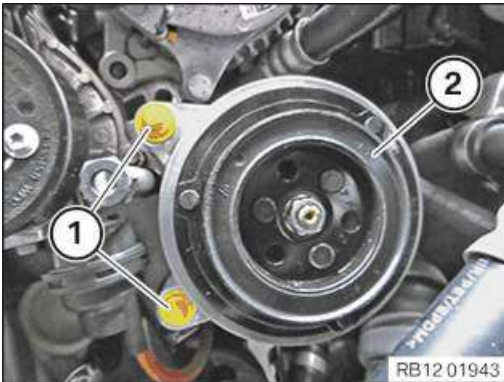

- Insert and install the air conditioning compressor (2).
- Tighten the screws (1).

Air conditioning compressor in component carrier

M10	Tightening torque	38 Nm
-----	-------------------	-------

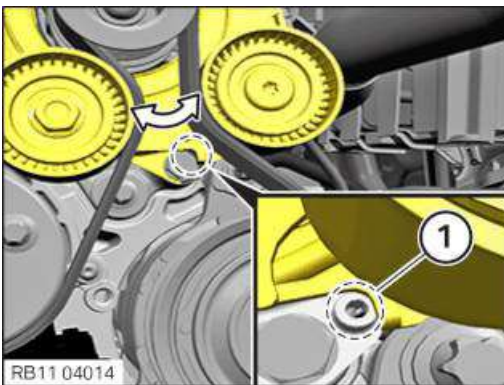

- Position the belt tensioner so that the bore hole is visible in the area (1).

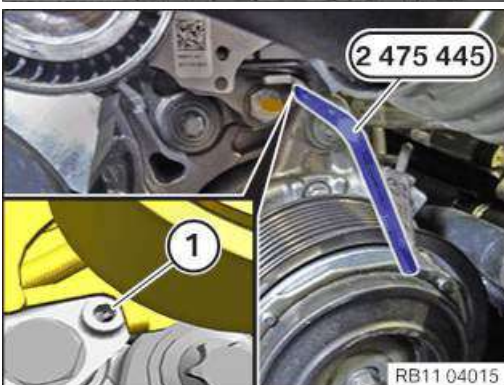

- Guide in the special tool [2 475 445](#) and install it in the bore hole (1).
The special tool [2 475 445](#) must rest against the starter motor generator.



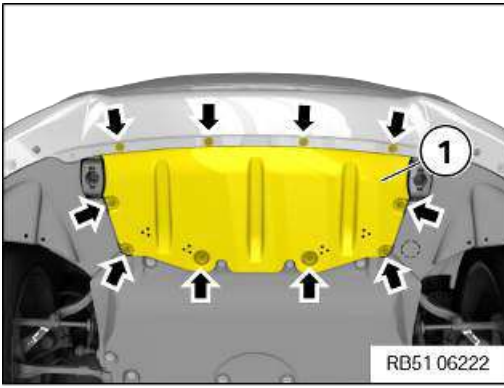

- **Version A:**

Remove screws (arrows).

Feed front underbody protection (1) backwards out of the bumper panel.

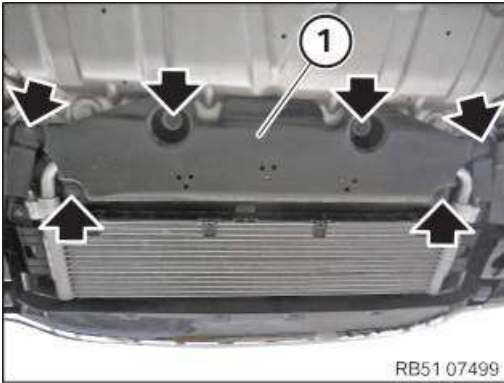

- **Version B:**

Remove screws (arrows).

Guide out front underbody protection (1) and remove it.

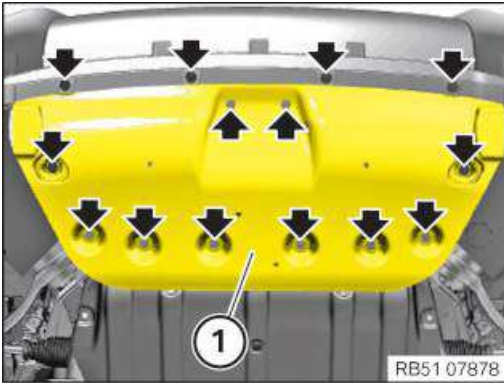

- **Version C:**

Remove screws (arrows).

Guide out front underbody protection (1) and remove it.

4 – Remove the underbody protection of the steering gear

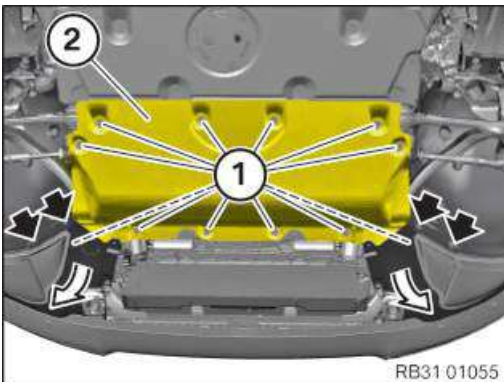

- **Version A:**

Unscrew the screws (arrows) of the wheel arch cover on the wheel arch cover.

Fold the bottom wheel arch cover to the side.

Loosen screws (1).

Remove the underbody protection (2) of the steering gear.

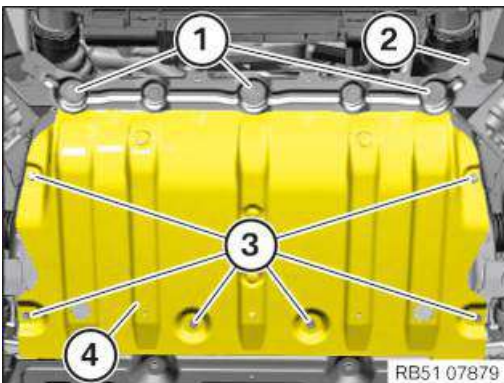

- **Version B:**

Loosen screws (1).

Remove the holder (2) for the underride protection.

Loosen screws (3).

Feed out and remove the underbody protection (4) of the steering gear.

5 – Removing the centre underbody protection



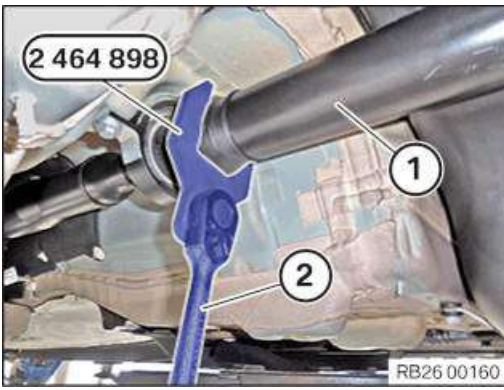

- **Version with a narrow universal joint:**

With the special tool [2 464 898](#) and a suitable tool (2), secure the propeller shaft (1) on the centre universal joint against twisting.

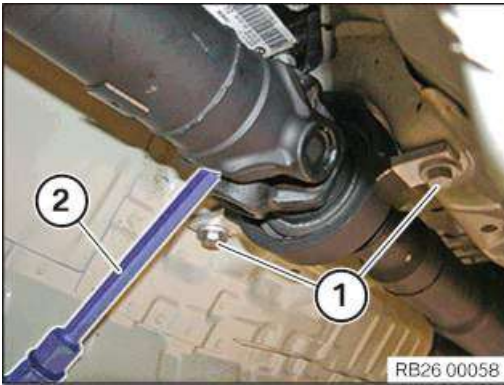

- **Vehicles with a broad universal joint:**

Secure the propeller shaft on the centre universal joint with a suitable tool (2) to protect it from twisting.

Remove the screws (1) of the centre mount only after opening the recessed nuts are removed completely.

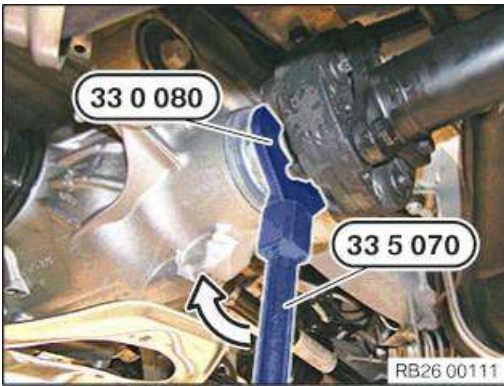

RISK OF DAMAGE

Damage to rear axle differential.

Non-observance of the removal and installation guidelines may cause severe damage to the rear axle differential.

- Do not use the double hexagon head flange nut as counter support.

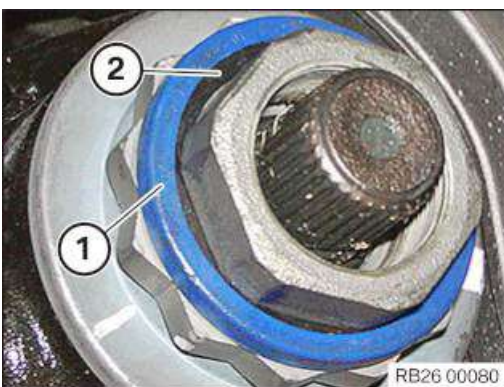

- Release the recessed nut with the special tools [0 495 554](#) ([33 5 070](#)) and **in the direction of arrow (clockwise).**

- Remove the mounting clip (1) and the seal (2).

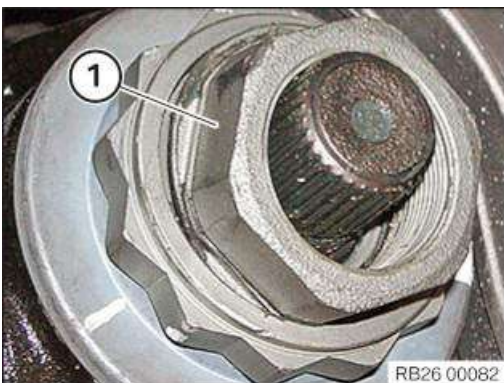

- Remove recessed nut (1).





NOTICE

The following work step(s) is / are to be carried out if the specified component(s) is/are fitted.

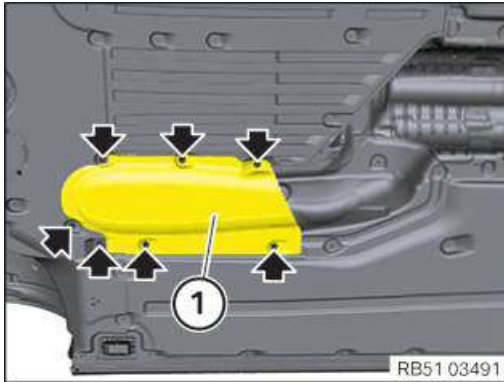

- Insert the underbody panelling (1).
- Tighten screws (arrows).

Underbody panelling

Screw	Tightening torque	2,6 Nm
Plastic nut	Tightening torque	2,6 Nm

21 – Replacement (rear axle differential or servomotor): Carrying out the "Delete wear data" service function



- Connect vehicle to the diagnosis system.
- Carry out the "Delete wear data" service function.

22 – Replacement (rear axle differential): carry out the service function for the correction values of the characteristic curve



- Connect vehicle to the diagnosis system.
- Carry out the "Correction values of the characteristic curve" service function.

Additional Information

Overview of Tightening Torques

Rear differential to rear axle carrier, front			Used in step 12
M12	Renew screw.	Tightening torque	100 Nm
Rear differential to rear axle carrier, rear			Used in step 12
M14	Renew nut.	Tightening torque.	175 Nm
Vibration absorber to rear axle			Used in step 13
M8	Renew screw.	Tightening torque	28 Nm
Vibration absorber to rear axle			Used in step 13
M10	Renew screw.	Jointing torque	56 Nm
		Angle of rotation	90 °
Rear axle differential oil filler plug			Used in step 15
M22	Renew the oil filler plug.	Tightening torque	60 Nm
Ground strap to rear axle differential			Used in step 16
M6x20		Tightening torque	8 Nm



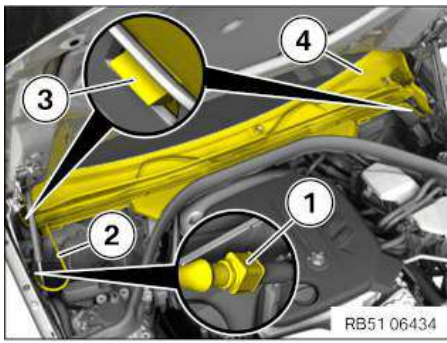

- Clip cowl panel cover (4) in by means of the latch mechanisms (3).
- Position windscreen wash hose (2) and connect windscreen wash hose (1) quick lock.

14 – Install left and right wiper arm



NOTICE

Description is for left component only. Procedure on the right side is identical.

► Installing left and right wiper arm



TECHNICAL INFORMATION

The wiper system must be in zero position.

After installing the cowl panel cover and before fitting the wiper arm:

Activate the wiper system once to ensure that it has the correct installation position.

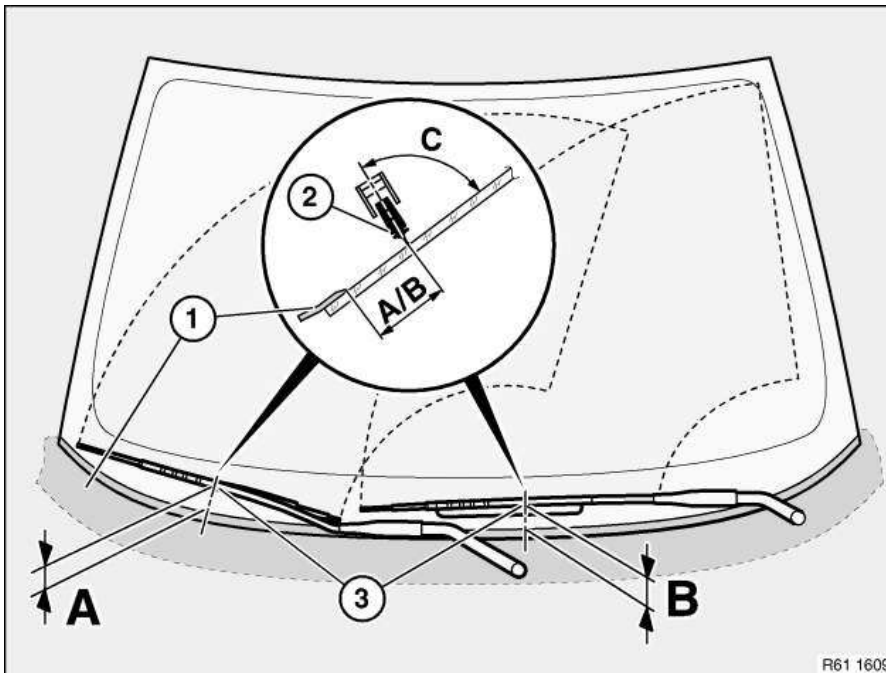

- Connect the wiper arm (3).
- Correctly position the wiper arm (2) in relation to the window edge (1).

Distance from window pane edge to wiper blade

Wiper arm right (A)	$57,5 \pm 5 \text{ mm}$
Wiper arm left (B)	$63,3 \pm 4 \text{ mm}$

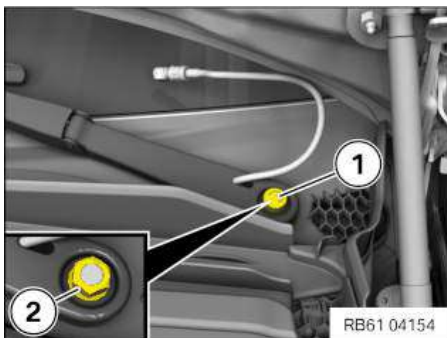

- Tighten nut (2).

Windscreen wiper arm

Combination hexagon nut	Tightening torque	35 Nm
-------------------------	-------------------	-------

- Connect the protective cap (1).



After replacing the airbag unit (M sport steering wheel) or after a possible conversion of standard steering wheel and airbag unit to M-sports steering wheel, a software update or a programming/encoding via ISTA must be performed!

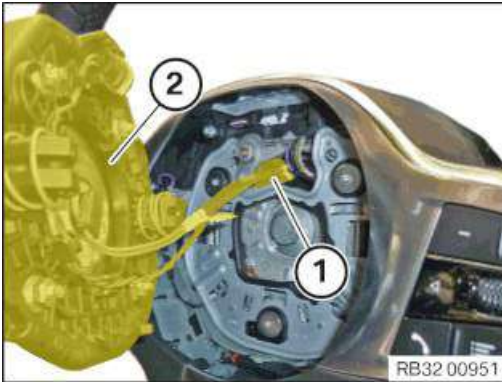

- Connect and lock the connector (1) of the airbag unit (2).



- Press the airbag unit further (1) with even pressure in the direction of the arrow into the steering wheel.

The airbag unit (1) must engage audibly and perceptibly.

57 – Install the central information display (CID)



RISK OF DAMAGE



Electrostatic discharge.

Damage to or destruction of electrical components.

- Leave electrical components in original packaging until just before they are installed. Use the original packaging only for any return shipments. Always package removed components straight away.
- Read and comply with user information on using the associated special tool 12 7 060.
- Only touch the housings of electrical components. Do not touch pins or multi-pin connectors directly.
- Wear electrically conductive clothing and antistatic shoes (with ESD symbol).
- For additional information see: 61 35 ... Notes for ESD protection (electrostatic discharge)

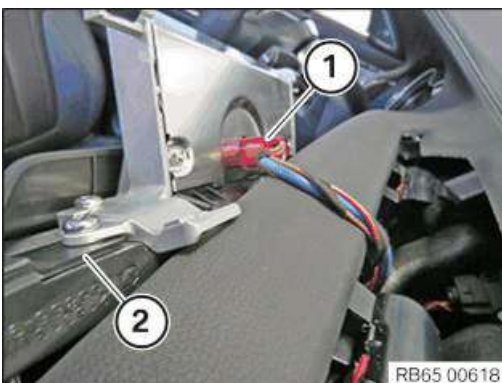

- Position Central Information Display (CID) (2).
- Connect plug connection (1) and lock.





WARNING

Airbag unit.

Danger! Life-threatening injuries!

- Before performing any work on the airbag, always disconnect the battery earth lead from the battery.
- Airbag unit may only be set down with the cushion (airbag itself) facing upwards.
- For additional information see: 72 00 ... Safety regulations on handling airbag system components/gas generators



WARNING

Pyrotechnic components.

Danger! Life-threatening injuries!

- All work on pyrotechnic parts may be carried out by technically experienced and appropriately trained personnel only.
- Replace any damaged part or ones that have been dropped.
- For additional information see: 72 00 Safety regulations on handling components with gas generators.



- Detach the backrest cover (1) in this area (2).
- Unhook seat cover (3).



- Unclip clips (1).
- Unlock plug connection (2) and disconnect.

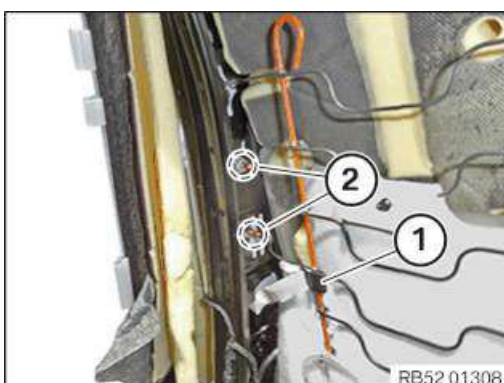

- Detach the holder (1).
- Loosen nuts (2).



61 31 118 Removing and installing/replacing power window switch on passenger's side

PRELIMINARY WORK

1 – Remove front door trim panel



RISK OF DAMAGE

Damage of high-quality surfaces.

Plastic wedges can damage high-quality surfaces.

- Protect surfaces from damage.

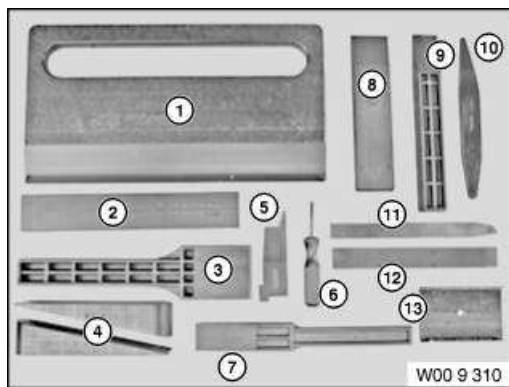

- Have the set of special tools [0 493 752 \(00 9 329\)](#) ready.

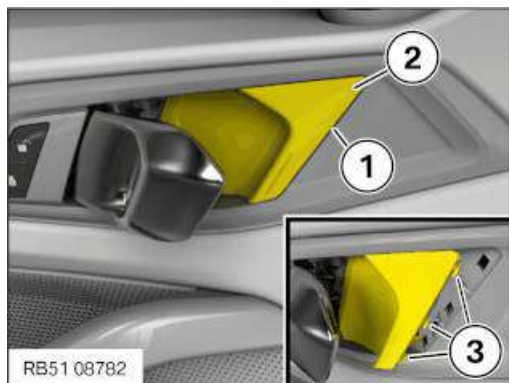

- Pull the door handle.
- Position suitable special tool on the recess in the area (1).
- Unclip the cover of the door handle (2) with the latch mechanisms (3).
- Feed out the cover of the door handle (2) from the latch mechanisms and remove it forwards.

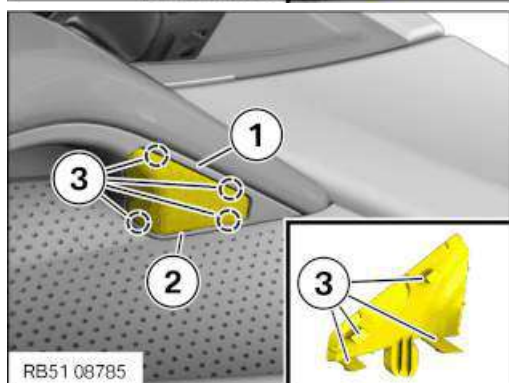

- Position suitable special tool on the recess in the area (1).
- Unclip the cover (2) with the latch mechanisms (3) and remove it downwards.



64 51 591 Removing and installing/renewing evaporator



CAUTION

Refrigerant circuit under high pressure.

Danger of injury!

- Note and follow safety information on containers.
- Avoid contact with refrigerant; wear safety goggles and protective gloves.
- For additional information see: 64 50 Handling refrigerant and 6450 Notes on air conditioning repair work

PRELIMINARY WORK

1 – Drawing off the air conditioning

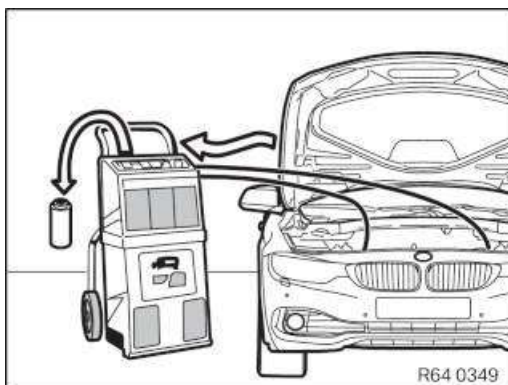

- See additional information.

2 – Removing the acoustic cover



RISK OF DAMAGE

Damage to the acoustic cover/design cover.

Jerky movements during disassembly and excessive application of force during installation may result in breakage of the acoustic cover/design cover.

- Disassemble or mount the acoustic cover/design cover carefully.
- Disassemble or mount snap-lock couplings of the ball pivots one after the other.
- Disassemble or mount acoustic cover/design cover only at temperatures $>20\text{ }^{\circ}\text{C}$.
- Use only distilled water as an auxiliary material during installation, no lubricants.



- Unclip the acoustic cover (1) from the holders in the indicated area towards the top.

3 – Detach the control unit holder



00 Safety information for working on vehicles with automatic engine start-stop function (MSA)



Warning!

If the engine hood/bonnet contact is pulled upwards (workshop mode), the information "switch closed" is output. The automatic engine start-stop function is active.

An automatic engine start is possible.

Observe safety precautions when working on MSA vehicles.

Before carrying out practical work on the engine, always ensure that the MSA functionality is deactivated so as to prevent automatic engine starting while work is being carried out in the engine compartment.

MSA function is deactivated by:

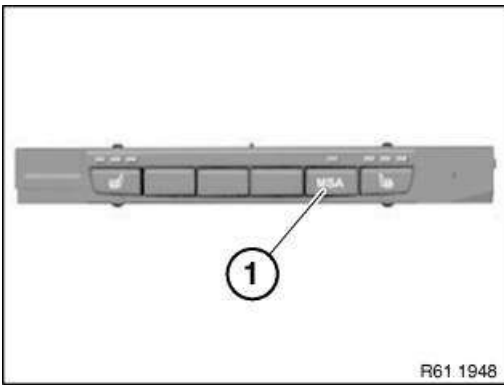

- Deactivate MSA by means of button (1) in passenger compartment
- Open seat belt buckle and driver's door

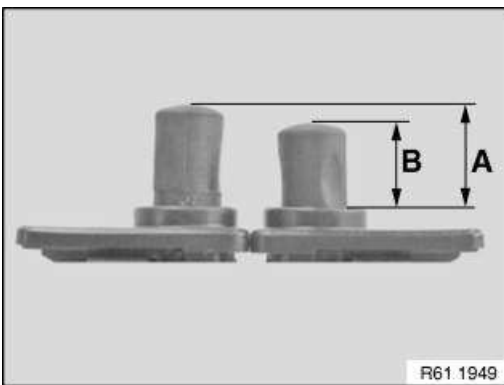

- Open engine bonnet/hood and ensure that engine hood/bonnet contact is not in workshop mode
 - Workshop mode
A = 10 mm
 - Basic setting (engine hood/bonnet open)
B = 7 mm

To make sure that the engine hood/bonnet contact is at the basic setting, if necessary press the hood/bonnet contact up to the limit position before starting work and slowly release.



When working with diagnosis tools:

- Observe instructions in diagnosis tool

