



1 General information

(AIGG001031; Edition 10.2019)

Change history ⇒ [page 1](#)

Engine number ⇒ [page 1](#)

Vehicle identification number ⇒ [page 2](#)

Vehicle data sticker ⇒ [page 3](#)

Warnings for high-voltage vehicles ⇒ [page 3](#)

1.1 --- Change history ---

No.	Date	Chapter	Changes made
5	25.10.2019	Seal on coolant expansion tank for high-voltage system: checking seal is present ⇒ page 90	New chapter
4	07.10.2019	SCR system: checking ⇒ page 25	New chapter
3	06.06.2019	Emergency call function: checking status LED ⇒ page 21	New chapter



Note

For greater clarity, only the last three updates to the document are listed.

1.2 Engine number



Note

The engine number consists of the engine code letters (3 or 4 characters) and the serial number.

4-cyl. petrol engine 2.0 TFSI ⇒ [page 1](#)

6-cyl. petrol engine 3.0 TFSI ⇒ [page 2](#)

4-cyl. diesel engine 2.0 TDI ⇒ [page 2](#)

6-cyl. diesel engine 3.0 TDI ⇒ [page 2](#)

1.2.1 4-cyl. petrol engine 2.0 TFSI

The engine number is stamped on the left side at the joint between the engine and the gearbox -arrow-.

The engine number is also given on the sticker on the timing chain cover (top).

In addition, the engine code letters are listed on the vehicle data sticker ⇒ [page 3](#).

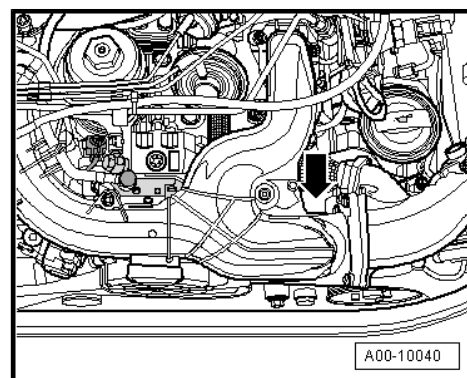



- Unscrew pressure control valve -2- completely and close valves -3- and -4-.
- Make sure knob is pulled out before turning pressure control valve -2-.
- Using a commercially available connection piece, connect charge air system tester - V.A.G 1687- to compressed air -1-.
- If there is water in sight glass, remove drain plug -6- and drain water.
- Open valve -3-.



Caution

Risk of damage if pressure is set too high.

- ◆ *The pressure must not exceed 0.2 bar.*

- Adjust pressure to 0.2 bar via pressure control valve -2-.
- Open valve -4- and wait until test system is pressurised. If necessary, adjust pressure to 0.2 bar again.
- Check charge air system for audible leaks or leaks that can be felt with the hand; apply commercially available leak detecting spray or use ultrasonic tester - V.A.G 1842- .



Note

- ◆ *A small amount of air escapes through the valves and enters the engine. Therefore it is not possible to perform a pressure retention test.*
- ◆ *Operation of ultrasonic tester - V.A.G 1842- ⇒ Operating instructions .*
- ◆ *Release pressure in test circuit by detaching coupling from adapter before removing adapter.*
- ◆ *Secure all hose connections with correct type of hose clips (as original equipment) ⇒ Electronic parts catalogue .*

Assembling

Assemble in reverse order.

Additional work depending on model ⇒ 4-cylinder direct injection engine (2.0 ltr. 4-valve TFSI); Rep. gr. 21 ; Charge air system; Checking charge air system for leaks

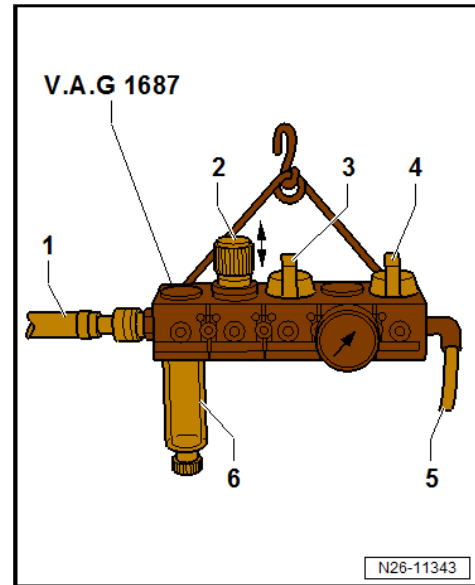



2.14 Adapting rear sliding sunroof control unit - J392-

If rear sliding sunroof control unit - J392- is renewed, it must be activated after installation.

- Connect vehicle diagnostic tester .
- Switch on ignition.
- Select and start **Diagnosis** mode.
- Select **Test plan** tab.
- Choose **Select own test** and select following options one after the other:
 - ◆ Systems with diagnostic capability
 - ◆ 00DD - Sun roof control unit 2 -J392
 - ◆ 00DD - Sun roof control unit 2, functions
 - ◆ 00DD - Rear sunroof sun blind - J867 - no basic setting
- Start selected program and follow instructions on display of vehicle diagnostic tester.

2.15 Removing and installing sliding sunroof motor - V1-

⇒ ["2.15.1 Removing and installing sliding sunroof motor V1 - A6", page 300](#)

⇒ ["2.15.2 Removing and installing sliding sunroof motor V1 - A7 Sportback", page 300](#)

2.15.1 Removing and installing sliding sunroof motor - V1- - A6

- The following components have to be renewed after removal ⇒ [page 219](#) .

Removing

- Detach moulded headliner and place on seats ⇒ General body repairs, interior; Rep. gr. 70 ; Roof trim panels; Removing and installing moulded headliner .
- Unscrew bolts -arrows- and remove sliding sunroof motor -2-.
- Release and unplug electrical connector -1-.

Installing

Installation is carried out in reverse order; note the following:

- Remove any remaining locking fluid from threaded holes with suitable thread tap.
- Perform adaption ⇒ [page 301](#) .

Tightening torques

- ◆ ⇒ ["2.1 Exploded view - sliding sunroof", page 219](#)

2.15.2 Removing and installing sliding sunroof motor - V1- - A7 Sportback

- The following components have to be renewed after removal ⇒ [page 223](#) .

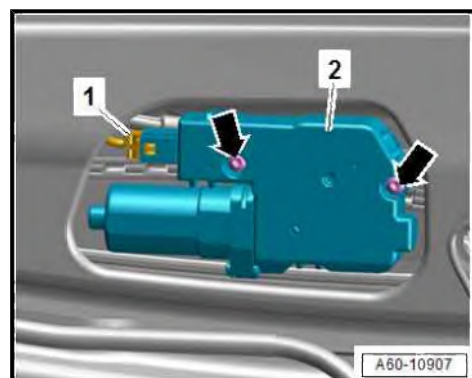



3 Door trim (rear)

⇒ [“3.1 Exploded view - door trim \(rear\)”, page 182](#)

⇒ [“3.2 Exploded view - sun blind for door window”, page 184](#)

⇒ [“3.3 Removing and installing loudspeaker trim in door trim”, page 184](#)

⇒ [“3.4 Removing and installing trim panel”, page 185](#)

⇒ [“3.5 Removing and installing door trim \(rear\)”, page 186](#)

⇒ [“3.6 Removing and installing door puller \(rear\)”, page 187](#)

⇒ [“3.7 Removing and installing interior door handle”, page 189](#)

⇒ [“3.8 Removing and installing window frame trim”, page 189](#)

⇒ [“3.9 Removing and installing sun blind for door window”, page 190](#)

⇒ [“3.10 Removing and installing retainer for sun blind”, page 191](#)

3.1 Exploded view - door trim (rear)

1 - Lining for door pocket

- Insert into door

2 - Switch mounting

- Removing and installing
⇒ [“3.6 Removing and installing door puller \(rear\)”, page 187](#)

3 - Bolt

- 3x
- 2.5 Nm

4 - Door trim

- For correct version, refer to ⇒ Electronic parts catalogue
- Removing and installing
⇒ [page 186](#)

5 - Clip

- 7x or 8x
- Insert in trim

6 - Bolt

- 11x or 12x
- 1.2 Nm

7 - Bolt

- 4x
- 1.2 Nm

8 - Window frame trim

- Removing and installing
⇒ [page 189](#)

9 - Insulating mat

10 - Bolt

- 7x or 9x

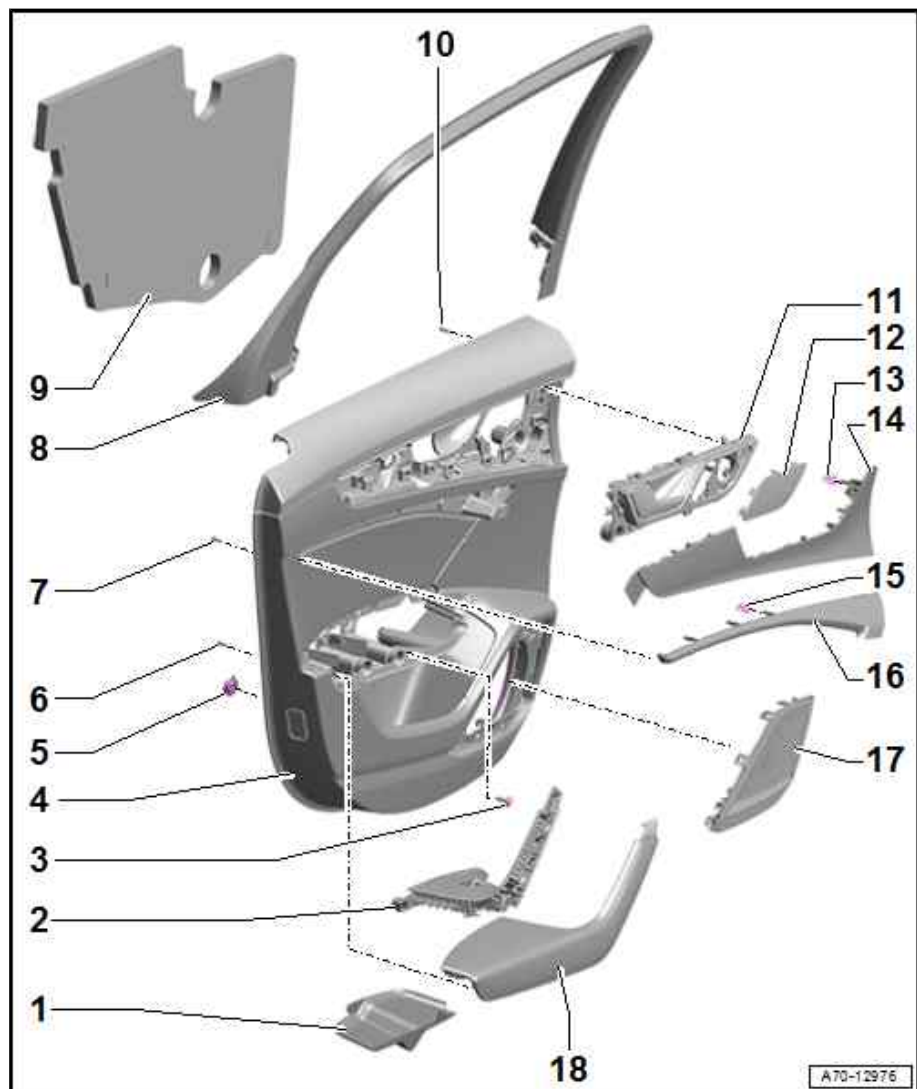

Slot	Current flow diagram designation	Nominal value	Function / component	Terminal
2	not assigned	-	-	-

Back to overview ⇒ [page 1](#) .

1.14 Single fuses, relay and fuse carrier 2 -SR2-

- ◆ ⇒ ["1.14.1 Fitting location for single fuses relay and fuse carrier 2 SR2 , LHD", page 54](#)
- ◆ ⇒ ["1.14.2 Fitting location for single fuses relay and fuse carrier 2 SR2 , RHD", page 56](#)
- ◆ ⇒ ["1.14.3 Fuse assignment for single fuses relay and fuse carrier 2 SR2 , LHD", page 57](#)
- ◆ ⇒ ["1.14.4 Fuse assignment for single fuses relay and fuse carrier 2 SR2 , RHD", page 57](#)

1.14.1 Fitting location for single fuses relay and fuse carrier 2 -SR2- , LHD

Back to overview ⇒ [page 1](#)

1.5.2 Rear side, view from right, Avant

A - 17-pin connector -T17u- , black / 17-pin connector -T17ux- , black

1 - Towing bracket release button -E754-

2 - Digital sound package control unit -J525-

3 - Window aerial suppression filter -C18-

- Fitting location for Avant
- Fitting location for saloon ⇒ -Fitting locations: middle part of vehicle

4 - Left effect loudspeaker -R209-

- Fitting location for Avant
- Fitting location for saloon ⇒ -Fitting locations: middle part of vehicle

5 - Control unit for rear left belt tensioner -J1097-

- Fitting location for Avant
- Fitting location for saloon ⇒ -Fitting locations: middle part of vehicle

6 - Left boot light -W18-

7 - Tank filler flap locking motor -V155-

8 - Rear right park assist steering sender -G717-

9 - Emergency call module aerial -R263-

10 - Lane change assist control unit -J769-

11 - Right tail light -MX4-

12 - Subwoofer -R211-

- for vehicles with Standard Sound (9VD)/Premium Sound (9VS) and with alternative drive system (0K4)
- Fitting location for models with Advanced Sound (8RF) ⇒ [Item 10 \(page 19\)](#)
- for vehicles with Standard Sound (9VD)/Premium Sound (9VS) and without alternative drive system (0K0) ⇒ [Item 4 \(page 20\)](#)

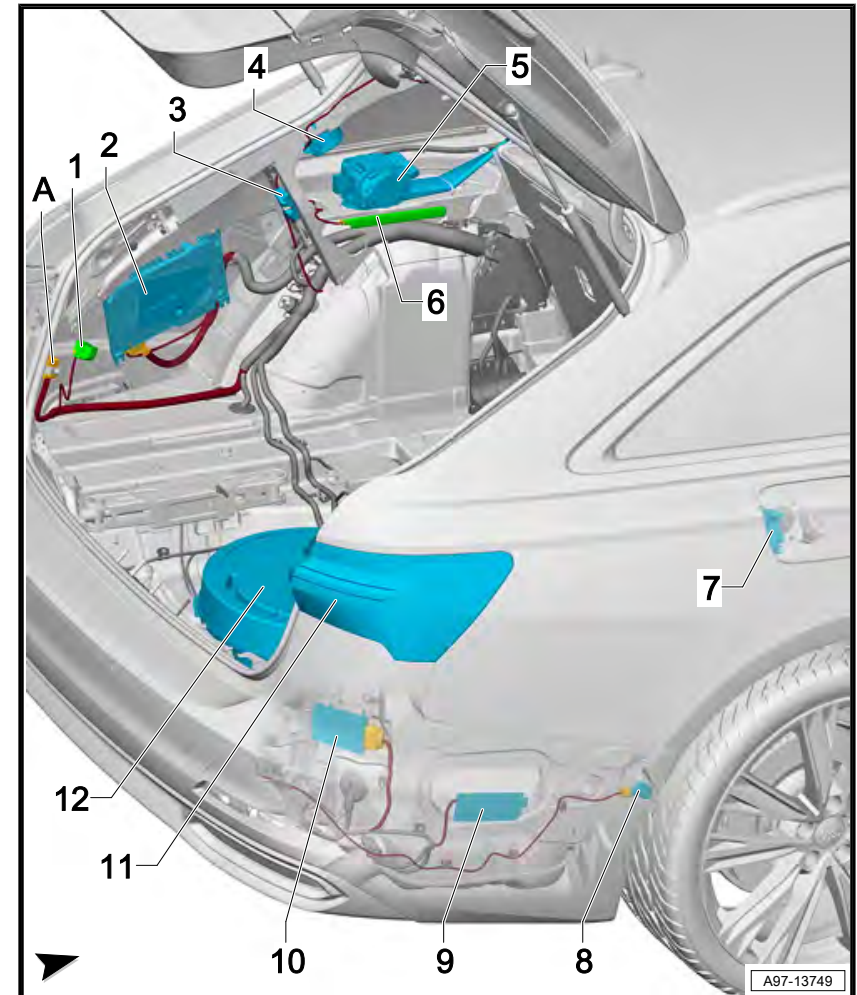

1.52.2 Connector -T6bo-

Connector -T6bo-

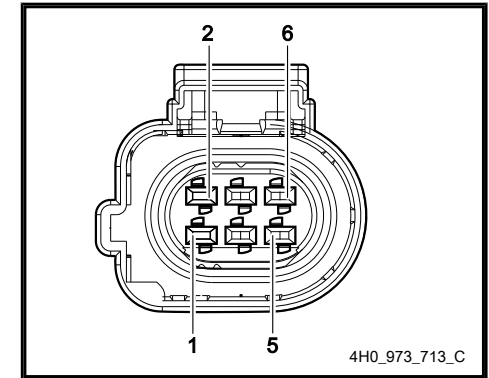

1.52.3 Connector -T6bp-

Connector -T6bp-

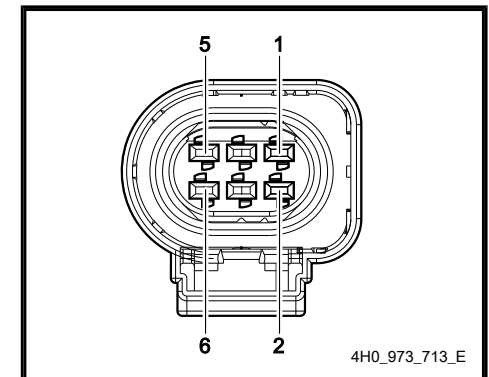

1.52.4 Connector -T6br-

Connector -T6br-

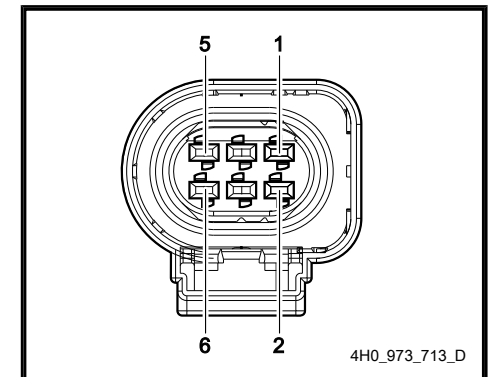



- ❑ Exploded view ⇒ [“2.2 Exploded view - condenser”, page 38](#)

11 - Connection of refrigerant line (low-pressure side)

- ❑ Fitted in area around headlight (left-side) underneath wing

12 - Refrigerant line with internal heat exchanger

- ❑ Fitted in area underneath wing (left-side)
- ❑ In this refrigerant line, the hot liquid refrigerant flowing through the high-pressure side gives off energy to the cold refrigerant vapour flowing through the low-pressure side, thus enhancing the efficiency of the air conditioner

13 - Connection of refrigerant line (high-pressure side)

- ❑ Fitted in area around headlight (left-side) underneath wing

Air conditioner (internal heat exchanger, expansion valve, evaporator, service connections)

HD = High-pressure side

ND = Low-pressure side

1 - Refrigerant line with internal heat exchanger

- ❑ Fitted in area underneath wing (left-side)
- ❑ In this refrigerant line, the hot liquid refrigerant flowing through the high-pressure side gives off energy to the cold refrigerant vapour flowing through the low-pressure side, thus enhancing the efficiency of the air conditioner

2 - Leadthrough for refrigerant lines

- ❑ From area underneath wing (left-side) into plenum chamber
- ❑ Version without outputs to second evaporator

3 - Service connection (high-pressure side)

- ❑ For measuring, discharging and charging
- ❑ Depending on vehicle version, installed in plenum chamber (left-side, next to brake fluid reservoir) underneath plenum chamber cover
- ❑ Different versions depending on refrigerant (R134a or R1234yf) ⇒ Electronic parts catalogue

4 - Cap

- ❑ With seal
- ❑ Always screw on
- ❑ Different versions depending on refrigerant (R134a or R1234yf) ⇒ Electronic parts catalogue

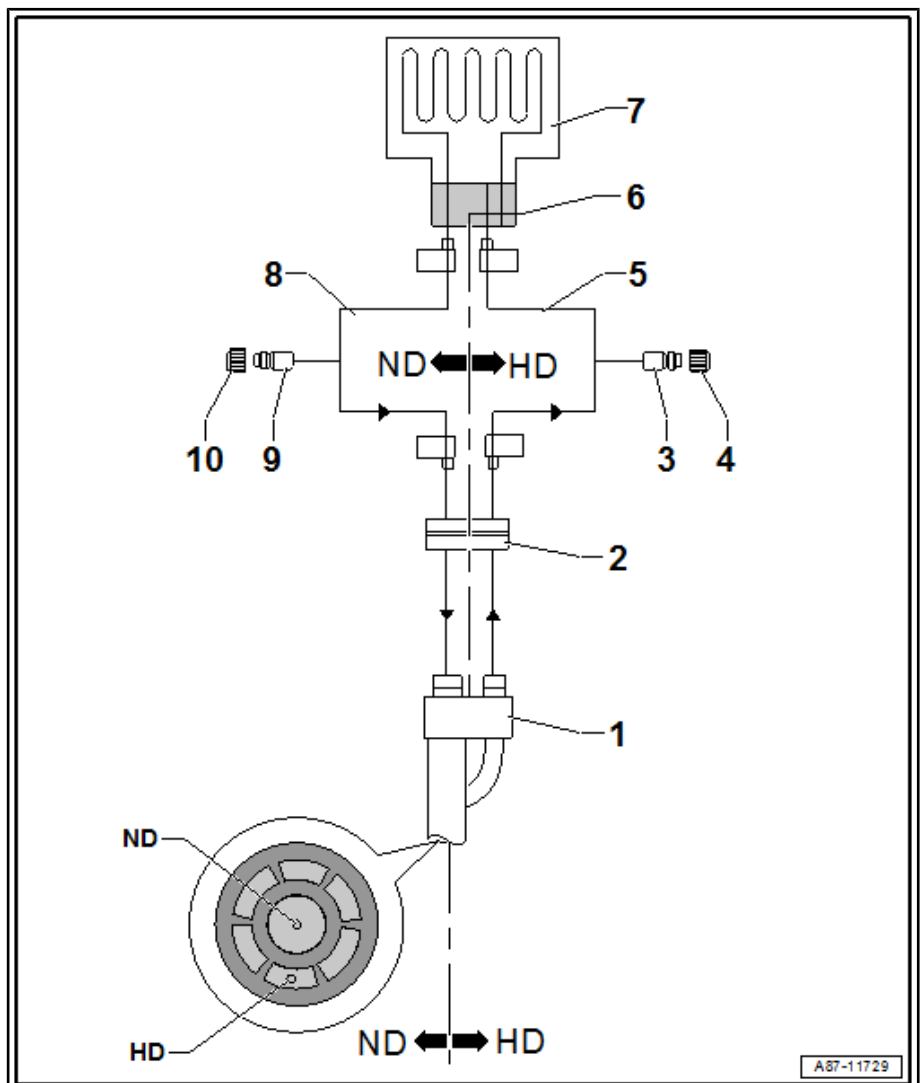



◆ Output module for right matrix headlight - A45-

- Removing and installing ⇒ [page 170](#)

17 - Bolt

- 5x
- 1.5 Nm

18 - Housing cover

19 - Sealing frame

- Removing and installing ⇒ [page 145](#)

20 - Adjuster element

- To adjust headlight housing to bumper contour

21 - Bolt

- 4.5 Nm

22 - Bolt

- 1.5 Nm

23 - Headlight fan 2

- For headlight version with laser main beam

◆ Left headlight fan 2 - V463-

◆ Right headlight fan 2 - V464-

- Removing and installing ⇒ [page 173](#)

24 - Bracket

- For headlight fan 2

25 - Bolt

- 1.5 Nm

26 - Housing cover

27 - Bolt

- 3x
- 1.5 Nm

28 - Filter membrane

- Removing and installing ⇒ [page 145](#)



2.1.6 Exploded view - repair kit for headlight, A6

1 - Headlight housing

2 - Inner bracket

- ❑ From headlight housing repair kit ⇒ Electronic parts catalogue
- ❑ Renewing ⇒ [page 180](#)

3 - Bolt

- ❑ 3x
- ❑ 6 Nm

4 - Adjuster nut

- ❑ For adjusting height of headlight

5 - Bolt

- ❑ 2x
- ❑ 6 Nm

6 - Centre bracket

- ❑ From headlight housing repair kit ⇒ Electronic parts catalogue
- ❑ Renewing ⇒ [page 180](#)

7 - Outer bracket

- ❑ From headlight housing repair kit ⇒ Electronic parts catalogue
- ❑ Renewing ⇒ [page 180](#)

8 - Bolt

- ❑ 2x
- ❑ 6 Nm

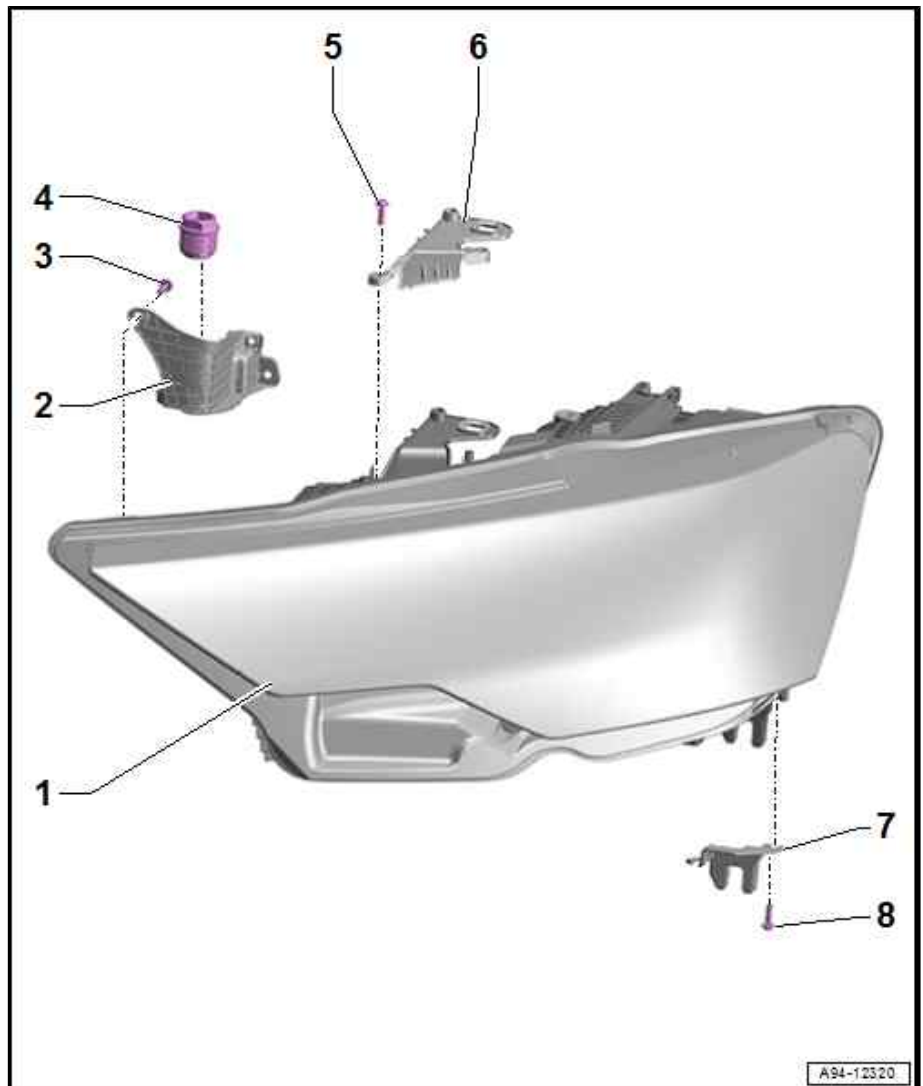



- On appropriate version: Unplug electrical connector -1-.
- Remove bolts -arrows- securing shock absorber at top.

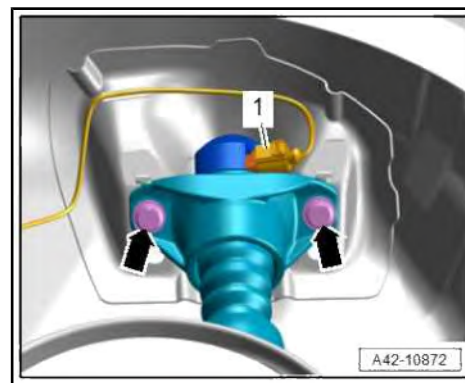

- Remove bolt -1- and detach shock absorber -2-.

Installing

Installation is carried out in reverse order; note the following:

- Screw in bolts initially until they make contact, but do not tighten to final torque yet.
- Bonded rubber bushes can only be turned to a limited extent. The suspension mountings must therefore only be tightened when the suspension is in the unladen position.
- Lifting suspension to unladen position ⇒ [page 9](#)
- Overview table: when does wheel alignment have to be checked? ⇒ [page 238](#)

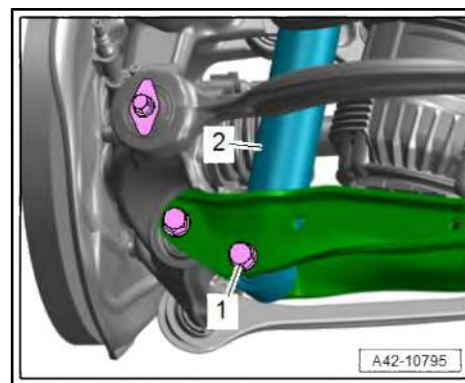

Tightening torques

- ◆ ⇒ [“5.1.3 Exploded view - shock absorber”, page 163](#)
- ◆ ⇒ General body repairs, exterior; Rep. gr. 66 ; Wheel housing liners; Exploded view - wheel housing liner (rear)
- ◆ ⇒ [“1 Wheels, tyres”, page 234](#)

5.3 Removing and installing spring

⇒ [“5.3.1 Removing and installing coil spring”, page 167](#)

⇒ [“5.3.2 Removing and installing air spring”, page 174](#)

5.3.1 Removing and installing coil spring

Special tools and workshop equipment required

- ◆ Foot pump - VAS 6179-

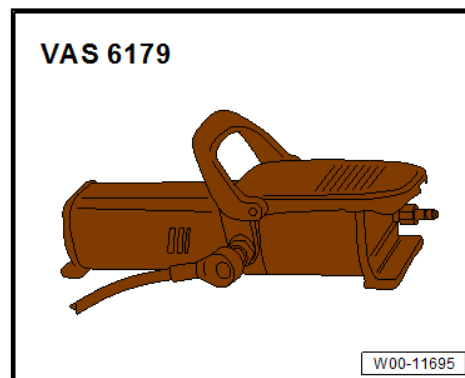



5.1.2 Exploded view - starter-alternator - C29- , vehicles with 4-cylinder TFSI engine (OK4 + VH0)

1 - Bolt

- Not available as replacement part

2 - Idler roller

- Not available as replacement part

3 - Bolt

- Not available as replacement part

4 - Idler roller

- Not available as replacement part

5 - Bolt

- Tightening torque ⇒ Engine; Rep. gr. 13 ; Cylinder block (pulley end); Exploded view - cylinder block (pulley end)

6 - Starter-alternator - C29-

- Removing and installing ⇒ [page 66](#)

7 - Electrical connector

8 - Terminal 30/B+

9 - Nut

- 20 Nm

10 - Bolt

- 4x
- Aluminium bolt
- Renew after removing
- 8 Nm +180°

11 - Tensioner

- For starter-alternator - C29-
- Removing and installing ⇒ Engine; Rep. gr. 13 ; Cylinder block (pulley end); Removing and installing tensioner for poly V-belt

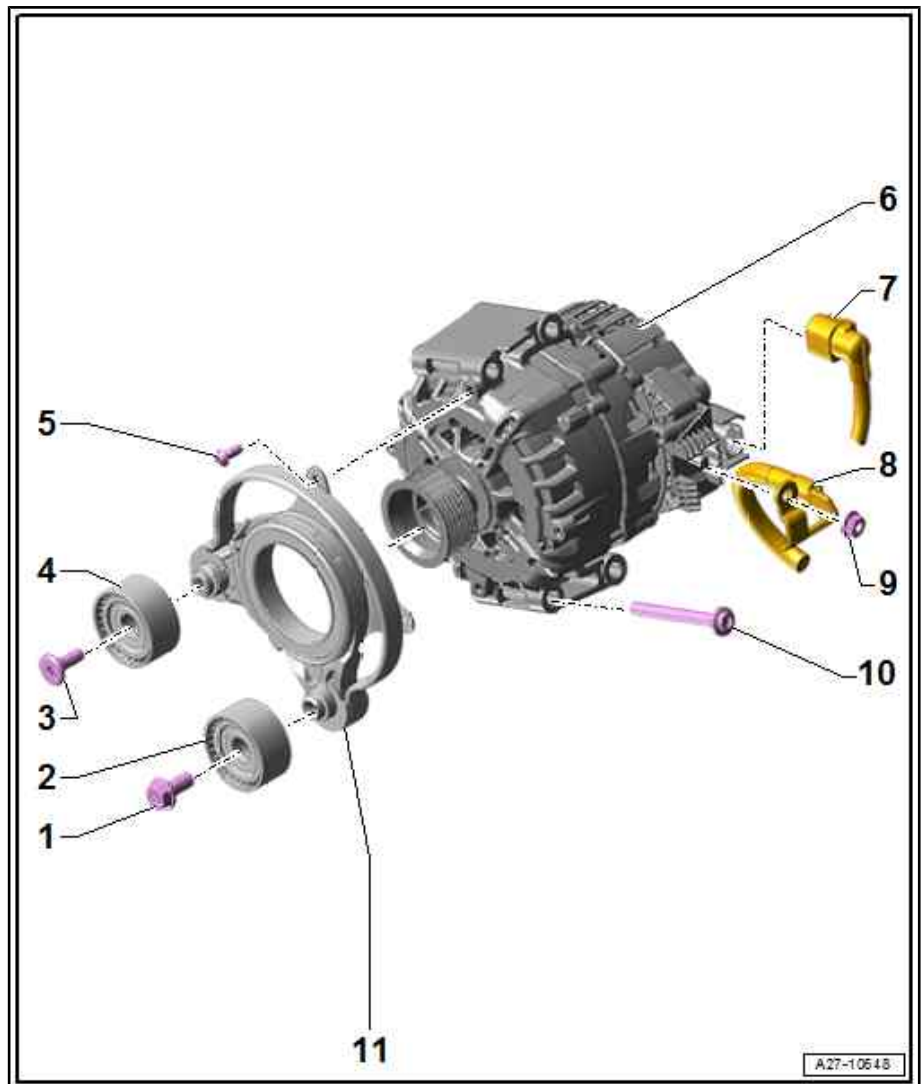

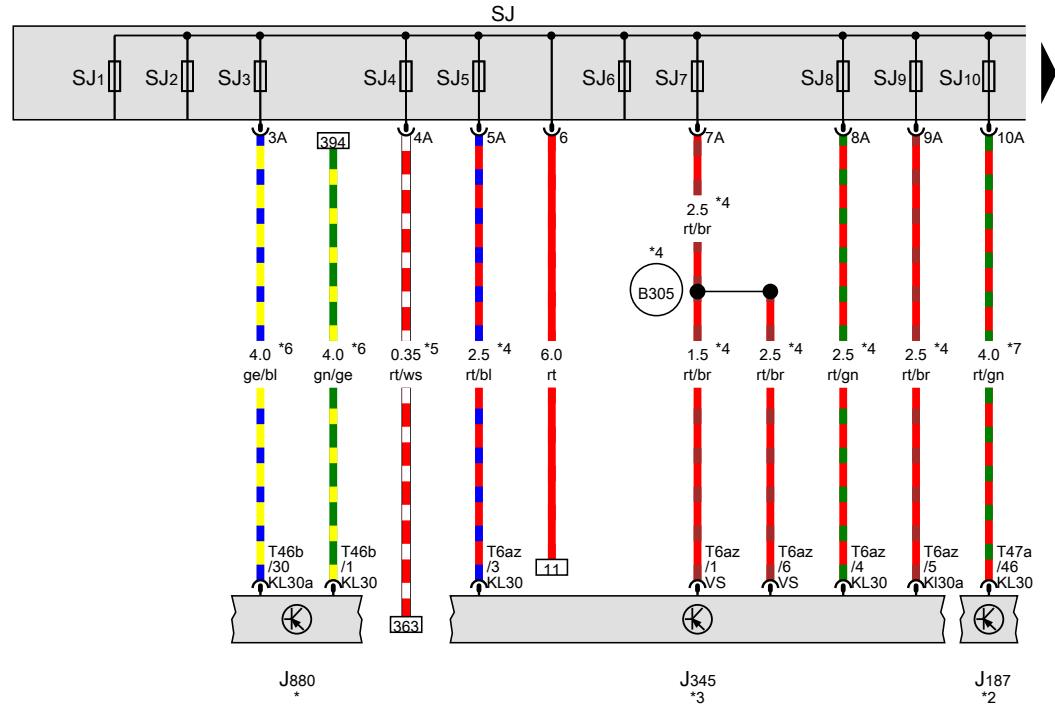

Fuse holder J

- J187 Differential lock control unit
- J345 Trailer detector control unit
- J880 Control unit for reducing agent metering system
- SJ Fuse holder J
- SJ1 Fuse 1 on fuse holder J
- SJ2 Fuse 2 on fuse holder J
- SJ3 Fuse 3 on fuse holder J
- SJ4 Fuse 4 on fuse holder J
- SJ5 Fuse 5 on fuse holder J
- SJ6 Fuse 6 on fuse holder J
- SJ7 Fuse 7 on fuse holder J
- SJ8 Fuse 8 on fuse holder J
- SJ9 Fuse 9 on fuse holder J
- SJ10 Fuse 10 on fuse holder J
- T6az 6-pin connector, black
- T46b 46-pin connector, black
- T47a 47-pin connector, black

B305 Positive connection 9 (30), in main wiring harness

- * see applicable current flow diagram for engine
- *2 see applicable current flow diagram for all-wheel drive
- *3 see applicable current flow diagram for towing bracket
- *4 For models with towing bracket
- *5 According to equipment
- *6 For models with reducing agent metering system
- *7 For models with all-wheel drive

- ws = white
- sw = black
- ro = red
- rt = red
- br = brown
- gn = green
- bl = blue
- gr = grey
- li = purple
- vi = purple
- ge = yellow
- or = orange
- rs = pink

Seat and steering column adjustment control unit with memory, Left footwell light

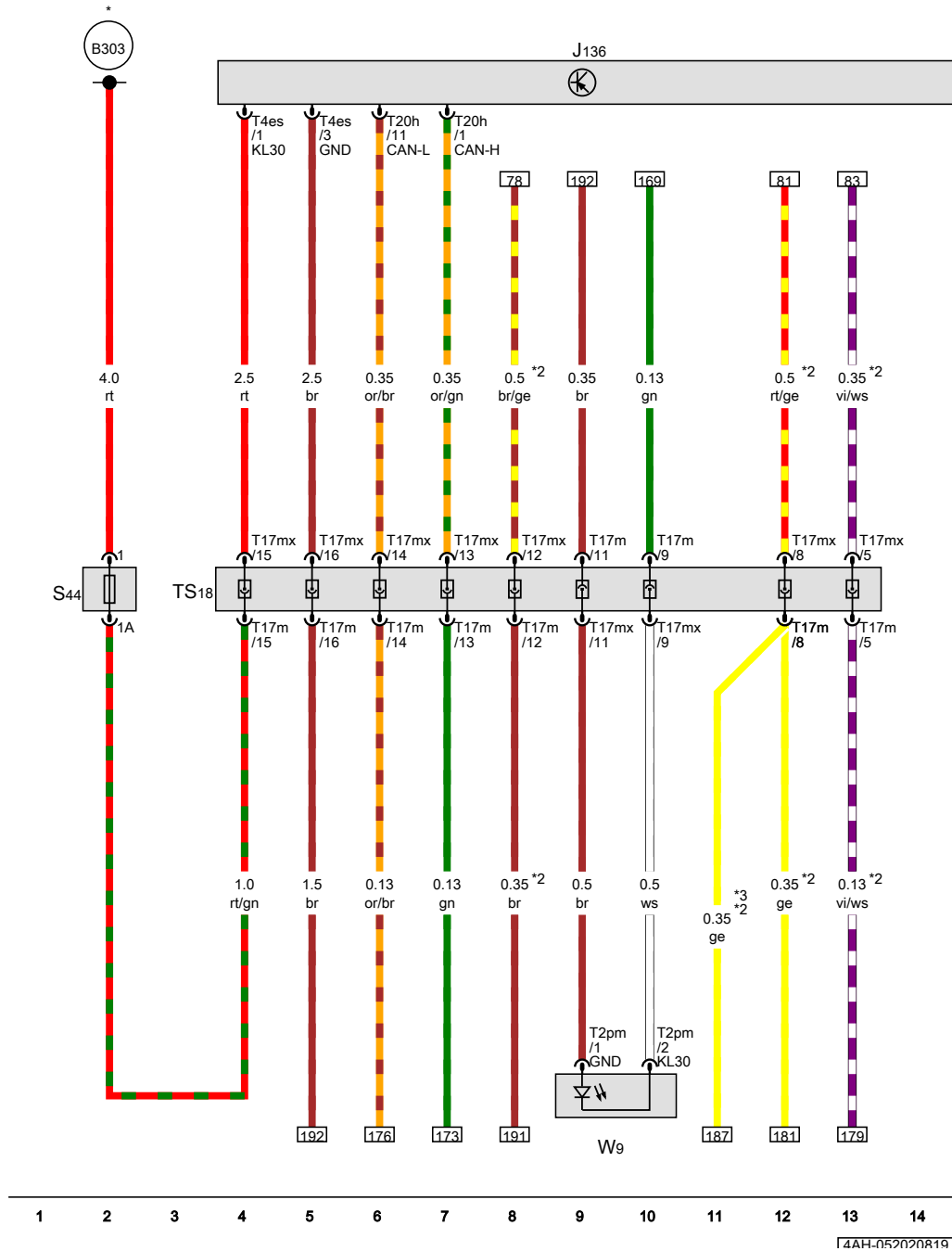

- J136 Seat and steering column adjustment control unit with memory
- S44 Driver seat adjustment thermal fuse 1
- T2pm 2-pin connector, brown
- T4es 4-pin connector, black
- T17m 17-pin connector, red
- T17mx 17-pin connector, red
- T20h 20-pin connector, black
- TS18 Coupling point for seat, driver side
- W9 Left footwell light
- B303** Positive connection 7 (30), in main wiring harness

- * see applicable current flow diagram for fuse assignment
- *2 For models with seat ventilation
- *3 For models with hybrid drive system

- ws = white
- sw = black
- ro = red
- rt = red
- br = brown
- gn = green
- bl = blue
- gr = grey
- li = purple
- vi = purple
- ge = yellow
- or = orange
- rs = pink

[4AH-052020R19]

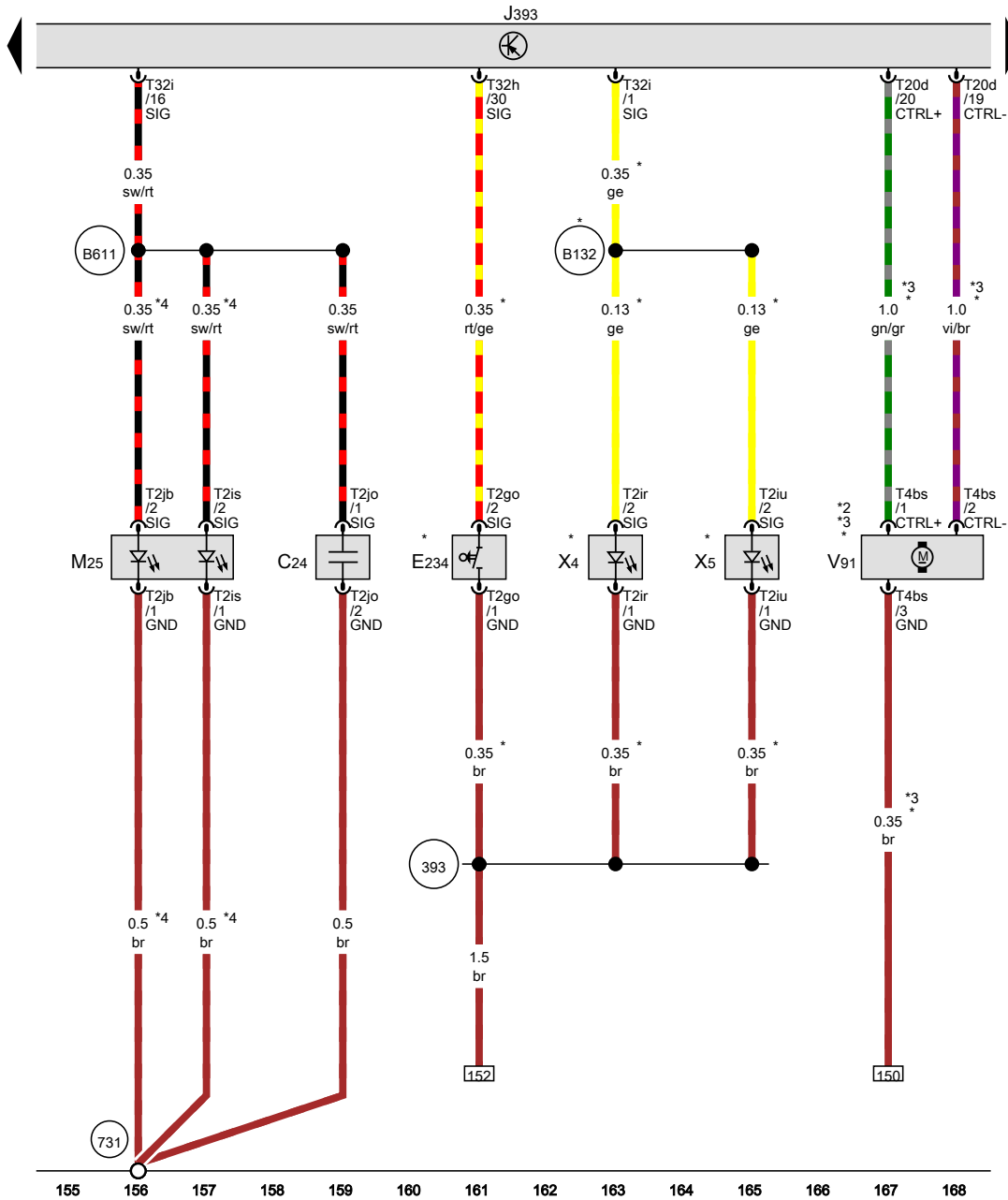

Rear lid handle release button, Convenience system central control unit, High-level brake light bulb, Rear roller blind motor, Left number plate light, Right number plate light

- C24 Suppression filter
- E234 Rear lid handle release button
- J393 Convenience system central control unit
- M25 High-level brake light bulb
- T2go 2-pin connector, black
- T2ir 2-pin connector, black
- T2is 2-pin connector, red
- T2iu 2-pin connector, black
- T2jb 2-pin connector, green
- T2jo 2-pin connector
- T4bs 4-pin connector, black
- T20d 20-pin connector, black
- T32h 32-pin connector, blue
- T32i 32-pin connector, colourless, black
- V91 Rear roller blind motor
- X4 Left number plate light
- X5 Right number plate light

- 393 Earth connection 28, in main wiring harness
- 731 Earth point 2, on right rear wheel housing
- B132 Connection (number plate lights), in interior wiring harness
- B611 Connection 7, in interior wiring harness

- * Saloon
- *2 Pre-wired component
- *3 For models with electric rear roller blind
- *4 According to equipment

- ws = white
- sw = black
- ro = red
- rt = red
- br = brown
- gn = green
- bl = blue
- gr = grey
- li = purple
- vi = purple
- ge = yellow
- or = orange
- rs = pink

14AH-097130R191