

ACURA
G4
LEGEND 1987

INDEX

<i>GENERAL INFORMATION</i>	4
<i>DIAGNOSIS</i>	14
<i>PRESSURE CHECKS</i>	17
<i>COMPONENT DISASSEMBLY</i>	21
<i>TEARDOWN</i>	34
<i>VALVE BODY</i>	35
<i>ASSEMBLY</i>	45
<i>CLUTCH PACKS</i>	50
<i>FINAL ASSEMBLY</i>	62

Technical Service Information

GEAR SELECTION

The selector lever has six positions: **P** PARK, **R** REVERSE, **N** NEUTRAL, **D4** 1st through 4th gear ranges, **D3** 1st through 3rd gear ranges, and **2** 2nd gear.

Position	Description
P PARK	Front wheels locked; parking pawl engaged with parking gear on countershaft. All clutches released.
R REVERSE	Reverse; reverse selector engaged with countershaft reverse gear and 4th gear clutch locked.
N NEUTRAL	All clutches released.
D4 DRIVE (1 through 4)	General driving; starts off in 1st, shifts automatically to 2nd, 3rd, then 4th, depending on vehicle speed and throttle position. Downshifts through 3rd, 2nd and 1st on deceleration to stop. The lock-up mechanism comes into operation in 2nd, 3rd and 4th when the transmission is in D4 .
D3 DRIVE (1 through 3)	For rapid acceleration at highway speeds and general driving; starts off in 1st, shifts automatically to 2nd, then 3rd, depending on vehicle speed and throttle position. Downshifts through 2nd to 1st on deceleration to stop.
2 SECOND	For engine braking or better traction starting off on loose or slippery surfaces; stays in 2nd gear, does not shift up or down.

Starting is possible only in **P** and **N** through use of a slide-type, neutral-safety switch.

POSITION INDICATOR

A position indicator in the instrument panel shows what gear has been selected without having to look down at the console.

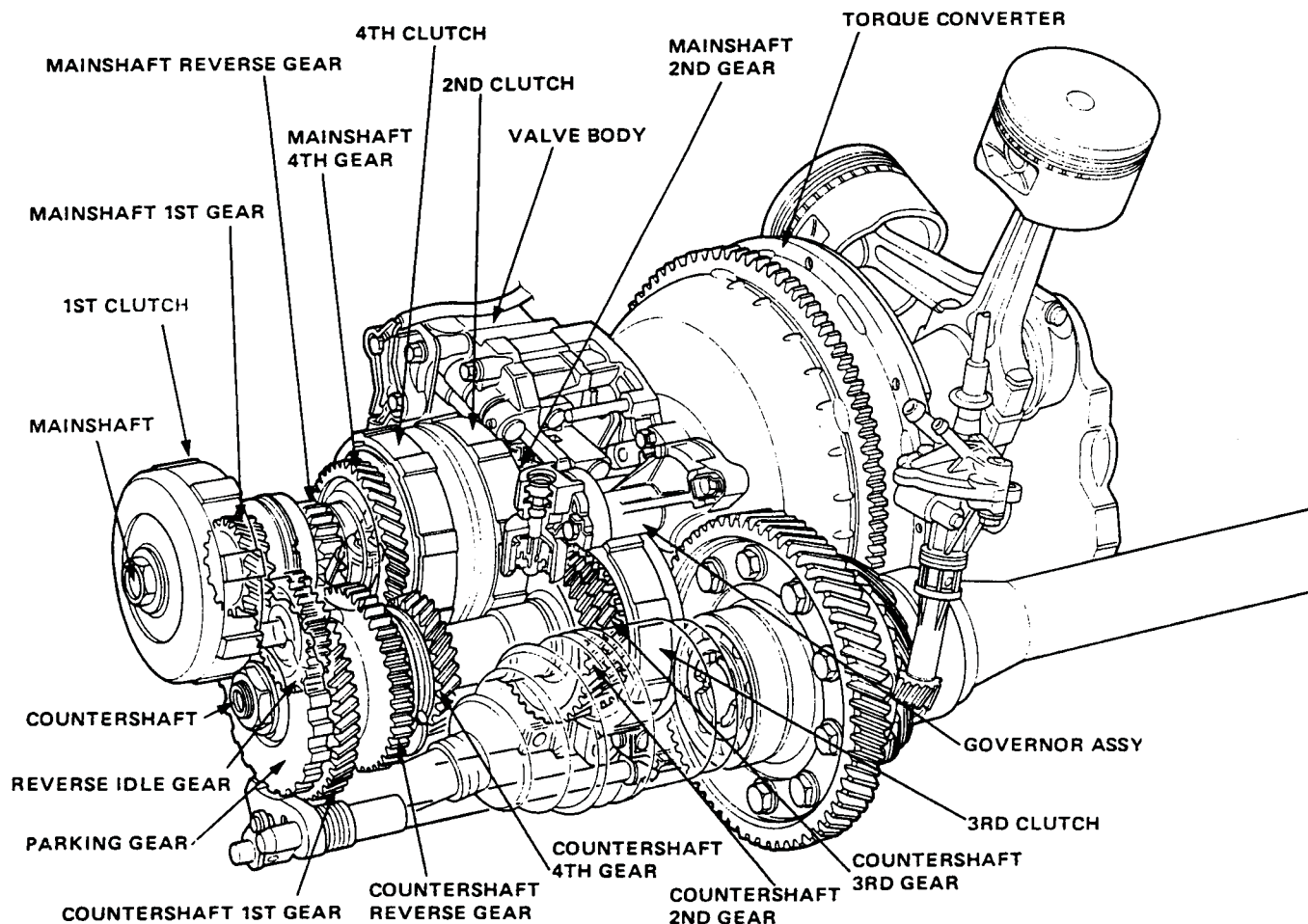

Automatic Transmission Service Group

Technical Service Information

NO.	DESCRIPTION OF PRESSURE	NO.	DESCRIPTION OF PRESSURE	NO.	DESCRIPTION OF PRESSURE	NO.	DESCRIPTION OF PRESSURE
1	LINE	10	1ST CLUTCH	40	4TH CLUTCH	90	TORQUE CONVERTER
2	↑	11	↑	41	↑	91	↑
3	↑	20	2ND CLUTCH	42	↑	92	↑
3'	↑	21	↑	50	THROTTLE A	93	OIL COOLER
3''	↑	22	↑	51	↑	94	TORQUE CONVERTER
4	↑	23	↑	55	THROTTLE B	95	LUBRICATION
4'	↑	24	↑	56	↑	96	TORQUE CONVERTER
5	↑	30	3RD CLUTCH	60	GOVERNOR	97	↑
6	MODULATOR	31	↑	61	↑	99	SUCTION

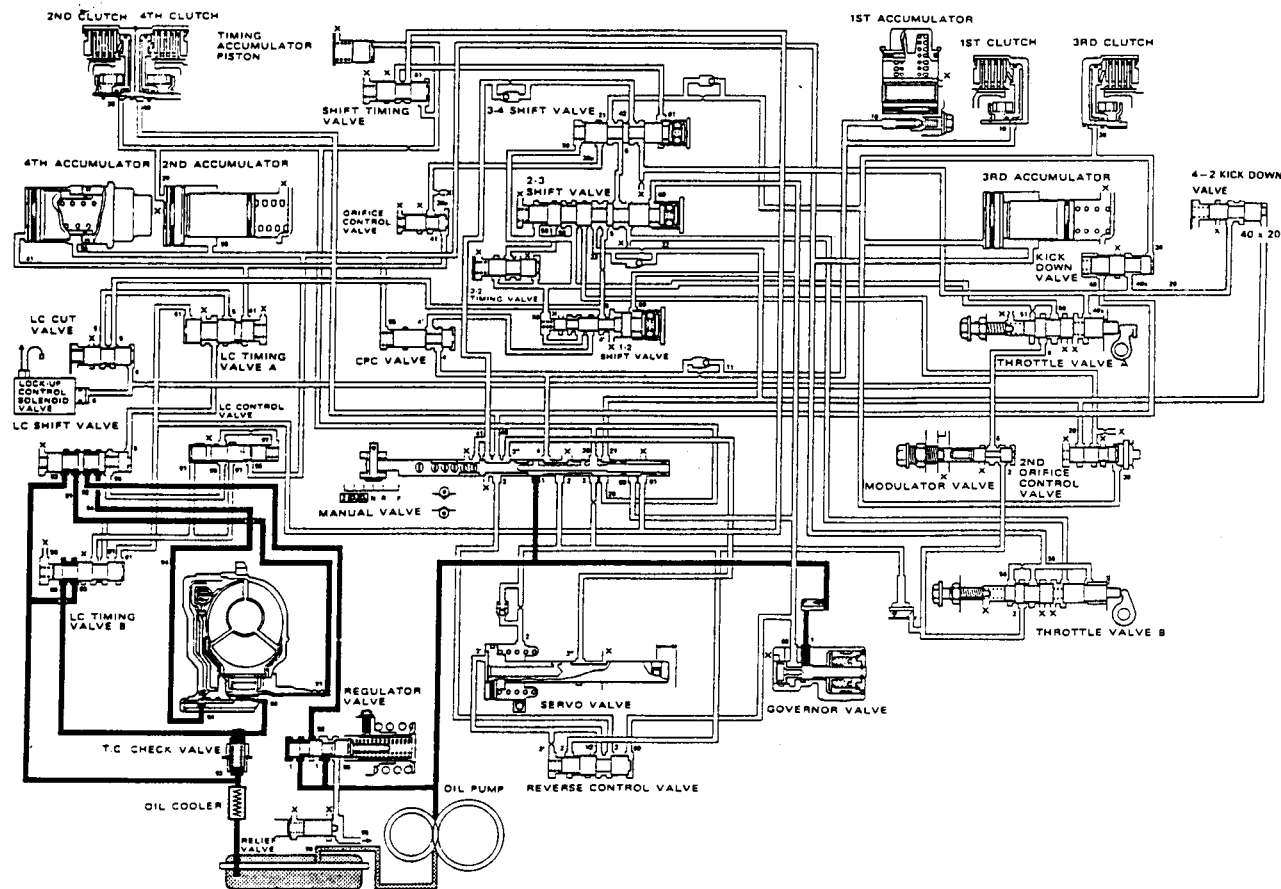

X: BLEED

Technical Service Information

1. Engage parking brake and block front wheels.
2. Connect safety chains to both front tow hooks and attach, with minimum slack, to some strong stationary object.
3. Connect tachometer, and start engine.
4. After engine has warmed up to normal operating temperature, shift into **D3**.
5. Fully depress brake pedal and accelerator for 6 to 8 seconds, and note engine speed.

CAUTION: To prevent transmission damage, do not test stall speed for more than 10 seconds at a time.

6. Allow 2 minutes for cooling, then repeat same test in **D4**, **2** and **R**.

Stall speed in **D3**, **D4**, **2**, and **R** must be the same, and must also be within limits:

Stall Speed RPM:

Specification: 2,600 rpm
Service Limit: 2,450–2,750 rpm

TROUBLE	PROBABLE CAUSE
Stall rpm high in 2 , D3 , D4 & R .	Low fluid level or oil pump output, clogged oil strainer, pressure regulator valve stuck closed. Slipping clutch.
Stall rpm high in D3 , D4 only.	Slippage of 1st clutch
Stall rpm low in 2 , D3 , D4 & R .	<ul style="list-style-type: none"> • Engine output low, throttle cable misadjusted. • Oil pump seized. • Torque converter one-way clutch slipping.

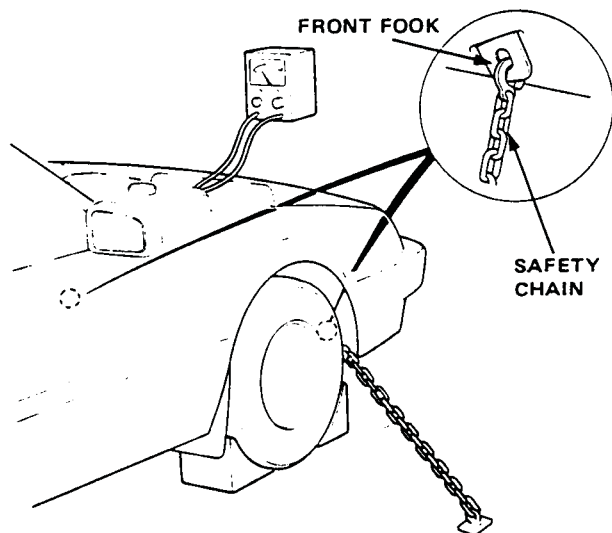

Checking

With the car on level ground, pull the transmission dipstick and check the level of fluid immediately after the engine is shut off (within one minute). The fluid level should be between the full and low marks. Push the dipstick all the way in to check the fluid level. If the level is at, or below, the low mark, add DEXRON-type automatic transmission fluid.

Changing

1. Bring the transmission up to operating temperature by driving the car. Park the car on level ground, turn the engine off, then remove drain plug.
2. Reinstall the drain plug with a new washer, then refill the transmission to the full mark on the dipstick.

Automatic transmission Capacity:

3.2 l (3.4 U.S. qts., 2.8 Imp. qt) at change
6.5 l (6.9 U.S. qts., 5.7 Imp. qt) after overhaul

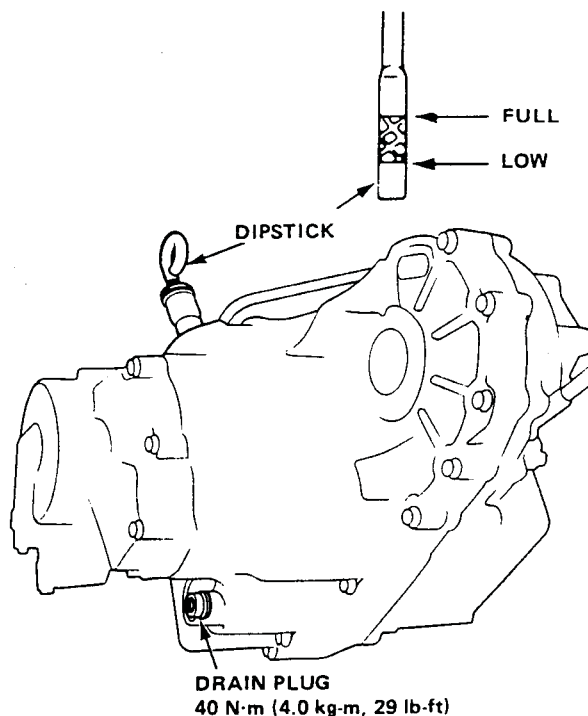

Technical Service Information

1. Remove the suction pipe.

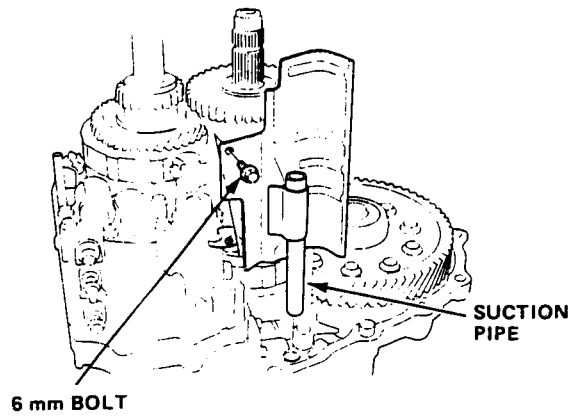

2. Remove the reverse gear collar, countershaft reverse gear and needle bearing.

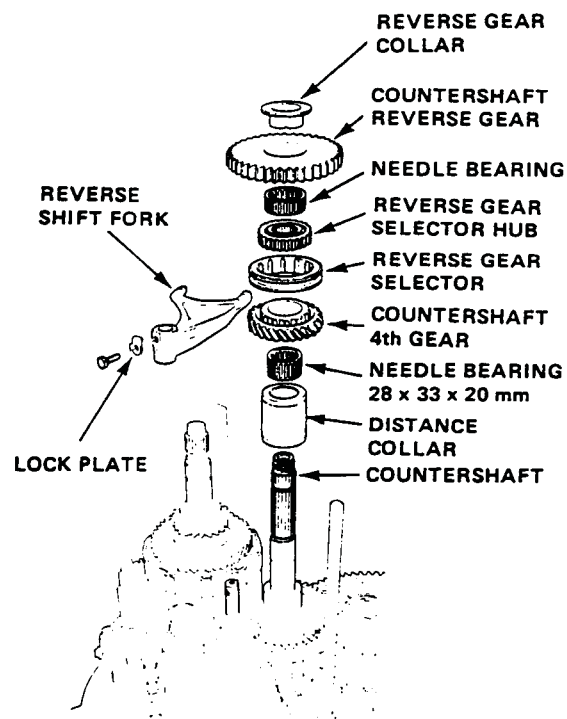

3. Bend down the tab on the lock plate and remove the bolt from the reverse shift fork.
4. Remove the reverse shift fork and reverse gear selector as a unit.
5. Remove the selector hub, countershaft 4th gear, needle bearing and distance collar.

6. Remove the mainshaft and countershaft together.

NOTE: It will be necessary to pull up the countershaft at a slight angle to clear the governor.

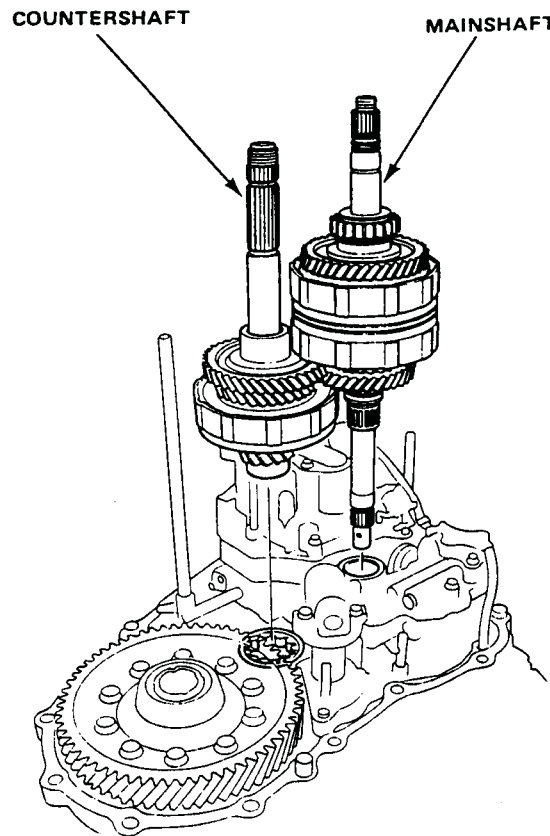

Technical Service Information

Removal (cont'd)

4. Turn the torque converter housing over and remove the control shaft.

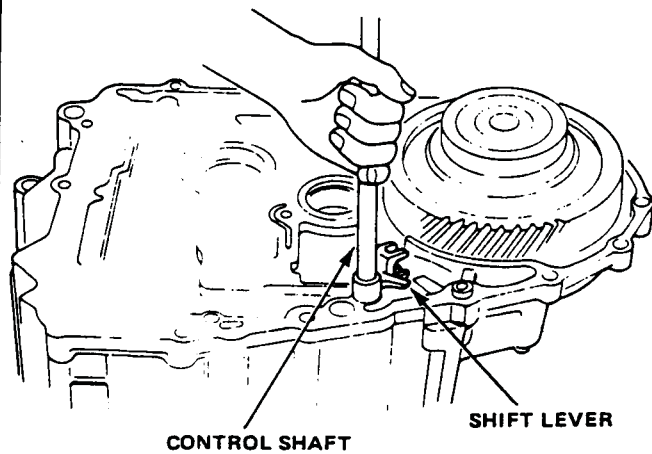

Disassembly/Reassembly

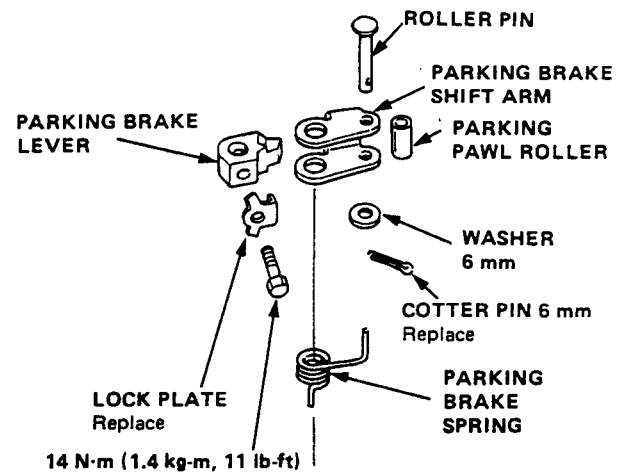

NOTE:

These parts are installed on the shaft after the transmission and torque converter housings are assembled.

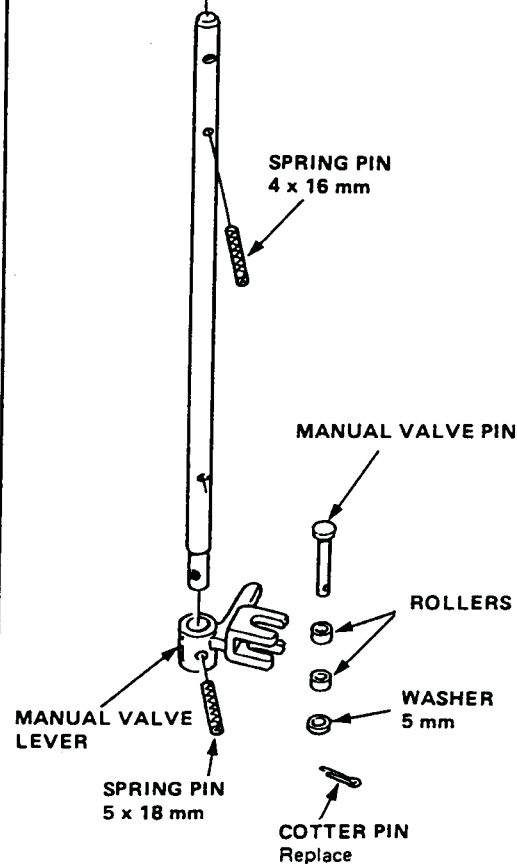

Technical Service Information

Disassembly/Inspection

NOTE:

- Clean all parts thoroughly in solvent or carburetor cleaner.
- Replace valve body as assembly if any parts are worn or damaged.
- Check all valves for free movement, if any fail to slide freely,
- Coat all parts with ATF before reassembly.

1. Hold the retainer in place while removing the lock bolt. Once the bolt is removed, release the retainer slowly.

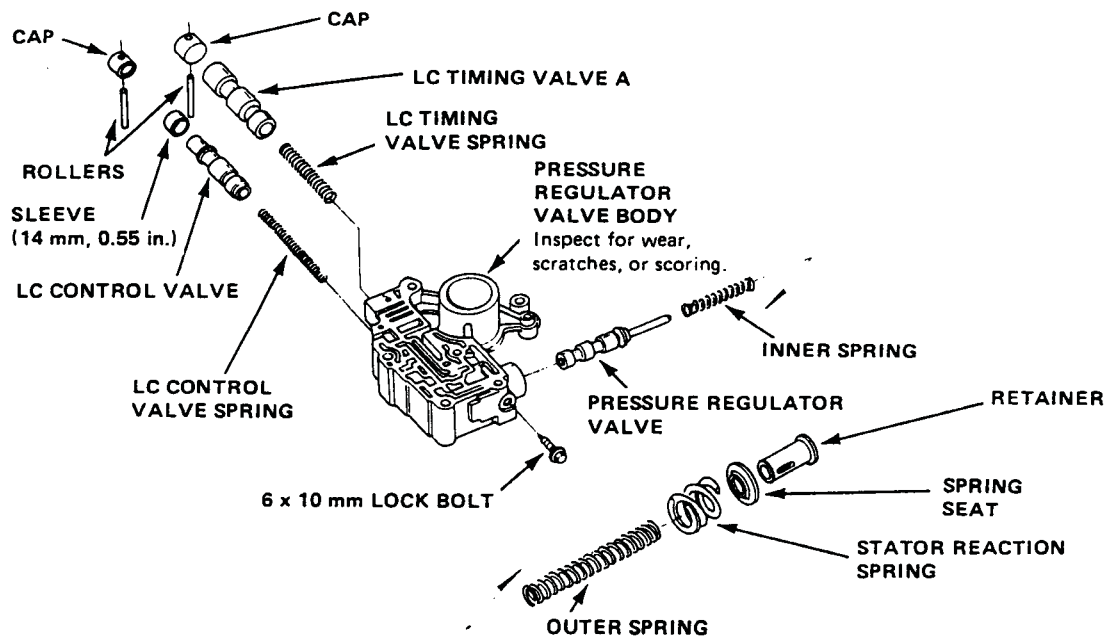

Reassembly

1. Clean all parts thoroughly in solvent or carburetor cleaner, and dry with compressed air. Blow out all passages.
2. Coat all valves with ATF.
3. Install the pressure regulator valve, and the inner and outer springs.
4. Install the reaction spring, spring seat, and retainer. Align the hole in the retainer with the hole in the valve body, then press the retainer into the valve body and tighten the lock bolt.

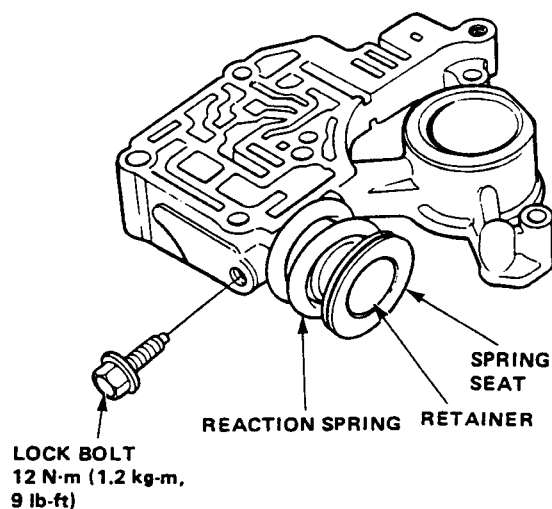

Technical Service Information

NOTE:

- The 1st and 3rd clutch assemblies are identical except installing the spring washer in the 1st clutch.
 - The 2nd and 4th clutch assemblies are identical except installing the spring washer in the 2nd clutch.
 - The 2nd clutch spring washer faces the opposite direction of the 1st, 3rd and 4th clutch spring washers.
 - To reassemble the 2nd/4th clutch, use the special tool in Step 7 in the same manner as for the 1st and 3rd clutches.
1. Clean all parts thoroughly in solvent, and dry with compressed air. Blow out all passages.
 2. Lubricate all parts with ATF before reassembly.

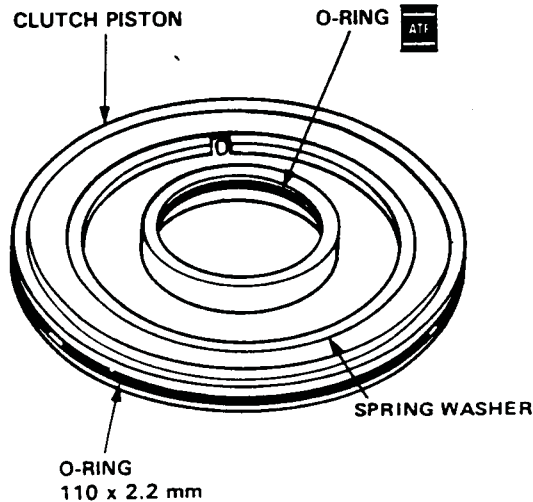

3. Install new O-ring on clutch piston. Make sure the spring washer is properly positioned as shown.

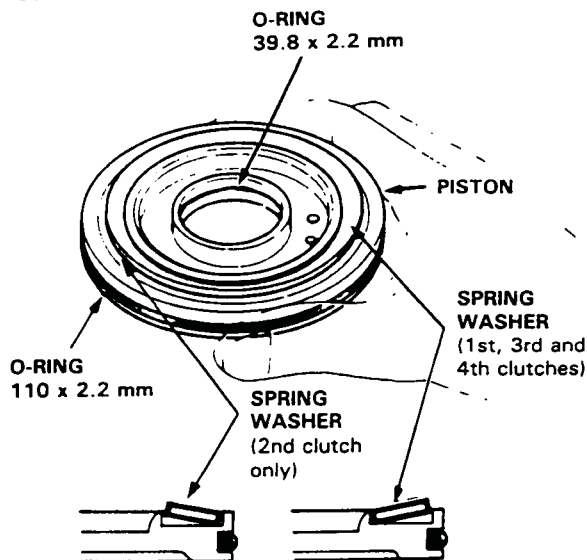

4. Install the piston in the clutch drum. Apply pressure and rotate to ensure proper seating.

NOTE: Lubricate the piston O-ring with ATF before installing.

CAUTION: Do not pinch O-ring by forcing piston installation.

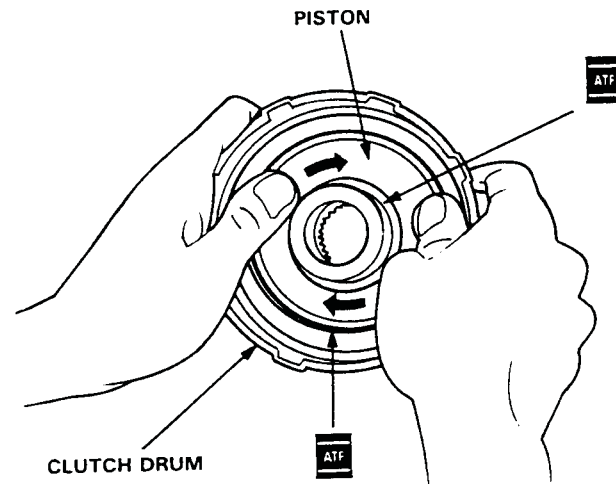

1st clutch:
Install the spring washer.

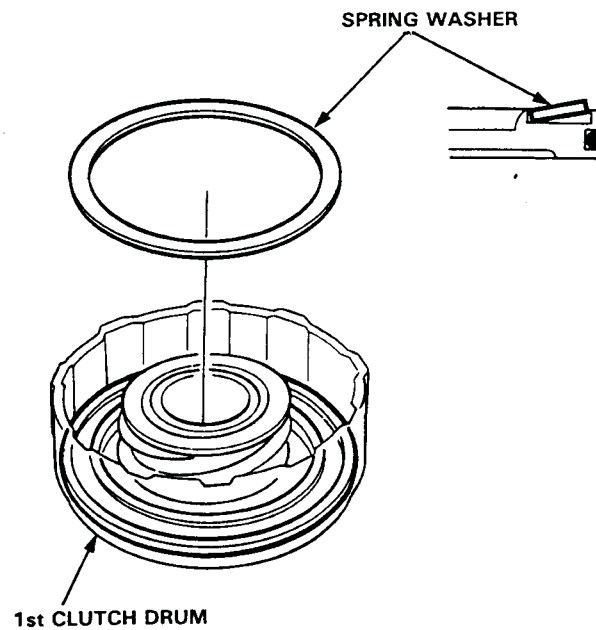

Technical Service Information

Disassembly/Inspection

CAUTION: Remove and install parts carefully to avoid damaging them.

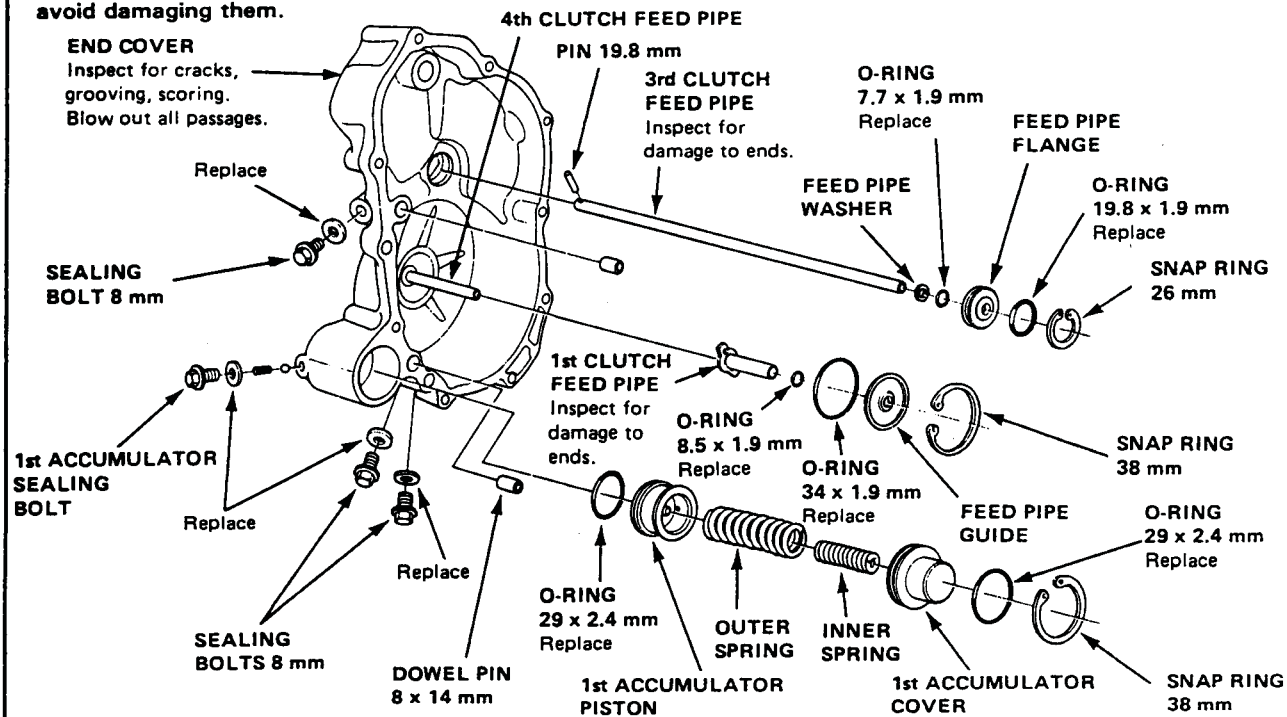

Reassembly

1. Seat a new O-ring in the groove of the 1st accumulator, and slide the accumulator piston into the right side transmission cover. Install the outer spring, inner spring, another new O-ring and the accumulator cover, in that order.

2. Install 38 mm snap ring.

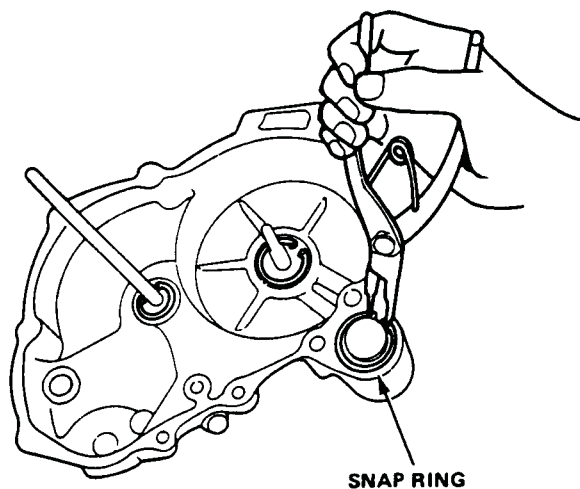

3. With feed pipes assembled, align lugs on the collars with slot in end cover.

4. Install the snap ring.

5. Install the feed pipes in the end cover, aligning the lugs of the 1st clutch feed pipe with the grooves of the end cover.

6. Install the snap ring.

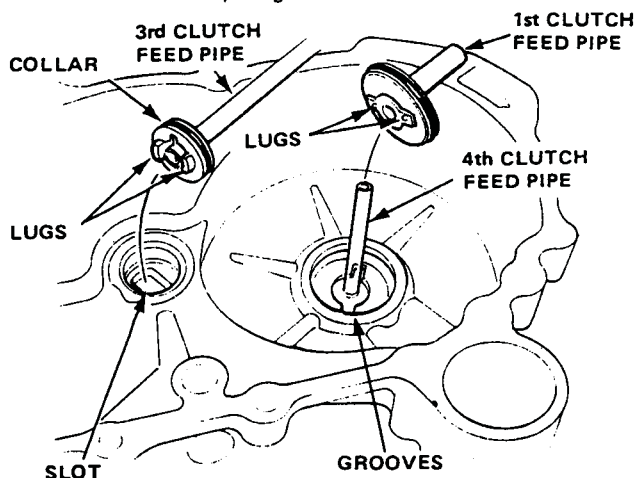

Technical Service Information

24. Put the rollers on each side of the manual valve stem, then attach the valve to the lever with the pin. Secure with the cotter pin.

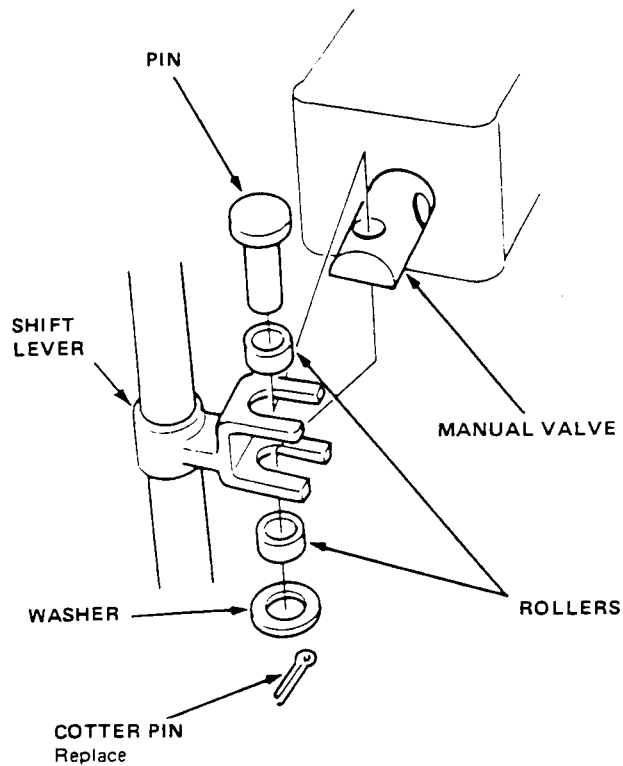

25. Install the 1st, 3rd and 4th clutch feed pipes.

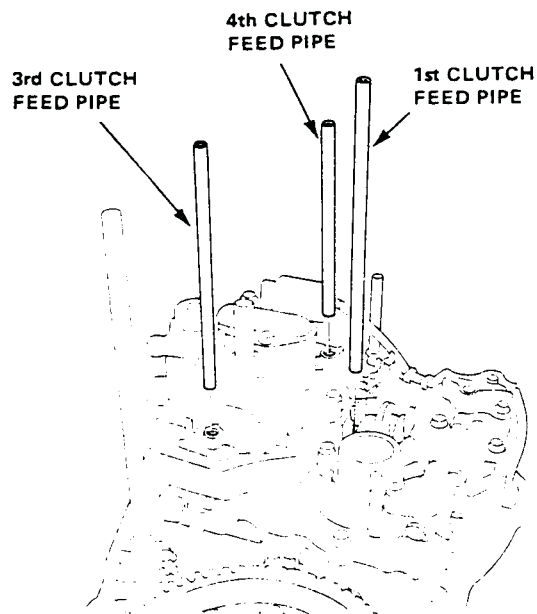

26. Install the governor valve using new lock plates, and the three 6 mm bolts.

BOLTS
M6 x 1.0 mm, 12 N·m (1.2 kg·m, 9 lb·ft)

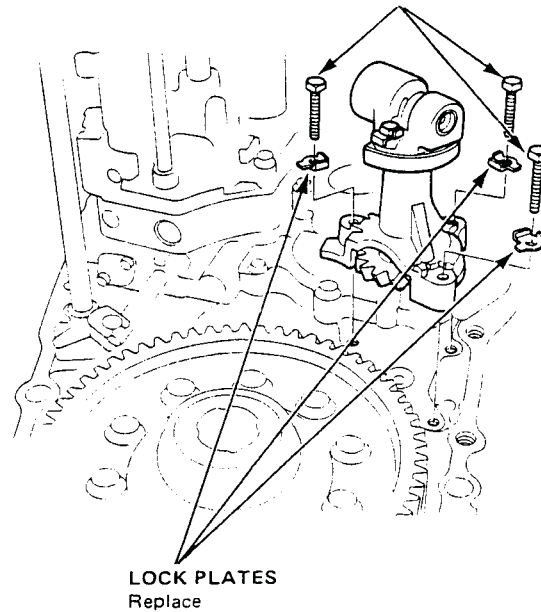

27. Set the countershaft and mainshaft in place as an assembly.

NOTE: Do not tap on the shafts with a hammer to drive in.

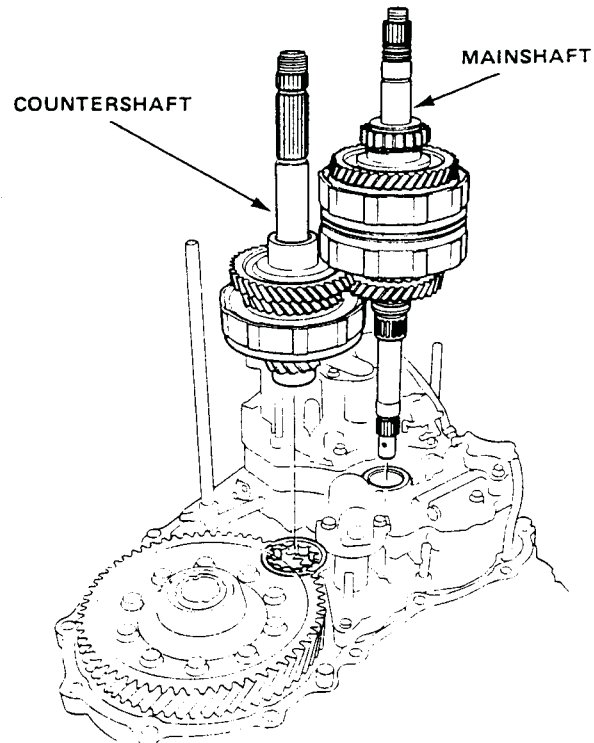

Technical Service Information

38. Tighten the reverse idler bearing holder bolts.

39. Install the spring and steel ball.

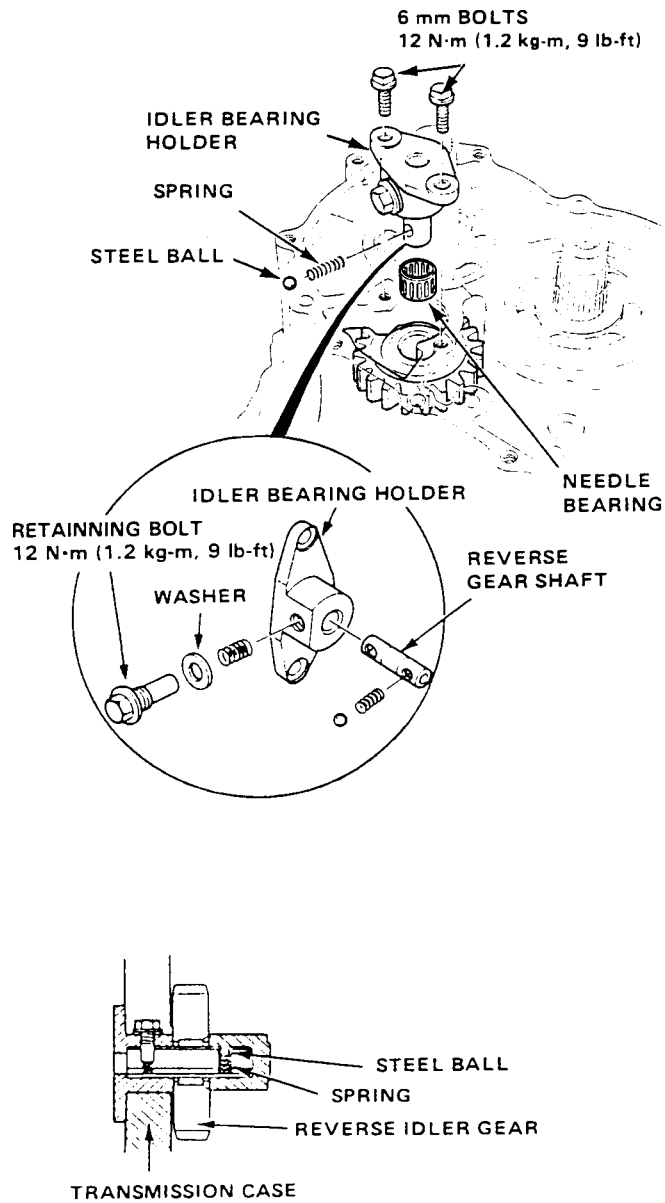

40. Place the transmission housing on the torque converter housing.

NOTE: Be sure the main valve control shaft lines up with the hole in the housing and that the reverse idler gear meshes with the mainshaft and countershaft, or the housing will not go on.

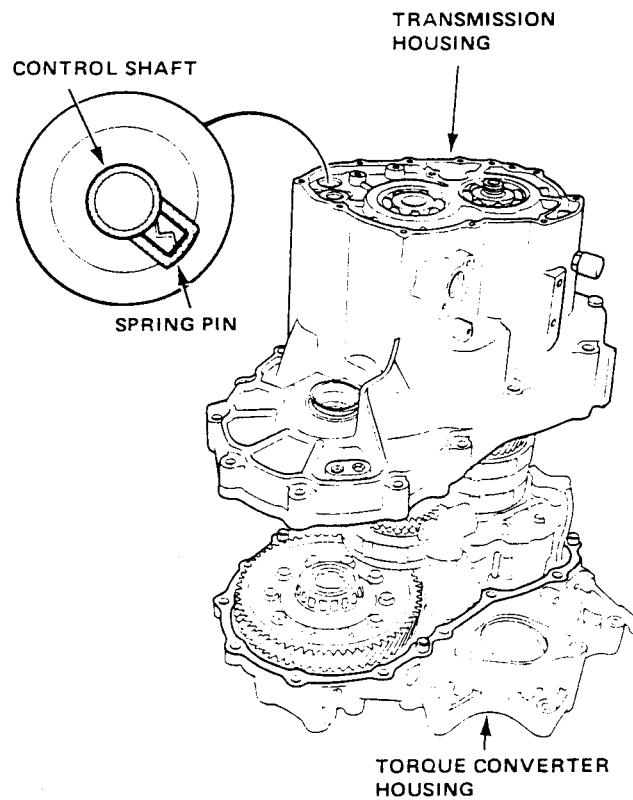

(cont'd)

Technical Service Information

48. Install the countershaft 1st gear and parking gear on the countershaft.

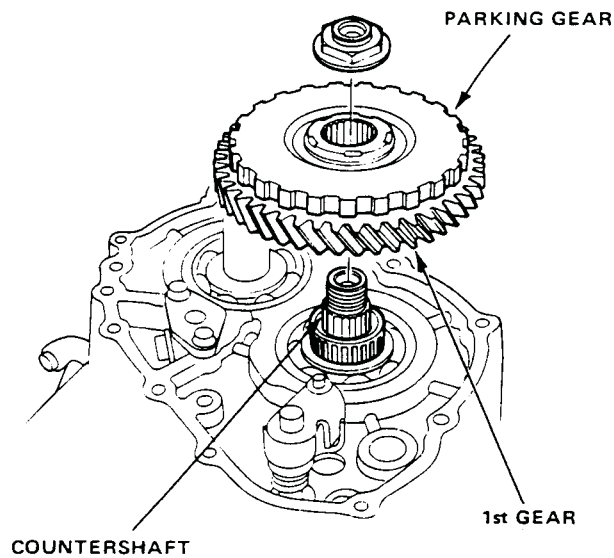

49. Install the stop pin, parking pawl shaft, parking pawl, and pawl release spring.

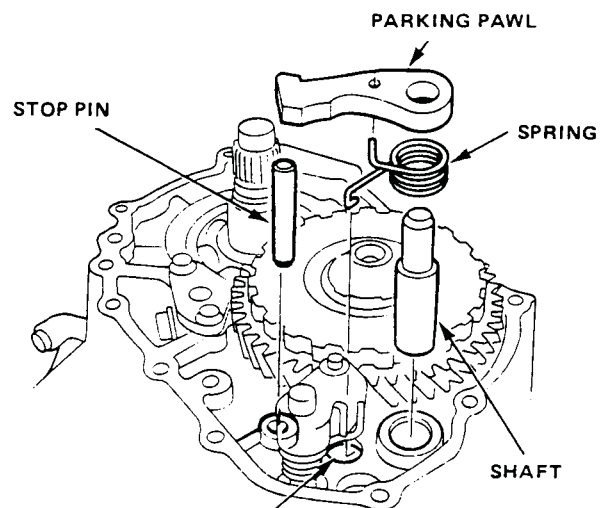

Hook end of spring into this hole.

NOTE:

- One end of the parking pawl release spring fits into the hole in the parking pawl, the other end into the hole in the transmission housing as shown.
- The release spring should put clockwise tension on the pawl, forcing it away from the parking gear.

50. Shift to PARK and install the mainshaft holder.
51. Install and torque the new countershaft locknut.

CAUTION: Locknut has left-hand threads.

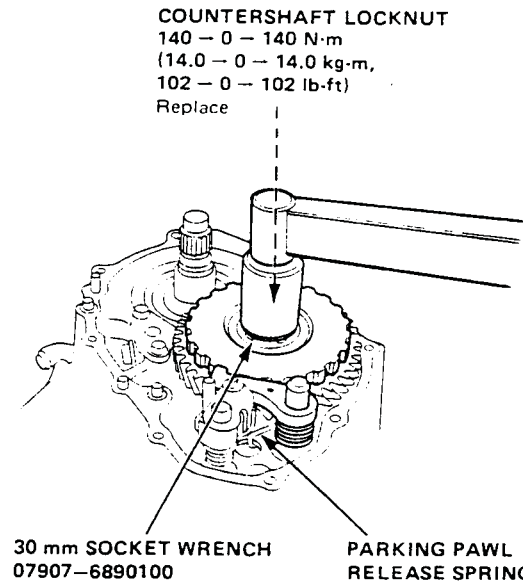

COUNTERSHAFT LOCKNUT
140 - 0 - 140 N·m
(14.0 - 0 - 14.0 kg·m,
102 - 0 - 102 lb·ft)
Replace

52. Stake the locknut flange at two places into the gear grooves using a 3.5 mm punch.

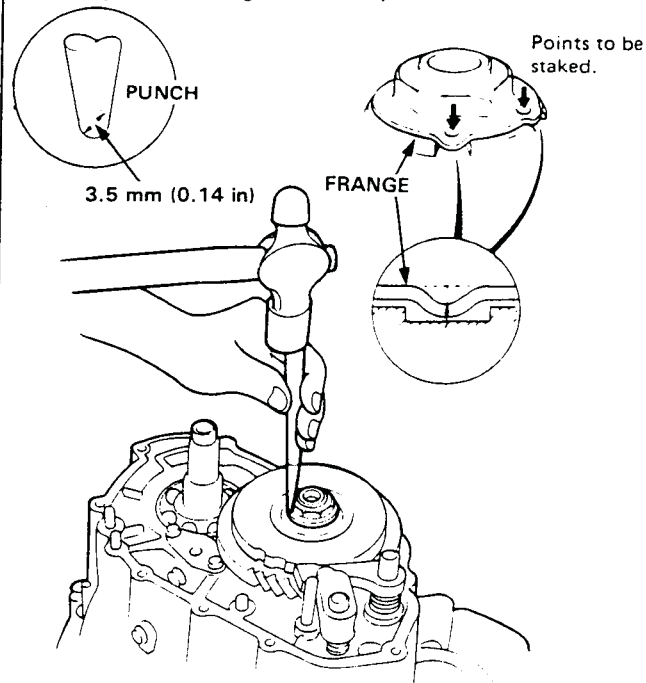

(cont'd)

Technical Service Information

59. Install the gasket, dowel pins, and O-rings on the transmission housing.

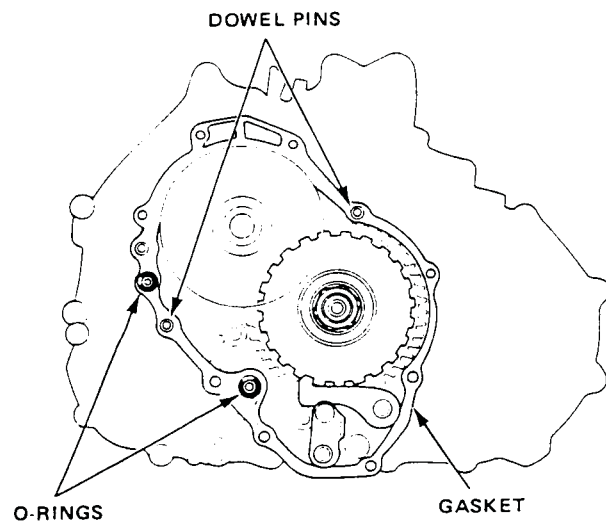

60. Install the end cover and torque all 9 bolts to 12 N·m (1.2 kg-m, 9 lb-ft).

61. Install the transmission cooler banjo fitting, but do not tighten until the transmission is installed in the car and the hose is positioned properly.

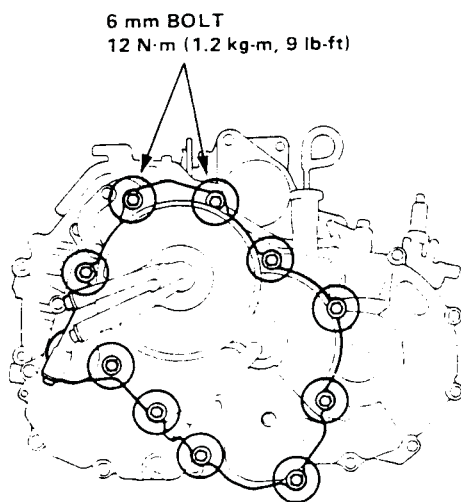

62. Install the transmission cooler hose fitting and torque to 29 N·m (2.9 kg-m, 21 lb-ft).

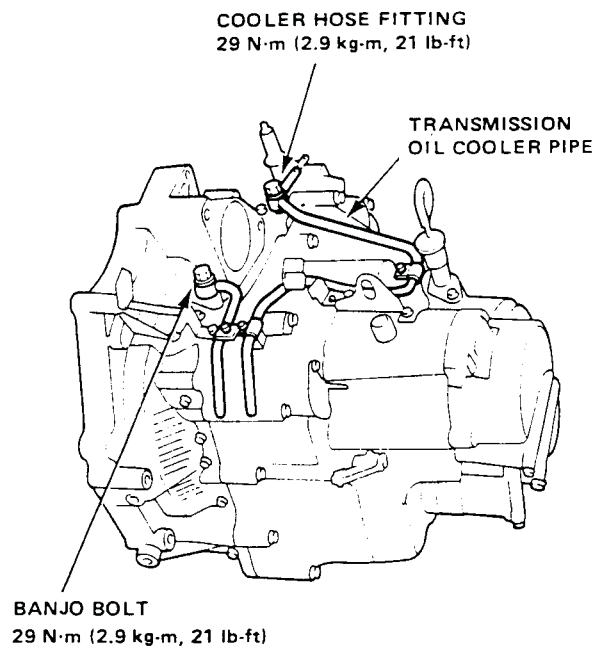

Technical Service Information

1. Place the transmission on the transmission jack and raise to the engine level.
2. Secure the transmission to the engine with the mounting bolts.
3. Install the starter.
4. Attach the torque converter to the drive plate with mounting bolts, and torque to 10 N·m (1.0 kg-m, 8 lb-ft). Rotate the crank as necessary to tighten bolts to 1/2 torque, then final torque, in a criss-cross pattern. Check for free rotation after tightening the last bolt.
5. Install the transmission to the rear engine mount bracket with two bolts.

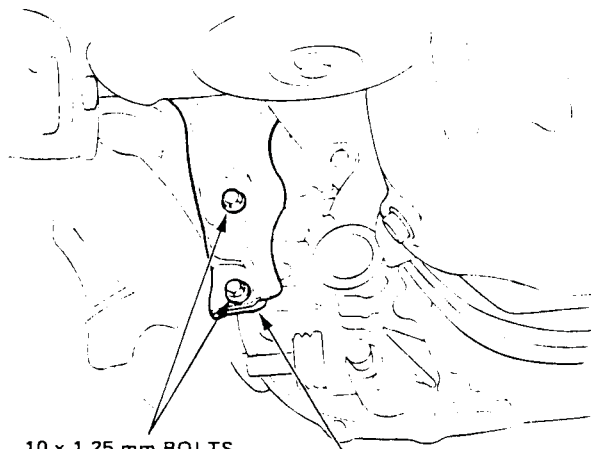

10 x 1.25 mm BOLTS
39 N·m (3.9 kg-m, 29 lb-ft) REAR ENGINE MOUNT BRACKET

6. Install the torque converter cover.

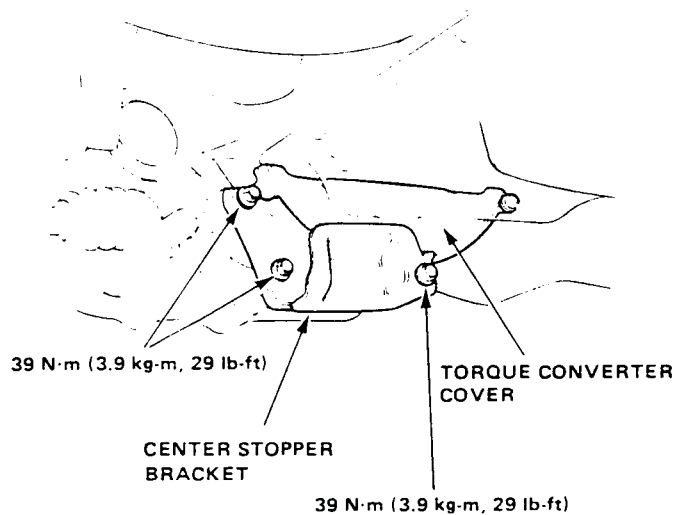

39 N·m (3.9 kg-m, 29 lb-ft) TORQUE CONVERTER COVER
CENTER STOPPER BRACKET
39 N·m (3.9 kg-m, 29 lb-ft)

7. Install the center stopper bracket to the transmission.
8. Install the center beam.
9. Connect the radius rod.
10. Install the front engine mount bolts and torque to 39 N·m (3.9 kg-m, 29 lb-ft).

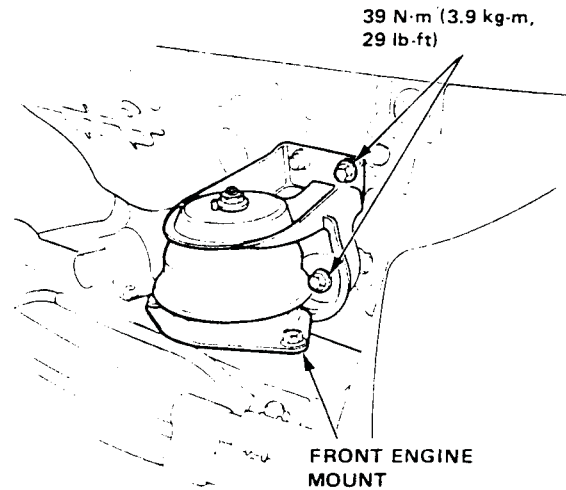

39 N·m (3.9 kg-m, 29 lb-ft)

FRONT ENGINE MOUNT

11. Remove the chain hoist by removing the two 10 mm bolts.
12. Install the torque rod bracket and torque the bolts to 39 N·m (3.9 kg-m, 29 lb-ft).

NOTE: Replace the bolts with new ones whenever loosened or removed.

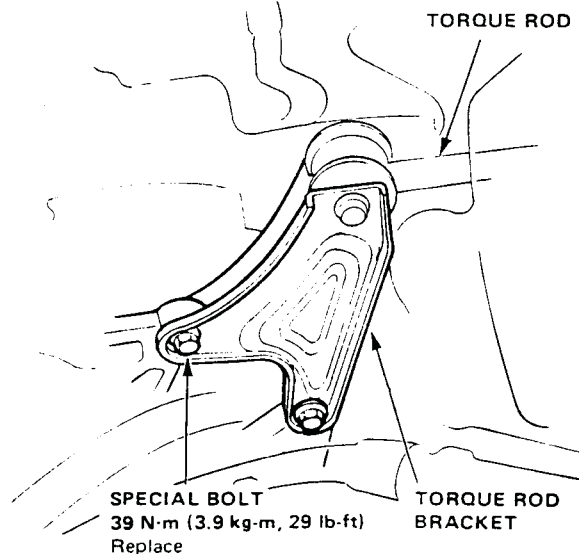

TORQUE ROD
SPECIAL BOLT
39 N·m (3.9 kg-m, 29 lb-ft) Replace
TORQUE ROD BRACKET

13. Remove the transmission jack.

(cont'd)

Technical Service Information

HONDA TRANSMISSION APPLICATION CHART

	2-SPEED	3-SPEED	3-SP LOCKUP	4-SP 4.165*	4-SP 4.325*	4-SP 4.325**	4-SP 4.550*	4-SP 4.550**
CIVIC 73-80	■							
CIVIC 81-83		■						
CIVIC 84-85			■					
CIVIC 86-87				■				
CIVIC 88-UP					■			
ACCORD PRELUDE 73-79	■							
ACCORD PRELUDE 80-82		■						
ACCORD 83			■					
ACCORD 84-85				■				
ACCORD 86-89							■	
PRELUDE 83-84				■				
PRELUDE (CARB.) 85-87				■				
PRELUDE (F.I.) 85-UP							■	
INTEGRA 86-89						■		
LEGEND 86-UP								■

◆ NOTE: AXLE SEALS FOR 1985 ACCORD LXI (F.I.) NOT INCLUDED ORDER (1) 29305 AND (1) 29304 SEPARATELY.

◆ NOTE: AXLE SEALS FOR 1988-UP PRELUDE NOT INCLUDED ORDER (1) 29413 AND (1) 29414 SEPARATELY.

* MEASUREMENT OF FRICTION PLATE † ACURA * 1988-UP

2-SPEED	3-SPEED ALL	4-SPEED	4-SPEED	4-SPEED 1988-UP	4-SPEED ACURA	4-SPEED	4-SPEED ACURA
	4.165* O.D.	4.165* O.D.	4.325* O.D.	4.325* O.D.	4.325* O.D.	4.550* O.D.	4.550* O.D.
1113	1114	1115	1115	1115	1115	1182	1183
2113	2114	2115	2115 ◆	2184	2185	2182 ◆	2183