

A63
Skid Control ECU Assembly

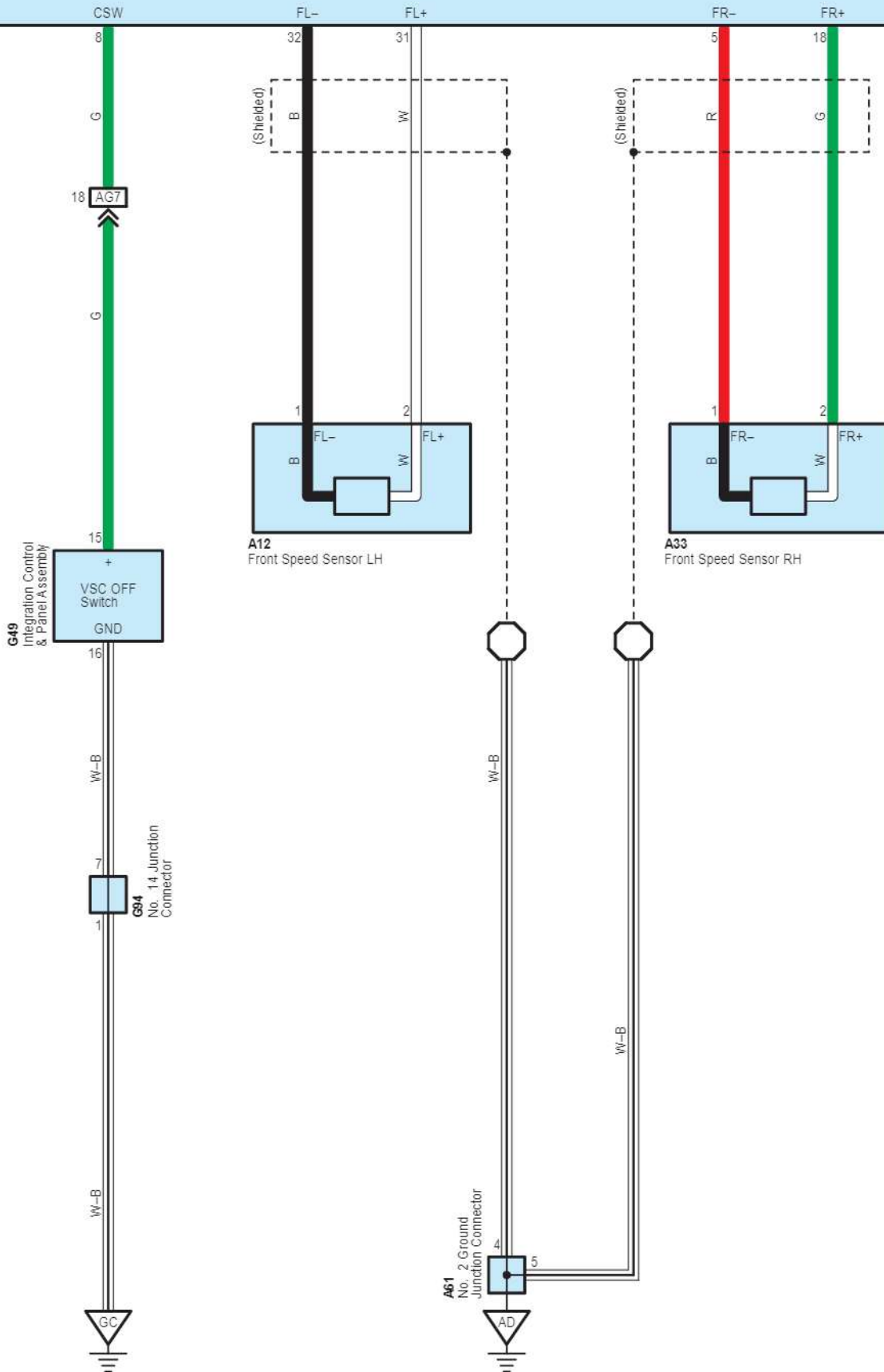

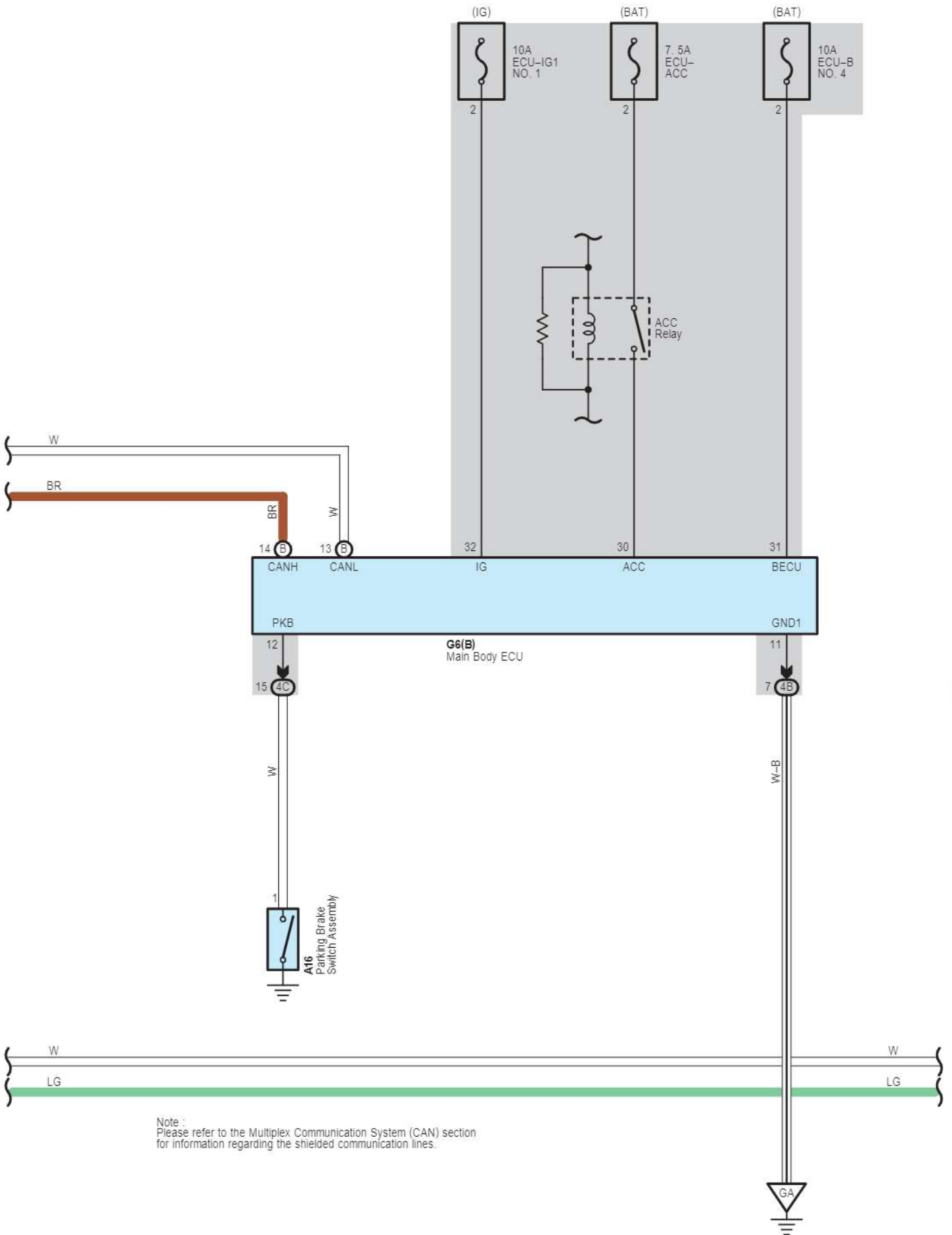

Note:
Please refer to the Multiplex Communication System (CAN) section for information regarding the shielded communication lines.

ABS, Hill-Start Assist Control, TRC, VSC

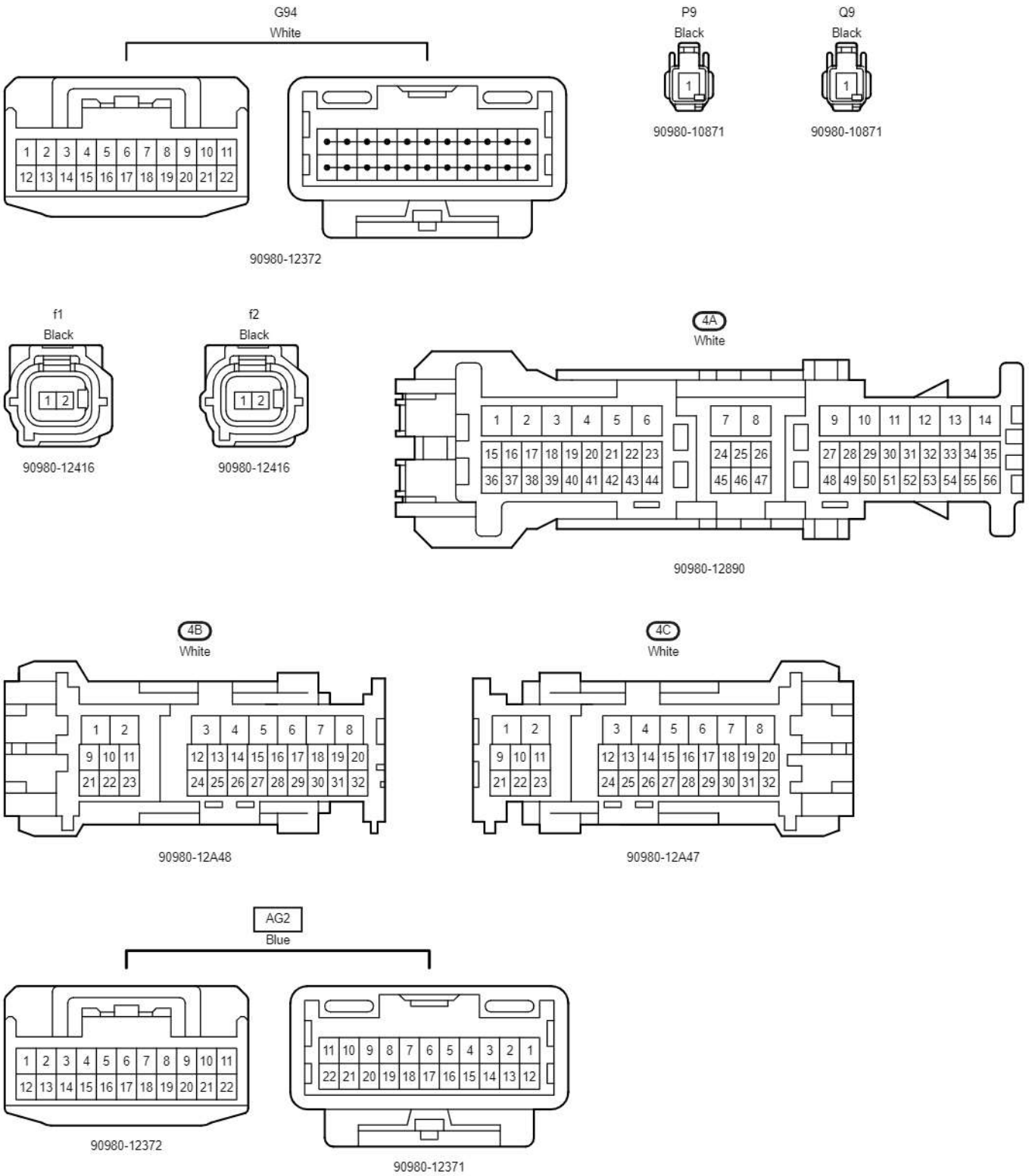

Air Conditioner

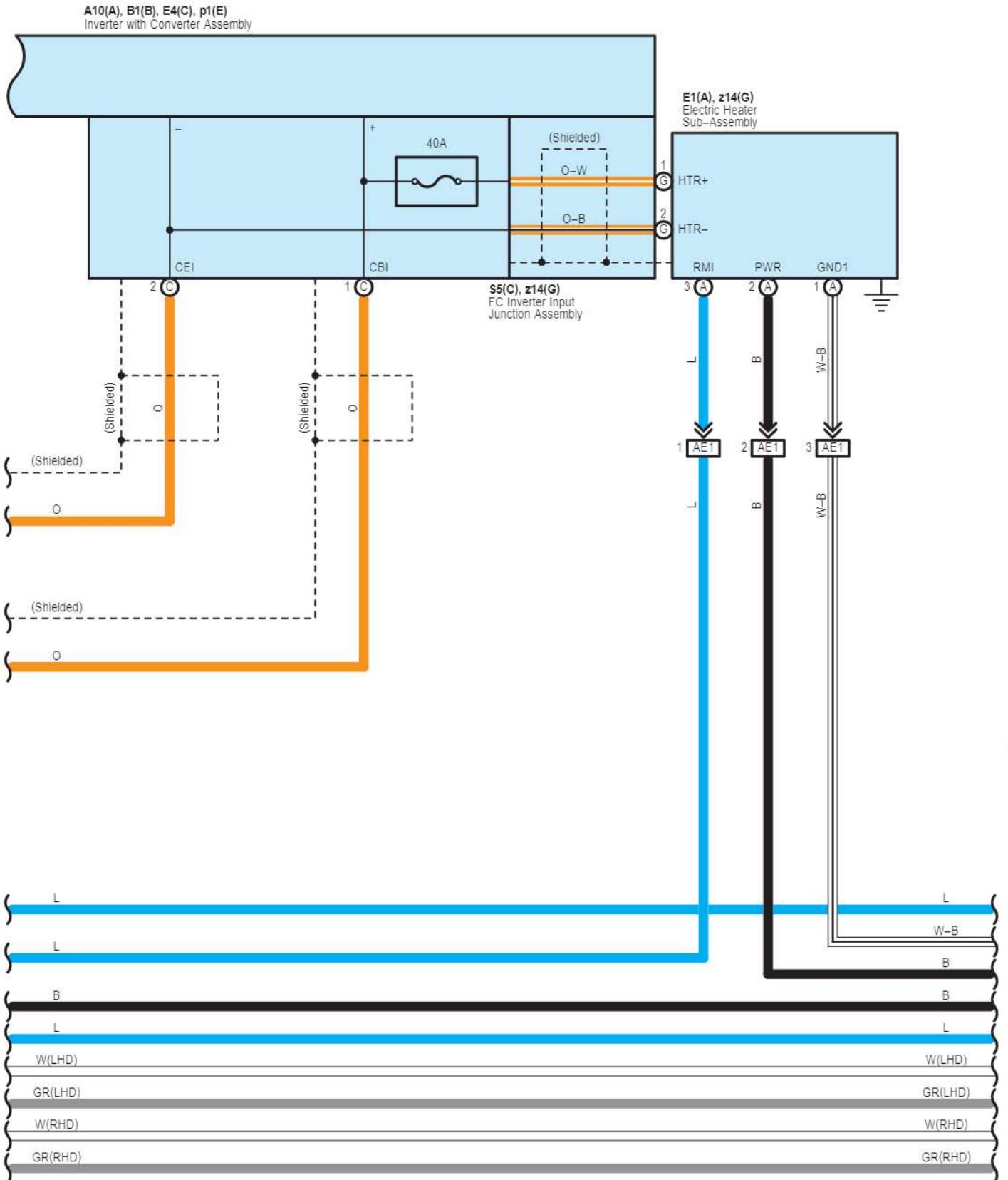

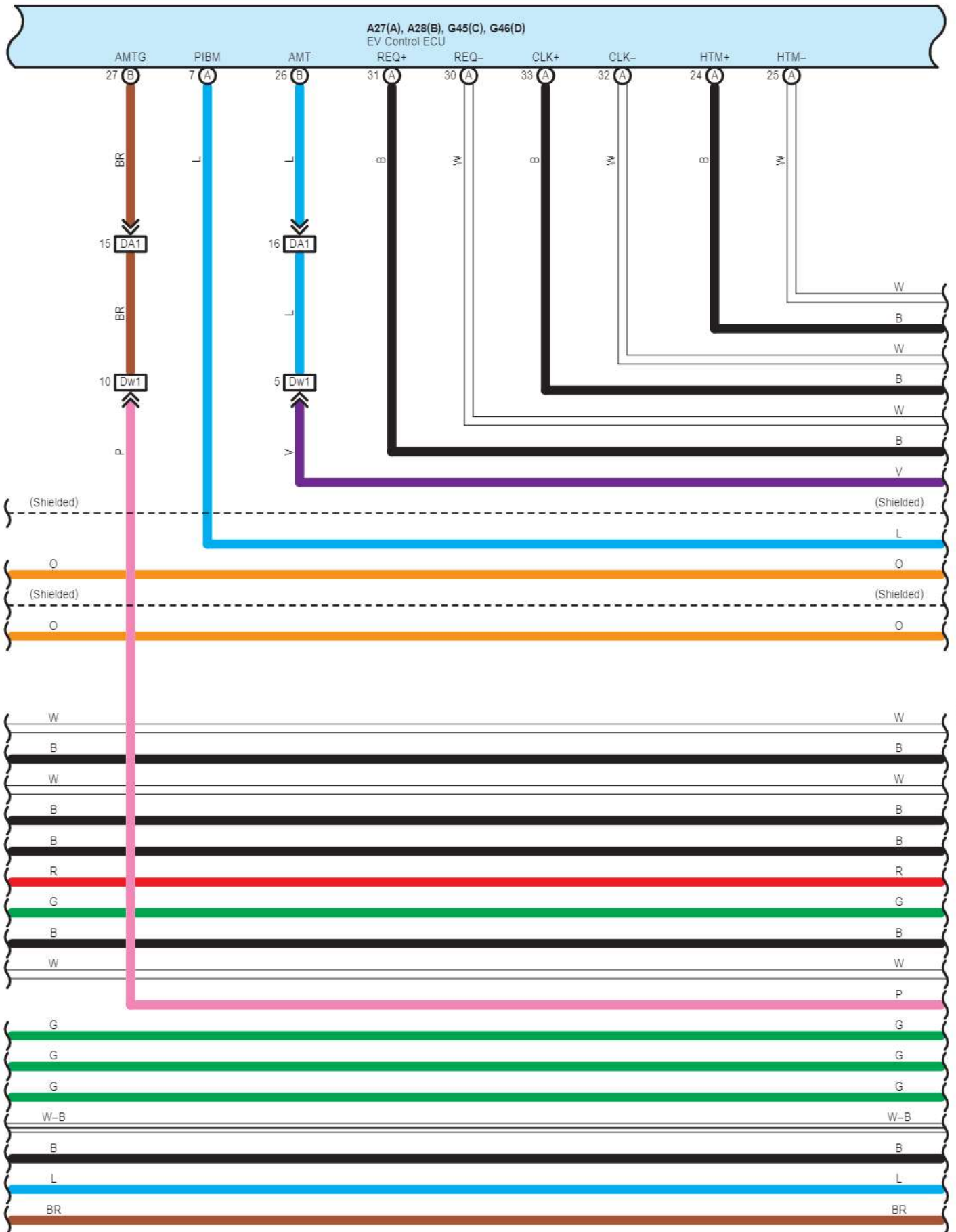

A47(A), A48(B)
FC Control ECU

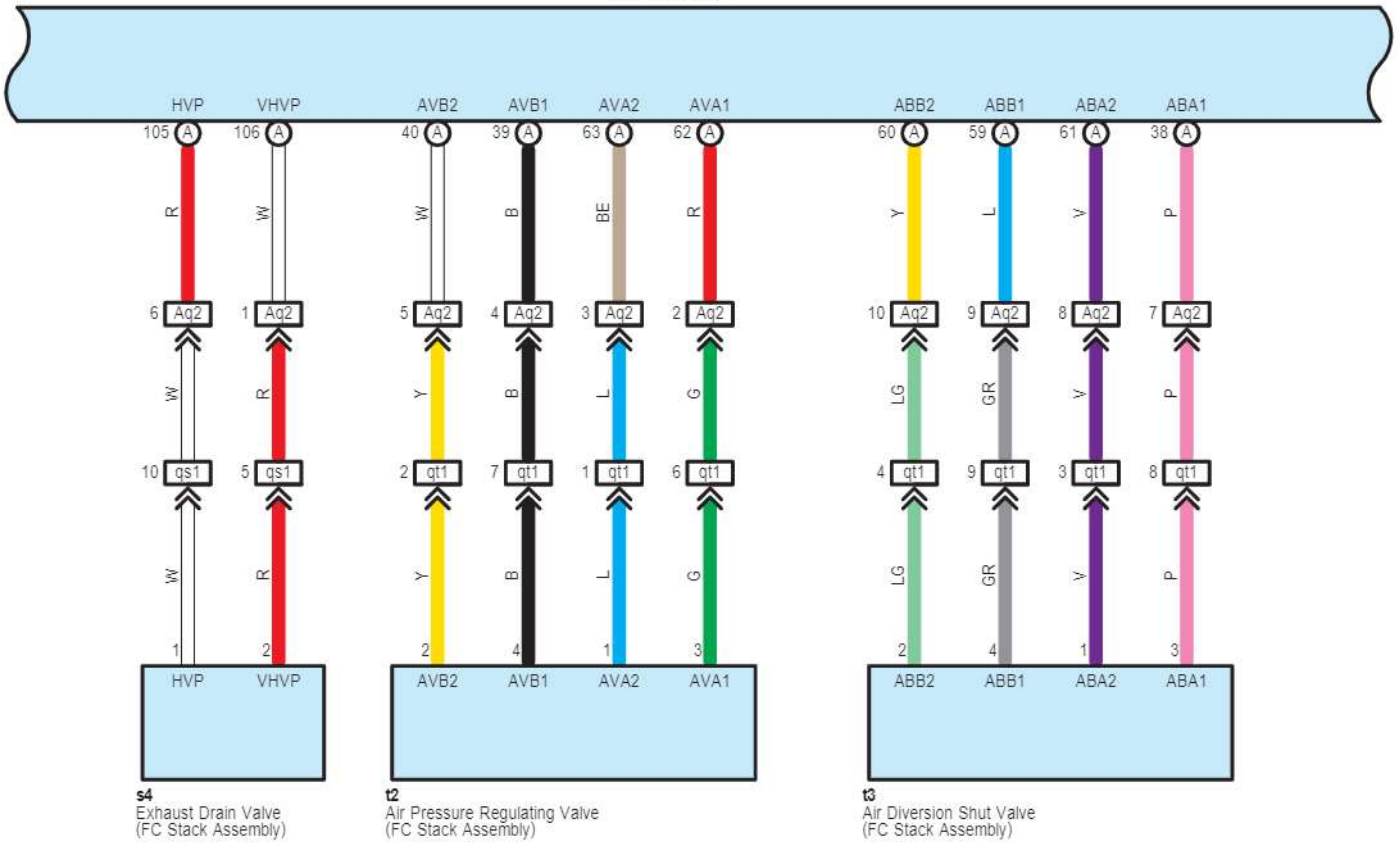

z25(A), z26(B), z27(C), z28(D), z29(E), z30(F), z31(G), z32(H), z33(I), z34(J), z35(K), z36(L), z37(M), z38(N), z39(O), z40(P),
 z41(Q), z42(R), z43(S), z44(T), z45(U), z46(V), z47(W), z48(X), z49(Y), z50(Z), z51(a), z52(b), z53(c), z54(d), z55(e)
 Fuel Cell (FC Stack Assembly)

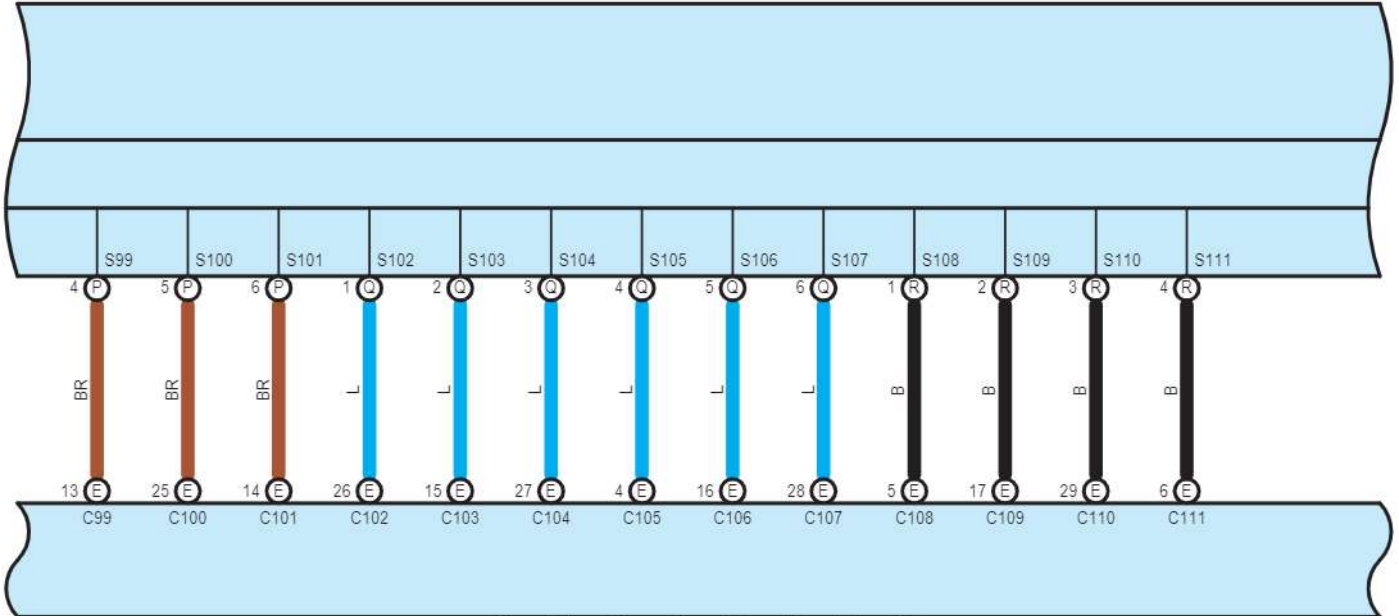

u1(A), z18(B), z19(C), z20(D), z21(E), z22(F), z23(G), z24(H)
 FC Stack Voltage Sensor (FC Stack Assembly)

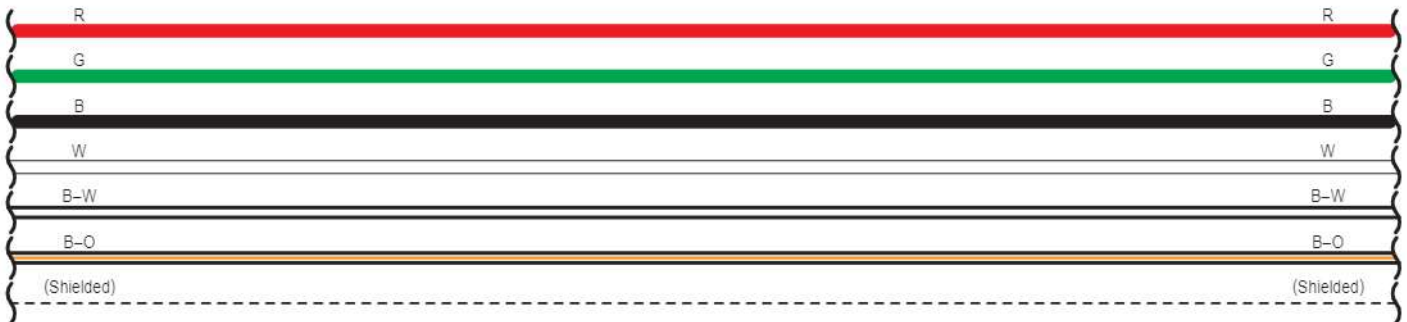

z25(A), z26(B), z27(C), z28(D), z29(E), z30(F), z31(G), z32(H), z33(I), z34(J), z35(K), z36(L), z37(M), z38(N), z39(O), z40(P),
 z41(Q), z42(R), z43(S), z44(T), z45(U), z46(V), z47(W), z48(X), z49(Y), z50(Z), z51(a), z52(b), z53(c), z54(d), z55(e)
 Fuel Cell (FC Stack Assembly)

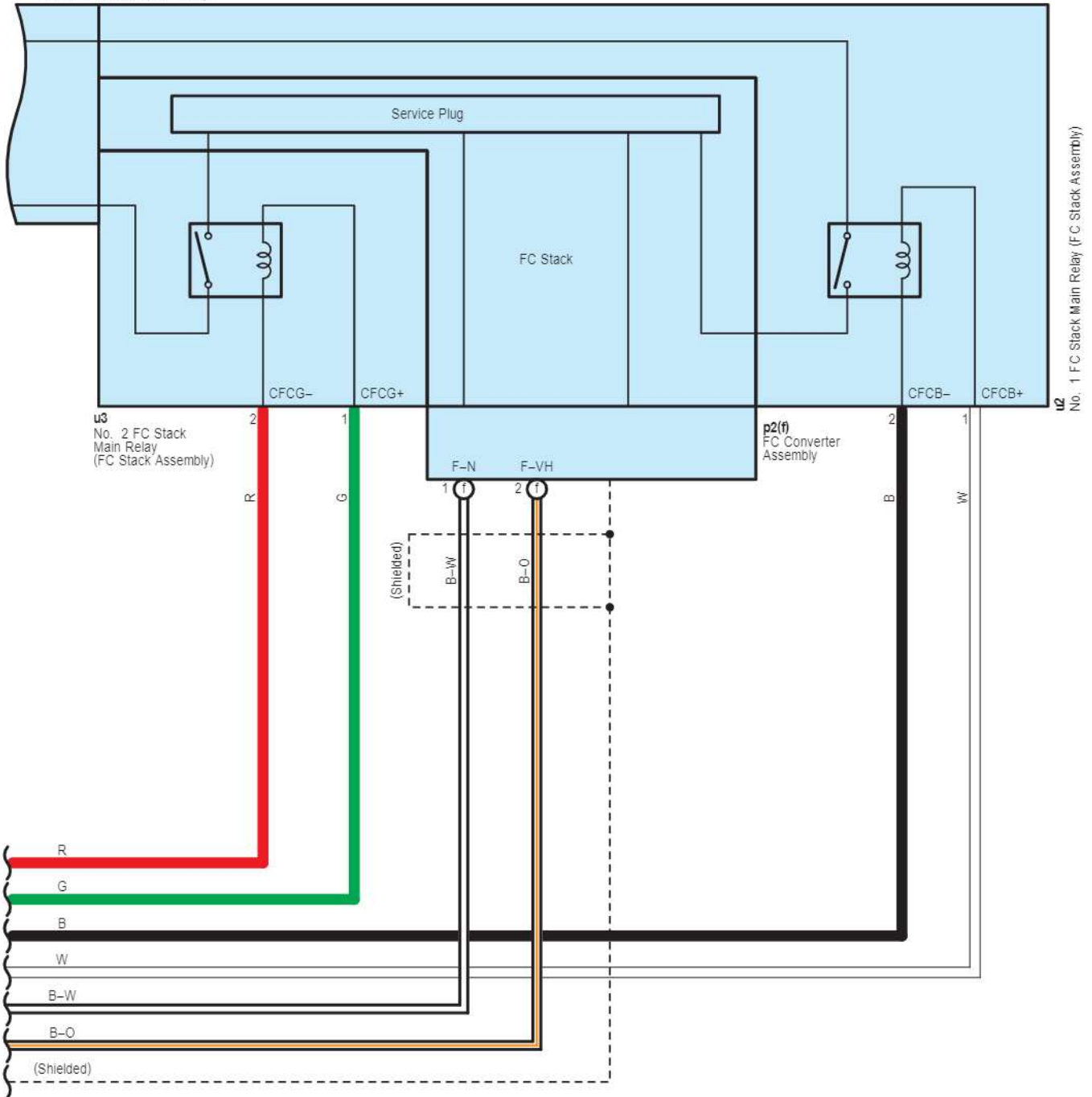

Front Wiper and Washer

G32
Windshield Wiper Relay Assembly

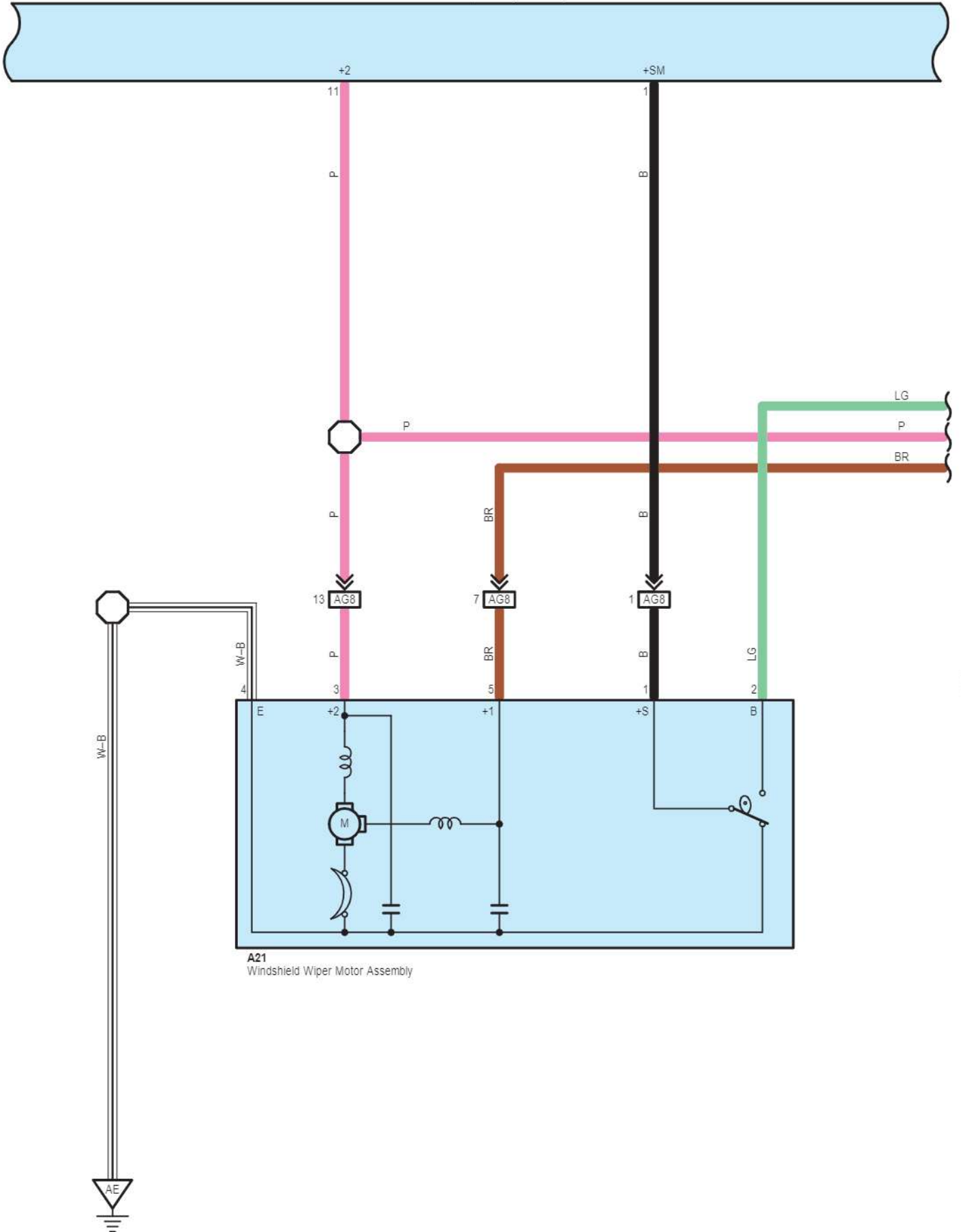

Ground Point (LHD)

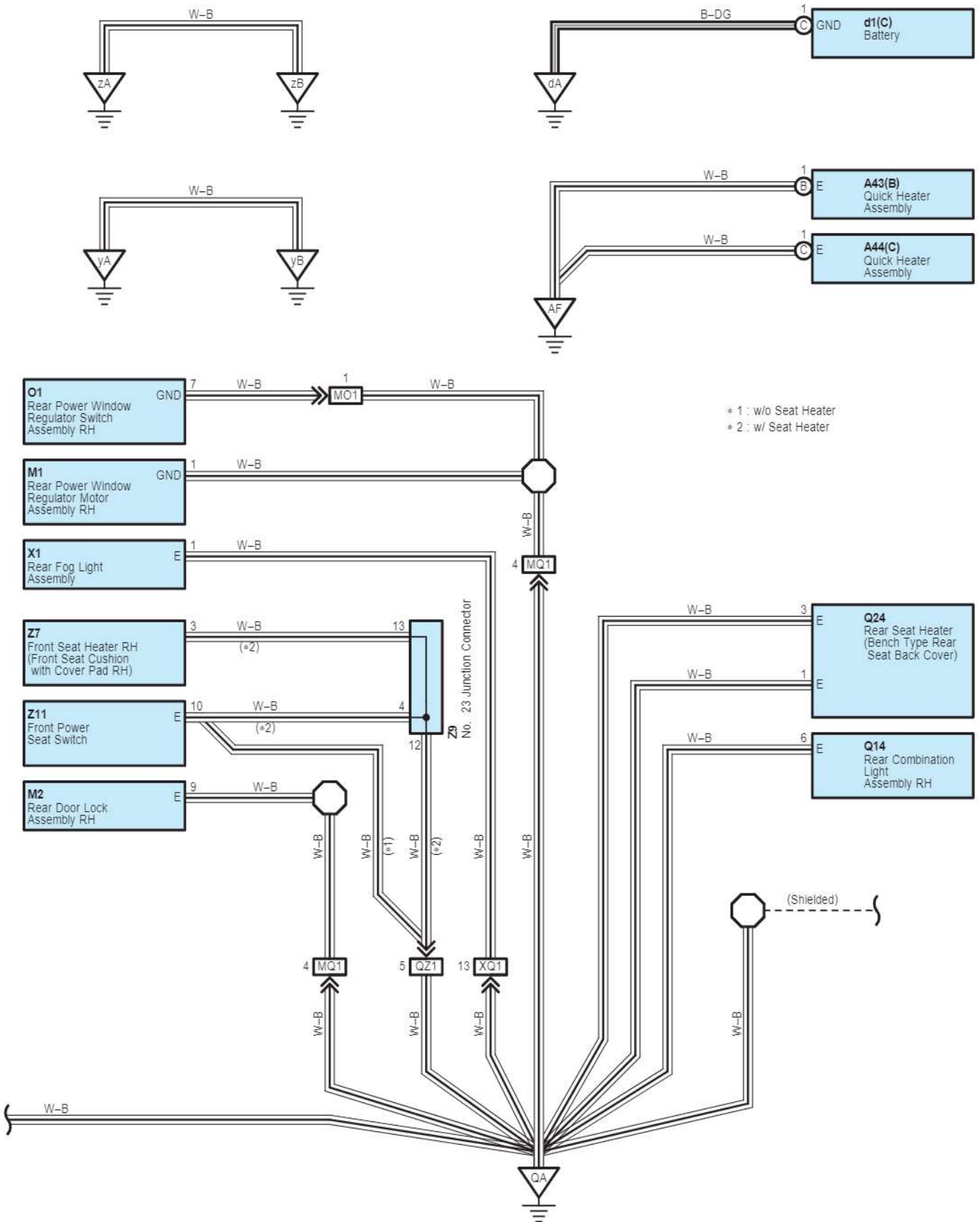

Ground Point (LHD)

PV1
White

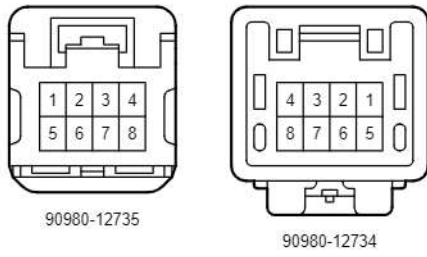

Pa1
White

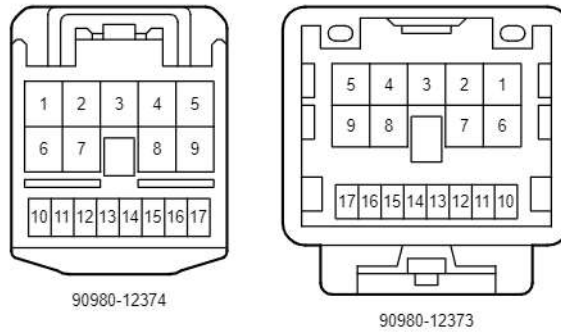

Pn1
White

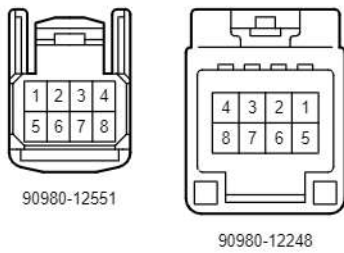

QZ1
White

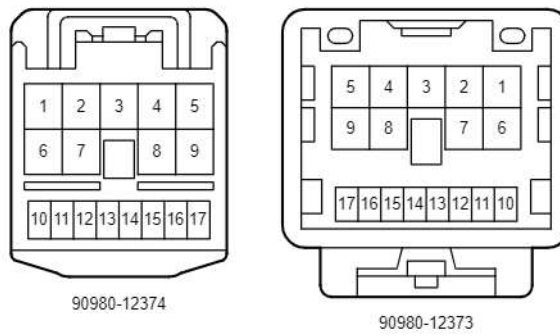

RP2
White

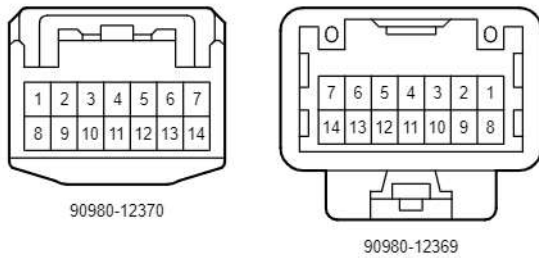

WG1
Gray

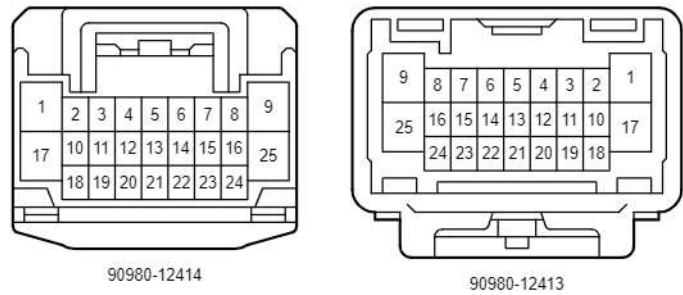

WG2
White

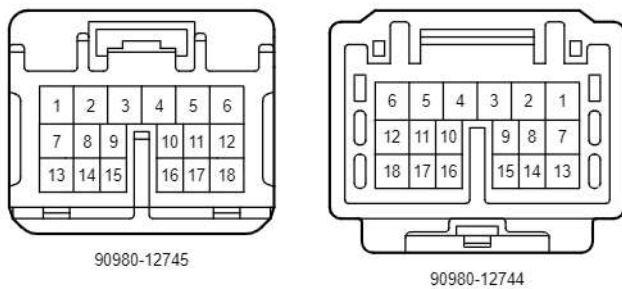

XQ1
Black

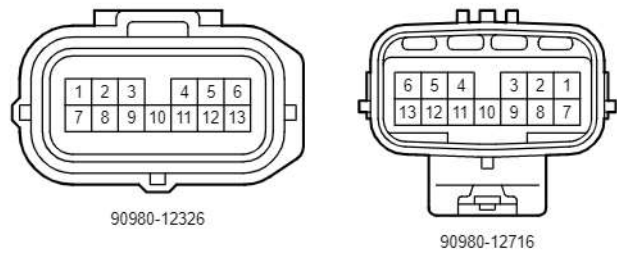

Ground Point (RHD)

* 1 : w/o Seat Heater
 * 2 : w/ Seat Heater

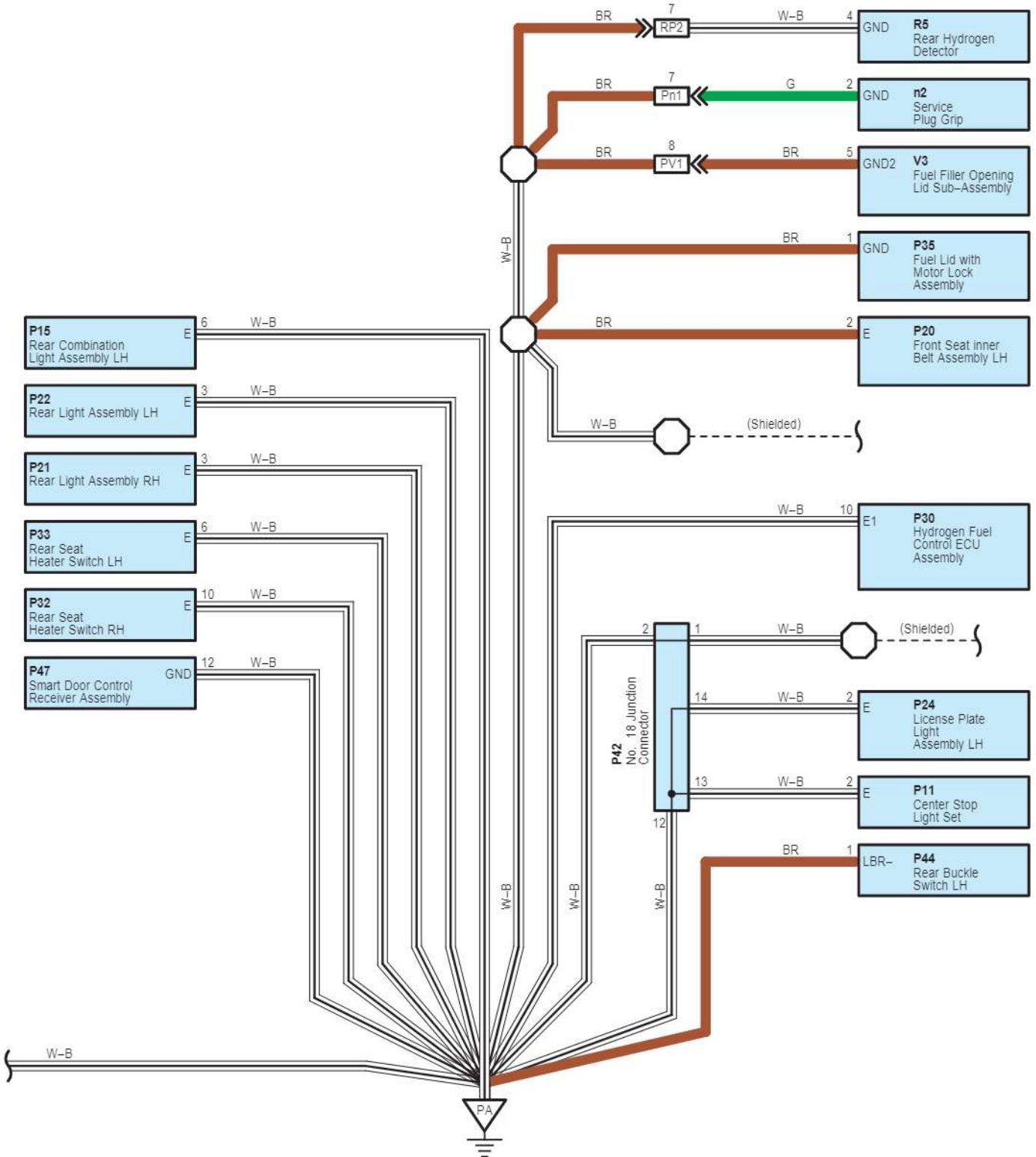

Ground Point (RHD)

GP1
White

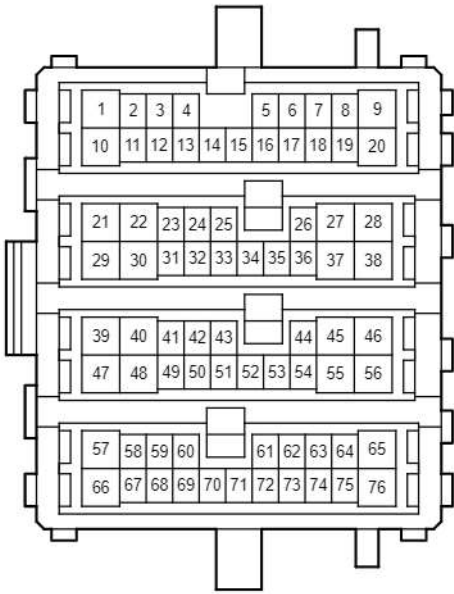

90980-12874

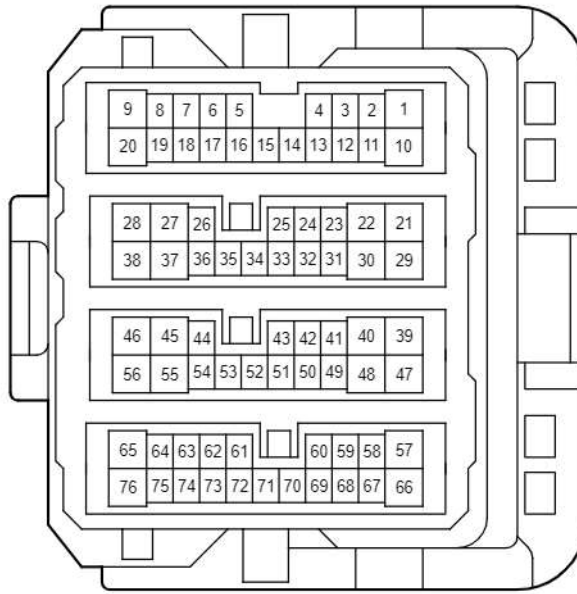

90980-12873

GQ1
White

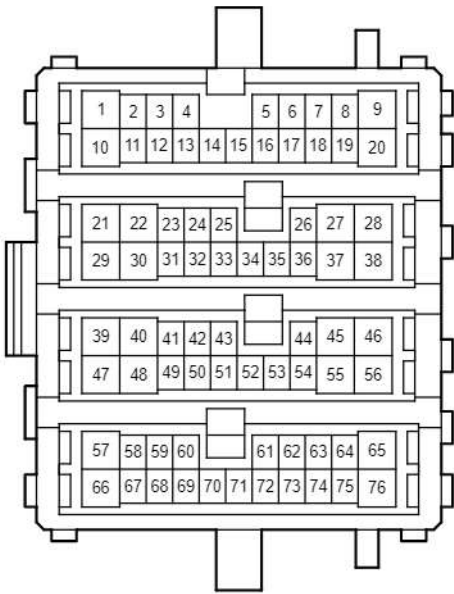

90980-12874

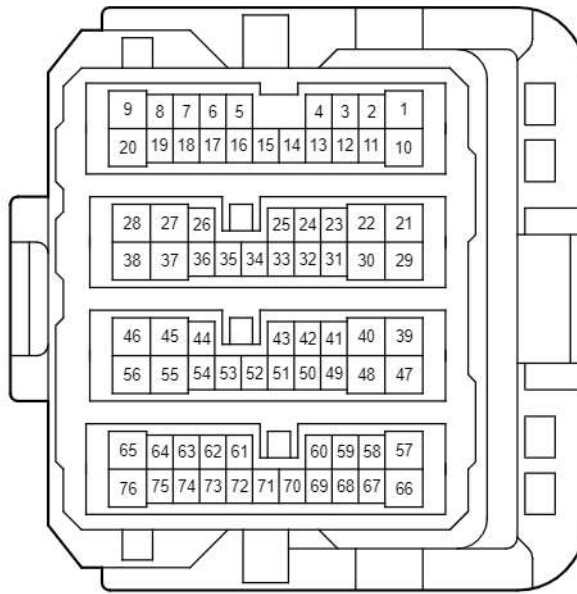

90980-12873

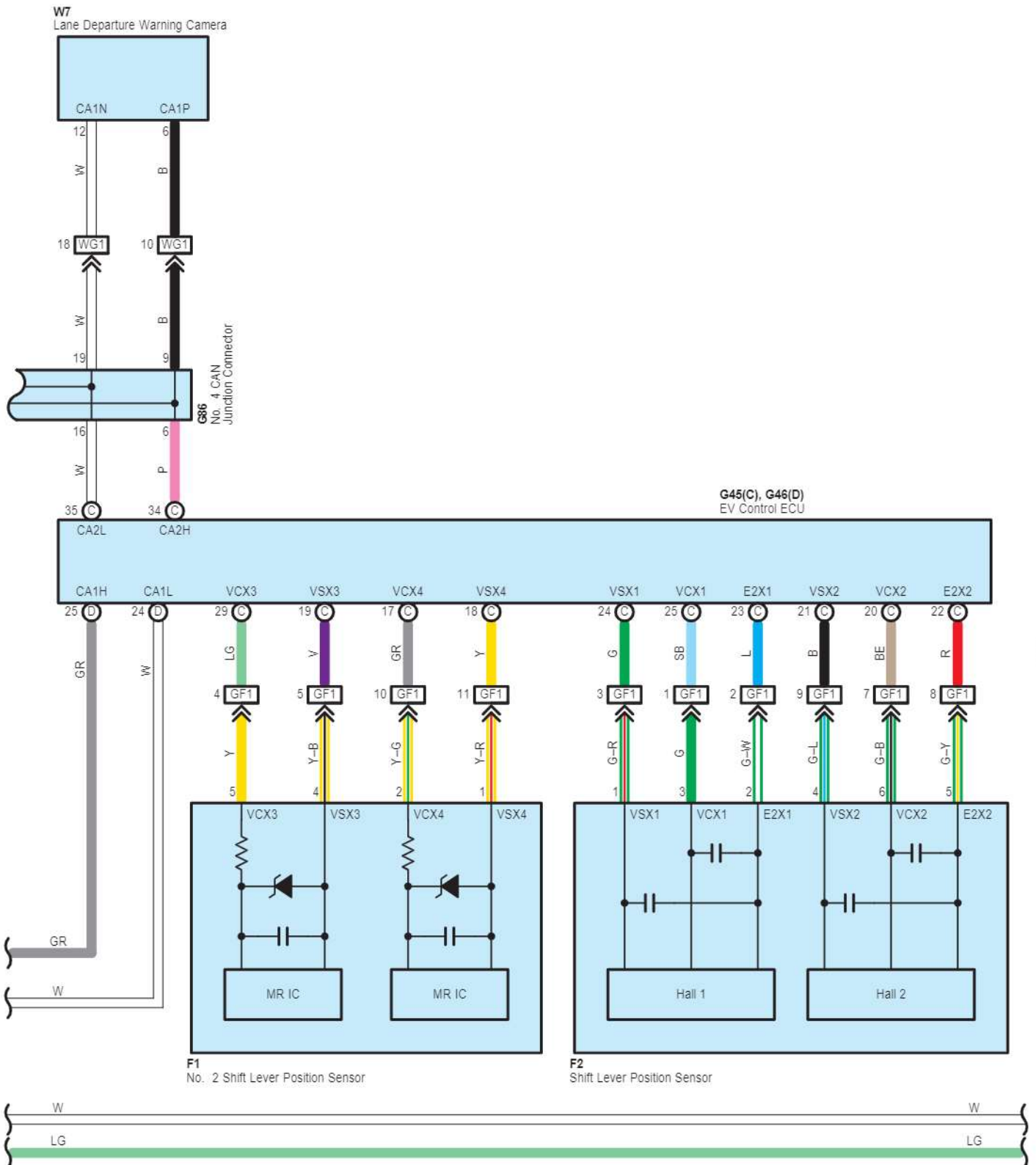

A27(A), G45(C), G46(D)
EV Control ECU

