

* 1 : Shielded
 * 2 : 2AZ-FE
 * 3 : 2ZR-FE

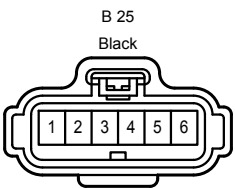

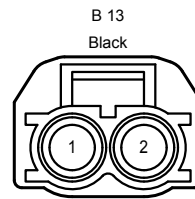

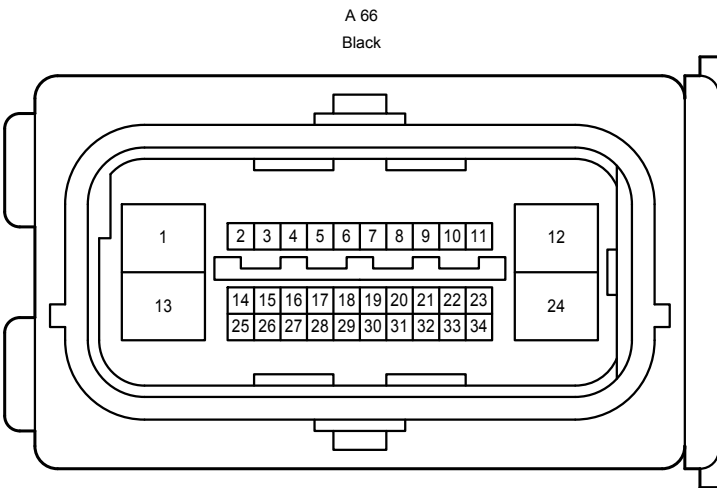
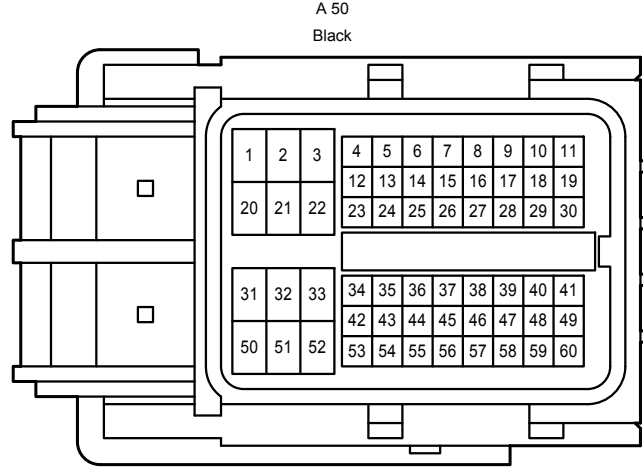
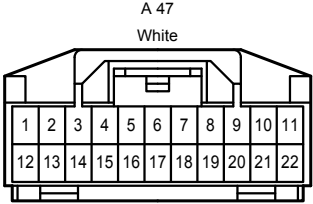
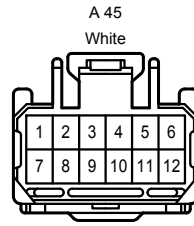
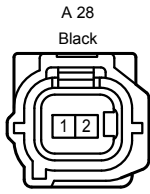
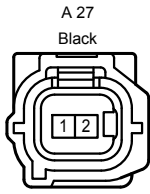
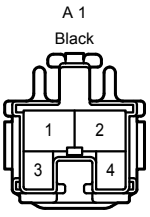
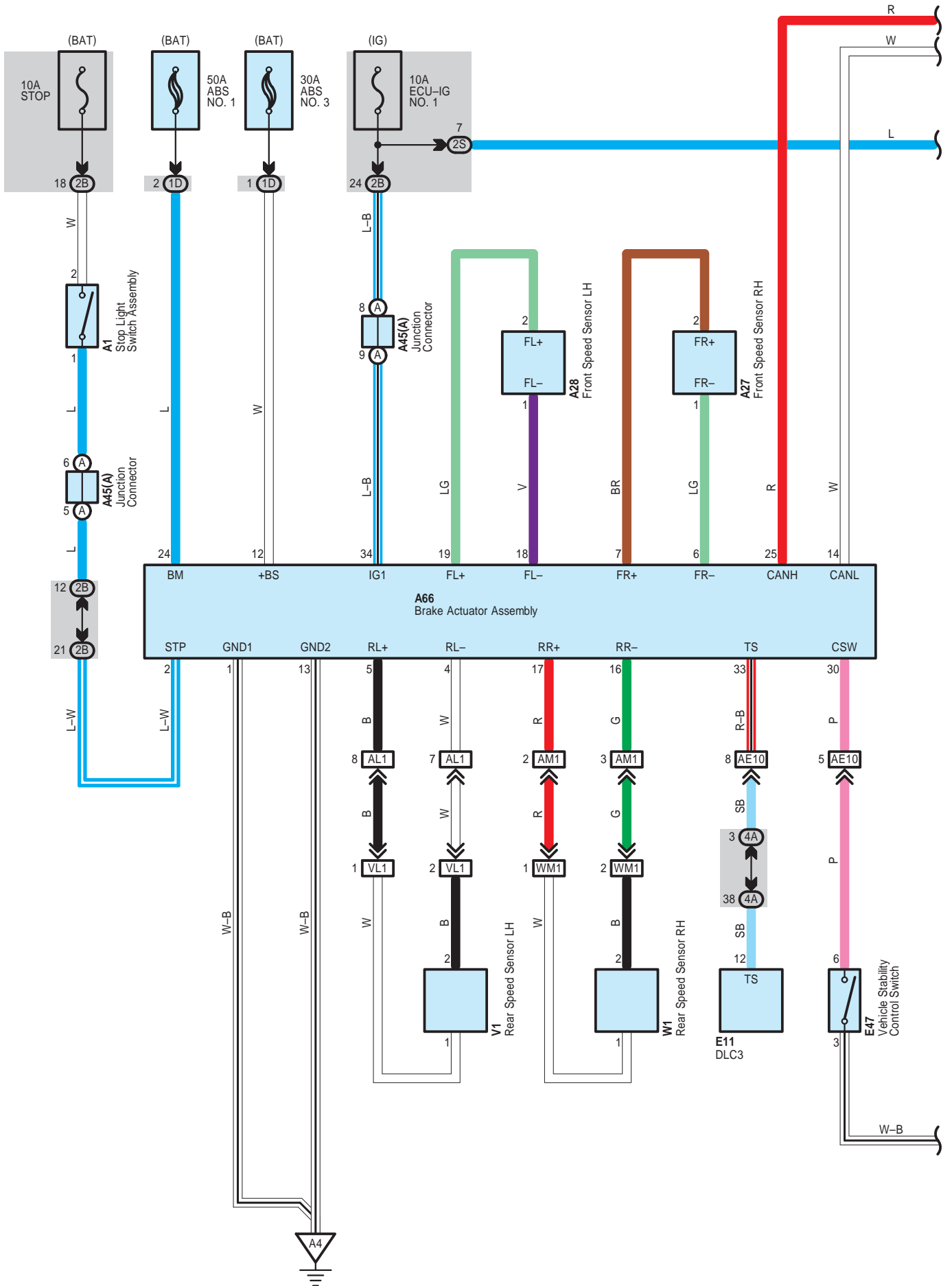
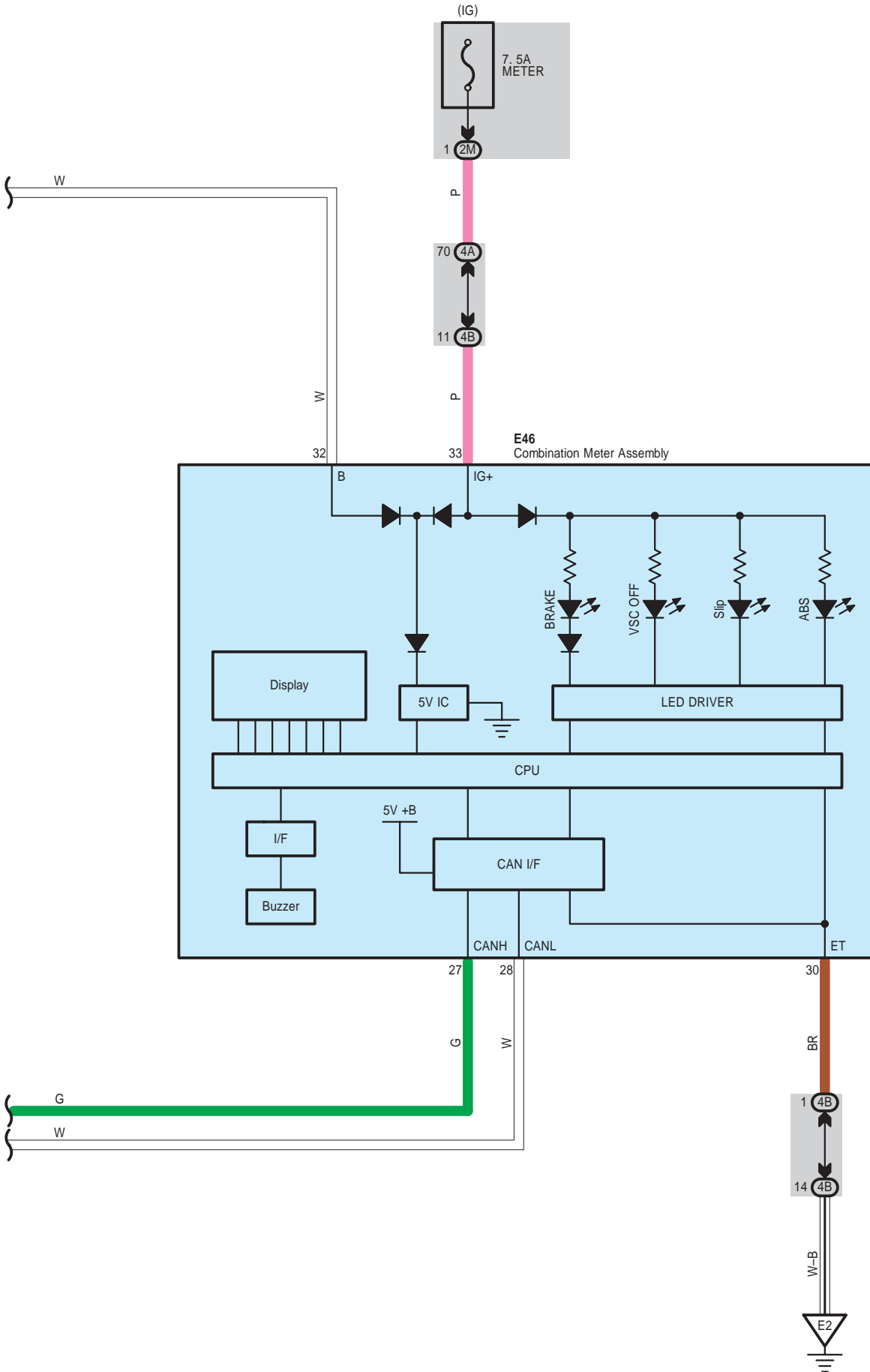

ABS <w/o VSC , Except TMC Made>

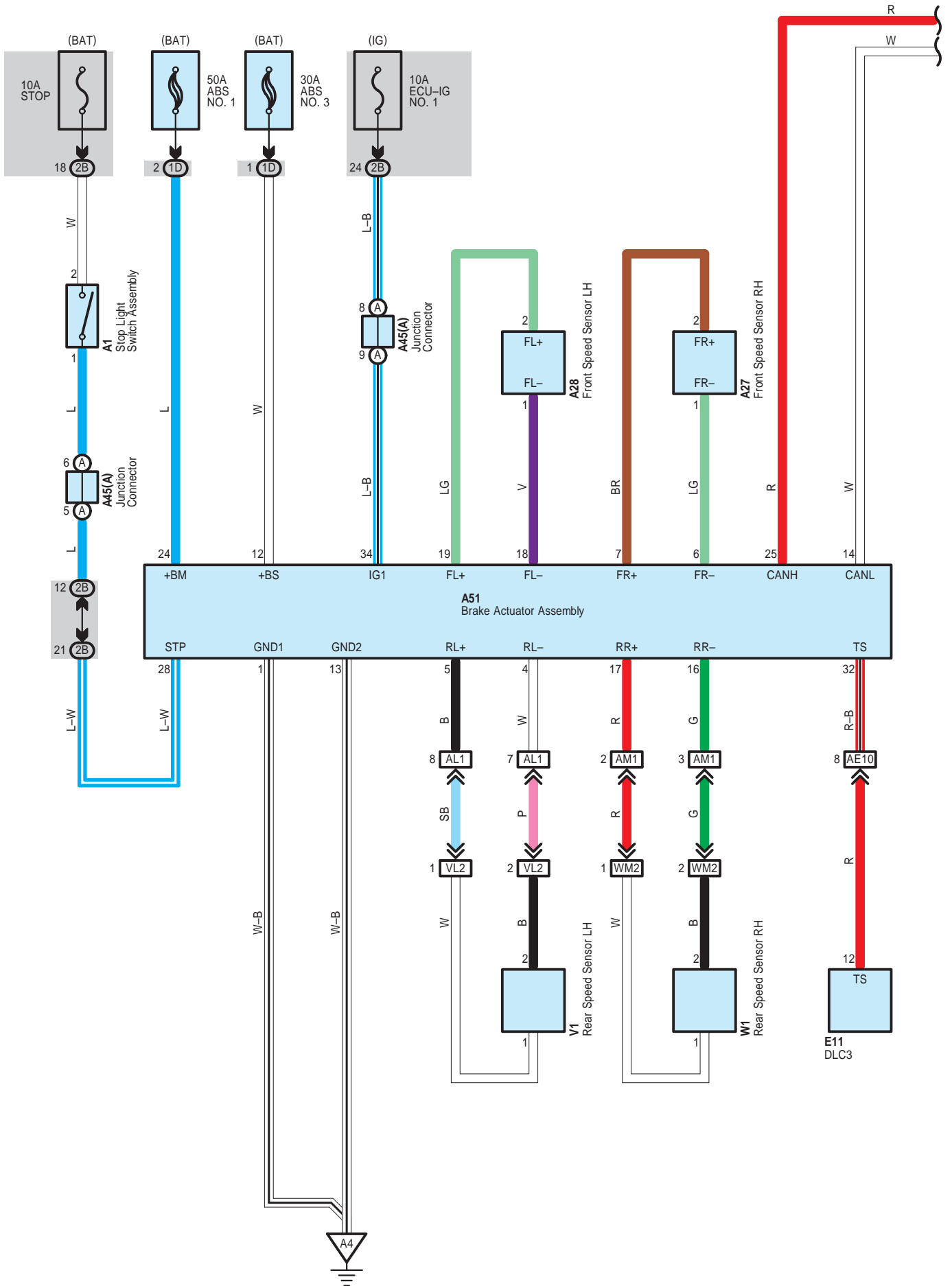

AE6
Gray

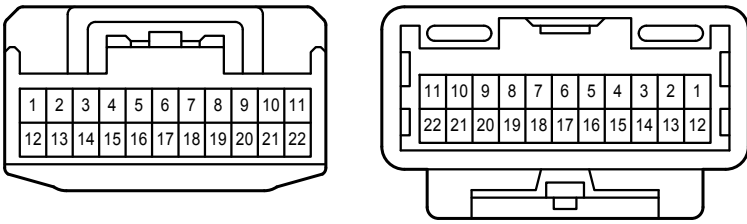

AE10
Gray

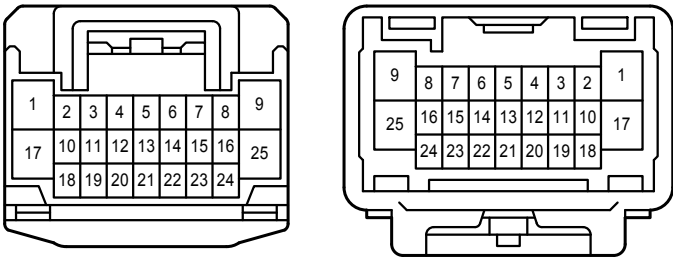

AL1
White

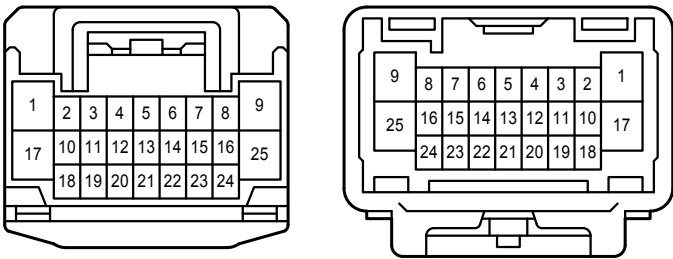

AM1
White

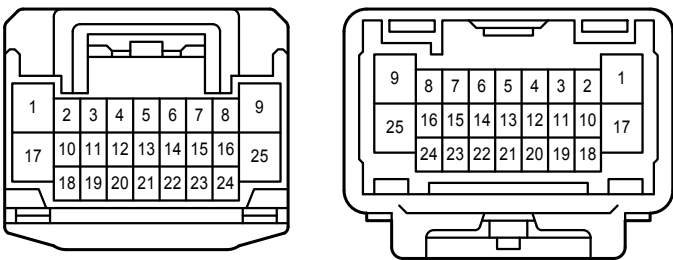

BA2
White

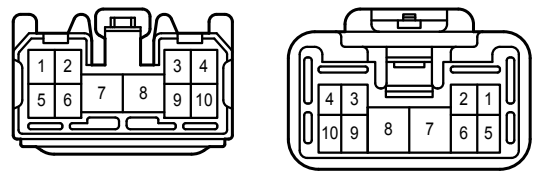

VL2

Black White

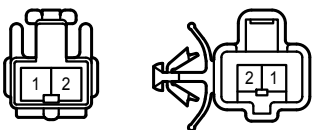

WM2

Black White

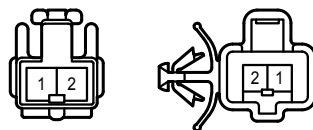

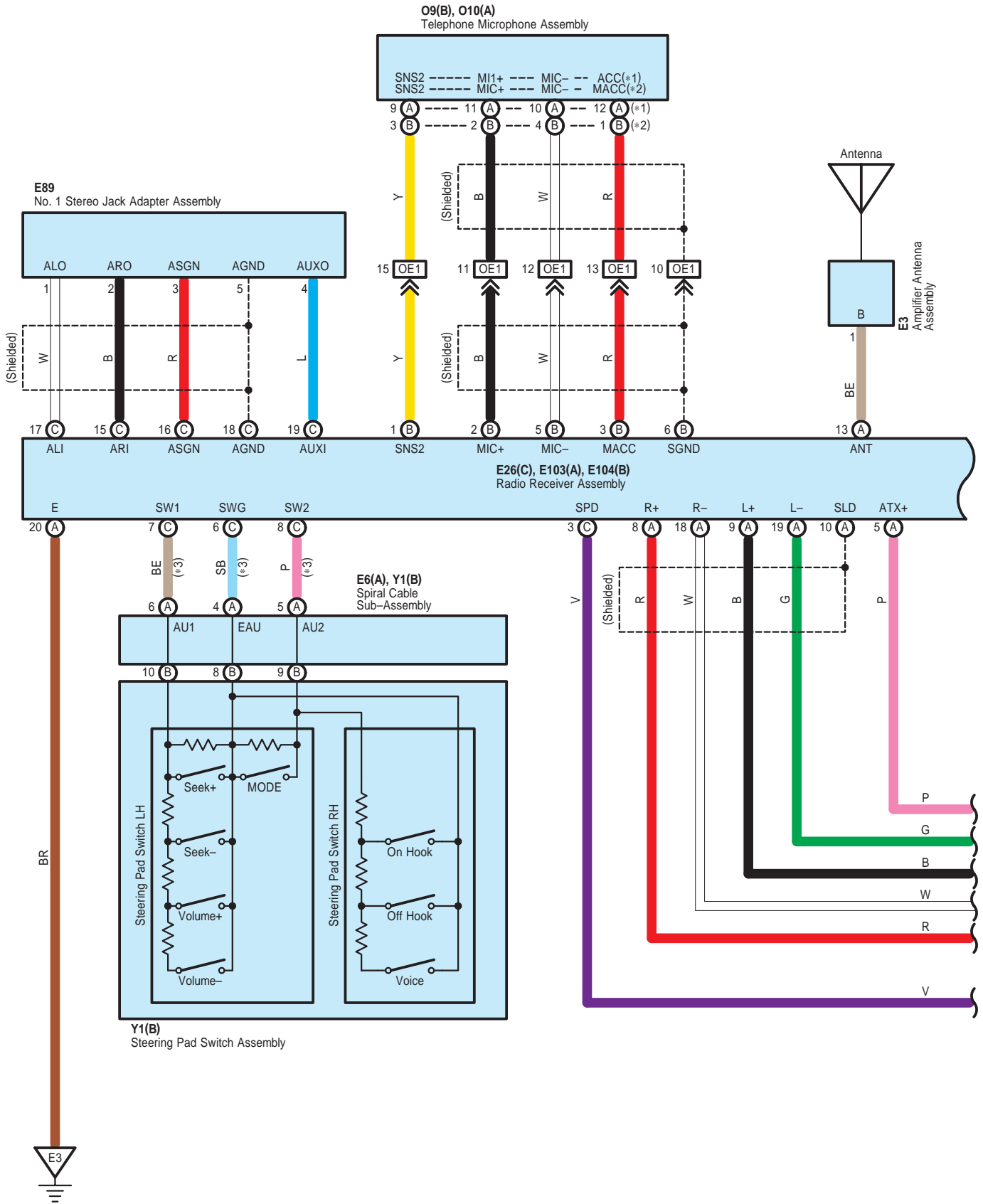

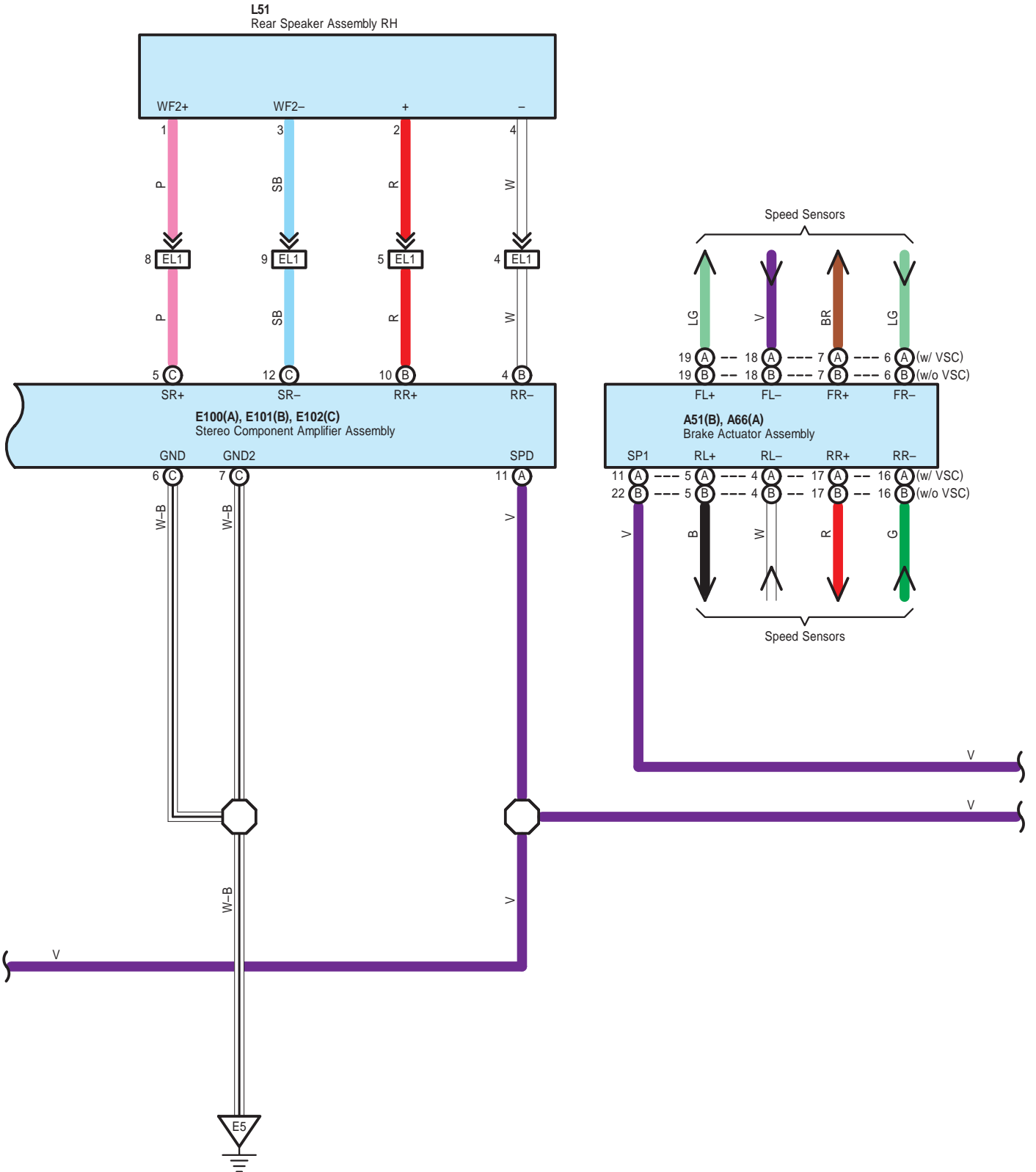

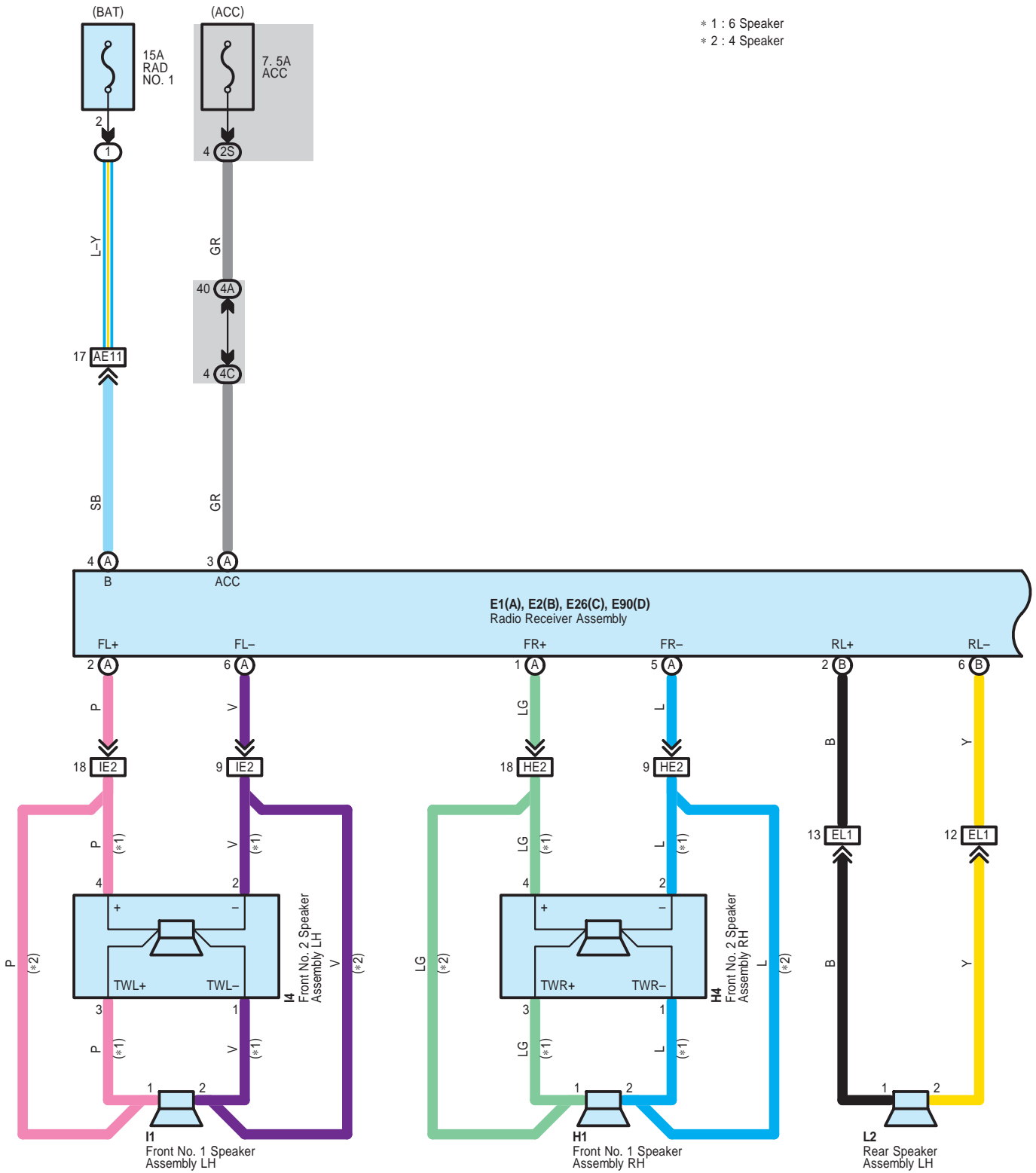

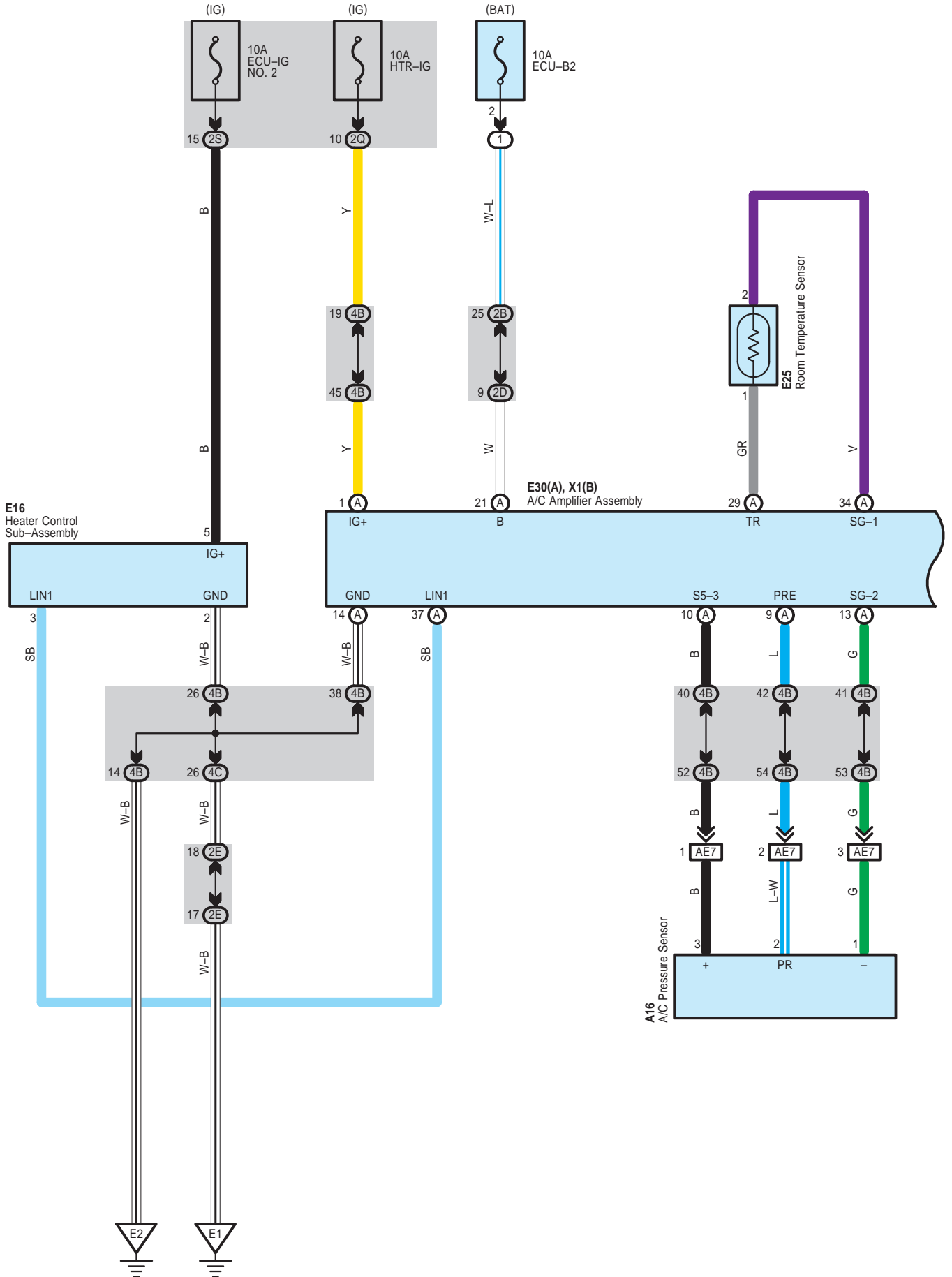

E 46
White

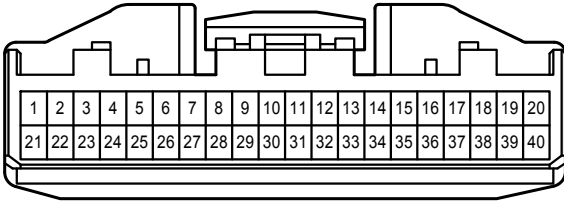

E 56
White

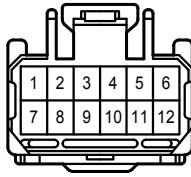

E 58
Gray

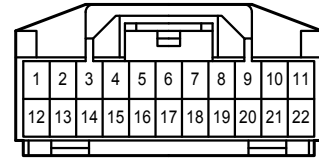

F 1
Black



X 1
White

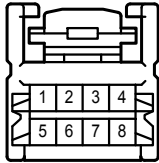

1D
White

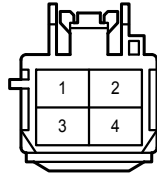

1I

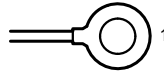

2B
White

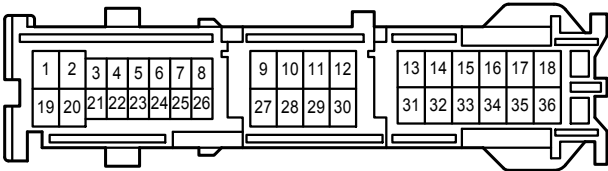

2D
White

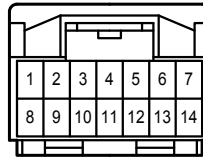

2E
White

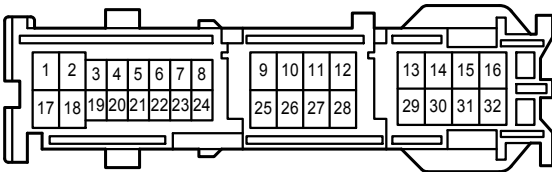

2F
White

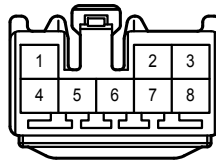

2H
White

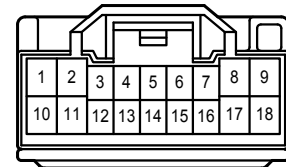

2L
White

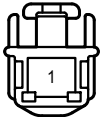

2M
White

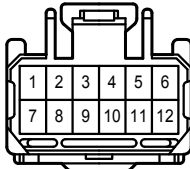

2Q
White

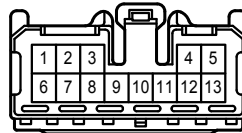

2S
White

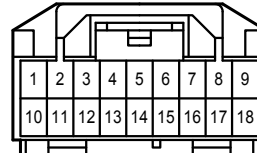

4A
White

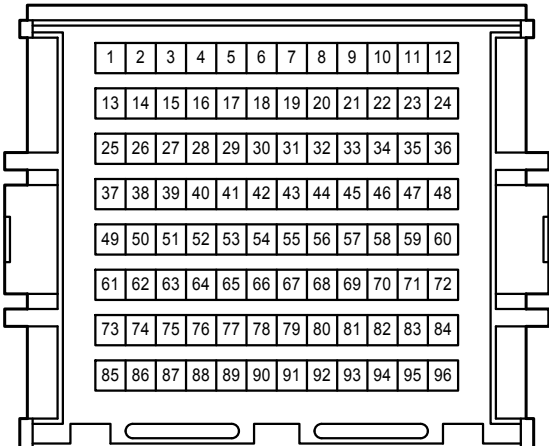

4B
White

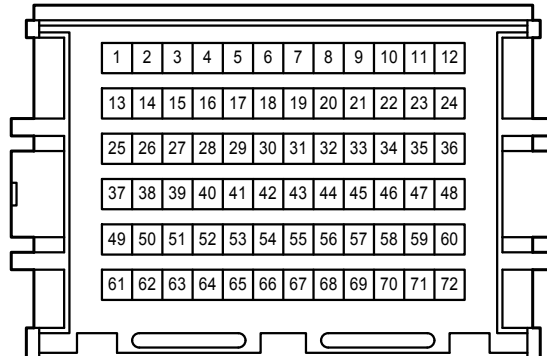

Back-Up Light <Except TMC Made>

- * 1 : 2AZ-FE
- * 2 : 2ZR-FE

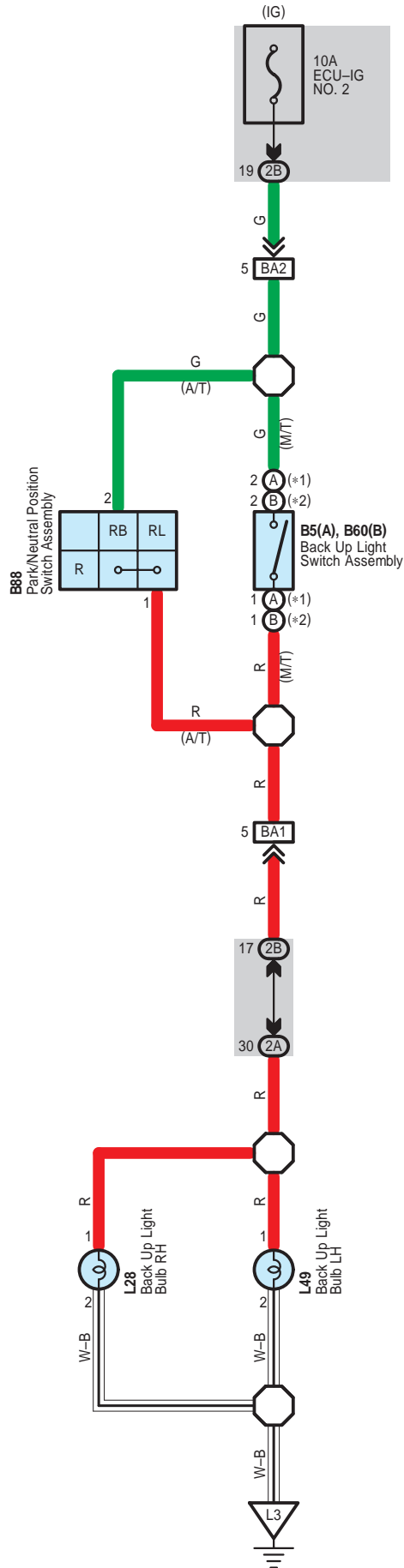

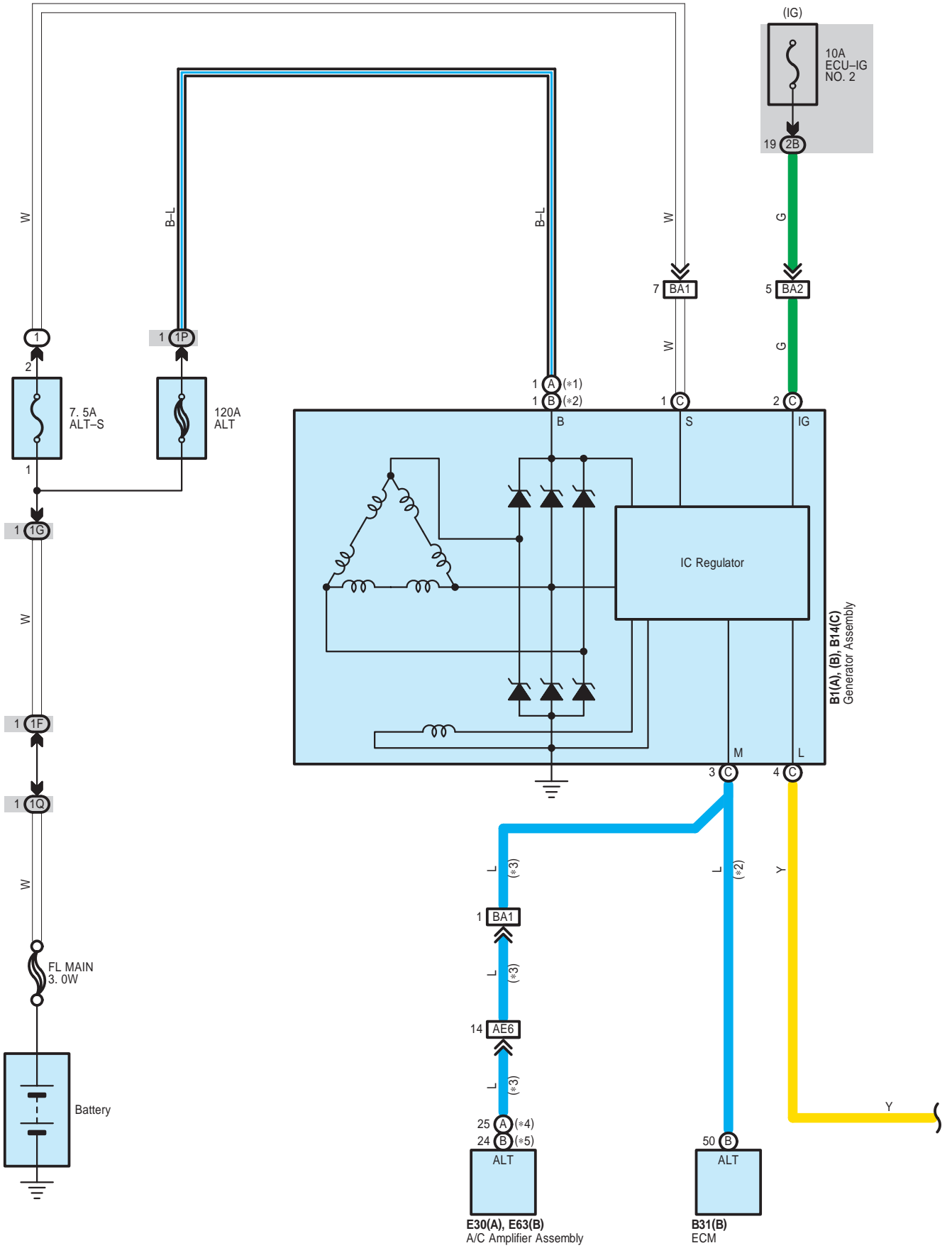

Cigarette Lighter <TMC Made>

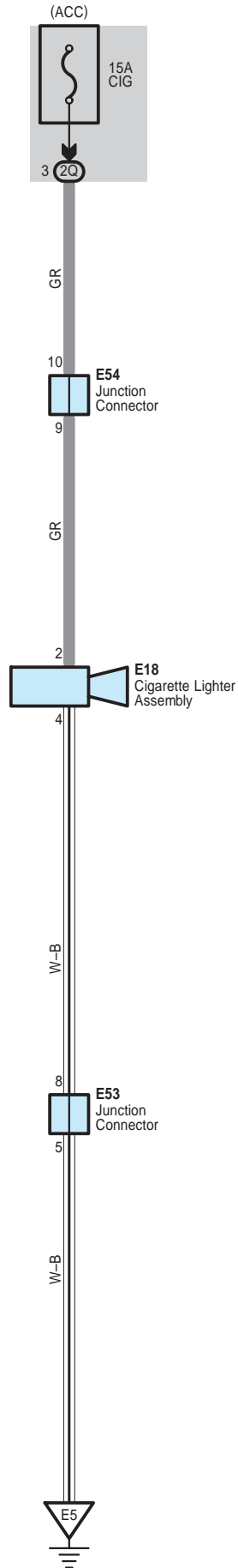

Combination Meter <TMC Made>

- * 3 : Optitron Meter
- * 4 : Except Optitron Meter

