

COROLLA ELECTRICAL WIRING DIAGRAM

(English)	Section No.	Page
INTRODUCTION	A ...	2
HOW TO USE THIS MANUAL	B ...	3
TROUBLESHOOTING	C ...	10
ABBREVIATIONS	D ...	15
GLOSSARY OF TERMS AND SYMBOLS	E ...	16
RELAY LOCATIONS	F ...	50
ELECTRICAL WIRING ROUTING	G ...	122
POWER SOURCE(Current Flow Chart)	H ...	166
SYSTEM CIRCUITS	I ...	180
GROUND POINTS.....	J ...	674
OVERALL ELECTRICAL WIRING DIAGRAM	K ...	694

SCHEMA DE CABLAGE ELECTRIQUE DE LA COROLLA

(Français)	N° de section	Page
INTRODUCTION	A ...	18
COMMENT UTILISER CE MANUEL.....	B ...	19
DEPANNAGE	C ...	26
ABREVIATIONS.....	D ...	31
GLOSSAIRE DES TERMES ET SYMBOLES	E ...	32
EMPLACEMENTS DES RELAIS	F ...	50
ACHEMINEMENT DES FILS ELECTRIQUES.....	G ...	122
SOURCE D'ALIMENTATION(Schéma de Courant)	H ...	166
CIRCUITS DU SYSTEME	I ...	182
POINTS DE MISE A LA TERRE	J ...	674
SCHEMA GENERAL DE CABLAGE ELECTRIQUE	K ...	696

COROLLA DIAGRAMA DEL CABLEADO ELECTRICO

(Español)	Sección N°	Página
INTRODUCCION	A ...	34
COMO UTILIZAR ESTE MANUAL.....	B ...	35
LOCALIZACION DE AVERIAS	C ...	42
ABREVIATURAS	D ...	47
GLOSARIO DE TERMINOS Y SIMBOLOS	E ...	48
UBICACION DE LOS RELES	F ...	50
RECORRIDO DE LOS CABLES ELECTRICOS.....	G ...	122
FUENTE DE ALIMENTACION(Cuadro de flujo de corriente) ..	H ...	166
CIRCUITOS DE SISTEMAS	I ...	184
PUNTOS DE CONEXION A MASA.....	J ...	674
DIAGRAMA DE CONEXIONES ELECTRICAS GENERAL	K ...	698

* The system shown here is an EXAMPLE ONLY. It is different to the actual circuit shown in the SYSTEM CIRCUITS SECTION.

POWER WINDOW

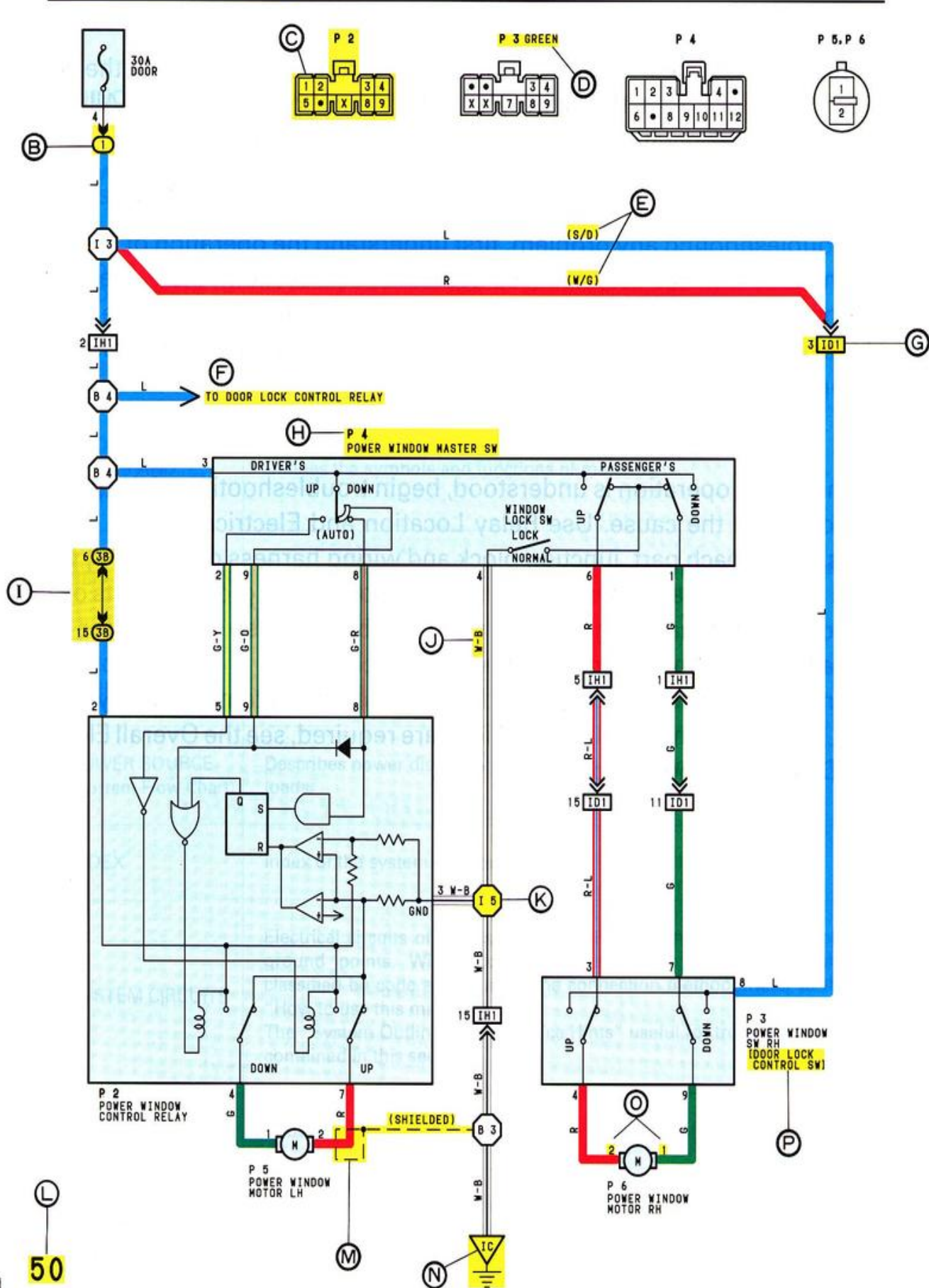

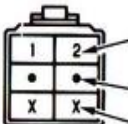
- (A): System Title
- (B): Indicates a Relay Block. No shading is used and only the Relay Block No. is shown to distinguish it from the J/B.
Example: (1) Indicates Relay Block No. 1.
- (C): Indicates the connector to be connected to a part (the numeral indicates the pin No.)
Explanation of pin use.

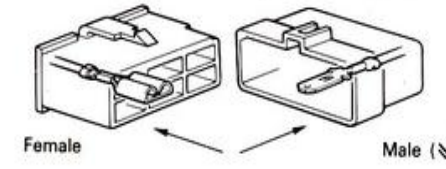
 - Pins used in the system circuit.
 - Occupied positions, but not applicable to the system circuit.
 - Unoccupied positions.
- (D): Connector Color
Connectors not indicated are milky white in color.
- (E): () is used to indicate different wiring and connector, etc. when the vehicle model, engine type, or specification is different.
- (F): Indicates related system.
- (G): Indicates the wiring harness and wiring harness connector. The wiring harness with male terminal is shown with arrows (↘). Outside numerals are pin numbers.

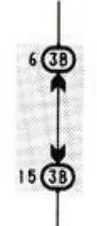

- (H): Represents a part (all parts are shown in sky blue). The code is the same as the code used in parts position.
- (I): Junction Block (The number in the circle is the J/B No. and the connector code is shown beside it). Junction Blocks are shaded to clearly separate them from other parts.
Example:

3B indicates that it is inside Junction Block No. 3.

- (J): Indicates the wiring color.
Wire colors are indicated by an alphabetical code.

B = Black	L = Blue	R = Red
BR = Brown	LG = Light Green	V = Violet
G = Green	O = Orange	W = White
GR = Gray	P = Pink	Y = Yellow

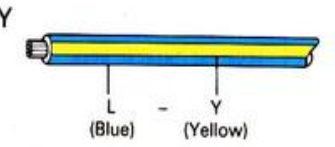

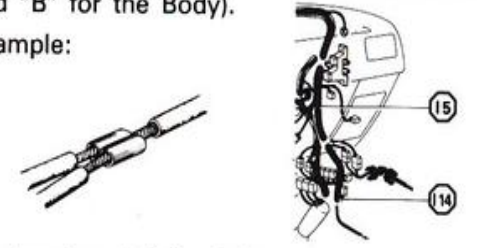
- (K): Indicates a wiring Splice Point (Codes are "E" for the Engine Room, "I" for the Instrument Panel, and "B" for the Body).
Example:

The Location of Splice Point I 5 is indicated by the shaded section.

- (L): Page No.
- (M): Indicates a shielded cable.



- (N): Indicates a ground point.
The first letter of the code for each ground point(s) indicates the component's location, e.g. "E" for the Engine Compartment, "I" for the Instrument Panel and Surrounding area, and "B" for the Body and Surrounding area.

- (O): Indicates the pin number of the connector. The numbering system is different for female and male connectors.
Example: Numbered in order from upper left to lower right

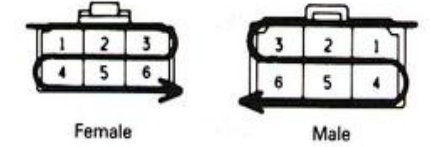

- (P): When 2 parts both use one connector in common, the parts connector name used in the wire routing section is shown in square brackets [].

○: Engine Room J/B Engine Compartment Left (See Page 50)

- *1:7A-FE, 5A-FE, 4A-FE, 4E-FE
- *2:2C-E
- *3:HEAD(RH) (w/o Daytime Running Light) or HEAD (RH-UPR) (w/ Daytime Running Light)
- *4:EFI(*1) or F-HTR(*2)
- *5:HEAD(LH) (w/o Daytime Running Light) or HEAD (LH-UPR) (w/ Daytime Running Light)

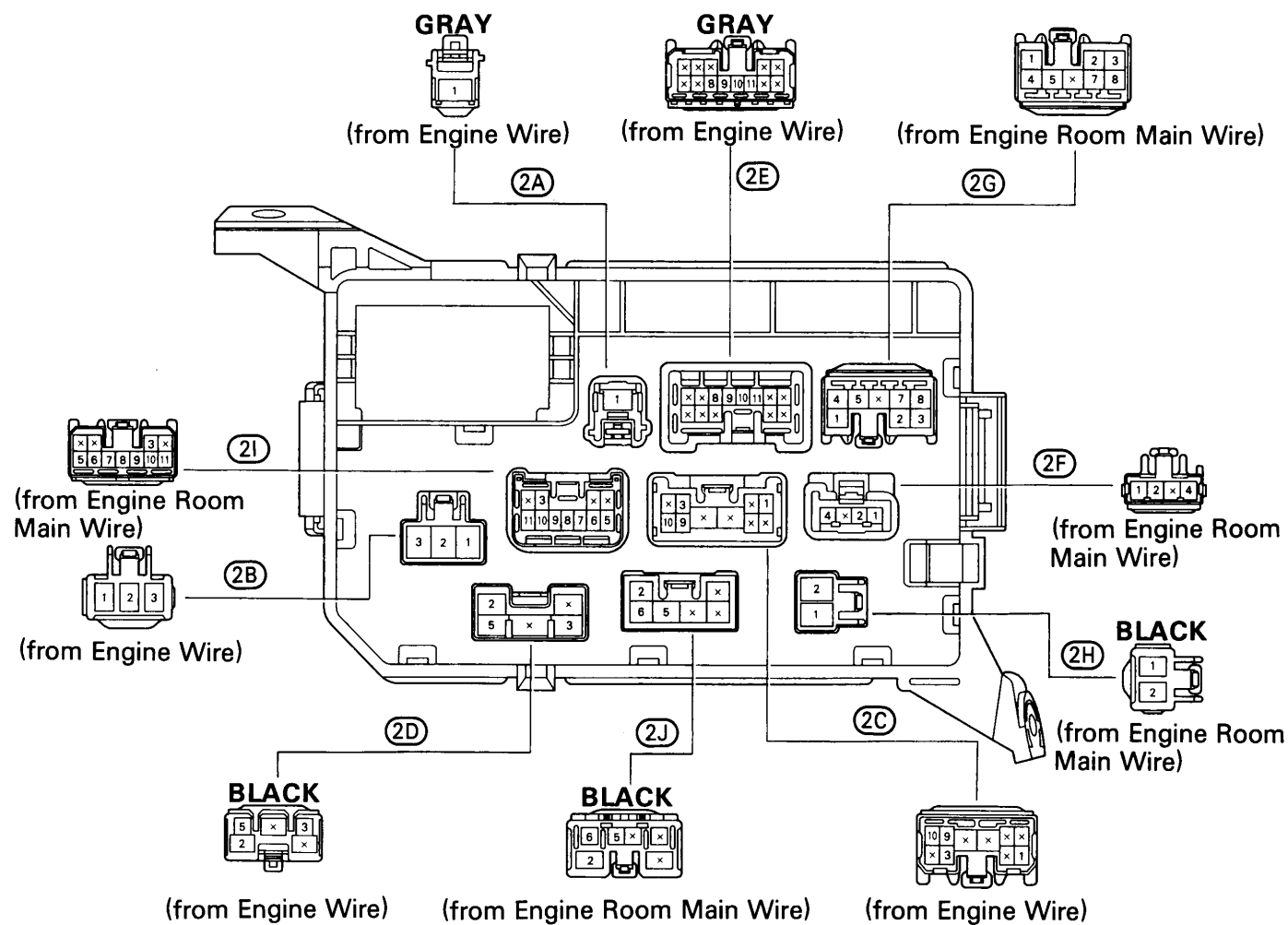
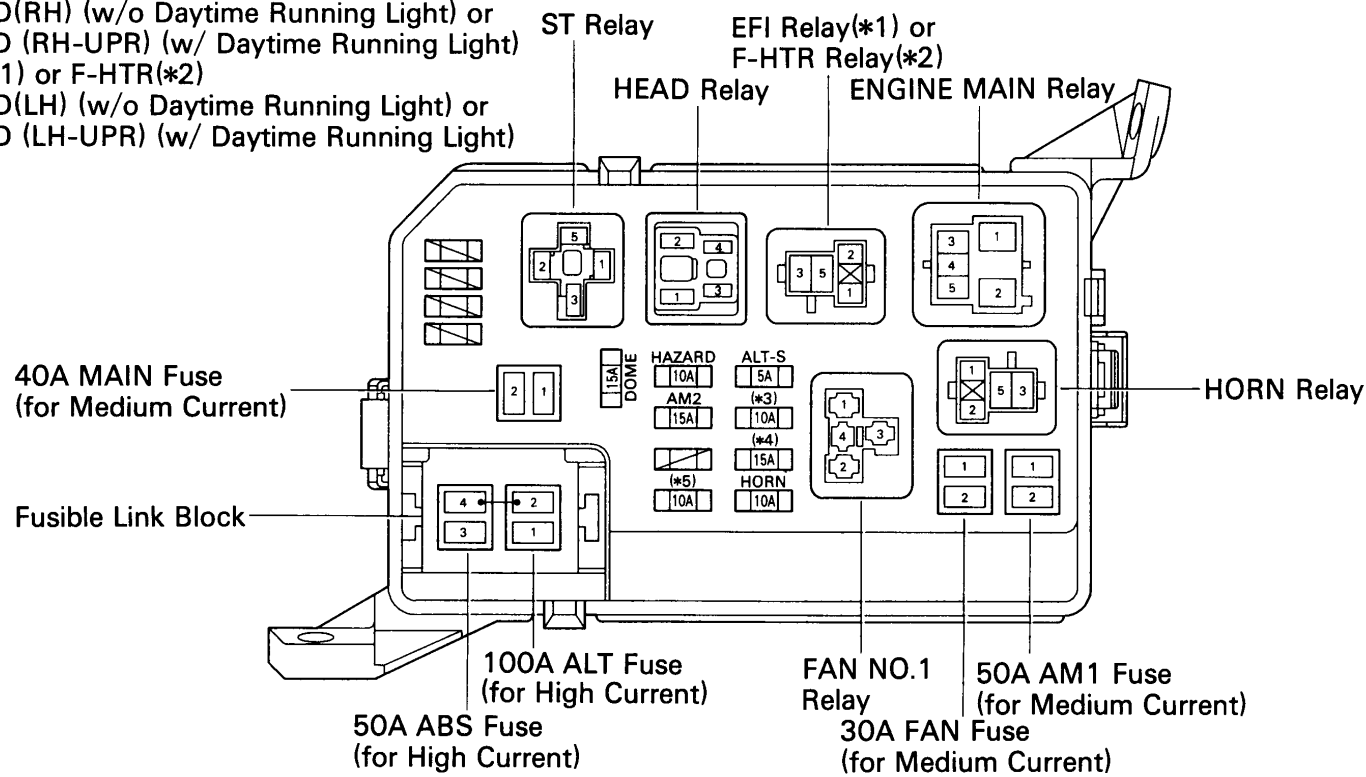

[Engine Room J/B Inner Circuit]

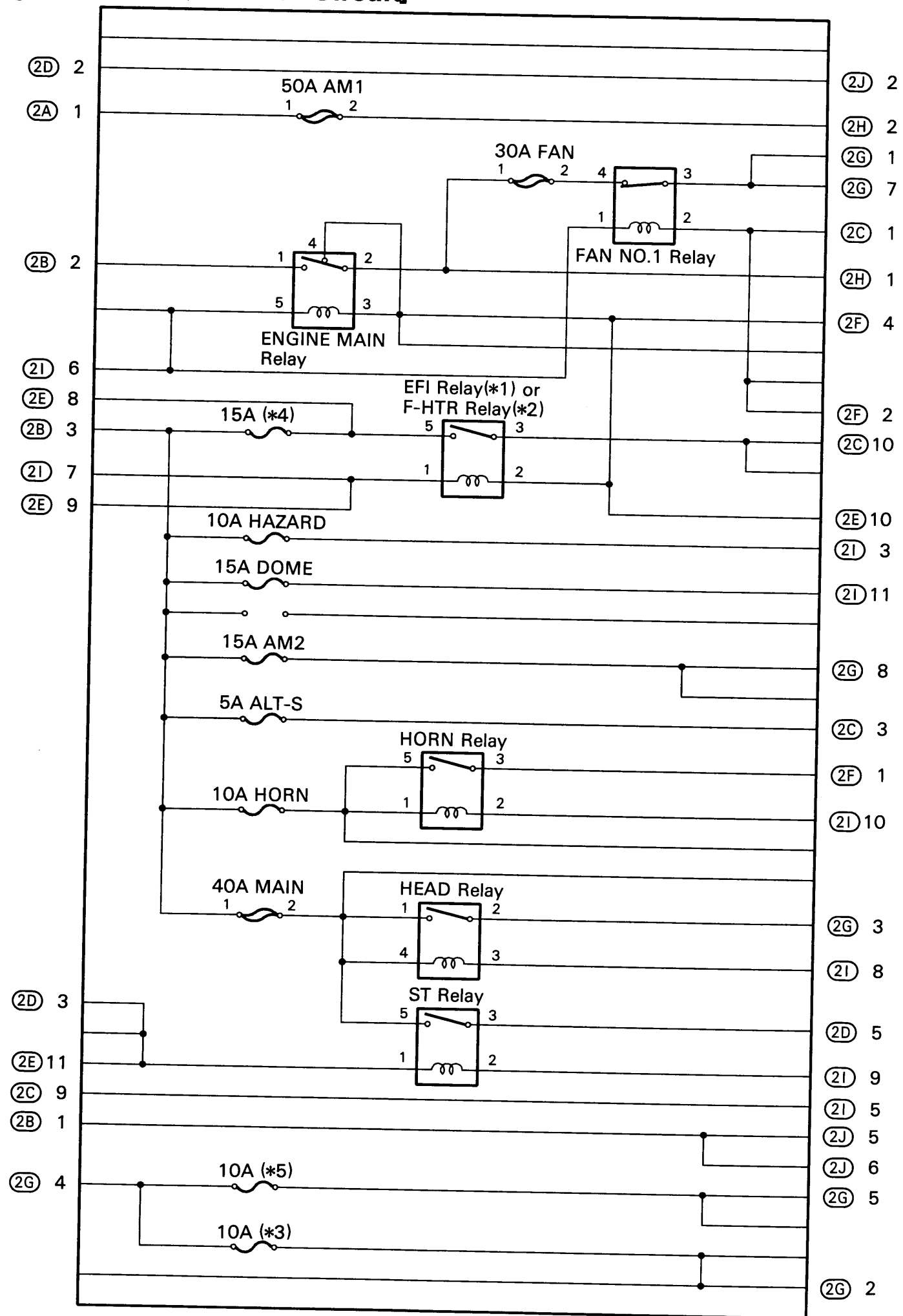

□ : Location of Connector Joining Wire Harness and Wire Harness

[LHD]

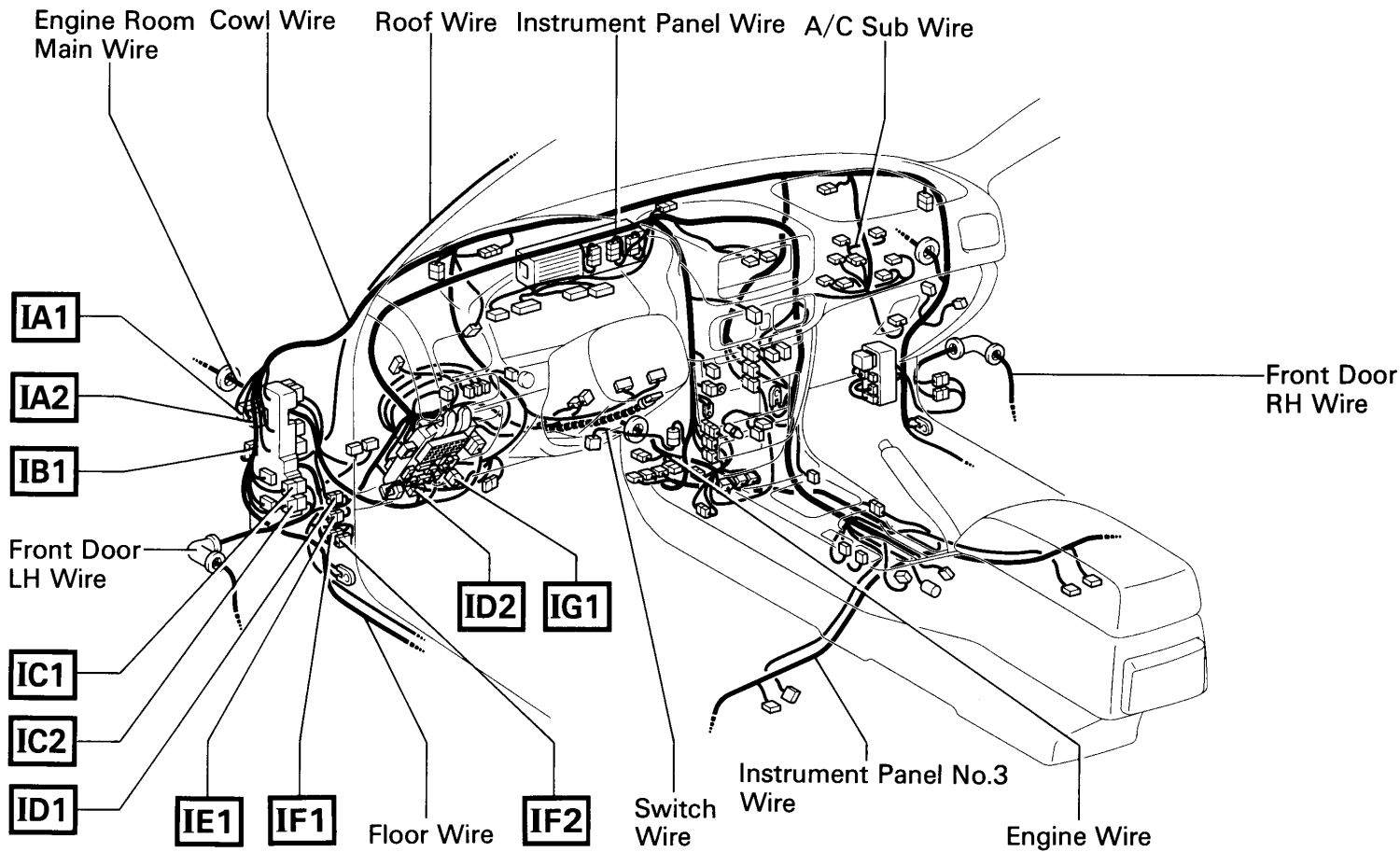

▽ : Location of Ground Points

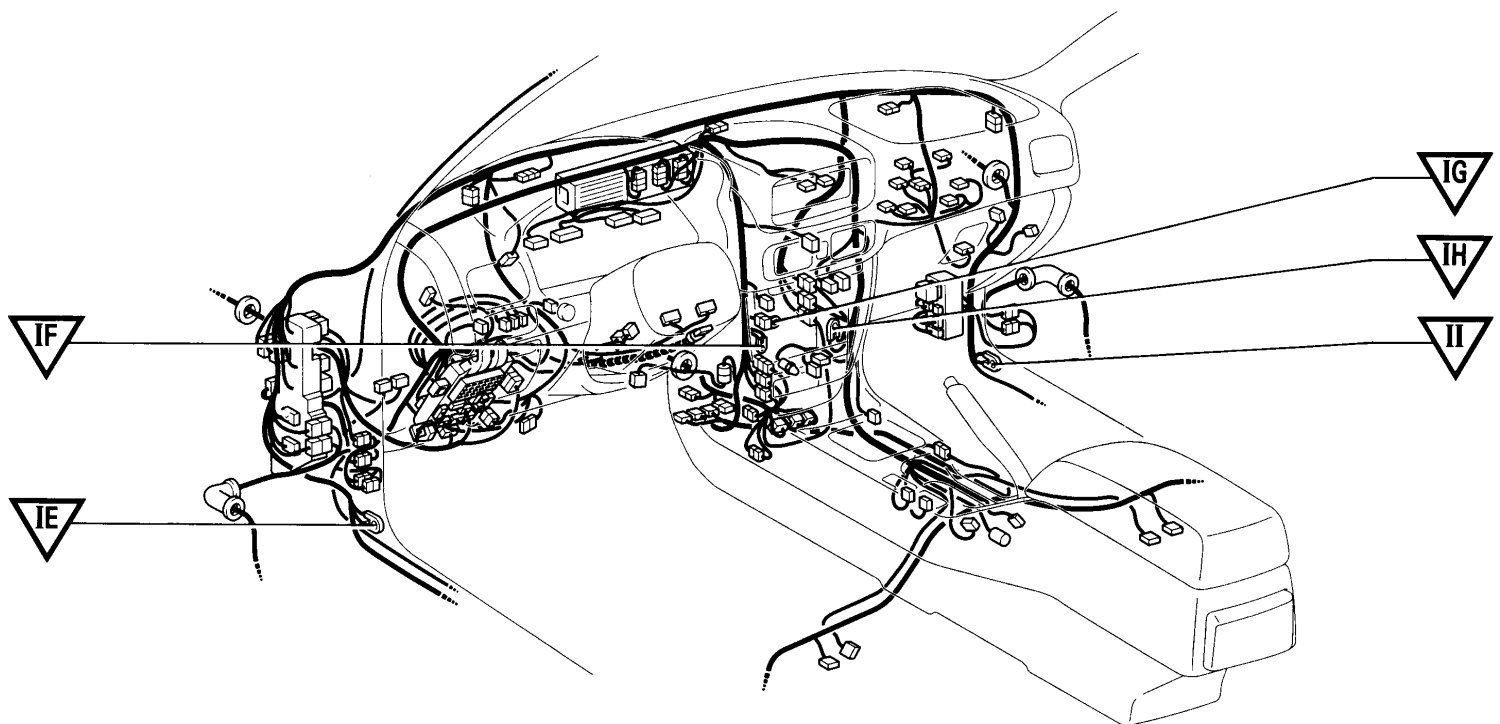

Connector Joining Wire Harness and Wire Harness

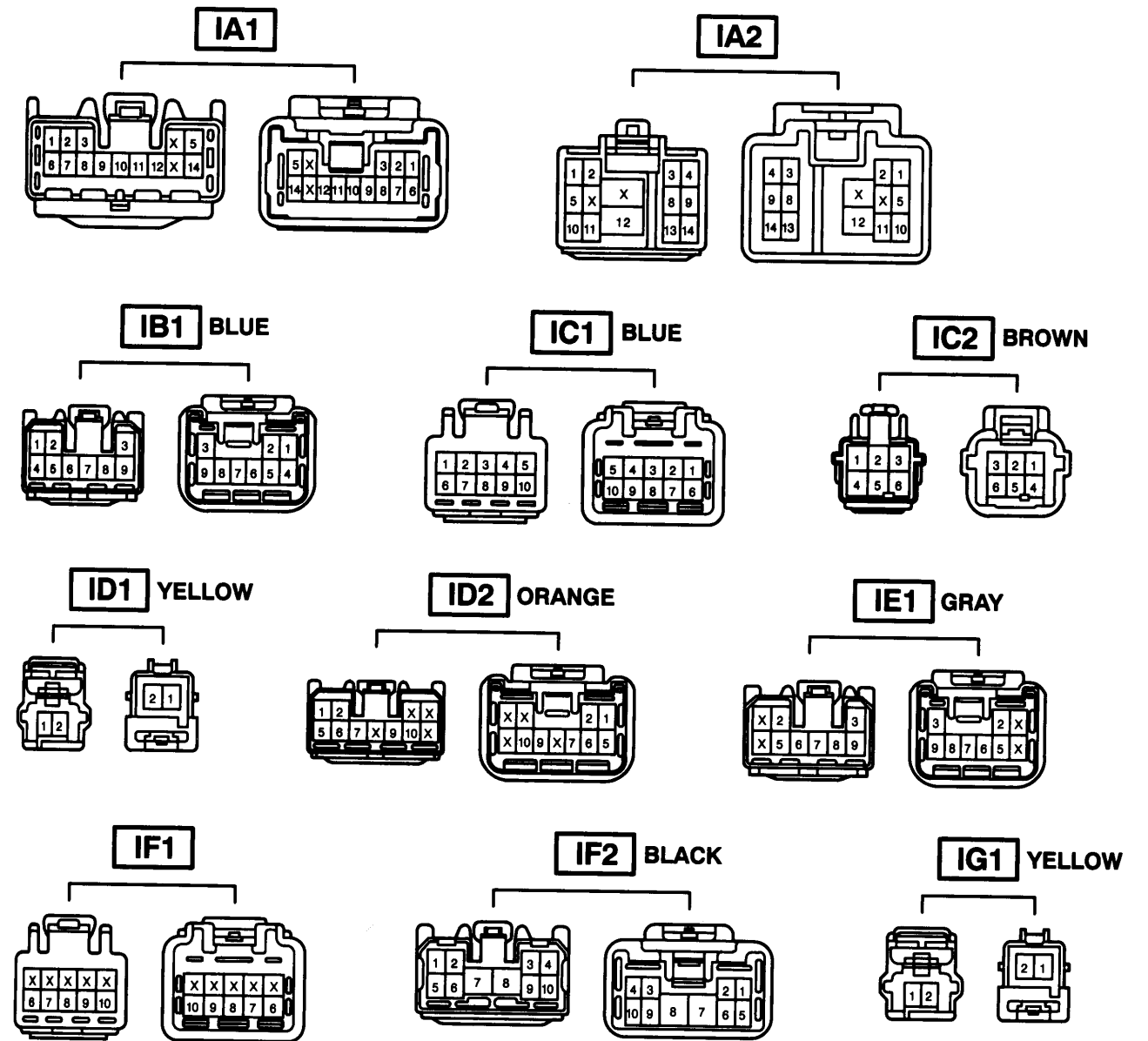

Code	Joining Wire Harness and Wire Harness (Connector Location)
IA1	Engine Room Main Wire and Cowl Wire (Near the Driver Side R/B)
IA2	Engine Room Main Wire and Cowl Wire (Near the Driver Side R/B)
IB1	Floor Wire and Cowl Wire (Near the Driver Side R/B)
IC1	Front Door LH Wire and Cowl Wire (Near the Driver Side R/B)
IC2	Front Door LH Wire and Cowl Wire (Near the Driver Side R/B)
ID1	Engine Room Main Wire and Instrument Panel Wire (Lower Finish Panel)
ID2	Engine Room Main Wire and Instrument Panel Wire (Lower Finish Panel)
IE1	Front Door LH Wire and Instrument Panel Wire (Left Kick Panel)
IF1	Floor Wire and Instrument Panel Wire (Left Kick Panel)
IF2	Floor Wire and Instrument Panel Wire (Left Kick Panel)
IG1	Cowl Wire and Instrument Panel Wire (Lower Finish Panel)

IGNITION(LHD 7A-FE, 4A-FE)

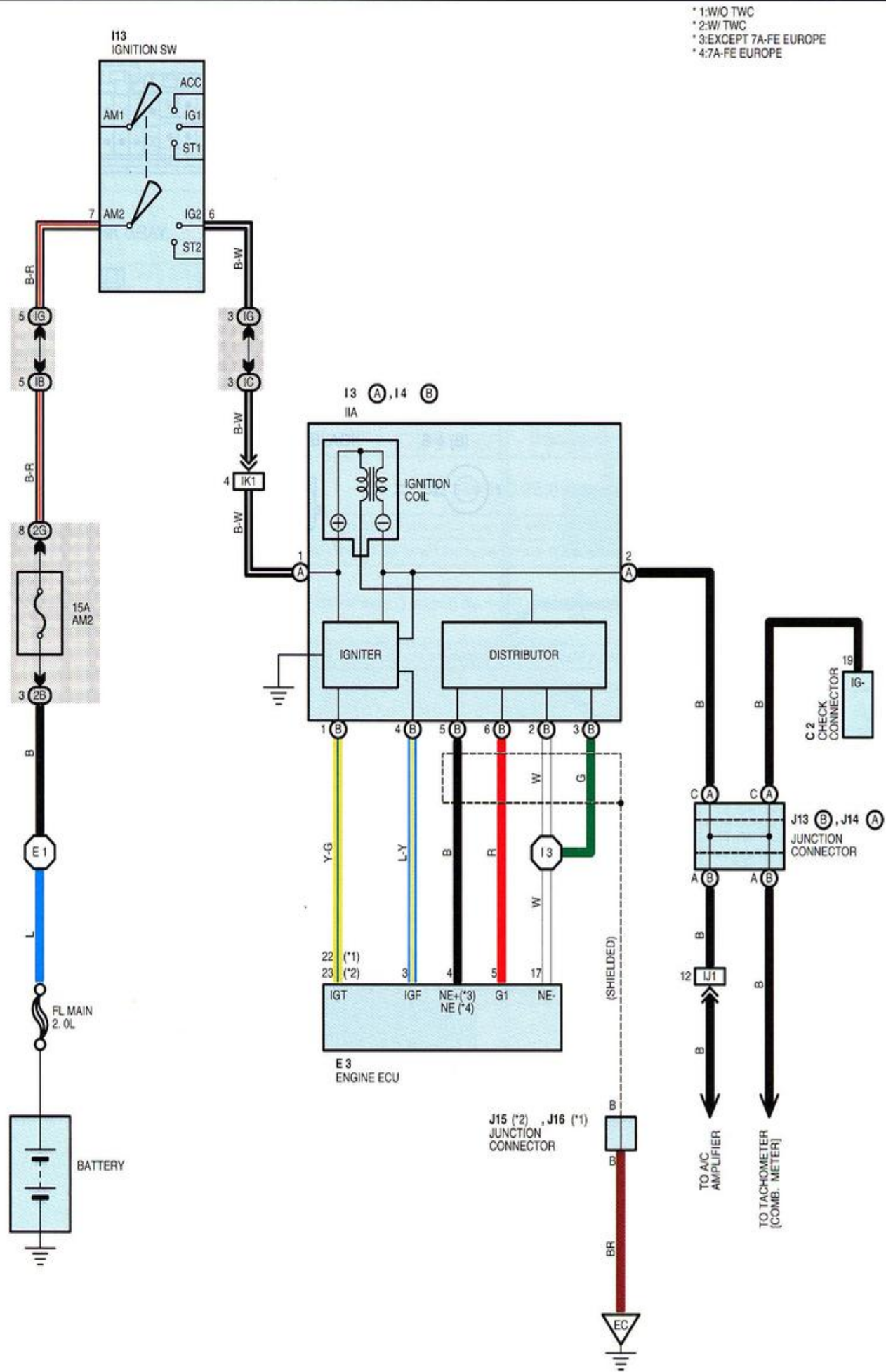

SERVICE HINTS

I13 IGNITION SW

7-6: Closed with the ignition SW at ON or ST position

○ : PARTS LOCATION

Code	See Page	Code	See Page	Code	See Page
C 2	70 (LHD 7A-FE)	I 3	A	72 (LHD 4A-FE)	J13 B
	72 (LHD 4A-FE)			70 (LHD 7A-FE)	J14 A
E 3	84 (LHD)	I 4	B	72 (LHD 4A-FE)	J15
I 3	A			70 (LHD 7A-FE)	I13

■ : JUNCTION BLOCK AND WIRE HARNESS CONNECTOR

Code	See Page	Junction Block and Wire Harness (Connector Location)
IB	56 (LHD)	Engine Room Main Wire and Instrument Panel J/B (Lower Finish Panel)
IC	56 (LHD)	Cowl Wire and Instrument Panel J/B (Lower Finish Panel)
IG	56 (LHD)	Instrument Panel Wire and Instrument Panel J/B (Lower Finish Panel)
2B	64	Engine Wire and Engine Room J/B (Engine Compartment Left)
2G	64	Engine Room Main Wire and Engine Room J/B (Engine Compartment Left)

□ : CONNECTOR JOINING WIRE HARNESS AND WIRE HARNESS

Code	See Page	Joining Wire Harness and Wire Harness (Connector Location)
IJ1	134 (LHD)	Instrument Panel Wire and Cowl Wire (Instrument Panel Brace RH)
IK1	134 (LHD)	Engine Wire and Cowl Wire (Instrument Panel Brace RH)

▽ : GROUND POINTS

Code	See Page	Ground Points Location
EC	122 (LHD 7A-FE)	Intake Manifold
	123 (LHD 4A-FE)	

○ : SPLICE POINTS

Code	See Page	Wire Harness with Splice Points	Code	See Page	Wire Harness with Splice Points
E 1	122 (LHD 7A-FE)	Engine Wire	I 3	134 (LHD)	Engine Wire
	123 (LHD 4A-FE)				

ENGINE CONTROL (LHD 4E-FE)

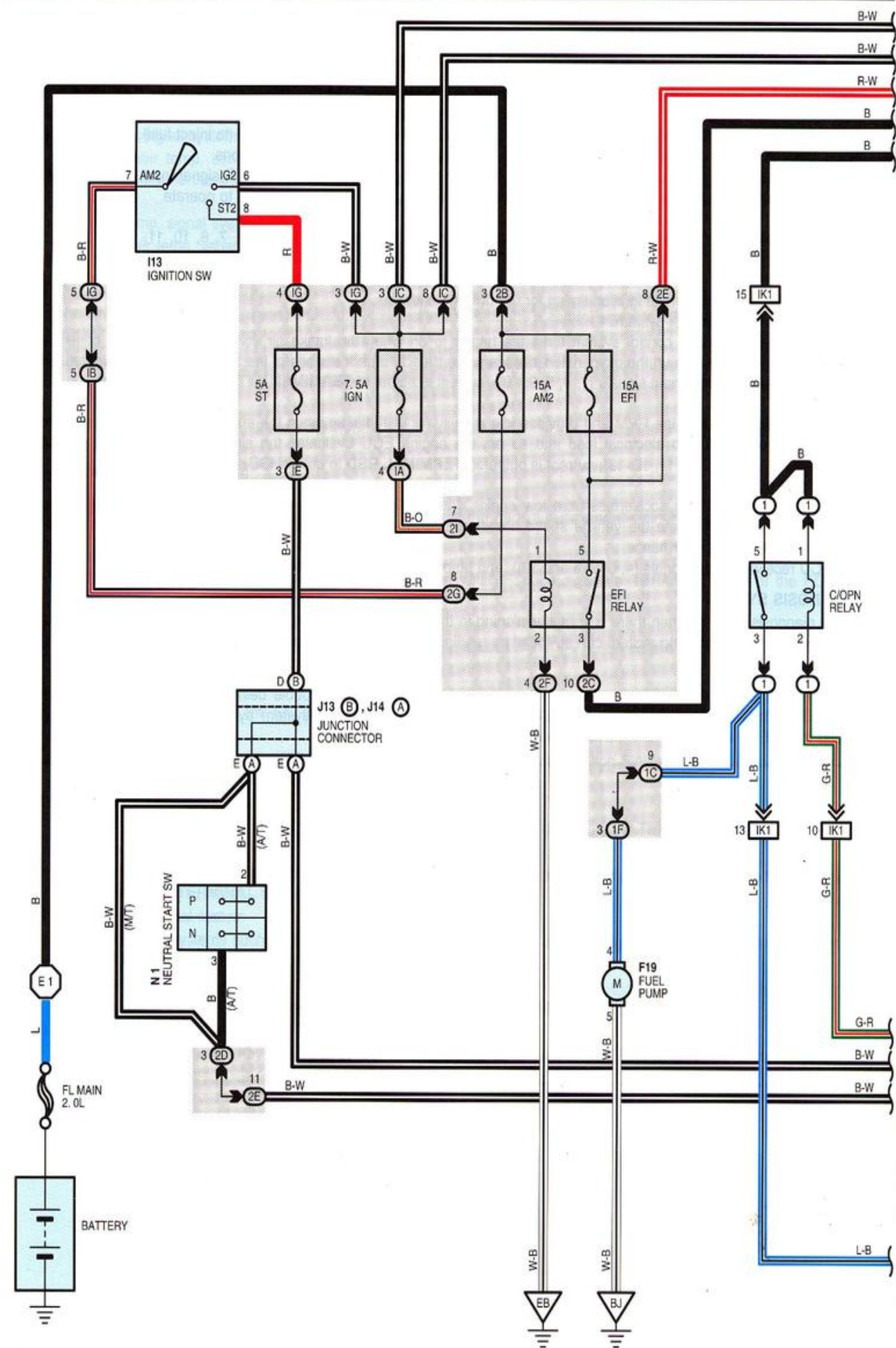

*1:A/T
*2:MT

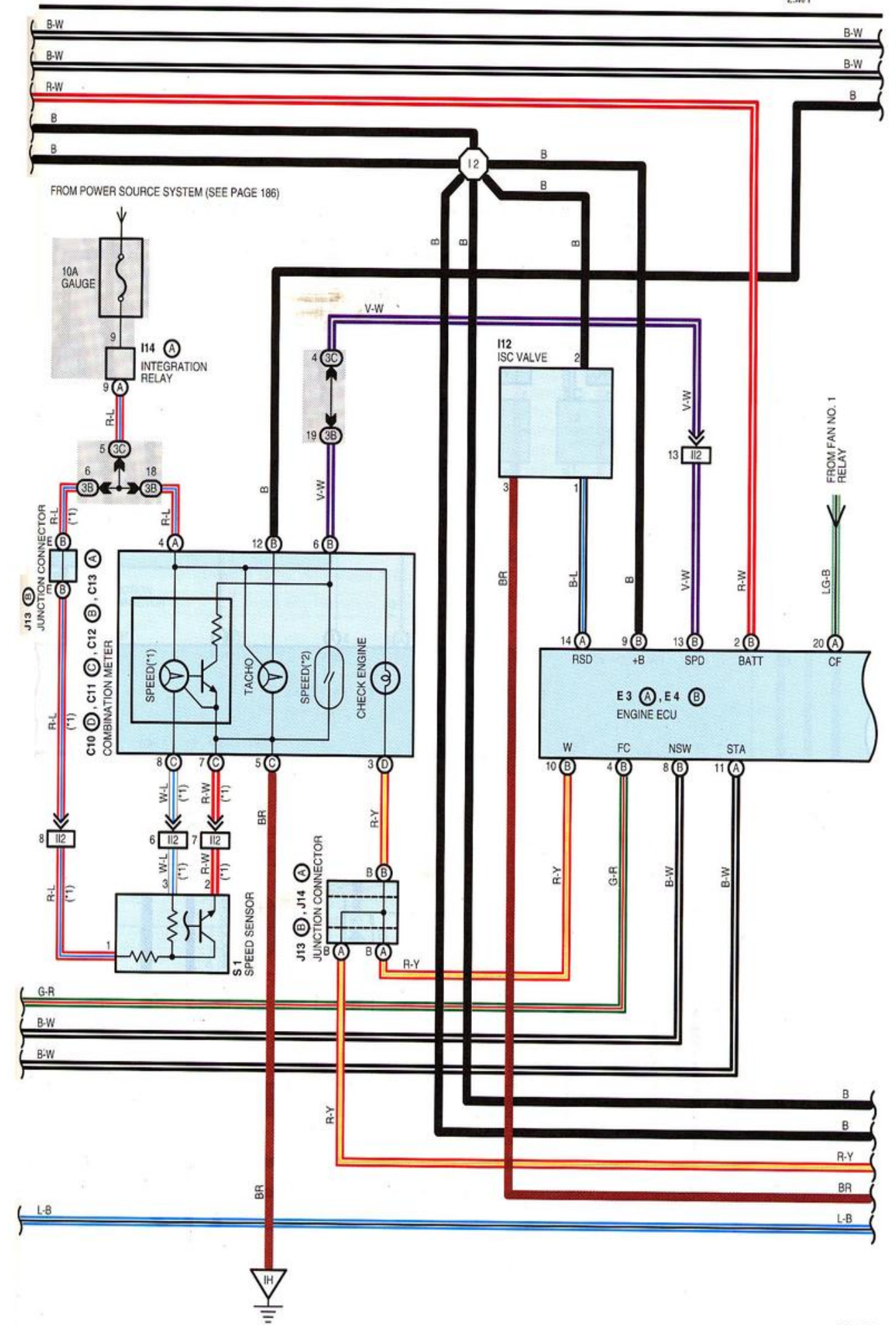

REAR FOG LIGHT(LHD)

SERVICE HINTS

R 4 REAR FOG LIGHT SW

- 1-GROUND: Approx. 12 volts with the light control SW at **HEAD** or **TAIL** position and the rear fog light SW at **ON** position
- 2-GROUND: Approx. 12 volts with the light control SW at **HEAD** or **TAIL** position
- 7-GROUND: Always continuity
- 3, 4, 5-GROUND: Always approx. 12 volts

○ : PARTS LOCATION

Code	See Page	Code	See Page	Code	See Page
C10	D 84 (LHD)	J 2	B 86 (LHD)	J27	88 (LHD S/D)
C11	C 84 (LHD)	J 6	B 86 (LHD)	R 4	86 (LHD)
C14	84 (LHD)	J 7	A 86 (LHD)	R 7	A 90 (LHD L/B) 92 (LHD H/B)
D 2	84 (LHD)	J 8	B 86 (LHD)		
I14	A 84 (LHD)	J 9	A 86 (LHD)	R 8	B 88 (LHD S/D)
J 1	A 86 (LHD)	J12	86 (LHD)	R11	94 (LHD W/G)

○ : JUNCTION BLOCK AND WIRE HARNESS CONNECTOR

Code	See Page	Junction Block and Wire Harness (Connector Location)
IE	56 (LHD)	Instrument Panel Wire and Instrument Panel J/B (Lower Finish Panel)
IJ		
1B	60 (LHD)	Cowl Wire and Driver Side J/B (Left Kick Panel)
1C		
1E	60 (LHD)	Instrument Panel Wire and Driver Side J/B (Left Kick Panel)
2B	64	Engine Wire and Engine Room J/B (Engine Compartment Left)
2G	64	Engine Room Main Wire and Engine Room J/B (Engine Compartment Left)
2I		
3A	66	Instrument Panel Wire and Center J/B (Behind the Combination Meter)
3C		
3D		

□ : CONNECTOR JOINING WIRE HARNESS AND WIRE HARNESS

Code	See Page	Joining Wire Harness and Wire Harness (Connector Location)
IF2	132 (LHD)	Floor Wire and Instrument Panel Wire (Left Kick Panel)
BC1	142 (LHD W/G)	Back Door No.1 Wire and Floor Wire (Right Quarter Pillar)
BD1	142 (LHD W/G)	Back Door No.1 Wire and Back Door No.2 Wire (Back Door Right)

▽ : GROUND POINTS

Code	See Page	Ground Points Location
IE	132 (LHD)	Left Kick Panel
IG	132 (LHD)	Instrument Panel Brace LH
BJ	136 (LHD S/D)	Under the Left Quarter Pillar
	140 (LHD H/B)	
BL	138 (LHD L/B)	Back Panel Center
	142 (LHD W/G)	Rear Quarter Panel RH
BN	142 (LHD W/G)	Back Door LH

○ : SPLICE POINTS

Code	See Page	Wire Harness with Splice Points	Code	See Page	Wire Harness with Splice Points
E 1	122 (LHD 7A-FE)	Engine Wire	E 1	126 (LHD 2E)	Engine Wire
	123 (LHD 4A-FE)			128 (LHD 2C-E)	
	124 (LHD 4E-FE)		B 8	142 (LHD W/G)	Back Door No.2 Wire

C10 (D) GARY

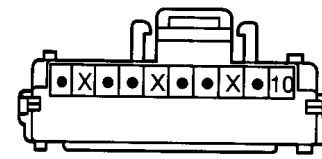

C11 (C) BLUE

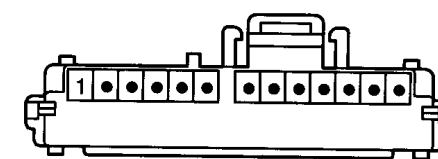

C14

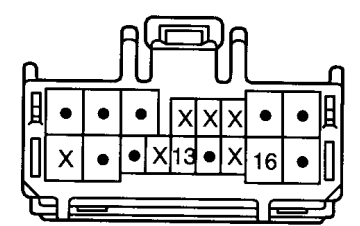

D 2 BLUE

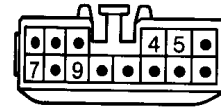

I14 (A)

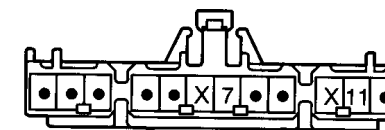

J 1 (A) BLACK

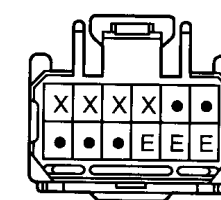

J 2 (B) BLACK

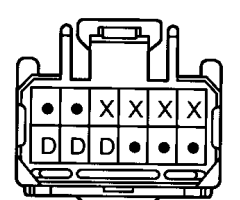

(Hint:See Page 7, 23, 39)

(Hint:See Page 7, 23, 39)

J 6 (B)

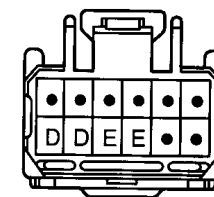

(Hint:See Page 7, 23, 39)

J 7 (A)

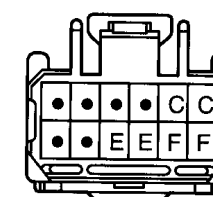

(Hint:See Page 7, 23, 39)

J 8 (B) GRAY

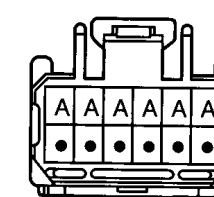

(Hint:See Page 7, 23, 39)

J 9 (A) GRAY

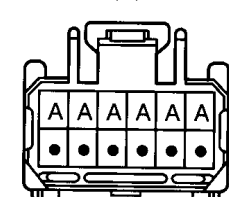

(Hint:See Page 7, 23, 39)

J12

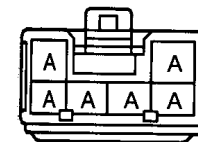

(Hint:See Page 7, 23, 39)

J27

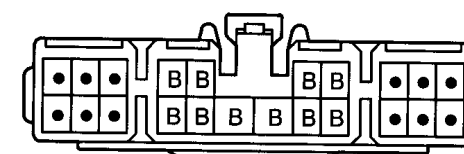

(Hint:See Page 7, 23, 39)

R 4 BLACK

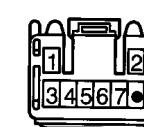

R 7 (A)

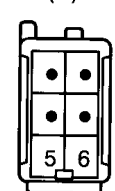

R 8(B)

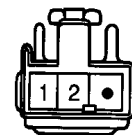

R11

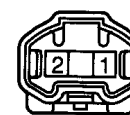

BACK-UP LIGHT(LHD)

FROM POWER SOURCE SYSTEM (SEE PAGE 186)

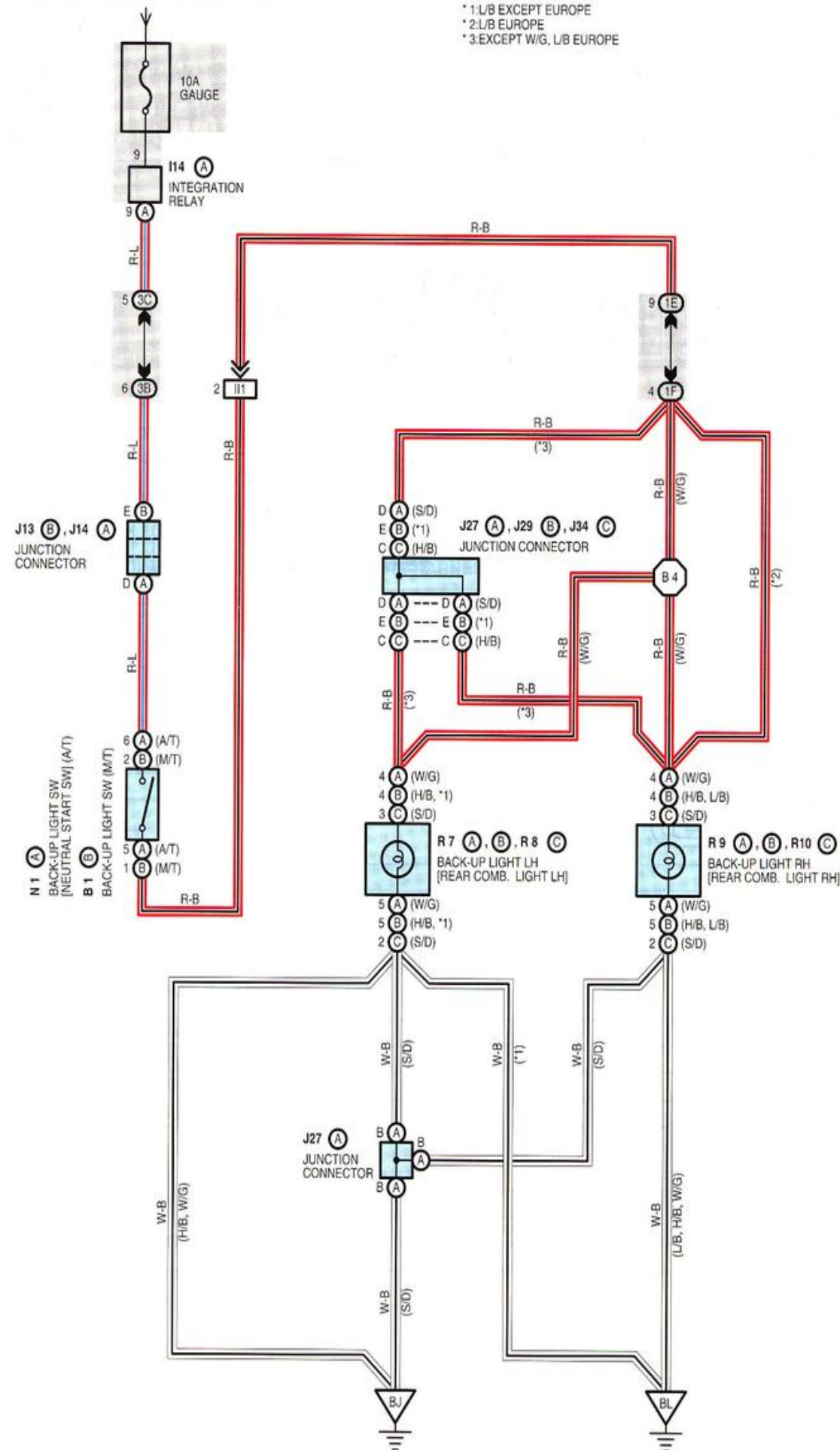

SERVICE HINTS

N 1 (A) BACK-UP LIGHT SW [NEUTRAL START SW] (A/T)

6-5 : Closed with the shift lever at **R** position

B 1 (B) BACK-UP LIGHT SW (M/T)

2-1 : Closed with the shift lever at **R** position

○ : PARTS LOCATION

Code	See Page	Code	See Page	Code	See Page			
B 1	B	70 (LHD 7A-FE)	J14	A	86 (LHD)			
		72 (LHD 4A-FE)	J27	A	88 (LHD S/D)			
		74 (LHD 4E-FE)	J29	B	90 (LHD L/B)			
		76 (LHD 4A-F)	J34	C	92 (LHD H/B)			
		78 (LHD 2E)	N 1	A	70 (LHD 7A-FE)	R 7	A	94 (LHD W/G)
		80 (LHD 2C-E)			72 (LHD 4A-FE)	R 9	B	90 (LHD L/B)
82 (LHD 2C)	74 (LHD 4E-FE)	92 (LHD H/B)						
I14	A	84 (LHD)			R 8	C	88 (LHD S/D)	
J13	B	86 (LHD)			R 9	B	90 (LHD L/B)	
					R10	C	88 (LHD S/D)	

□ : JUNCTION BLOCK AND WIRE HARNESS CONNECTOR

Code	See Page	Junction Block and Wire Harness (Connector Location)
1E	60 (LHD)	Instrument Panel Wire and Driver Side J/B (Left Kick Panel)
1F	60 (LHD)	Floor Wire and Driver Side J/B (Left Kick Panel)
3B	66	Instrument Panel Wire and Center J/B (Behind the Combination Meter)
3C		

□ : CONNECTOR JOINING WIRE HARNESS AND WIRE HARNESS

Code	See Page	Joining Wire Harness and Wire Harness (Connector Location)
I11	134 (LHD)	Engine Wire and Instrument Panel Wire (Instrument Panel Brace LH)

▽ : GROUND POINTS

Code	See Page	Ground Points Location
B.J.	136 (LHD S/D)	Under the Left Quarter Pillar
	140 (LHD H/B)	
	142 (LHD W/G)	
B.L.	138 (LHD L/B)	Back Panel Center
	140 (LHD H/B)	Back Panel LH
	142 (LHD W/G)	Rear Quarter Panel RH

○ : SPLICE POINTS

Code	See Page	Wire Harness with Splice Points	Code	See Page	Wire Harness with Splice Points
B 4	142 (LHD W/G)	Floor Wire			

REAR WIPER AND WASHER(LHD H/B,W/G w/ HEATER)

FROM POWER SOURCE SYSTEM (SEE PAGE 186)

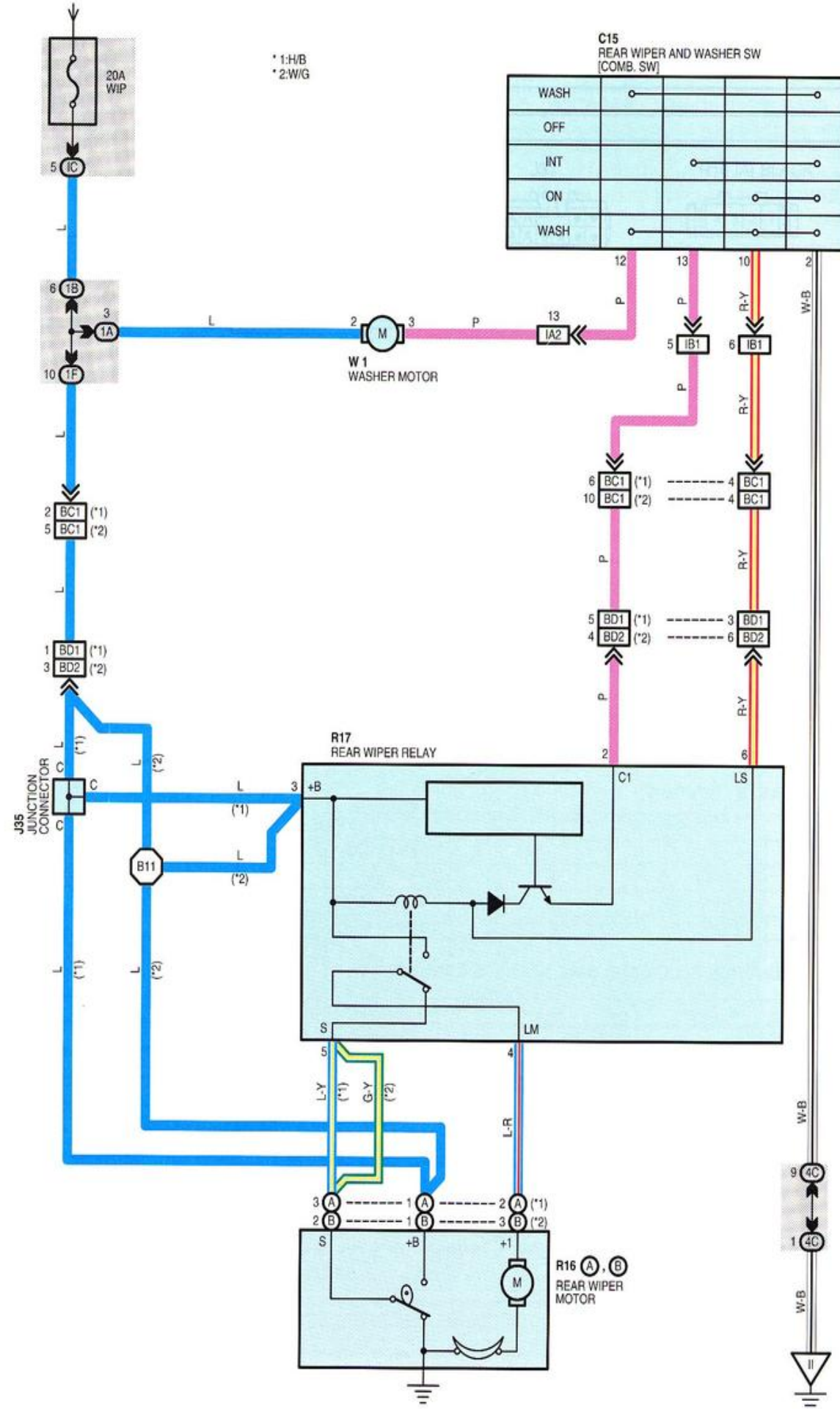

SYSTEM OUTLINE

When the ignition SW is turned on, current flows to **TERMINAL 2** of the washer motor, **TERMINAL 3** of the rear wiper relay and **TERMINAL +B** of the rear wiper motor through the **WIP** fuse.

1. REAR WIPER NORMAL OPERATION

With the ignition SW turned on and the rear wiper and washer SW turned on, the current flowing to **TERMINAL 3** of the rear wiper relay flows to **TERMINAL 6** of the relay to **TERMINAL 10** of the rear wiper and washer SW to **TERMINAL 2** to **GROUND**. Thus, the relay coil is activated and the current to **TERMINAL 3** of the relay flows to **TERMINAL 4** to **TERMINAL +1** of the rear wiper motor to motor to **GROUND** and causes the motor to operate the wiper.

2. REAR WIPER INTERMITTENT OPERATION

When the ignition SW is on and the rear wiper and washer SW is turned to **INT** position, current flowing to **TERMINAL 3** of the rear wiper relay flows to **TERMINAL 2** to **TERMINAL 13** of the rear wiper and washer SW to **TERMINAL 2** to **GROUND**. This causes the motor to operate (The point changes) and the intermittent circuit of the relay operates. Intermittent operation of the circuit is controlled by the charging and discharging of the condenser installed inside the relay.

3. WASHER OPERATION

With the ignition SW turned on and the rear wiper and washer SW turned to **ON** position, when the wiper SW is turned further, the current flowing to **TERMINAL 2** of the washer motor flows to **TERMINAL 3** of the motor to **TERMINAL 12** of the rear wiper and washer SW to **TERMINAL 2** to **GROUND** so that the washer motor rotates and the window washer emits a water spray, only while the switch is fully turned.

When the wiper SW is off and then turned to washer on (Wiper off side), Only the washer operates.

SERVICE HINTS

W 1 WASHER MOTOR

- 2-GROUND: Approx. 12 volts with ignition SW at ON position
- 3-GROUND: Continuity with washer SW turned on

R17 REAR WIPER RELAY

- 3-GROUND: Approx. 12 volts with ignition SW at ON position
- 2-GROUND: Continuity with rear wiper SW at INT position
- 6-GROUND: Continuity with rear wiper SW at ON position

○ : PARTS LOCATION

Code	See Page	Code	See Page	Code	See Page
C15	84 (LHD)	R17	92 (LHD H/B)	W 1	74 (LHD 4E-FE)
J35	92 (LHD H/B)		94 (LHD W/G)		78 (LHD 2E)
R16	A	92 (LHD H/B)	70 (LHD 7A-FE)		80 (LHD 2C-E)
	B	94 (LHD W/G)	72 (LHD 4A-FE)		

⊠ : JUNCTION BLOCK AND WIRE HARNESS CONNECTOR

Code	See Page	Junction Block and Wire Harness (Connector Location)
IC	56 (LHD)	Cowl Wire and Instrument Panel J/B (Lower Finish Panel)
1A	60 (LHD)	Engine Room Main Wire and Driver Side J/B (Left Kick Panel)
1B	60 (LHD)	Cowl Wire and Driver Side J/B (Left Kick Panel)
1F	60 (LHD)	Floor Wire and Driver Side J/B (Left Kick Panel)
4C	68 (LHD)	Cowl Wire and J/B No.4 (Right Kick Panel)

□ : CONNECTOR JOINING WIRE HARNESS AND WIRE HARNESS

Code	See Page	Joining Wire Harness and Wire Harness (Connector Location)
IA2	132 (LHD)	Engine Room Main Wire and Cowl Wire (Near the Driver Side R/B)
IB1	132 (LHD)	Floor Wire and Cowl Wire (Near the Driver Side J/B)
BC1	140 (LHD H/B)	Back Door No.1 Wire and Floor Wire (Left Quarter Pillar)
	142 (LHD W/G)	Back Door No.1 Wire and Floor Wire (Right Quarter Pillar)
BD1	140 (LHD H/B)	Back Door No.1 Wire and Back Door No.2 Wire (Back Door Left)
BD2	142 (LHD W/G)	Back Door No.1 Wire and Back Door No.2 Wire (Back Door Right)

WIRELESS DOOR LOCK CONTROL(LHD)

SYSTEM OUTLINE

Door lock control (Lock and unlock) is performed by remote control, without the ignition key inserted in the door key cylinder, using low-power electrical waves emitted by a transmitter.

1. WIRELESS DOOR LOCK OR UNLOCK NORMAL OPERATION

With the ignition key not inserted into the ignition key cylinder (Unlock warning SW off) and all the doors completely closed, when the lock or unlock button (Transmitter) is pushed, the door control receiver receives the electrical waves from the transmitter, causing it to operate.

As a result, the receiver judges whether the door is locked or unlocked based on the signal from the door lock motor and door unlock detection SW, and sends a signal to the integration relay to switch the condition from lock to unlock or vice versa, causing the door lock motor to operate.

2. AUTOMATIC LOCK OPERATION

With the ignition key not inserted into the ignition key cylinder (Unlock warning SW off) and all the doors completely closed, after pushing the button (Transmitter) to unlock all the doors, if a door is not opened within **30** seconds, all the doors will be automatically relocked.

3. WIRELESS CONTROL STOP FUNCTION

If a door is open (Door courtesy SW on), a signal is input from the door courtesy SW to the door control receiver, stopping wireless door lock or unlock.

If the ignition key is in the ignition key cylinder (Unlock warning SW on), the unlock warning SW inputs a signal to the door control receiver, stopping wireless door lock.

4. DOOR LOCK MOTOR PROTECTIVE FUNCTION

If the door lock or unlock condition does not change after wireless door lock or unlock operation, **2** seconds later, the integration relay sends current three times to the door lock motor. If the door lock condition still has not changed, as a result, the door control receiver stops reception and stops door lock and unlock function.

SERVICE HINTS

D11, D12, D13, D14 DOOR COURTESY SW FRONT LH, RH, REAR LH, RH

1-GROUND: Closed with the door open

U 1 UNLOCK WARNING SW

2-1 : Closed with the ignition key in the cylinder

D 7 DOOR CONTROL RECEIVER

8-GROUND : Always approx. **12** volts

1-GROUND : Always continuity

14-GROUND : Continuity with each of the door open

10-GROUND : Continuity with the ignition key in the cylinder

○ : PARTS LOCATION

Code	See Page	Code	See Page	Code	See Page		
B 8	A	94 (LHD W/G)	D15	J12	86 (LHD)		
	B	94 (LHD W/G)			J21	86 (LHD)	
B 9	A	94 (LHD W/G)	D17	J25	C	88 (LHD S/D)	
	B	94 (LHD W/G)			90 (LHD L/B)		
D 5	84 (LHD)	D18	J26	A	94 (LHD W/G)		
D 7	84 (LHD)				88 (LHD S/D)		
D 9	84 (LHD)				90 (LHD L/B)		
D10	90 (LHD L/B)	D19	J27	A	88 (LHD S/D)		
	92 (LHD H/B)				J29	B	90 (LHD L/B)
D11	88 (LHD S/D)	D20	J33	B	92 (LHD H/B)		
	90 (LHD L/B)				J34	C	92 (LHD H/B)
	92 (LHD H/B)				L 5	90 (LHD L/B)	
	94 (LHD W/G)					94 (LHD W/G)	
D12	88 (LHD S/D)	D13	J 3	P10	A	88 (LHD S/D)	
	90 (LHD L/B)				B	90 (LHD L/B)	
	92 (LHD H/B)					92 (LHD H/B)	
	94 (LHD W/G)				94 (LHD W/G)		
D13	88 (LHD S/D)	I14	A	84 (LHD)	U 1	86 (LHD)	
	90 (LHD L/B)	I15	B	84 (LHD)			
	94 (LHD W/G)	J 4	A	86 (LHD)			
D14	88 (LHD S/D)	J 5	B	86 (LHD)	86 (LHD)		
	90 (LHD L/B)	J10	B	86 (LHD)			
	94 (LHD W/G)	J11	A	86 (LHD)			
D15	88 (LHD S/D)						

○ : JUNCTION BLOCK AND WIRE HARNESS CONNECTOR

Code	See Page	Junction Block and Wire Harness (Connector Location)
ID	56 (LHD)	Cowl Wire and Instrument Panel J/B (Lower Finish Panel)
IE	56 (LHD)	Instrument Panel Wire and Instrument Panel J/B (Lower Finish Panel)
1C	60 (LHD)	Cowl Wire and Driver Side J/B (Left Kick Panel)
1E	60 (LHD)	Instrument Panel Wire and Driver Side J/B (Left Kick Panel)
1F	60 (LHD)	Floor Wire and Driver Side J/B (Left Kick Panel)
2I	64	Engine Room Main Wire and Engine Room J/B (Engine Compartment Left)
3B	66	Instrument Panel Wire and Center J/B (Behind the Combination Meter)
3C		
3D		
4C	68 (LHD)	Cowl Wire and J/B No.4 (Right Kick Panel)

ABS(LHD EXCEPT EUROPE)

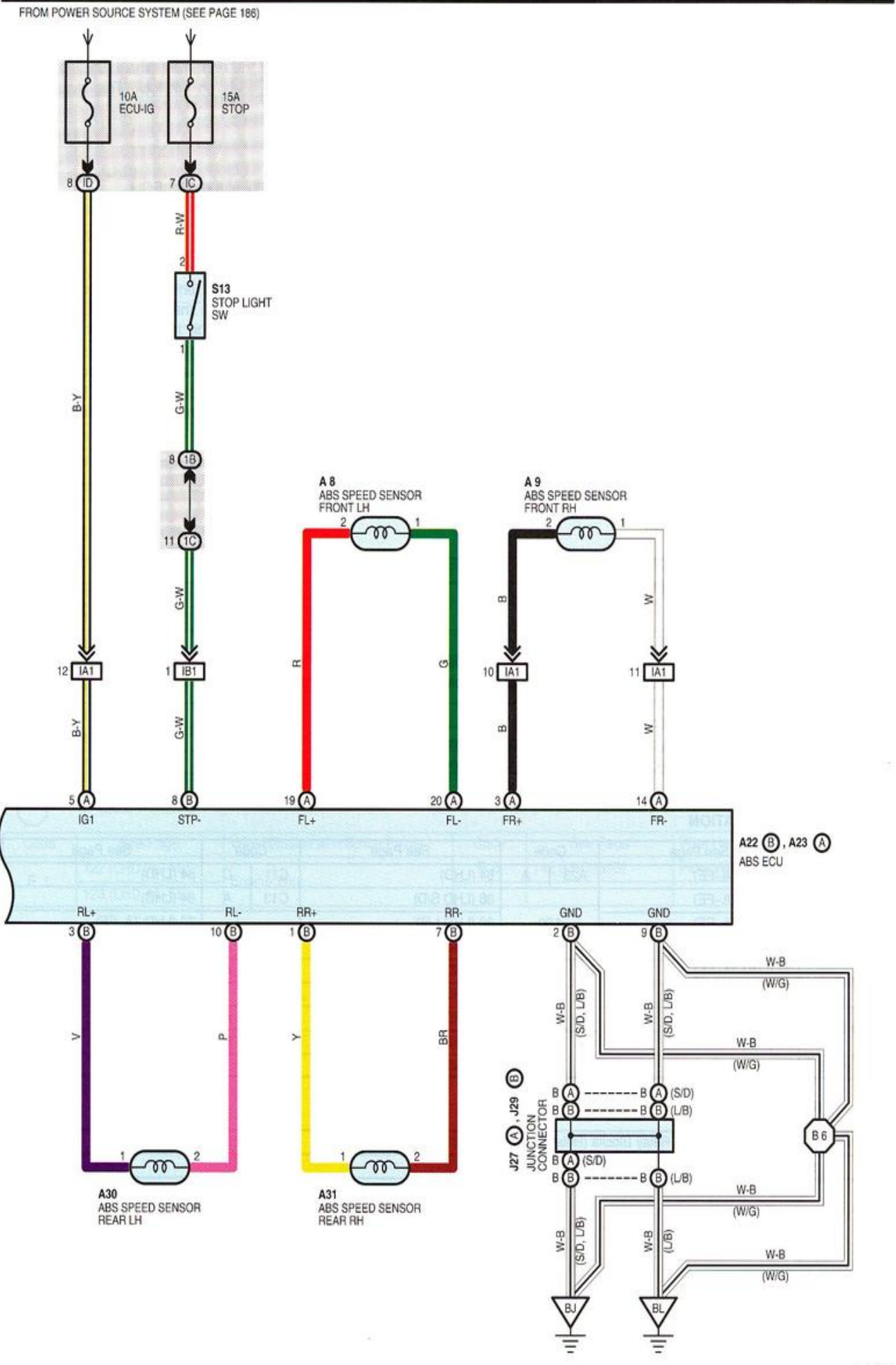
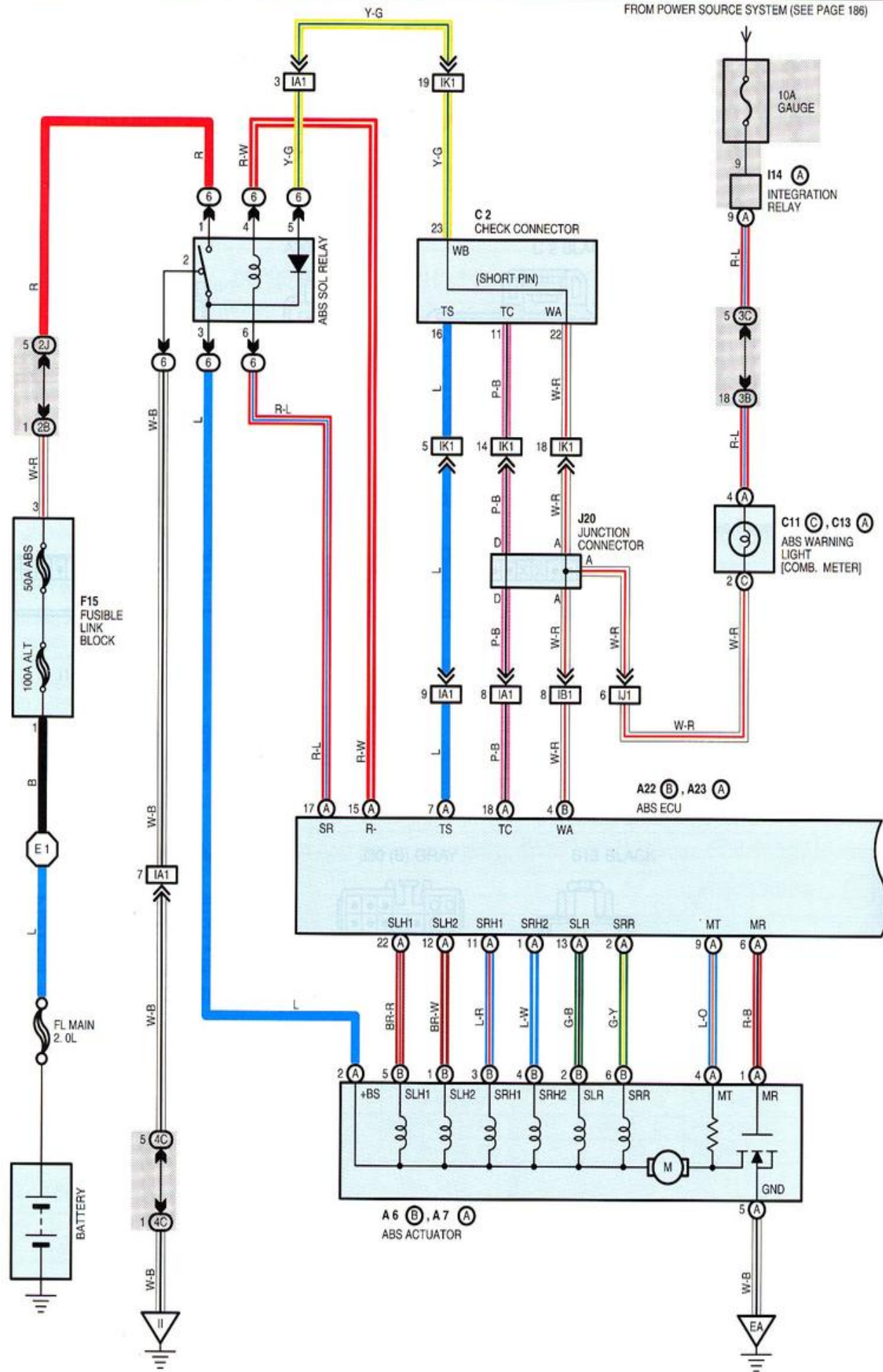

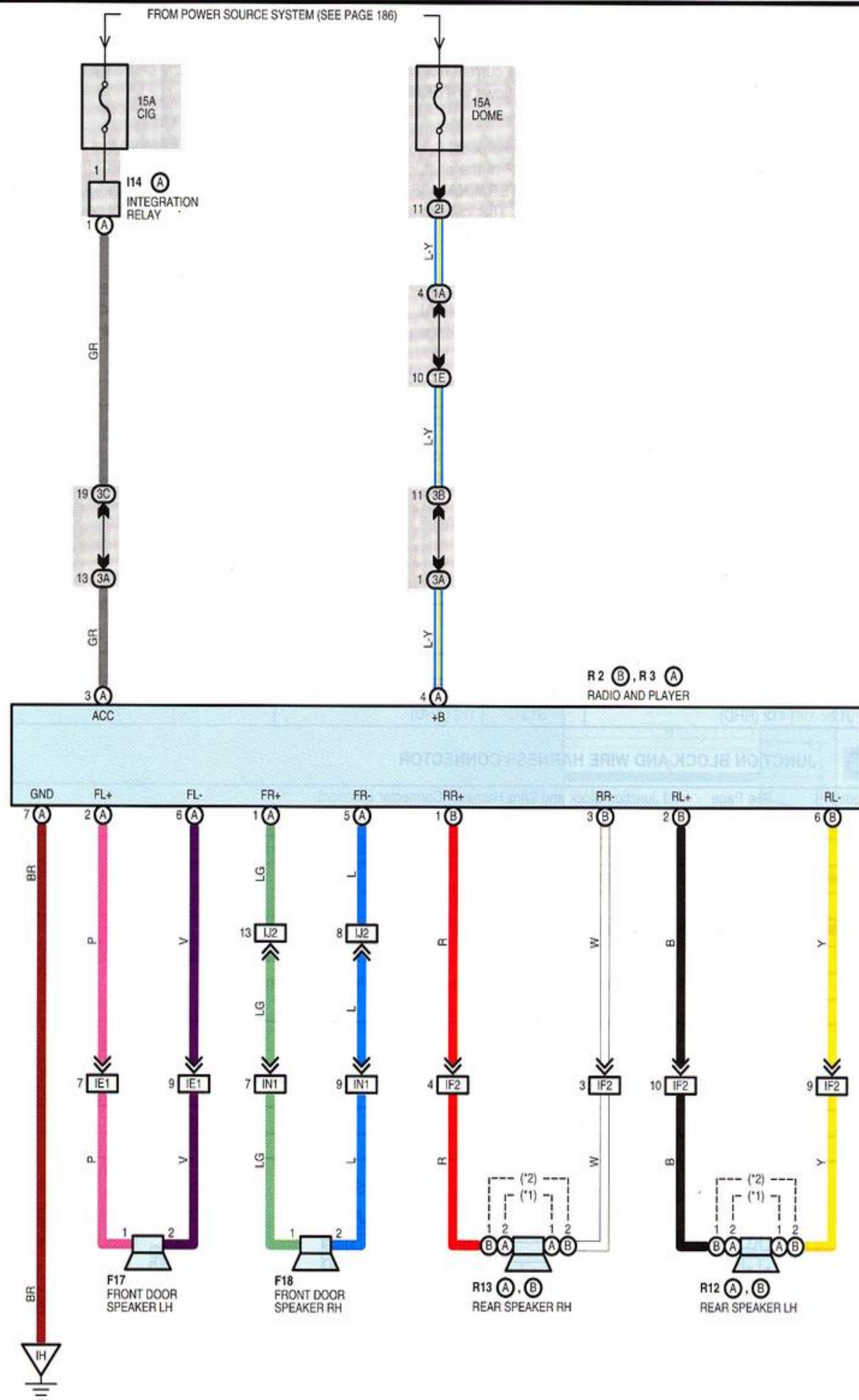

SERVICE HINTS

R 3 (A) RADIO AND PLAYER

- (A) 4-GROUND: Always approx. 12 volts
- (A) 3-GROUND: Approx. 12 volts with the ignition SW at ACC or ON position
- (A) 7-GROUND: Always continuity

○ : PARTS LOCATION

Code	See Page	Code	See Page	Code	See Page			
F17	88 (LHD S/D)	F18	94 (LHD W/G)	R12	B	94 (LHD W/G)		
	90 (LHD L/B)		I14	A	84 (LHD)	R13	A	88 (LHD S/D)
	92 (LHD H/B)		R 2	B	86 (LHD)		90 (LHD L/B)	
	94 (LHD W/G)		R 3	A	86 (LHD)		92 (LHD H/B)	
F18	88 (LHD S/D)	R12	A	88 (LHD S/D)	B	94 (LHD W/G)		
	90 (LHD L/B)		90 (LHD L/B)					
	92 (LHD H/B)		92 (LHD H/B)					

○ : JUNCTION BLOCK AND WIRE HARNESS CONNECTOR

Code	See Page	Junction Block and Wire Harness (Connector Location)
1A	60 (LHD)	Engine Room Main Wire and Driver Side J/B (Left Kick Panel)
1E	60 (LHD)	Instrument Panel Wire and Driver Side J/B (Left Kick Panel)
2I	64	Engine Room Main Wire and Engine Room J/B (Engine Compartment Left)
3A	66	Instrument Panel Wire and Center J/B (Behind the Combination Meter)
3B		
3C		

□ : CONNECTOR JOINING WIRE HARNESS AND WIRE HARNESS

Code	See Page	Joining Wire Harness and Wire Harness (Connector Location)
IE1	132 (LHD)	Front Door LH Wire and Instrument Panel Wire (Left Kick Panel)
IF2	132 (LHD)	Floor Wire and Instrument Panel Wire (Left Kick Panel)
IJ2	134 (LHD)	Instrument Panel Wire and Cowl Wire (Instrument Panel Brace RH)
IN1	134 (LHD)	Front Door RH Wire and Cowl Wire (Right Kick Panel)

▽ : GROUND POINTS

Code	See Page	Ground Points Location
IH	132 (LHD)	Instrument Panel Brace RH

F17, F18

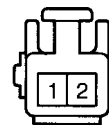

I14 (A)

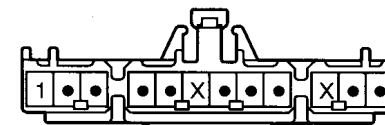

R 2 (B)



R 3 (A)

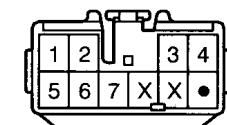

(S/D) R12 (A), R13 (A)



(L/B, H/B) R12 (A), R13 (A) R12 (B), R13 (B)

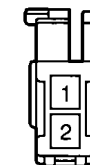

SERVICE HINTS

A 4 A/C DUAL PRESSURE SW

1-4 :open with the pressure less than **2.0 kg/cm² (28.4 psi, 196 kpa)** or above **32 kg/cm² (455 psi, 3138 kpa)**

A15 A/C AMPLIFIER

7-13 :Continuity with the A/C SW (inside the heater control SW) on and the ignition SW at **ON** position

5-GROUND :Approx. **12** volts with the ignition SW on and blower SW on

3-GROUND :Always continuity

13-GROUND :Always continuity

1-GROUND :Always continuity

B 5 BLOWER RESISTOR

4-2 :Approx. **0.40** ohm

4-3 :Approx. **1.20** ohm

4-1 :Approx. **3.20** ohm

B 6 BLOWER SW

8-1 :Continuity with the blower SW at **LO, M1, M2** and **HI** position

6-1 :Continuity with the blower SW at **M1** position

5-1 :Continuity with the blower SW at **M2** position

4-1 :Continuity with the blower SW at **HI** position

○ : PARTS LOCATION

Code	See Page	Code	See Page	Code	See Page
A 2	76 (LHD 4A-F)	B 6	84 (LHD)	J11	A 86 (LHD)
A 3	78 (LHD 2E)	B 7	84 (LHD)	J12	86 (LHD)
A 4	76 (LHD 4A-F)	H13	84 (LHD)	J13	B 86 (LHD)
	78 (LHD 2E)		76 (LHD 4A-F)	J14	A 86 (LHD)
A 5	78 (LHD 2E)	I 3	78 (LHD 2E)	J17	86 (LHD)
A15	84 (LHD)		I14	A 84 (LHD)	J18
A21	84 (LHD)	J 8	B 86 (LHD)	J19	86 (LHD)
B 4	84 (LHD)	J 9	A 86 (LHD)	V 4	76 (LHD 4A-F)
B 5	84 (LHD)	J10	B 86 (LHD)		78 (LHD 2E)

○ : RELAY BLOCKS

Code	See Page	Relay Blocks (Relay Block Location)
5	55	Engine Room R/B (Engine Compartment Left)

○ : JUNCTION BLOCK AND WIRE HARNESS CONNECTOR

Code	See Page	Junction Block and Wire Harness (Connector Location)
ID	56 (LHD)	Cowl Wire and Instrument Panel J/B (Lower Finish Panel)
1C	60 (LHD)	Cowl Wire and Driver Side J/B (Left Kick Panel)
1E	60 (LHD)	Instrument Panel Wire and Driver Side J/B (Left Kick Panel)
2C	64	Engine Wire and Engine Room J/B (Engine Compartment Left)
2E		
2F	64	Engine Room Main Wire and Engine Room J/B (Engine Compartment Left)
2I		
3C	66	Instrument Panel Wire and Center J/B (Behind the Combination Meter)
3D		
4B	68 (LHD)	Cowl Wire and J/B No.4 (Right Kick Panel)
4C		

□ : CONNECTOR JOINING WIRE HARNESS AND WIRE HARNESS

Code	See Page	Joining Wire Harness and Wire Harness (Connector Location)
IA2	132 (LHD)	Engine Room Main Wire and Cowl Wire (Near the Driver Side R/B)
IJ1	134 (LHD)	Instrument Panel Wire and Cowl Wire (Instrument Panel Brace RH)
IJ2		
IK1	134 (LHD)	Engine Wire and Cowl Wire (Instrument Panel Brace RH)
IL1	134 (LHD)	Cowl Wire and A/C Sub Wire (Behind the Glove Box)

▽ : GROUND POINTS

Code	See Page	Ground Points Location
EB	126 (LHD 2E)	Front Side of Left Fender
IE	132 (LHD)	Left Kick Panel
IG	132 (LHD)	Instrument Panel Brace LH
II	132 (LHD)	Right Kick Panel

○ : SPLICE POINTS

Code	See Page	Wire Harness with Splice Points	Code	See Page	Wire Harness with Splice Points
I 4	134 (LHD)	Cowl Wire	I 5	134 (LHD)	A/C Sub Wire

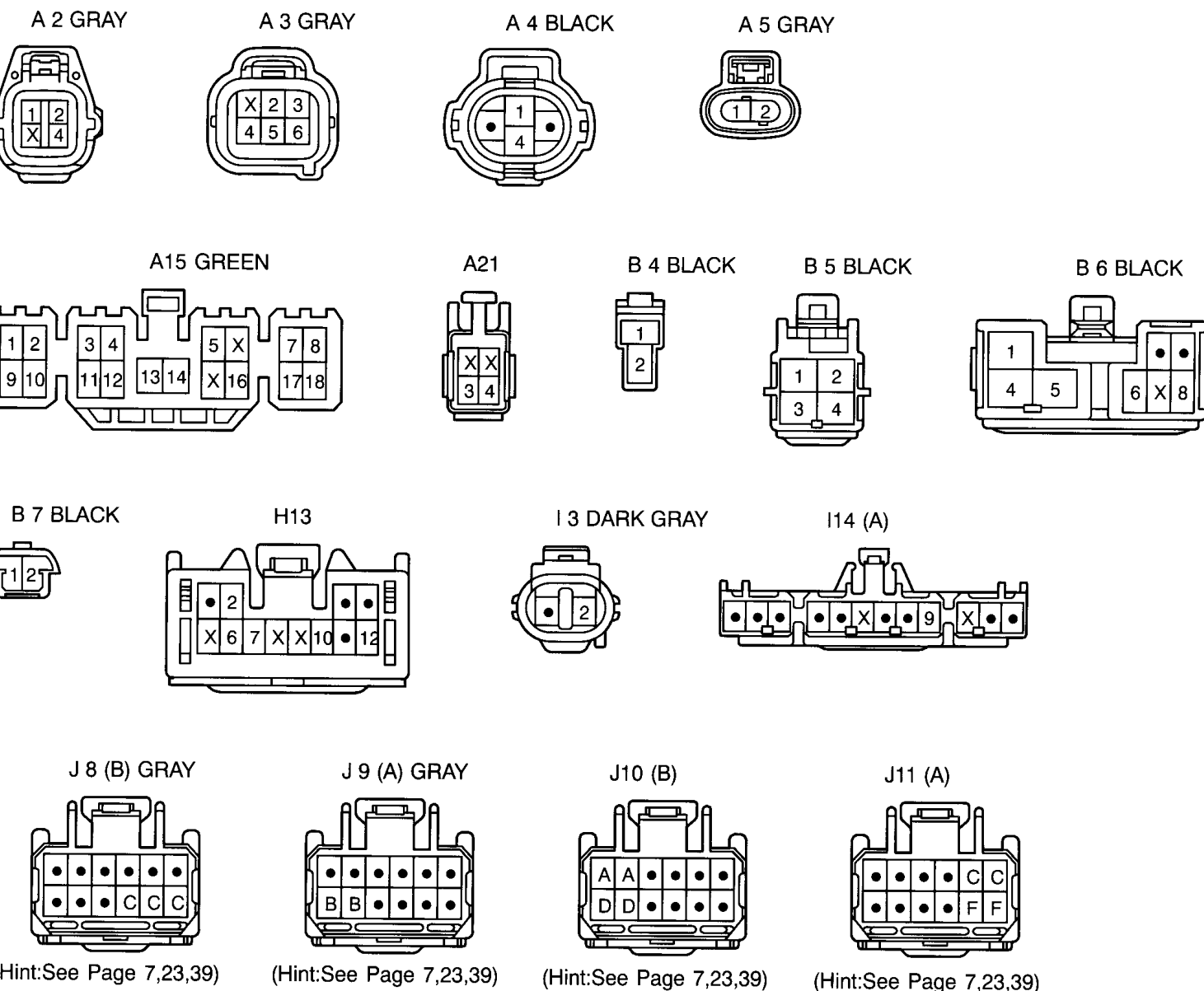

4 COROLLA(LHD)

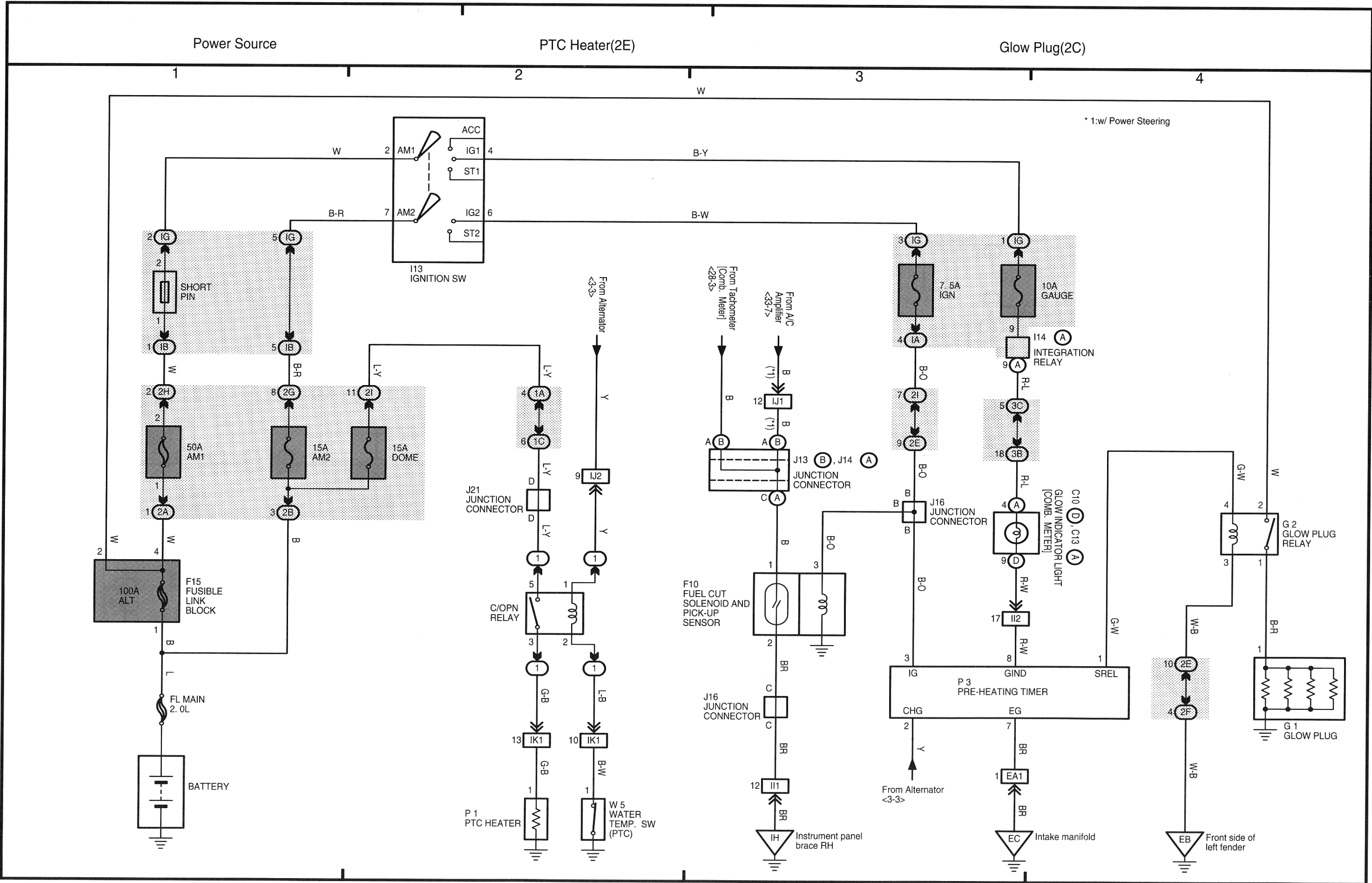

13 COROLLA(LHD)

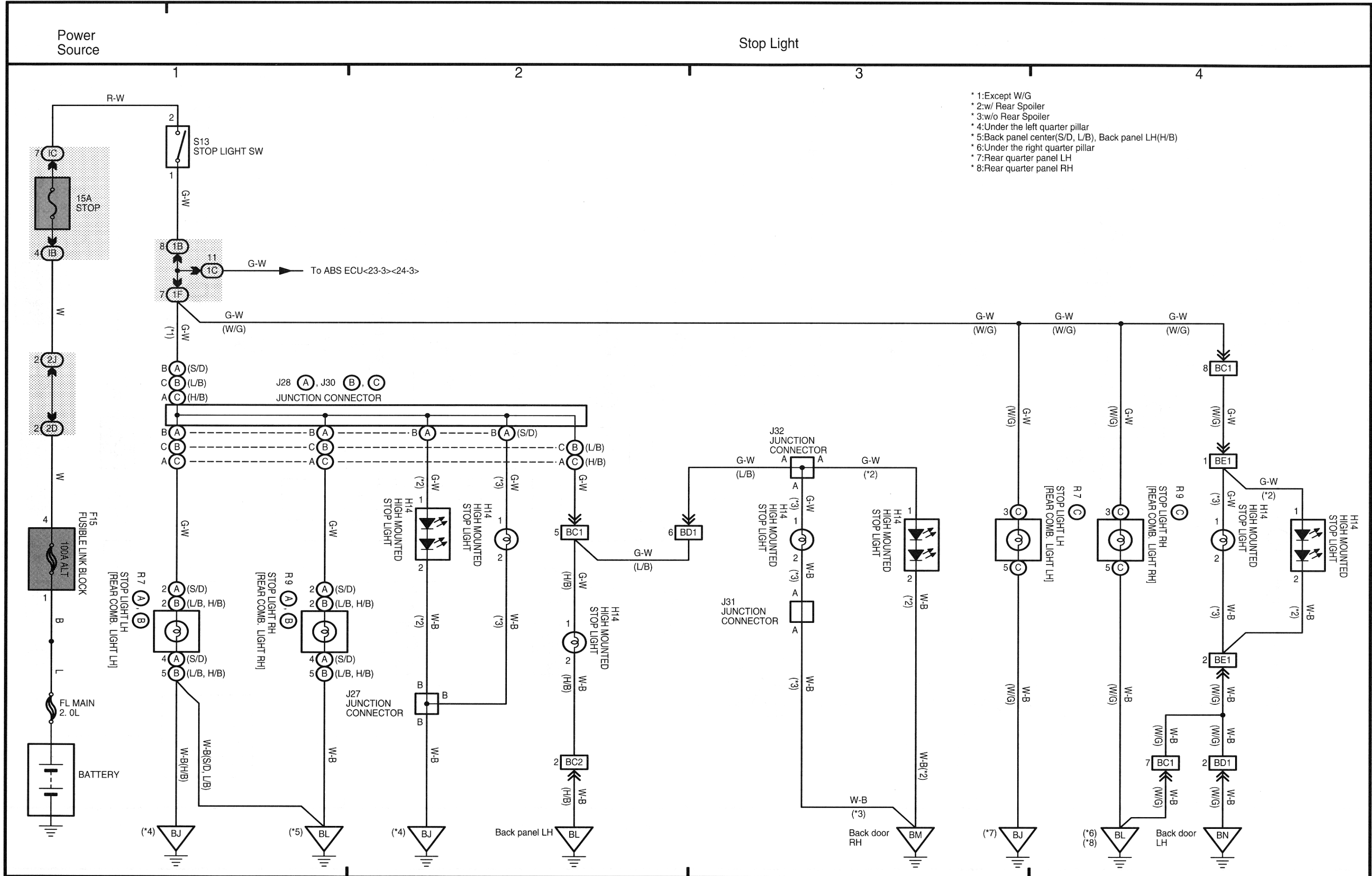

- * 1: Except W/G
- * 2: w/ Rear Spoiler
- * 3: w/o Rear Spoiler
- * 4: Under the left quarter pillar
- * 5: Back panel center (S/D, L/B), Back panel LH (H/B)
- * 6: Under the right quarter pillar
- * 7: Rear quarter panel LH
- * 8: Rear quarter panel RH

K OVERALL ELECTRICAL WIRING DIAGRAM