

**TABLE OF CONTENT****PART A**

<b>1</b>	<b>TECHNICAL SPECIFICATIONS .....</b>	<b>1</b>
<b>2</b>	<b>GENERAL ELECTRICAL PRECAUTIONS .....</b>	<b>3</b>
<b>3</b>	<b>CHARGING AND STARTING SYSTEM .....</b>	<b>6</b>
3.1	BATTERY.....	6
3.2	ALTERNATOR.....	12
3.3	STARTER MOTOR.....	28
<b>4</b>	<b>LIGHTING SYSTEM.....</b>	<b>42</b>
4.1	BULB SPECIFICATIONS.....	42
4.2	TORQUE VALUE TABLE.....	42
4.3	DIAGNOSTIC INFORMATION AND PROCEDURES FOR ALL LAMPS.....	43
4.4	HEAD LAMP.....	46
4.5	TAIL LAMP.....	50
4.6	REGISTRATION PLATE LAMP.....	52
4.7	SIDE REPEATER LAMP.....	53
4.8	ENGINE LAMP.....	54
4.9	HIGH MOUNTED STOP LAMP.....	55
4.10	FRONT ROOF LAMP.....	56
4.11	REAR ROOF LAMP.....	57
4.12	FRONT FOG LAMP.....	58
4.13	REAR FOG LAMP.....	59
4.14	PUDDLE LAMP.....	60
4.15	DOOR AJAR LAMP.....	61
4.16	REVERSE INDICATOR LAMP.....	62
<b>5</b>	<b>FUSE AND RELAY BOX.....</b>	<b>63</b>
<b>6</b>	<b>HORN.....</b>	<b>70</b>

---

---

---

## ELECTRICAL

---

<b>7</b>	<b>CIGAR LIGHTER</b> .....	<b>72</b>
<b>8</b>	<b>BUZZER</b> .....	<b>73</b>
<b>9</b>	<b>WIPER AND WASHER SYSTEM</b> .....	<b>74</b>
<b>10</b>	<b>INSTRUMENT CLUSTER</b> .....	<b>82</b>
<b>11</b>	<b>SWITCHES</b> .....	<b>96</b>
11.1	COMBINATION SWITCH.....	96
11.2	STEERING LOCK CUM IGNITION SWITCH .....	103
11.3	FACIA SWITCHES.....	105
11.3.1	TRANSFER (4X4) SWITCH .....	106
11.3.2	HEAD LAMP LEVELLING SWITCH .....	106
11.4	HAZARD WARNING SWITCH.....	107
11.5	WINDOW WINDING SWITCHES.....	109
11.6	REVERSE LIGHT SWITCH .....	111
11.7	PASSENGER AIRBAG (PAB) SWITCH.....	113
11.8	POWER MIRROR SWITCH .....	114
11.9	BONNET SWITCH .....	116
11.10	HEAD LAMP ROTARY SWITCH.....	117
11.11	HAND BRAKE SWITCH.....	119
<b>12</b>	<b>WINDOW WINDING CONTROLLER</b> .....	<b>120</b>
<b>13</b>	<b>BODY CONTROL MODULE (BCM)</b> .....	<b>124</b>
<b>14</b>	<b>IMMOBILIZER SYSTEM</b> .....	<b>150</b>
<b>15</b>	<b>DIAGNOSTIC USER MANUAL</b> .....	<b>155</b>

### PART B

<b>16</b>	<b>CIRCUIT SCHEMATICS</b> .....	
<b>17</b>	<b>WIRING HARNESS FITMENT DRAWING</b> .....	
<b>18</b>	<b>DTC (DIAGNOSTIC TROUBLE CODES)</b> .....	

---

---

b. When disconnecting a connector pull it off from the mating connector by holding on both connectors. Never try to disconnect connectors by pulling on their wires.

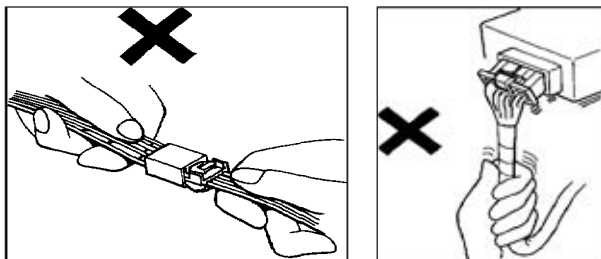
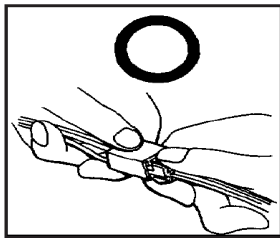

c. While disconnecting the interconnection connector, press in the direction indicated by arrows in the illustration.

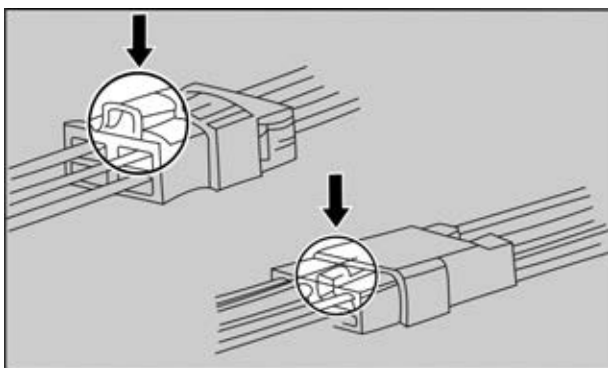

d. While connecting the interconnection connectors, insert the connectors until a “snap” noise is heard.

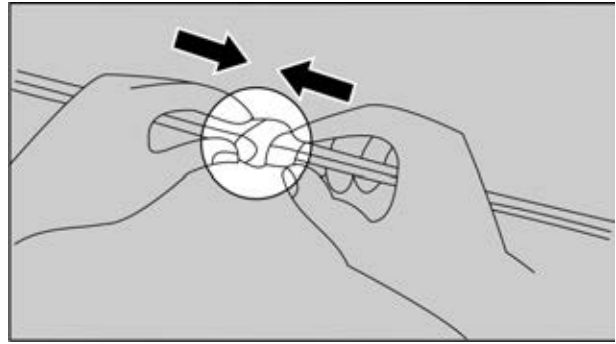

e. Dirt / corroded terminals result in improper contact. The terminals should be cleaned carefully. Improper contact pressure between mating terminals disturbs the connectivity between them. Replace the damaged connector body to avoid exposure of the terminals in case of inadequate contact pressure.

Ensure proper connection between the terminals to the wire. Rectify the loose connection by repairing / replacing the wire harness. Worn out insulation of the wire may result in short circuit. Avoid water entering in the connectors.

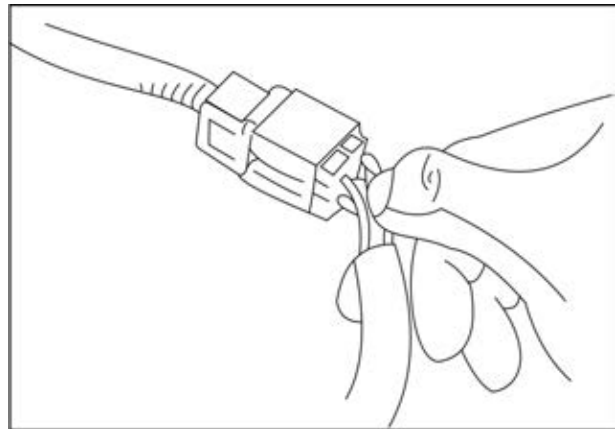

10. Before removing a faulty component, refer to the Workshop Manual for removal procedures. Ensure the starter switch is turned to the 'OFF' position, the battery is disconnected and any disconnected harnesses are supported to avoid any undue strain at terminals. When replacing the component keep oily hands away from electrical connection areas and push connector's home until any locking tabs fully engage.

### REMOVAL:

1. Remove the air filter assembly; (*Refer Air filter assembly removal process*).
2. Disconnect the electrical connections of the starter motor.
3. Loosen and remove the 3 mounting bolts (1) and remove the starter motor (2).

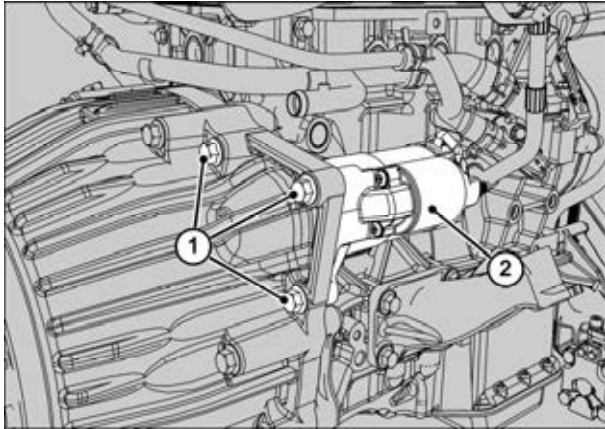

### DISMANTLING:

1. Clamp the starter motor by its 'eye' on a vice. Unscrew nut on the solenoid and remove the supply terminal. Loosen the three fastening screws from the solenoid and remove the solenoid. Remove the armature and return spring.

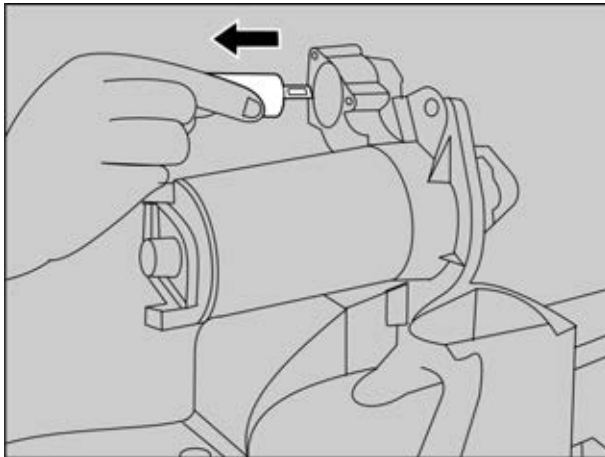

2. Loosen screws on the rear closing cap but do not remove yet.

3. Unscrew through bolts. Mount the starter motor vertically on the vice. Remove stator frame with closure cap, armature and commutator end shield from the drive end housing.

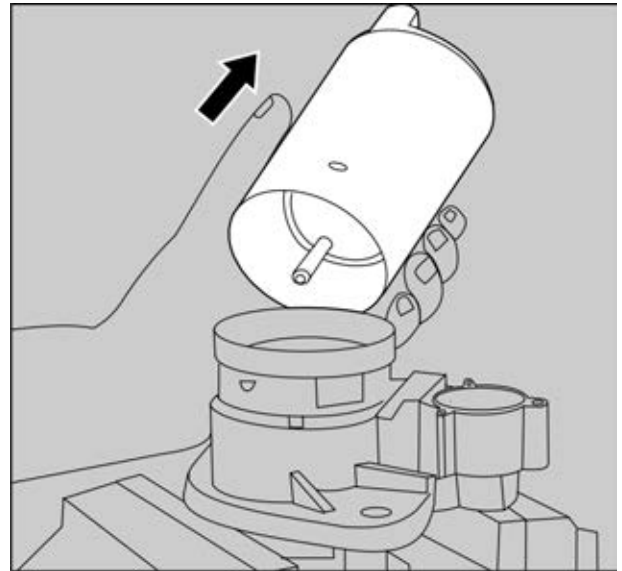

4. Unscrew screws and remove closure cap from commutator end shield. Remove retaining (lock) washer and shims from armature shaft. Remove commutator end shield.
5. Insert tool H-S/KDEP188 onto the armature shaft and slide the brush plate on to the tool. Pull the tool with the brush plate off the armature shaft.
6. Pullout the armature from the stator frame.

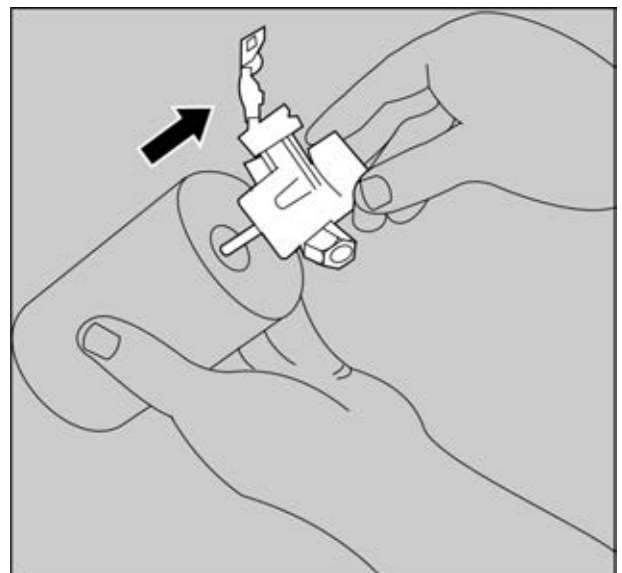

## ELECTRICAL

### 4.16 REVERSE INDICATOR LAMP

The fog lamp is located in the lower part of the rear corner LH. The bulb used for the fog lamp function is 12V, 21W. Fog lamp on/off is done by using head lamp rotary switch.

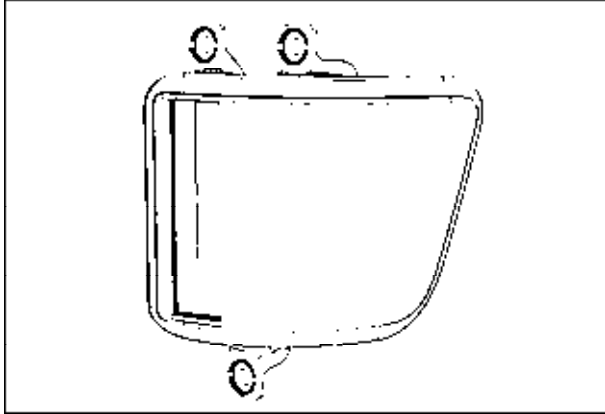

#### LOCATION:

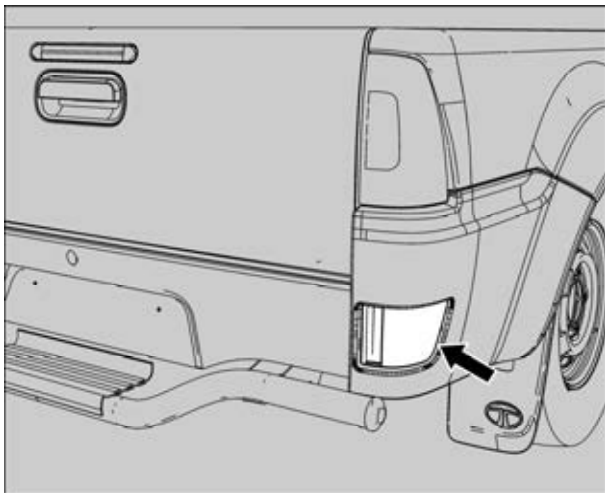

#### REMOVAL:

1. Disconnect the electrical connection of fog lamp.

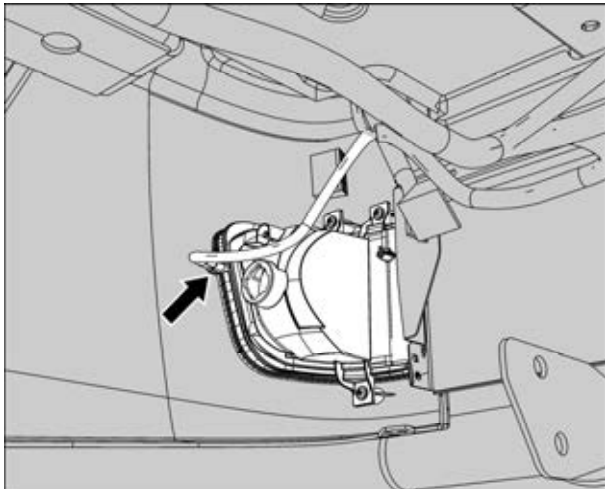

2. From the back side of rear corner assembly remove the 3 mounting screws of fog lamp.

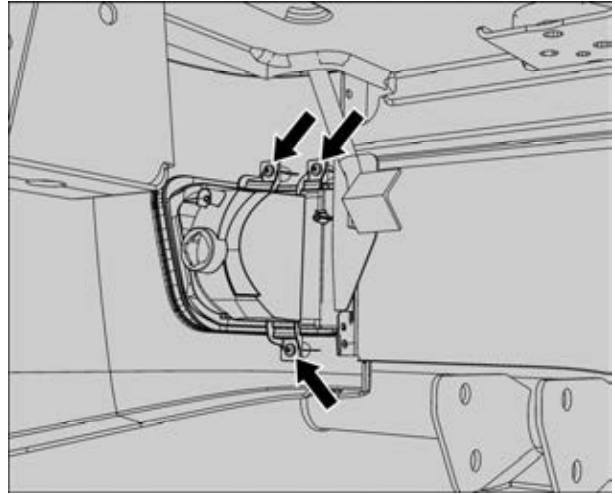

3. Take out the fog lamp.

#### REFITMENT:

1. Fit the assembly in the cut out on the rear corner assembly LH.
2. Tighten the 3 mounting screws of fog lamp assembly.

Tightening torque for screws – 0.6 kgfm.

3. Connect the electrical connection.

#### BULB REPLACEMENT PROCEDURE:

1. Remove the rear fog lamp assembly.
2. Remove the bulb assembly by rotating in anticlockwise direction.
3. Take out the bulb from holder and replace with new one.
4. Fit the assembly by rotating in clockwise direction.
5. Fit the rear fog lamp assembly.

HEAD LIGHT AND FLICK WASH OPERATION:

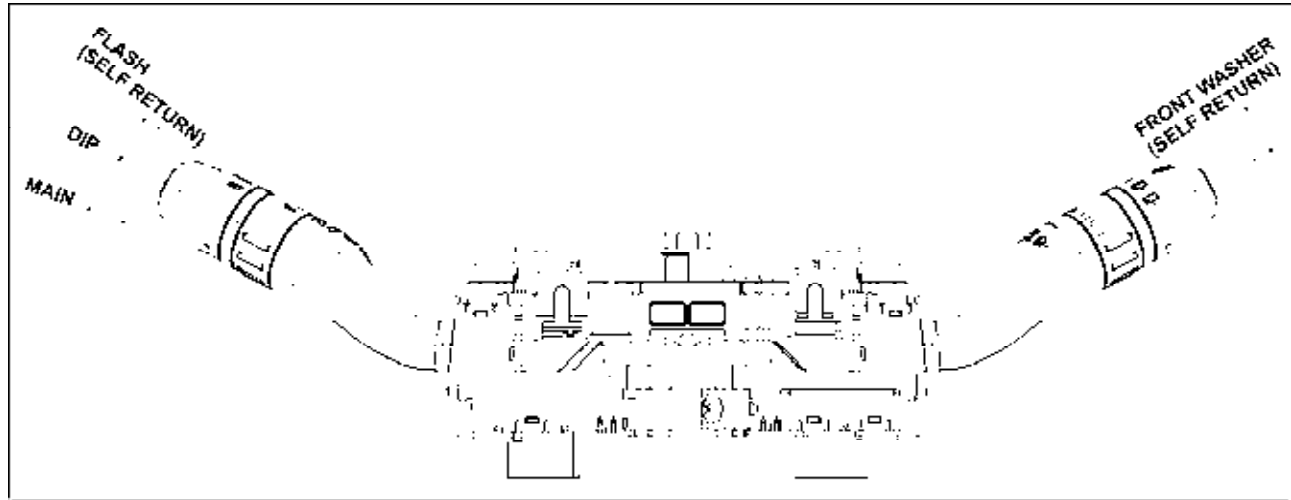

CONNECTOR DETAILS:

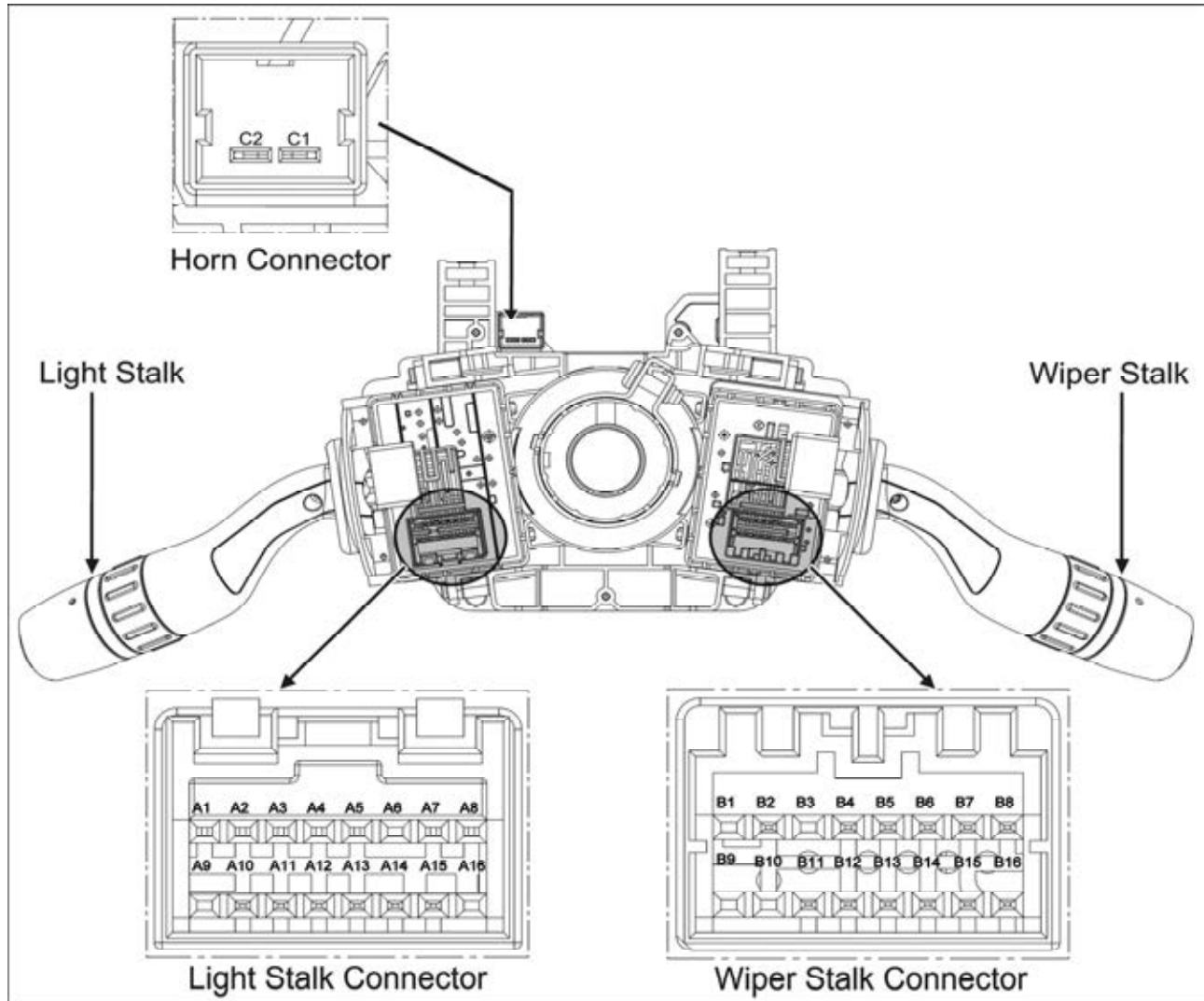

## ELECTRICAL

### 11.9 BONNET SWITCH

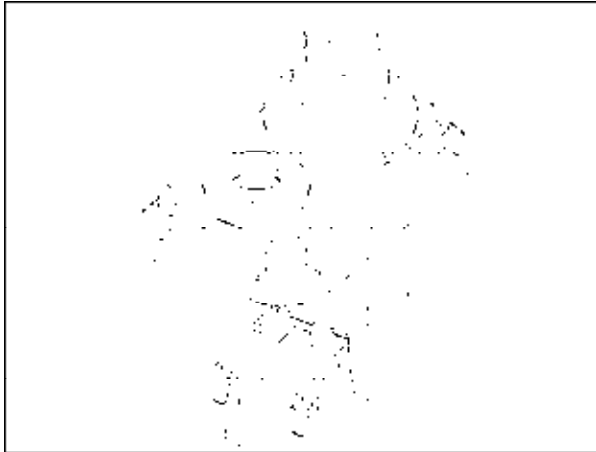

#### FUNCTION:

Bonnet switch is switched on or off in response to opening and closing of bonnet.

#### LOCATION:

It is fitted on Assembly Panel outer RH.

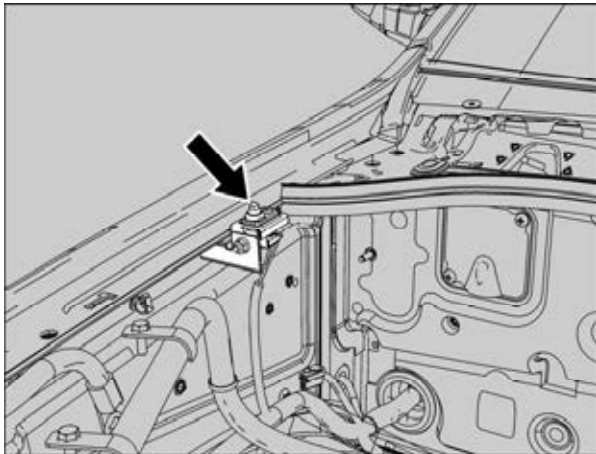

#### REMOVAL:

1. Open the bonnet and disconnect the electrical connection of bonnet switch.

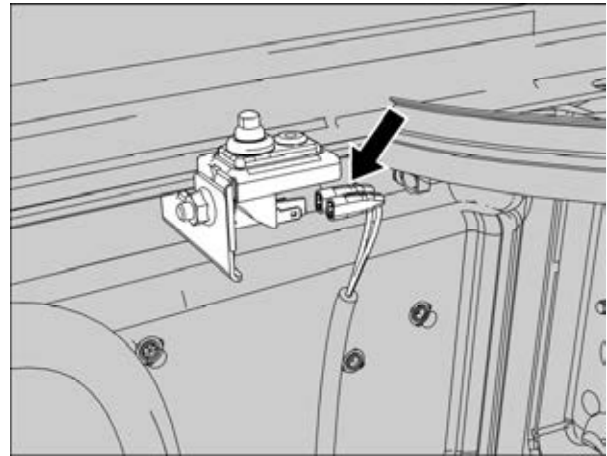

2. Remove one mounting screw of bonnet switch and take out the switch.

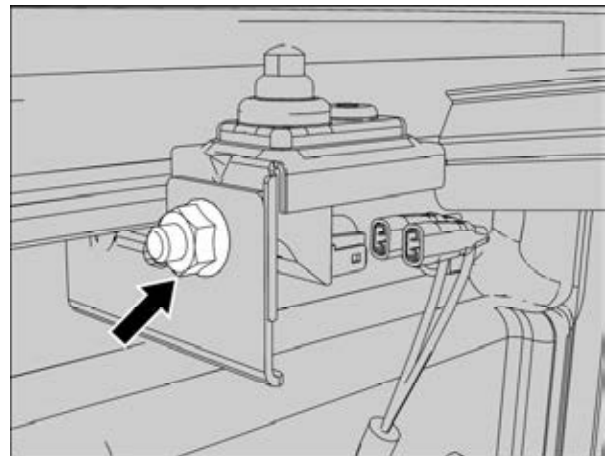

#### REFITMENT:

1. Fit the bonnet switch on the bracket.
2. Tighten the mounting screw.  
Tightening torque for screw – 0.95 Kgm
3. Connect the electrical connection to the bonnet switch.

## ELECTRICAL

### PINOUT DETAILS OF 48 PIN CONNECTOR:

PIN. NO.	SIGNAL DESCRIPTION	SIGNAL TYPE	ACTIVE LEVEL
X1. A1	Spare High Input	DI	High
X1. A2	Dip / Low beam Switch	DI	Low
X1. A3	Tick Tock Relay	DO	High
X1. A4	High / Main Beam Relay	DO	High
X1. B1	Parking/Side Light Switch	DI	High
X1 .B2	V Batt		
X1. B3	Key In Switch	DI	High
X1. B4	Hazard Warning LED (Not Applicable)	DO	High
X1. C1	Spare High Input	DI	High
X1. C2	Left Turn Switch	DI	Low
X1. C3	Right Turn Switch	DI	Low
X1. C4	Key Ring Illumination Output	PWM	High
X1. D1	Hazard Warning Switch	DI	Low
X1. D2	Can High (Not Applicable)	CAN	
X1. D3	Can Low (Not Applicable)	CAN	
X1. D4	Spare LC Low Side output	DO	Low
X1. E1	Front Wiper Intermittent Fault	DI	Low
X1. E2	Front Wash Switch	DI	Low
X1. E3	Ground		
X1. E4	Buzzer	DI	Low
X1. F1	Spare Low Input	DI	Low
X1. F2	V Batt		
X1. F3	Spare LC Low Side output	DO	Low
X1. F4	Daytime Running Light	Do	High
X1. G1	Rear Fog Lamp Switch	DI	High
X1. G2	Spare K Line		
X1. G3	Engine RPM	PWM	Pull Up to 5V
X1. G4	Front Wiper Intermittent Setting	AI	
X1.H1	Co-Driver Door Switch	DI	Low
X1.H2	Driver Door Switch	DI	Low
X1.H3	Rear Left Door Switch	DI	Low
X1.H4	Main High Beam Switch	DI	Low
X1. J1	Rear Right Door Switch	DI	Low
X1. J2	Inertia Signal From ACU	DI	Low
X1. J3	Spare Analog Input	AI	
X1. J4	Bonnet Switch	DI	Low
X1. K1	Diagnostic K Line		

## ELECTRICAL

### 7. DIAGNOSTIC TROUBLESHOOTING TABLE FOR BOTH EMS & ICU, WITH DTCS

Following chart has useful information, under different operating conditions, which may occur on vehicle. This is valid for TATA XENON E - V EMS ECU

NO	SCENARIO ( <i>BETWEEN IMMO &amp; EMS</i> )	DTC CODES		STATUS LAMP ( <i>"LOCK" SYMBOL</i> )		VEHICLE STARTING	REMARKS
		EMS	IMMO	IGN OFF	IGN ON		
1.	CAN_H wire open circuit	IVN DTCs	-	Blink	OFF	No	NO_RESPONSE and CAN_MUTE error
2.	CAN_L wire open circuit	IVN DTCs	-	Blink	OFF	No	NO_RESPONSE and CAN_MUTE error
3.	CAN_H & CAN_L wires swapped	IVN DTCs	-	Blink	OFF	No	CAN_OFF and CAN_MUTE error
4.	CAN_H & CAN_L short	IVN DTCs	-	Blink	OFF	No	CAN_OFF and CAN_MUTE error
5.	Both CAN_H & CAN_L open	IVN DTCs	-	Blink	OFF	No	Service Lamp come ON
6.	No battery supply to ICU	-	P0560 P0562	OFF	OFF	Yes	No degradation in Immo function
7.	No Ignition supply to ICU	U0167	-	Blink	Blink	No	Service Lamp come ON
8.	No Ground connection to ICU	U0167	P0560 P0562	OFF	OFF	No	Service Lamp come ON
9.	Different AES key code in EMS & ICU	U0426	U0401	Blink	ON	No	-
10.	Battery supply < 8V	U0426	P0560 P0562	Blink	OFF	No	-
11.	Battery supply > 16V	U0426	P0560 P0563	Blink	OFF	No	-
12.	Mechanical key ( <i>without transponder</i> )	P0513	B1343	Blink	ON	No	-
13.	Wrong E-key ( <i>mismatch of transponder &amp; code in ICU</i> )	P0513	B1342/ P0513	Blink	ON	No	-
14.	Immobilizer unit not connected	U0167	-	OFF	OFF	No	Service Lamp come ON

After filling data use will get Form which have embedded CSV file which is saved recently. Also this form contains list of all files present with saving folder for DTC file.

The screenshot displays the 'TML Vehicle Diagnostics' application window. The title bar reads 'TML Vehicle Diagnostics For BCM Xenon Euro V'. The interface is divided into several sections:

- Left Panel (SERVICES):** Contains buttons for 'ECU Identification Data', 'Read ECU Parameters', 'Read DTCs', 'Input/Output Control', and 'Write'.
- Top Panel:** Includes a menu bar (File, Services, View, Help) and a toolbar with play, stop, and close icons.
- Main Area:**
  - A prompt: 'Please select any file to view details'.
  - A table with columns: 'Select File', 'File Name', and 'Created On(DD/MM/YYYY)'.
 

Select File	File Name	Created On(DD/MM/YYYY)
<input checked="" type="checkbox"/>	00000000000000000000_16-03-2012_9-21-42.csv	16/03/2012 9:21:50 AM
<input type="checkbox"/>	866868769869_06-03-2012_15-11-50.csv	06/03/2012 3:11:54 PM
<input type="checkbox"/>	00000000000000000000_06-03-2012_14-38-25.csv	06/03/2012 2:38:28 PM
  - A data entry form with a dropdown menu set to 'A1' and a search field for 'Vehicle Name'. Below is a grid with columns A-J and rows 1-16.
 

	A	B	C	D	E	F	G	H	I	J
1	Vehicle Name	Xenon Euro V								
2										
3	Part no	-								
4										
5	VIN	-								
6										
7	Vehicle nu	-								
8										
9	OdoMeter	-								
10										
11	Employee	-								
12										
13	Role :	-								
14										
15	Shift :	-								
16										
  - Buttons at the bottom: 'Delete Selected', 'Delete All', 'Save As', and 'Close'.
- Bottom Panel (Message Panel):** Displays the message 'Initialisation successful, Execute any other commands.' and the date '16/03/2012'.

### 2.5.4 SERVICES PANEL

On successful communication the Services Panel will be visible to the user which will cater the services supported by the ECU.

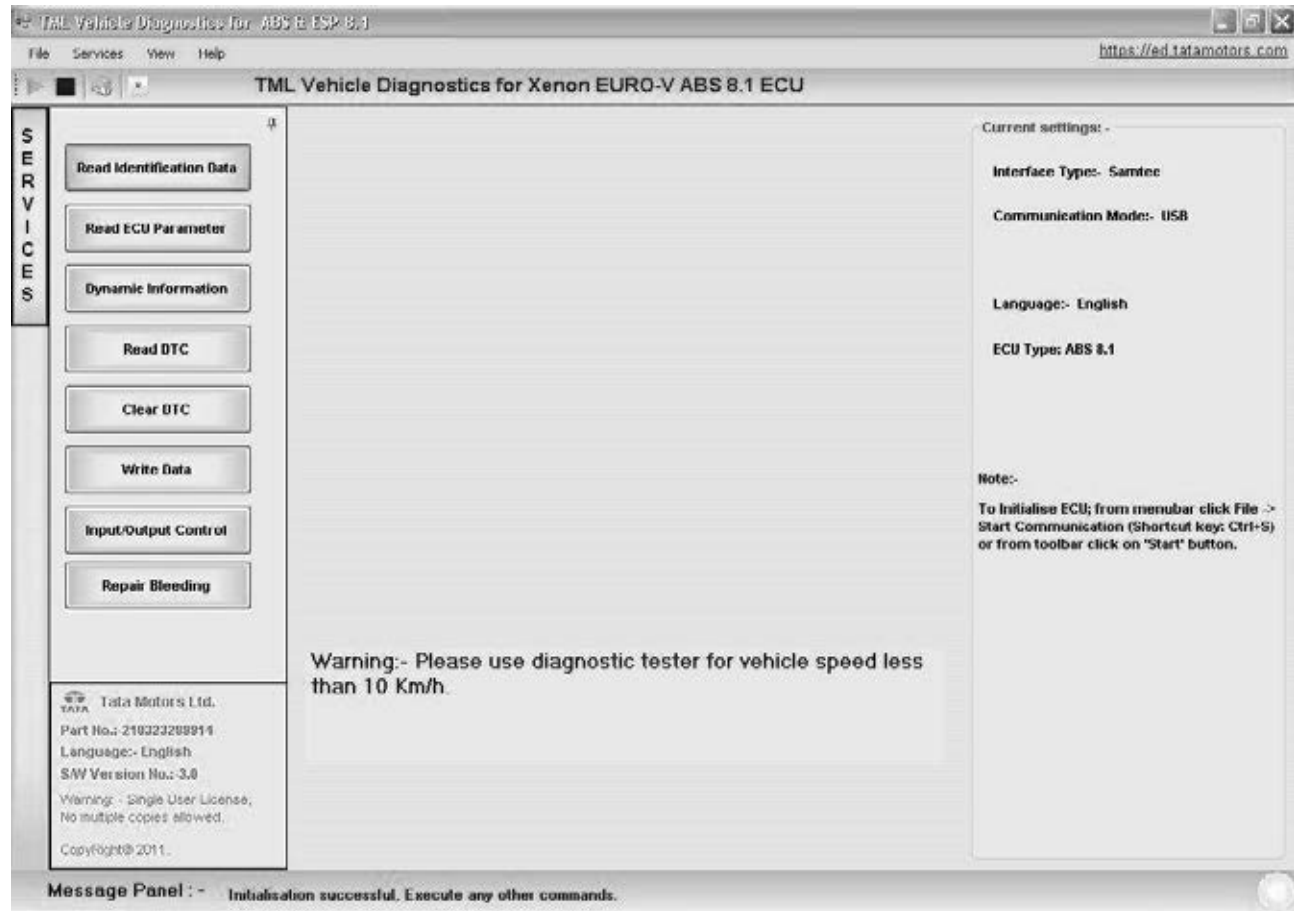

Click on the service buttons to execute the corresponding service. Auto hide button for services panel can be used to have bigger preview area for displayed results.



EXTERIOR LIGHTING

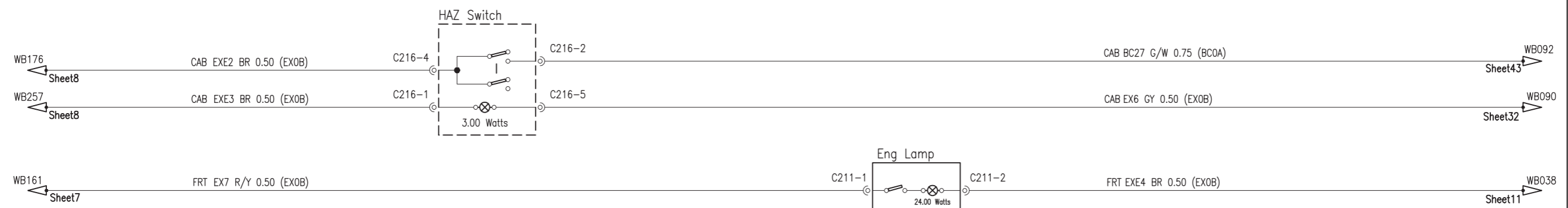
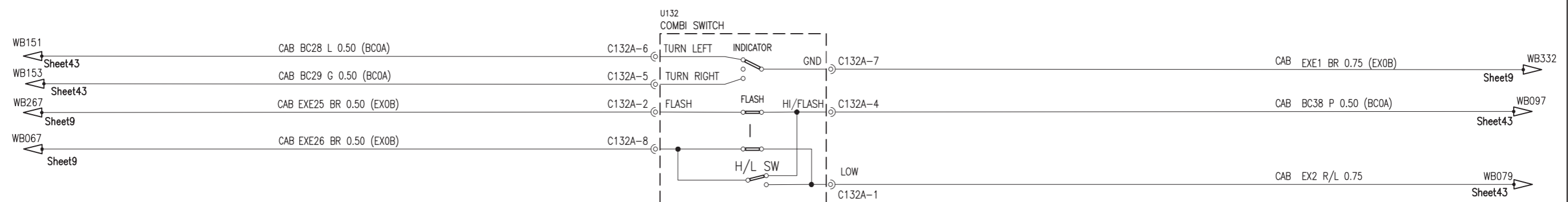

SYSTEM CODE	EX0B
SYSTEM NAME	EXTERIOR LIGHTING
SHEET NO.	SHEET 31



## INFO. FITMENT DRG. FOR ROOF W/H

STEP NO.1

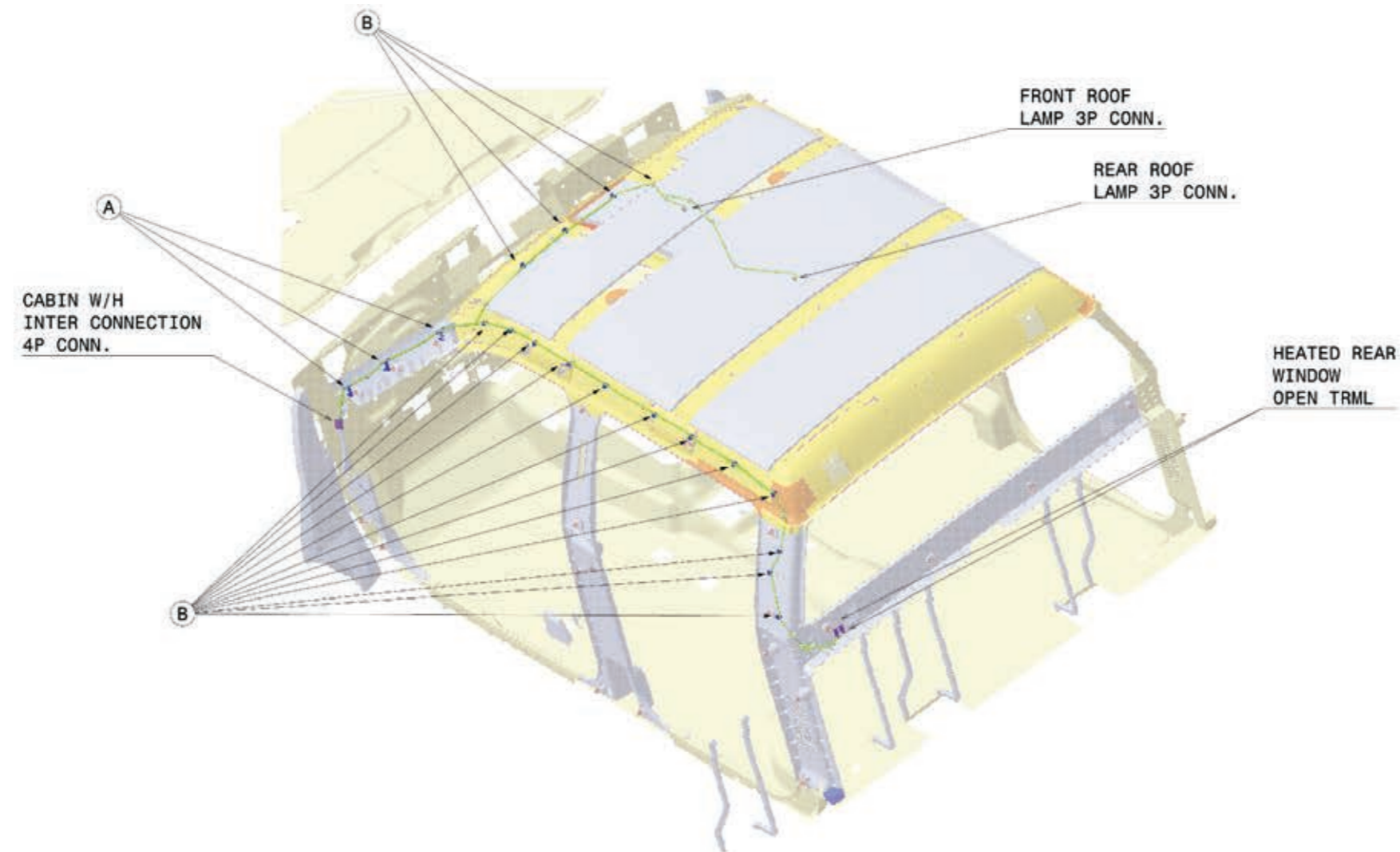

- 1) LAY DOWN THE WIRING HARNESS ON THE ROOF OF THE CAB.
- 2) CONNECT THE INTERCONNECTION OF CABIN W/H AND THEN CLAMP CLIPS TO ROUTE WIRING HARNESS ON CAB ROOF.
- 3) CONNECT THE FRONT ROOF LAMP, REAR ROOF LAMP AND HEATED REAR WINDOW CONNECTION TO COMPLETE THE ROUTING OF ROOF WIRING HARNESS.



AFTER COMPLETION CHECK THE ENTIRE WIRING HARNESS AND ITS ROUTING TO ENSURE THAT WIRING HARNESS IS FITTED PROPERLY TO MAINTAIN ZERO DEFECT.

## NOTE:

- 1) ALL THE CLAMPS CLAMPED PROPERLY ON MARKED LOCATIONS.
- 2) HARNESS SHOULD NOT BE COME IN CONTACT WITH MOVING AND HOT PARTS.
- 3) ADDITIONAL CLAMPS AND CABLE TIE CAN BE USED IF REQUIRED.
- 4) AT THE TIME OF CONN & DISCONN. OF CONNECTORS MAKE SURE PULL ONLY CONNECTORS NOT THE WIRING HARNESS.

DRG / PART NO.	2894 5460 00 07
SHEET NO.	7

## ELECTRICAL

DTC CODE	DTC DESCRIPTION	FTB NUMBER	CAUSES	REMEDIES	COMMENTS
P042A	Catalyst Temperature Sensor Circuit, Bank 1, Sensor 2	2F	This DTC gets logged If the difference between the filtered temperature value(first order filter used inside the EMS ECU for filtering sensor input) and raw temperature value from sensor is greater than some calibrated maximum threshold value due to noise	<ol style="list-style-type: none"> <li>1. Check the continuity between the EMS ecu pins A06 &amp; A23 to the DOC temp out sensor connector pins. Rectify if any issues found.</li> <li>2. Check wiring harness connections between the EMS ecu and the DOC temp out sensor and rectify if any wrong connections/splices are found.</li> <li>3. Check whether the DOC temp out sensor signal pin A06 is Short circuited to battery. If So, rectify the wiring harness connections of DOC temp out sensor.</li> <li>4. Check for rust/dirt on the sensor connector. If any dirt/rust found then clean and refit the connector.</li> <li>5. Check for any damage on EMS ecu pins and Sensor connector pins.</li> <li>6. Replace the sensor if the problem still persists.</li> <li>7. Replace the EMS ecu if the problem still persists.</li> </ol>	
P060B	Internal Control Module A/D Processing Performance	49	This DTC gets logged due to the failure in Analog digital converter of EMS ECU	<ol style="list-style-type: none"> <li>1. Check for any physical damage of EMS ECU pins, if found then replace EMS ECU.</li> <li>2. Check for proper ground connection of EMS ECU; if any issue is found then rectify wiring harness connection.</li> <li>3. Check whether the software flashed in the vehicle is late</li> </ol>	
P042A	Catalyst Temperature Sensor Circuit, Bank 1, Sensor 2	62	This fault gets logged if The absolute difference between real After-DOC temperature and estimated raw After-DOC temperature is not below a calibrated threshold value in normal Engine operating condition.	<ol style="list-style-type: none"> <li>1. Check the continuity between the EMS ecu pins A06 &amp; A23 to the DOC temp out sensor connector pins. Rectify if any issues found.</li> <li>2. Check wiring harness connections between the EMS ecu and the DOC temp out sensor and rectify if any wrong connections/splices are found.</li> <li>3. Check whether the DOC temp out sensor signal pin A06 is Short circuited to battery. If So, rectify the wiring harness connections of DOC temp out sensor.</li> <li>4. Check for rust/dirt on the sensor connector. If any dirt/rust found then clean and refit the connector.</li> <li>5. Check for any damage on EMS ecu pins and Sensor connector pins.</li> <li>6. Replace the sensor if the problem still persists.</li> <li>7. Replace the EMS ecu if the problem still persists.</li> </ol>	
P2002	Particulate Filter Efficiency Below Threshold	7A	If the DPF is leaking somehow, the differential pressure or normalized differential pressure (soot ash index) would drop to values smaller than the pressure drop of a clean new filter in some cases (i.e. after regeneration). If the soot ash index drops b	<ol style="list-style-type: none"> <li>1. Check for any physical damages of DPF, which is leading to DPF leaking.</li> <li>2. If possible, seal the DPF leak area else replace with a new DPF (Leak before the filter or on the filter itself).</li> <li>3. Try to perform filter regeneration : warm engine (5min) then launch regeneration cycle and drive necessary time</li> <li>4. Replace DPF if problem still persists. Replace the EMS ecu if the problem still persists.</li> </ol>	
P249F	Excessive Time To Enter Closed Loop Particulate Filter Regeneration Control	00	This fault is a grouping fault for the following faults P2002-95,P2463-97	<ol style="list-style-type: none"> <li>1. As this fault logs along with any of the faults- P2002-95, P2463-97.</li> <li>2. Follow the rectification procedure of any of the above faults for resolving this fault.</li> </ol>	
P2002	Diesel Particulate Filter Efficiency Below Threshold	95	This fault gets logged if the inlet and outlet pipe/tube connections of Delta pressure sensor are reversed	<ol style="list-style-type: none"> <li>1. Check the correctness of Inlet and outlet pipe/tube mechanical connections of Delta pressure sensor.</li> <li>2. Rectify the mechanical connections if any issue is found.</li> <li>3. Try to perform filter regeneration : warm engine (5min) then launch regeneration cycle and drive necessary time</li> <li>4. Replace the EMS ecu if the problem still persists.</li> </ol>	

DTC CODE	DTC DESCRIPTION	FTB NUMBER	CAUSES	REMEDIES	COMMENTS
P2A50	Fuel Injector Group "B" Supply Voltage Circuit Low	11	1. This fault will get logged if either HSD of injectors in cylinders 3 & 4 are Short circuited to GND.	<p>1 Check Injector Connection; Switch ignition off and wait for ten seconds. Remove injector connector; clean and reconnect properly.</p> <p>2 Check Injector electrical continuity between ECU and Injector connector as per circuit schematic; if required correct or replace the harness. Check whether the EMS ecu pins A51 &amp; A03 (HSD's of injector cylinder 3 &amp; 4) pins are short circuited to ground, If so then replace the wiring harness connections.</p> <p>3. Check continuity using a multi meter across injector pins. Replace injector if found faulty.</p> <p>4. Check ecu pins and connector pins for damage.</p> <p>5. Check ECU; replace ECU, if problem still persists.</p> <p>6. After rectification ensure the following before handing over to customer.</p> <p>a) Please fit the injector with its connector on wiring harness and remove ECU connector and check for continuity between injector and the ECU connector.</p> <p>b) Perform actuator test for the injectors.</p>	
PB148	Fuel Injector Group "A" Supply Voltage Circuit High	12	1. This fault will get logged if either HSD of injectors in cylinders 1 & 2 are Short circuited to VBATT.	<p>1 Check Injector Connection; Switch ignition off and wait for ten seconds. Remove injector connector; clean and reconnect properly.</p> <p>2 Check Injector electrical continuity between ECU and Injector connector as per circuit schematic; if required correct or replace the harness. Check whether the EMS ecu pins A27 &amp; A50 (HSD's of injector cylinder 1 &amp; 2) pins are short circuited to ground, If so then replace the wiring harness connections.</p> <p>3. Check continuity using a multi meter across injector pins. Replace injector if found faulty.</p> <p>4. Check ecu pins and connector pins for damage.</p> <p>5. Check ECU; replace ECU, if problem still persists.</p> <p>6. After rectification ensure the following before handing over to customer.</p> <p>a) Please fit the injector with its connector on wiring harness and remove ECU connector and check for continuity between injector and the ECU connector.</p> <p>b) Perform actuator test for the injectors.</p>	
P2A51	Fuel Injector Group "B" Supply Voltage Circuit High	12	1. This fault will get logged if either HSD of injectors in cylinders 3 & 4 are Short circuited to Battery.	<p>1 Check Injector Connection; Switch ignition off and wait for ten seconds. Remove injector connector; clean and reconnect properly.</p> <p>2 Check Injector electrical continuity between ECU and Injector connector as per circuit schematic; if required correct or replace the harness. Check whether the EMS ecu pins A51 &amp; A03 (HSD's of injector cylinder 3 &amp; 4) pins are short circuited to ground, If so then replace the wiring harness connections.</p> <p>3. Check continuity using a multi meter across injector pins. Replace injector if found faulty.</p> <p>4. Check ecu pins and connector pins for damage.</p> <p>5. Check ECU; replace ECU, if problem still persists.</p> <p>6. After rectification ensure the following before handing over to customer.</p> <p>a) Please fit the injector with its connector on wiring harness and remove ECU connector and check for continuity between injector and the ECU connector.</p> <p>b) Perform actuator test for the injectors.</p>	

DTC	DESCRIPTION	CAUSES	EFFECT	CHECK POINTS	CORRECTIVE ACTION
B1309	Horn Relay Short to Ground/Open	1) Horn Relay output is short to ground. 2) Open circuit between BCM & Horn relay. 3) BCM mating connector is not connected firmly. Horn relay is faulty.	In case of short to ground Horn relay will remain Continuously operated (Horn will cont. operated with out pressing the horn pad) and During open circuit the horn relay will remain Continuously OFF.	1) Check the physical connection of the BCM connector & the Horn relay on its mounting relay. 2) Turn off ignition and unplug BCM X2 connector. Check continuity between BCM connector pin no X2.D1 to horn relay coil terminal connector pin. If continuity not found then refer corrective action 2. Then plug BCM X2 connector. 3) Turn off ignition and unplug BCM X2 connector. Check for continuity between BCM pin no X2.D1 with Vehicle ground. If continuity found correct the wiring harness. Refer corrective action 3. 4) Check the continuity between the two terminals of relay coil. If the continuity not found then refer the corrective action 4. 5) Check the terminal insertion for BCM connector & Horn relay wire insertion. 6) Switch On the ignition & Clear DTC. 7) Turn OFF the Horn Relay then turns ON the Horn Relay. 8) Read DTC.	1) Connect the BCM connector firmly & properly fit the Horn Relay on relay mounting base. 2) If there is no continuity correct the wiring harness. 3) If there is continuity correct the wiring harness (remove the wiring harness short to Ground). 4) Replace the relay with new one. 5) Check the relay terminals insertions & BCM wiring insertion.
B1308	Horn Relay Short to Battery	1) Horn relay is short to Battery. 2) Horn relay is faulty.	Horn relay will remain Continuously OFF.	1) Turn off ignition and unplug BCM X2 connector. Check if any 12 V supply is seen across pins X2.D1 If 12 V found across pins X2.D1 correct the wiring harness. Refer corrective action. Then plug BCM X2 connector. 2) Switch On the ignition & Clear DTC. 3) Turn OFF the Horn Relay then turns ON the Horn Relay. 4) Read DTC.	Correct the wiring harness (remove the BCM pin X2.D1 short to vehicle battery).