

## 1. Basic Diagnostic Procedure

### A: BASIC PROCEDURES

#### 1. GENERAL DESCRIPTION

The most important purpose of diagnostics is to determine which part is malfunctioning quickly, to save time and labor.

#### 2. IDENTIFICATION OF TROUBLE SYMPTOM

Determine what the problem is based on the symptom.

#### 3. PROBABLE CAUSE OF TROUBLE

Look at the wiring diagram and check system's circuit. Then check the switch, relay, fuse, ground, etc.

#### 4. LOCATION AND REPAIR OF TROUBLE

- 1) Using the diagnostics, narrow down the causes.
- 2) If necessary, use a voltmeter, ohmmeter, etc.
- 3) Before replacing certain component parts (switch, relay, etc.), check the power supply, ground, for open wiring harness, poor connectors, etc. If no problems are encountered, check the component parts.

#### 5. CHECK SYSTEM OPERATION

After repairing, ensure that the system operates properly.

### B: BASIC INSPECTION

#### 1. VOLTAGE MEASUREMENT

- 1) Using a voltmeter, connect the negative lead to a good ground point or negative battery terminal and the positive lead to the connector or component terminal.
- 2) Contact the positive lead of the voltmeter on connector (A). The voltmeter will indicate a voltage.
- 3) Shift the positive lead to connector (B). The voltmeter will indicate no voltage.

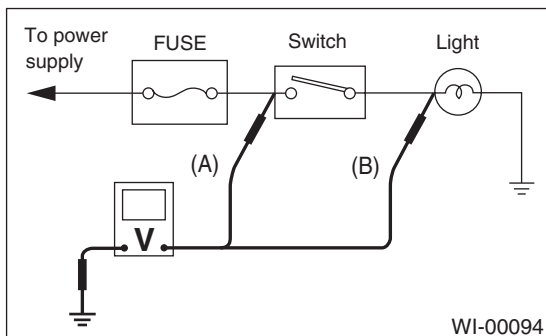

- 4) With the test set-up held as it is, turn the switch ON. The voltmeter will indicate a voltage and, at the same time, the light will come on.

- 5) The circuit is in good order. If a problem such as a light failing to illuminate occurs, use the procedures outlined above to track down malfunction.

#### 2. CIRCUIT CONTINUITY CHECKS

- 1) Disconnect the battery terminal or connector so there is no voltage between check points. Contact the two leads of an ohmmeter to each of the check points.

If the circuit has diodes, reverse the two leads and check again.

- 2) Use an ohmmeter to check for the diode continuity. When contacting the negative lead to diode positive side and positive lead to negative side, there should be continuity.

When contacting the two leads in reverse, there should be no continuity.

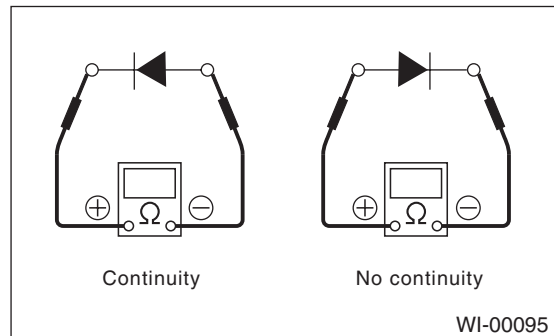

- 3) Symbol "○ — ○" indicates that continuity exists between two points or terminals. For example, when a switch position is at "3", continuity exists among terminals 1, 3 and 6, as shown in table below.

Terminal Switch Position	1	2	3	4	5	6
OFF						
1	○ — ○				○ — ○	
2	○ — ○			○ — ○		○ — ○
3	○ — ○		○ — ○			○ — ○
4	○ — ○	○ — ○				○ — ○

WI-00096

# Power Supply Circuit

WIRING SYSTEM

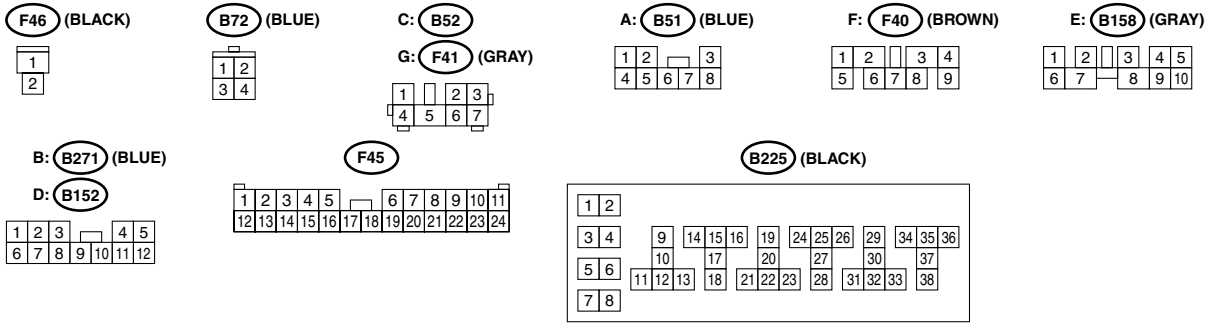
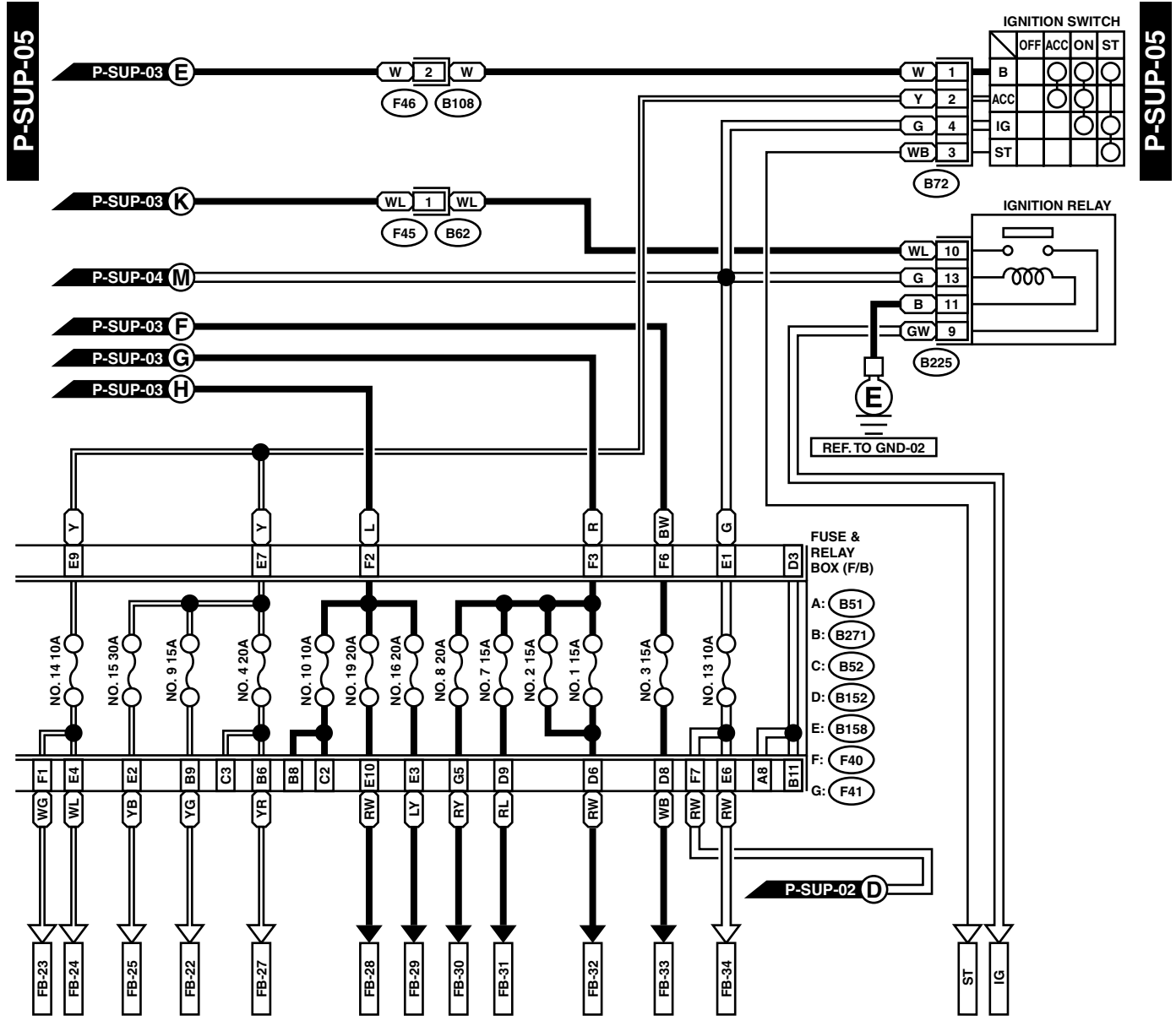

WI-08870

# Power Supply Circuit

WIRING SYSTEM

No.	Load
MB-1	A/C relay holder (Fuse) Secondary A/C relay holder
MB-2	Combination meter Headlight RH
MB-3	Headlight LH
MB-4	Horn
MB-5	Cruise control switch Horn switch Keyless entry control module Security horn relay
MB-6	Hazard switch Ignition starter and steering lock assembly Keyless entry control module
MB-7	TCM Driver's control center differential relay Driver's control center differential control module
MB-8	Daytime running light control module Diode (Daytime running light)
MB-9	Data link connector ECM Fuel pump relay Main relay Electronic throttle control relay Immobilizer control module
MB-10	Keyless buzzer
MB-11	Fuse (Seat heater)
MB-12	Power window circuit breaker
MB-13	Relay holder
SBF-8	ABS control module
IG	Hazard switch Power window relay
ST	Interrupt relay
FB-1	Combination meter Hazard switch Rear turn signal light RH Trailer connector Turn signal switch Keyless entry control module
FB-2	Combination meter Hazard switch Rear turn signal light LH Trailer connector Turn signal switch Keyless entry control module
FB-3	Parking switch
FB-4	Front turn signal light RH
FB-5	Front turn signal light LH
FB-6	Front clearance light LH Front clearance light RH Headlight leveler LH Headlight leveler RH
FB-7	License plate light Rear combination light LH Rear combination light RH Trailer connector

No.	Load
FB-8	Clock Auto A/C control module Combination meter Ignition starter and steering lock assembly Keyless entry control module Radio Room light Spot map light
FB-9	Clock Combination meter Illumination light Body integrated module Headlight leveler switch HID relay
FB-10	Parking switch
FB-11	ECM Lighting switch
FB-12	Parking switch
FB-13	Mirror heater relay Rear defogger Rear defogger switch Auto A/C control module
FB-14	Body integrated module ECM
FB-15	ABS control module Back-up light switch (MT) Data link connector Cruise control switch ECM Daytime running light control module Daytime running light relay High-beam relay Keyless entry control module Impact sensor Vehicle speed sensor (MT) Wiper deicer relay Wiper deicer timer Stop light and brake switch Cruise clutch switch (MT)
FB-16	Main fan relay-1 Main fan relay-2
FB-17	A/C relay Sub fan relay-1 Sub fan relay-2 A/C pressure switch
FB-18	A/C switch Auto A/C control module Blower fan motor relay Illumination light

# Engine Electrical System

WIRING SYSTEM

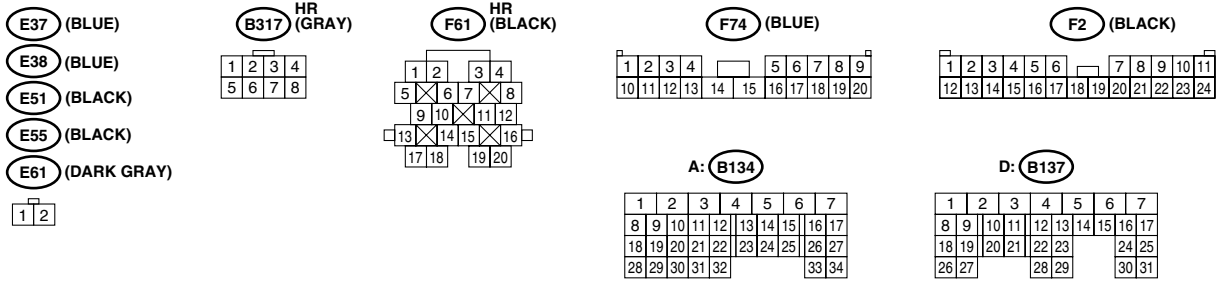
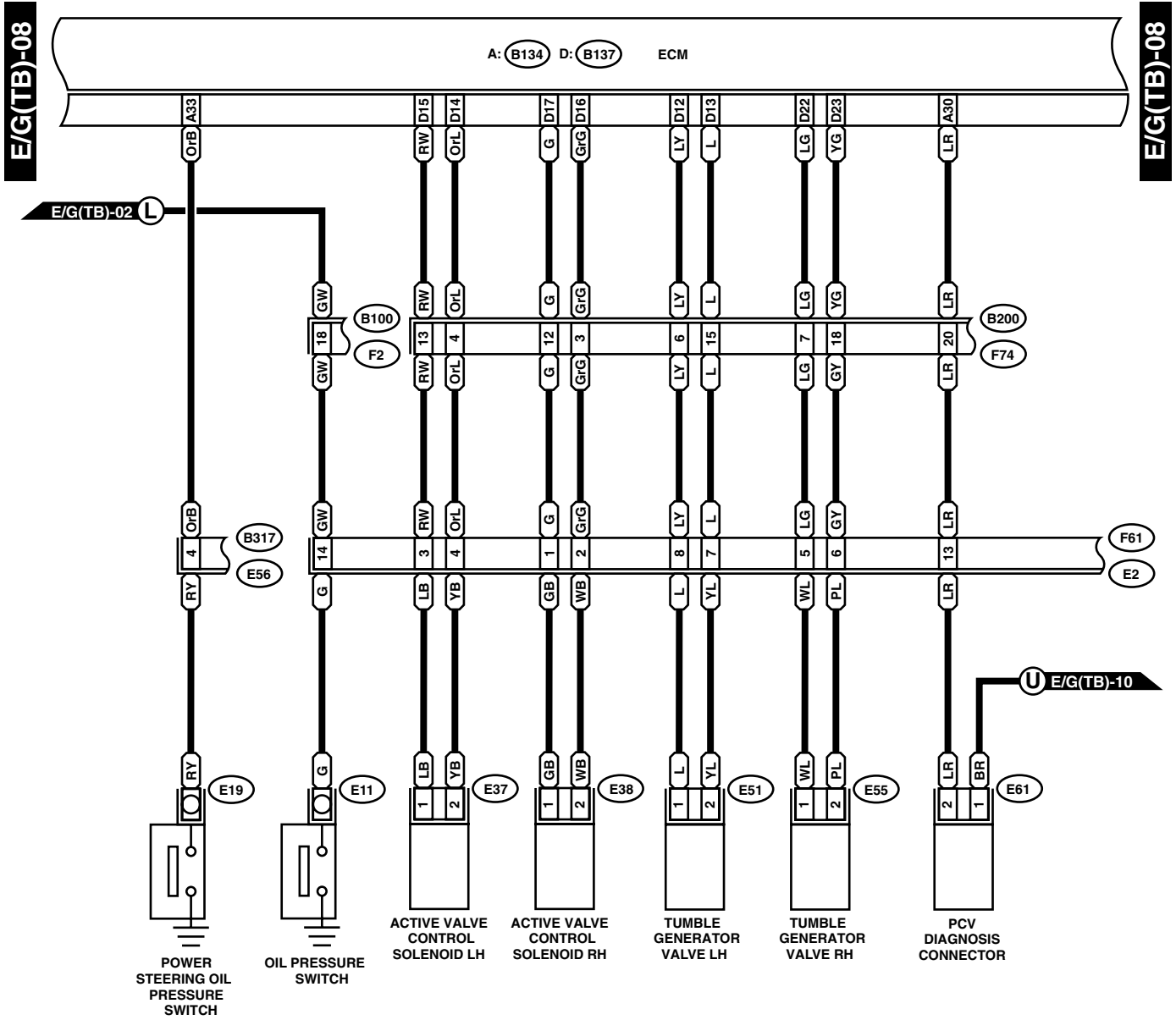

WI-08891

# Engine Electrical System

WIRING SYSTEM

E/G(NA)-07

E/G(NA)-07

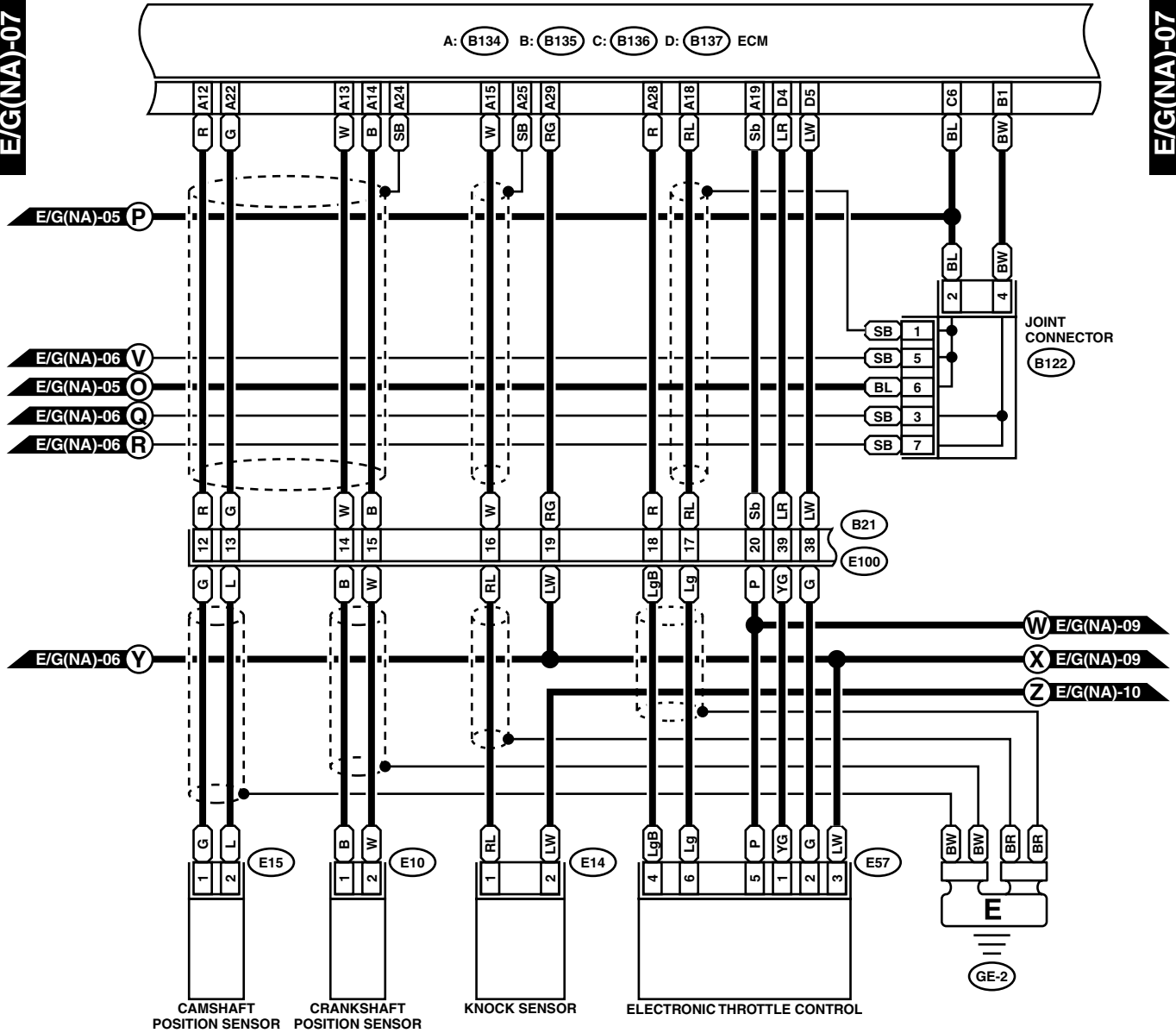

E10 (LIGHT GRAY)

E57 (BLACK)

B122

A: B134 HR

B21 (BLACK)

E15 (GRAY)

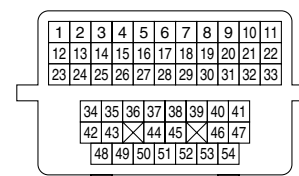
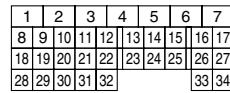
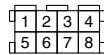
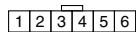

B: B135 HR

C: B136 HR

D: B137 HR

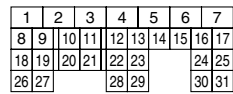
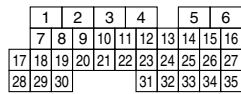
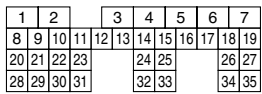

WI-08903

# Engine Electrical System

WIRING SYSTEM

E/G(NA)-09

E/G(NA)-09

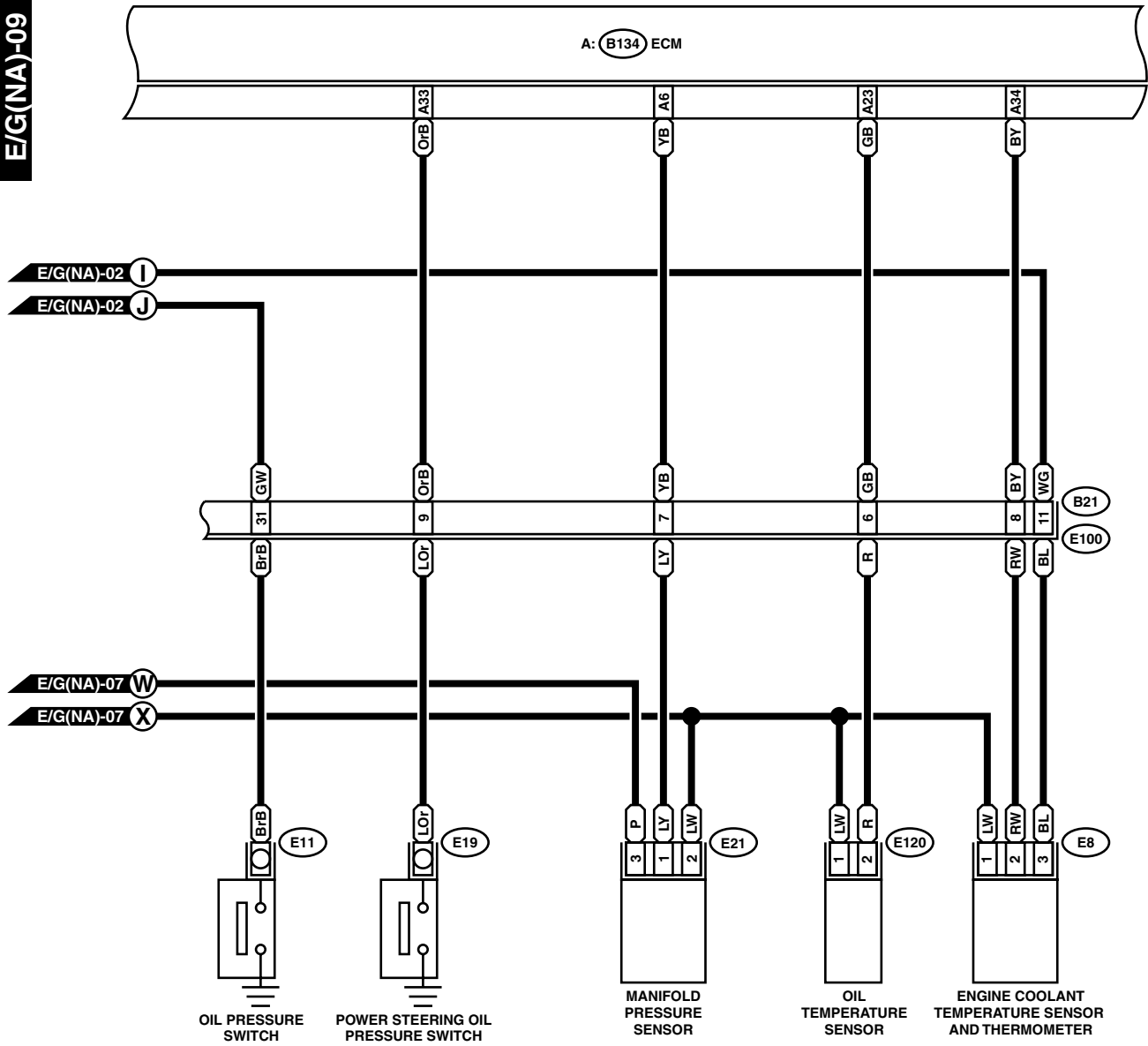

E120 (BLACK)



E8 (LIGHT GRAY)



E21 (BLACK)



A: B134 HR

1	2	3	4	5	6	7			
8	9	10	11	12	13	14	15	16	17
18	19	20	21	22	23	24	25	26	27
28	29	30	31	32				33	34

B21 (BLACK)

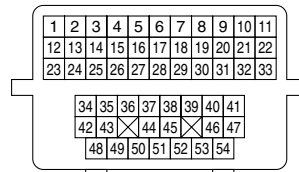

WI-08905

# Engine Electrical System

WIRING SYSTEM

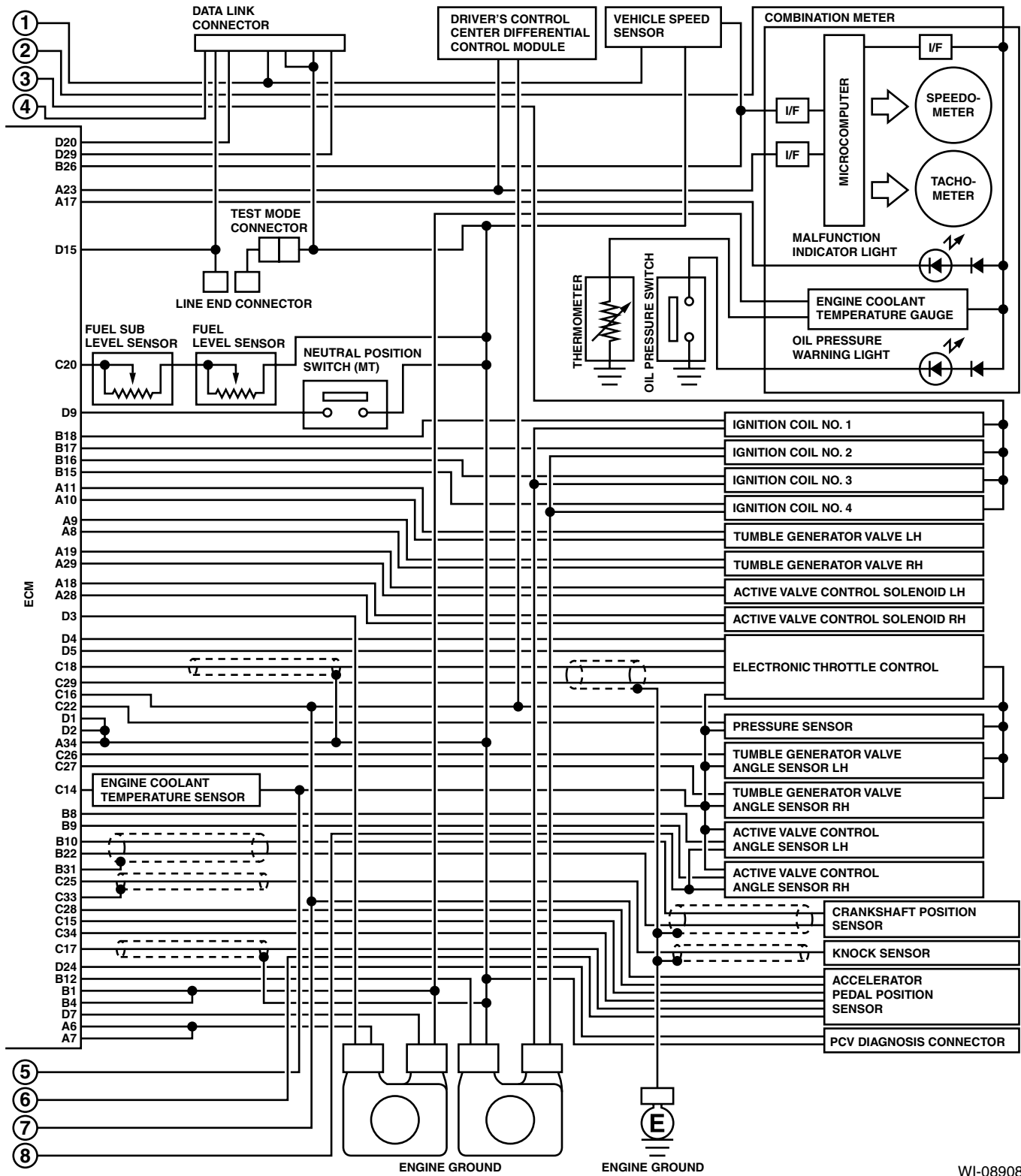

WI-08908

# Engine Electrical System

WIRING SYSTEM

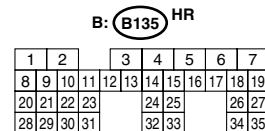
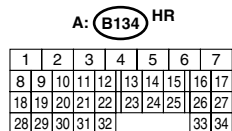
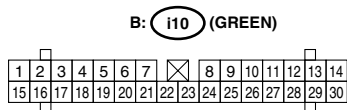
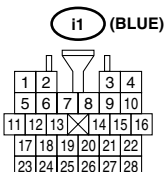
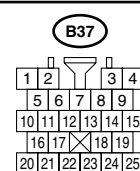
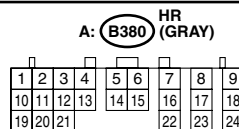
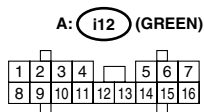
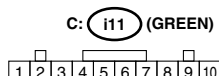
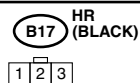
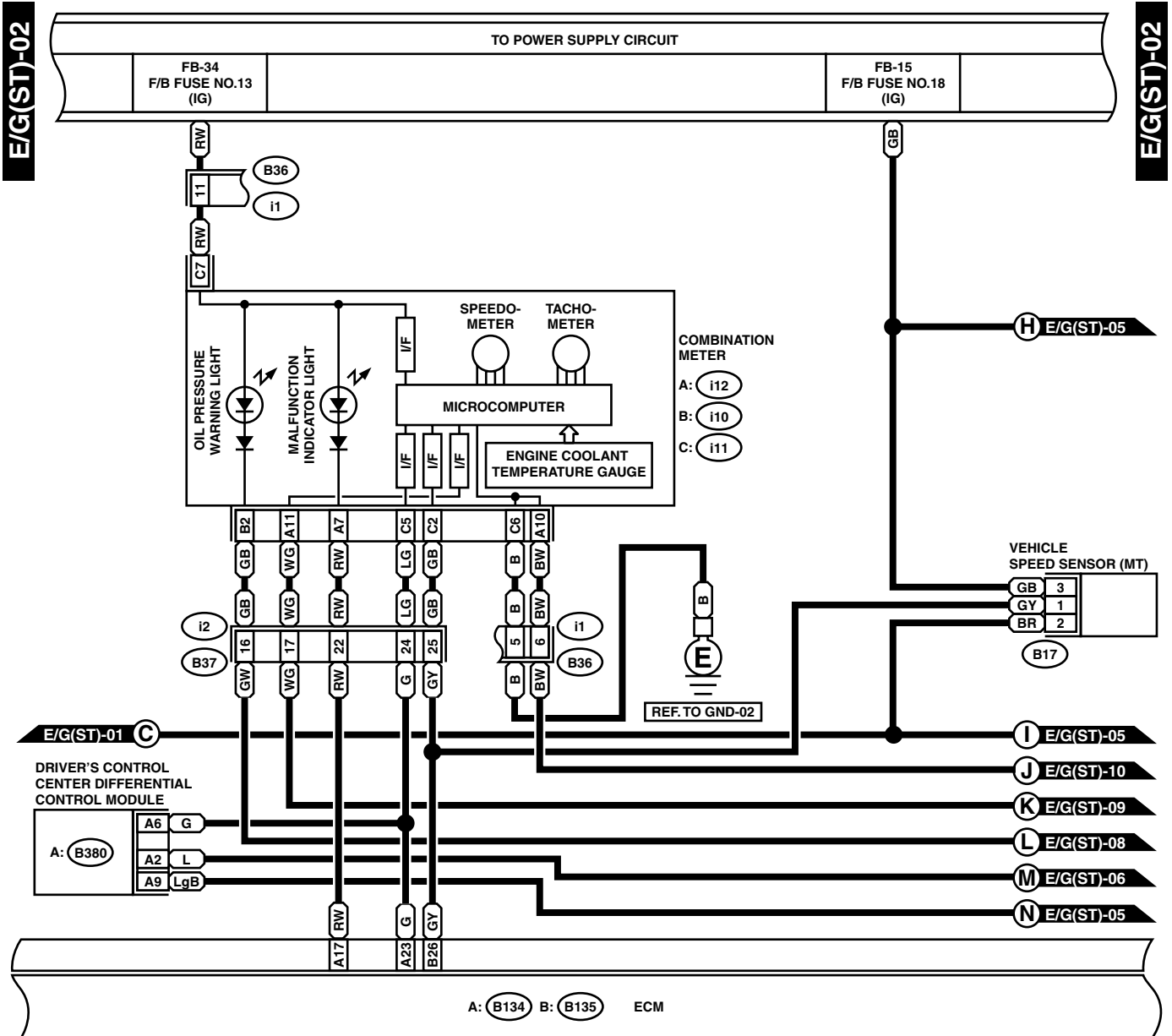

WI-08910



# Engine Electrical System

WIRING SYSTEM

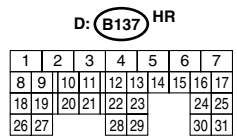
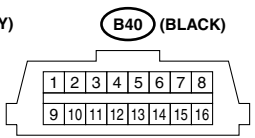
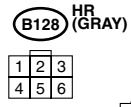
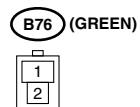
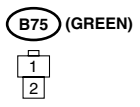
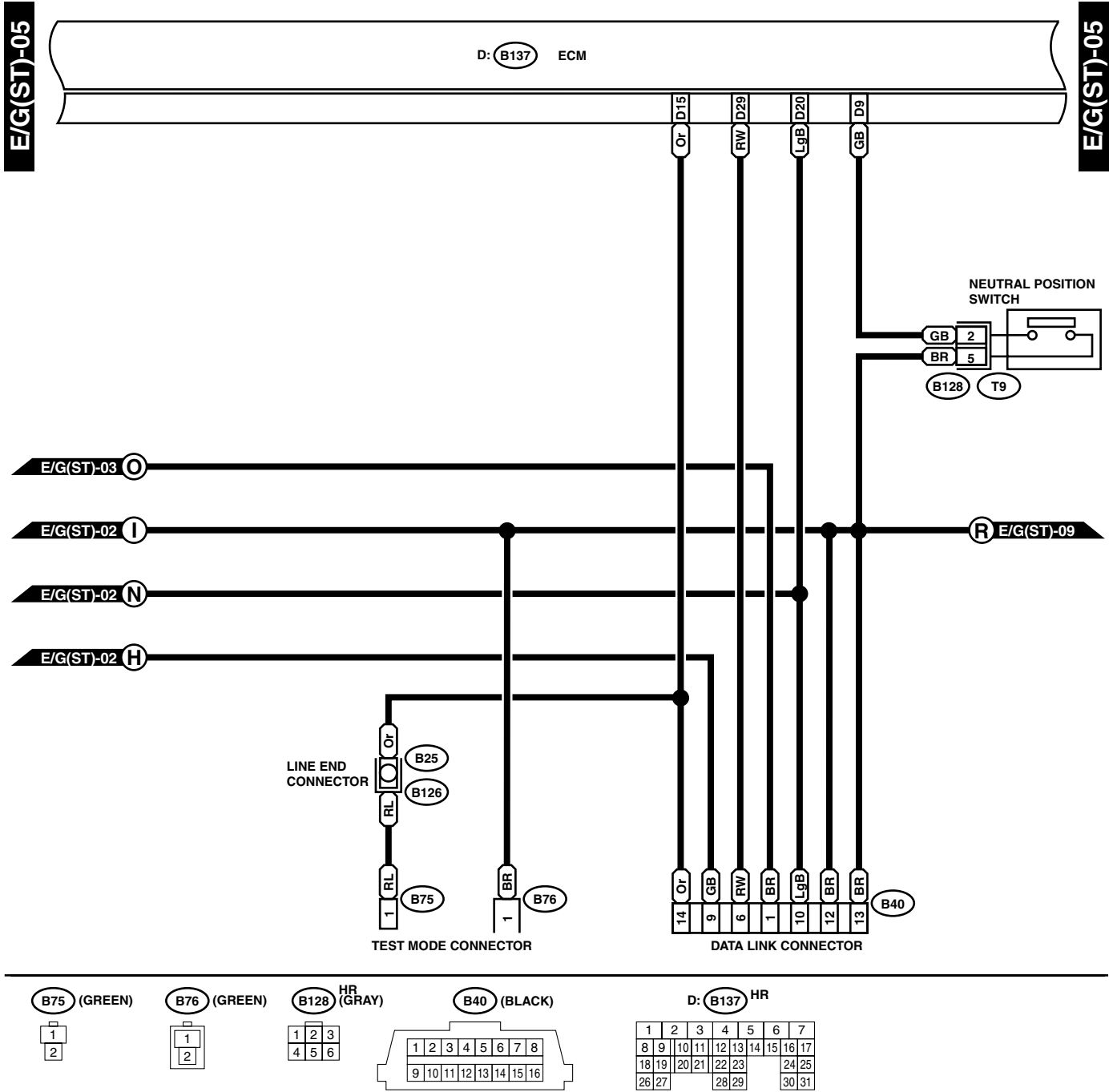

WI-08913

# Engine Electrical System

WIRING SYSTEM

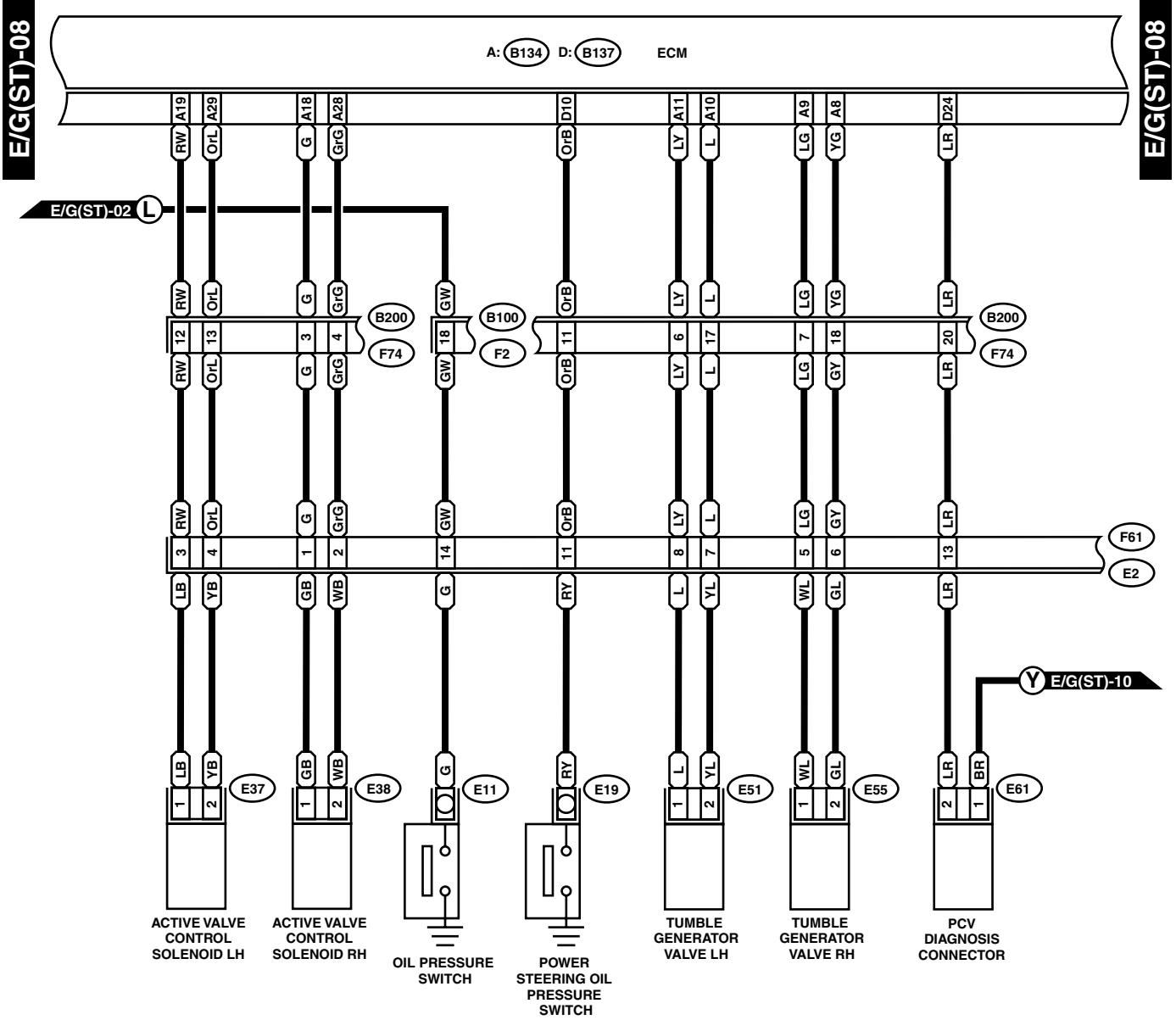

E37 (BLUE)

E38 (BLUE)

E51 (BLACK)

E55 (BLACK)

E61 (DARK GRAY)

1 2

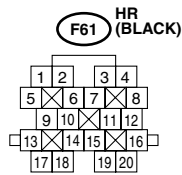

F74 (BLUE)

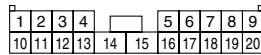

F2 (BLACK)

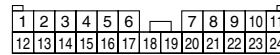

A: (B134) HR

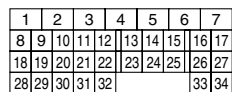

D: (B137) HR



WI-08916

# Engine Electrical System

WIRING SYSTEM

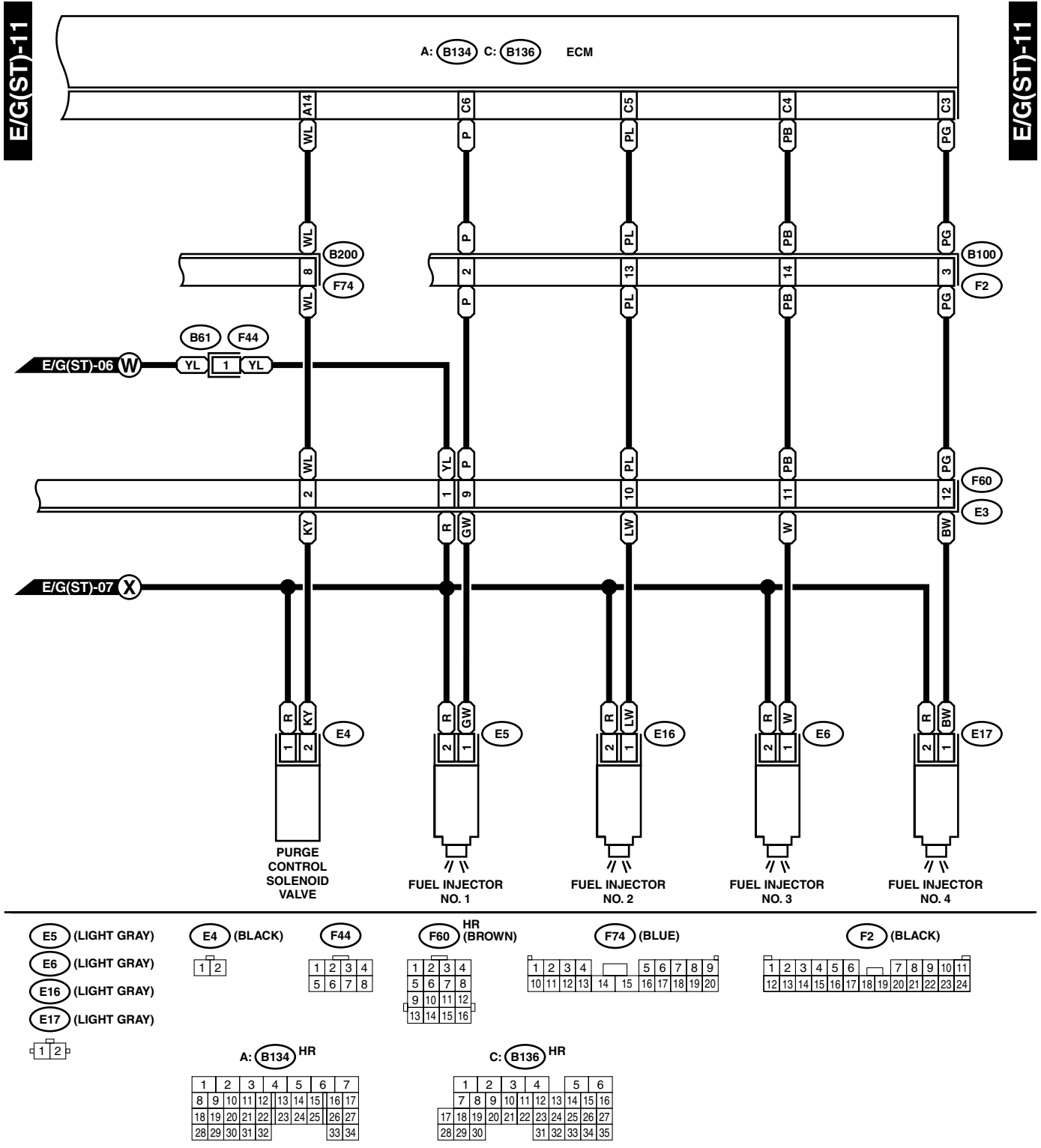

WI-08919

# AT Control System

WIRING SYSTEM

AT(TB)-01

AT(TB)-01

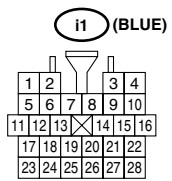
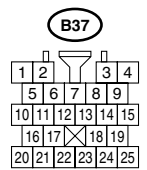
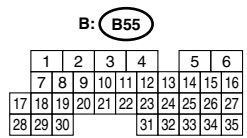
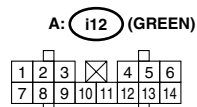
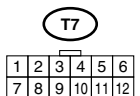
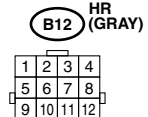
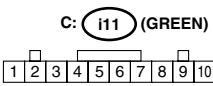
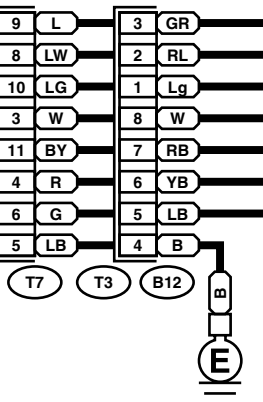
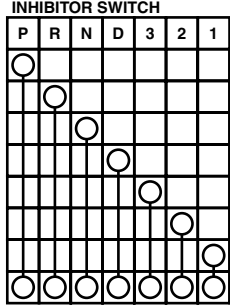
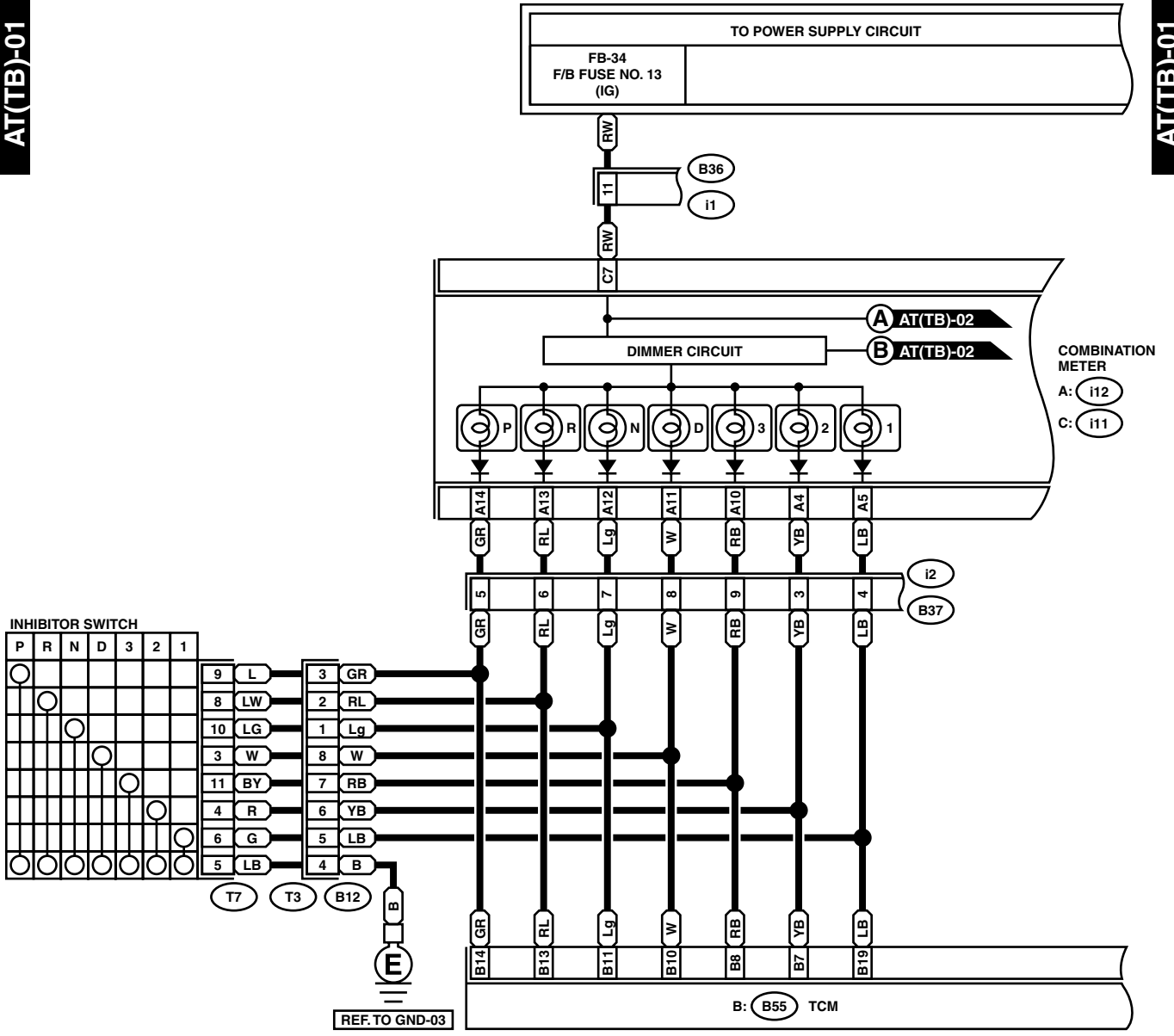

WI-08921

# AT Control System

## WIRING SYSTEM

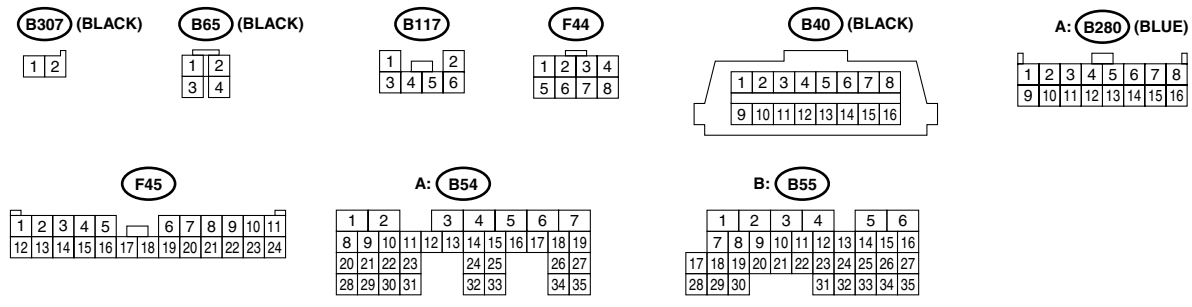
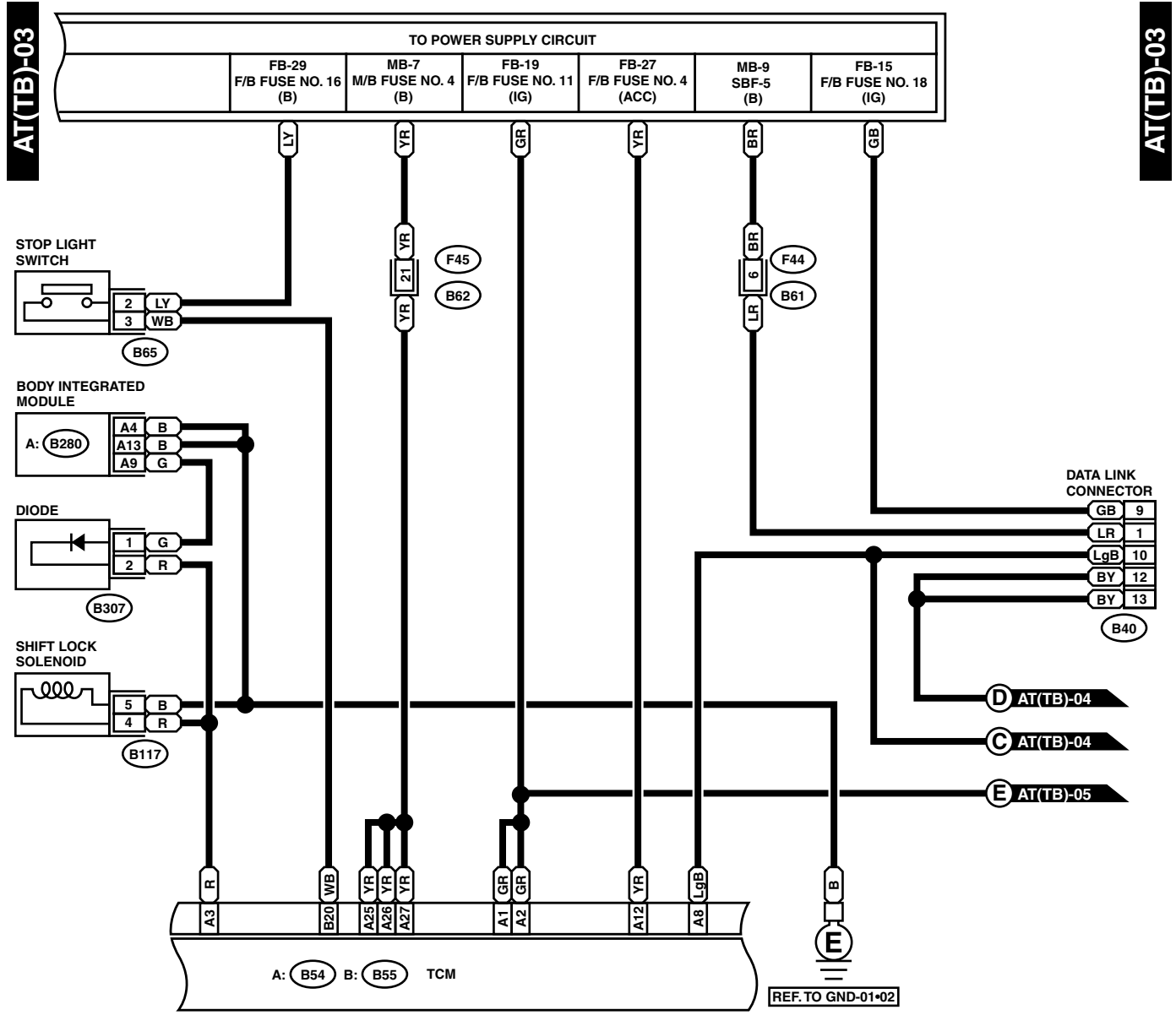

WI-08923

# AT Control System

WIRING SYSTEM

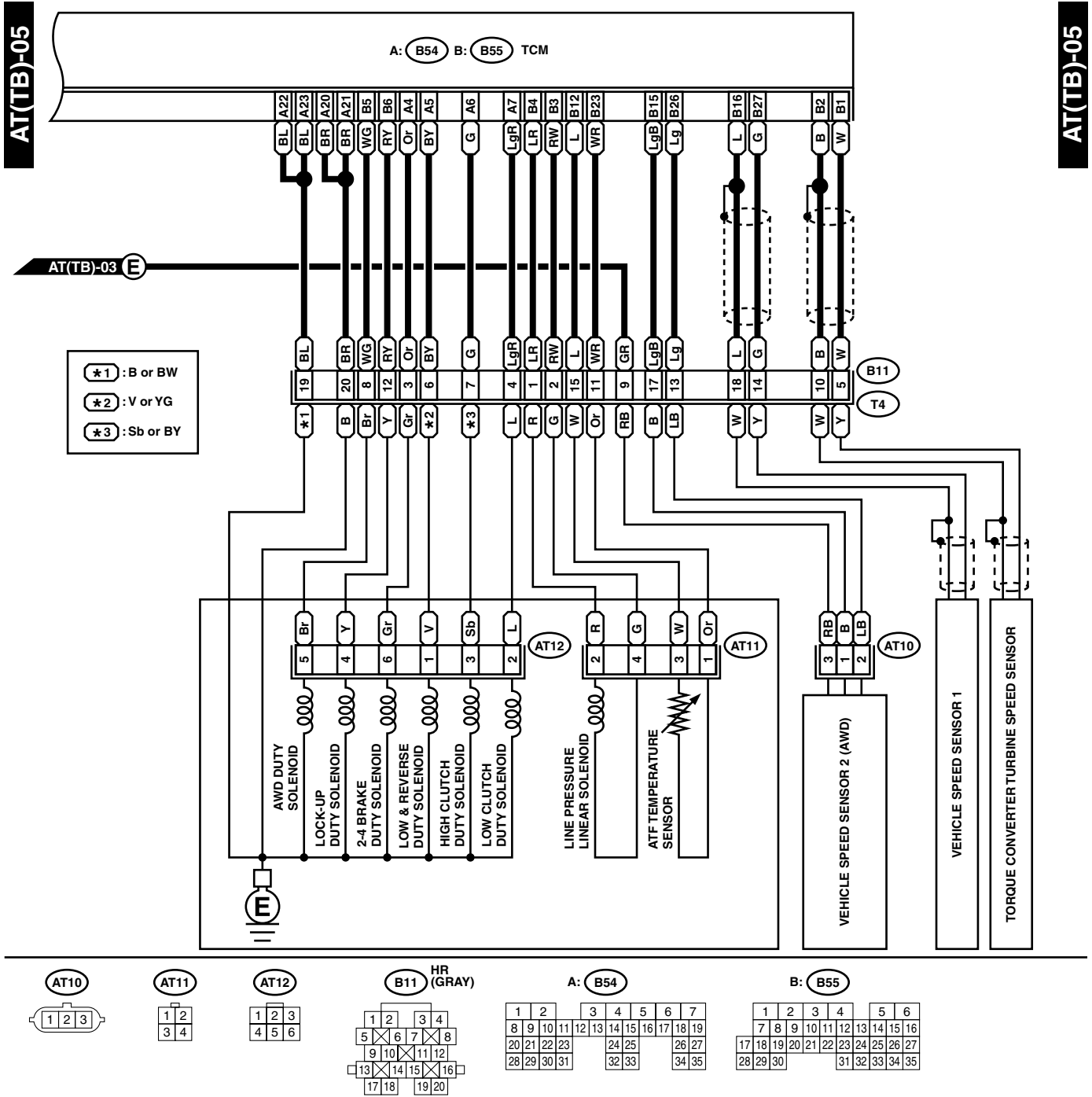

WI-10736

# AT Control System

WIRING SYSTEM

AT(NA)-02

AT(NA)-02

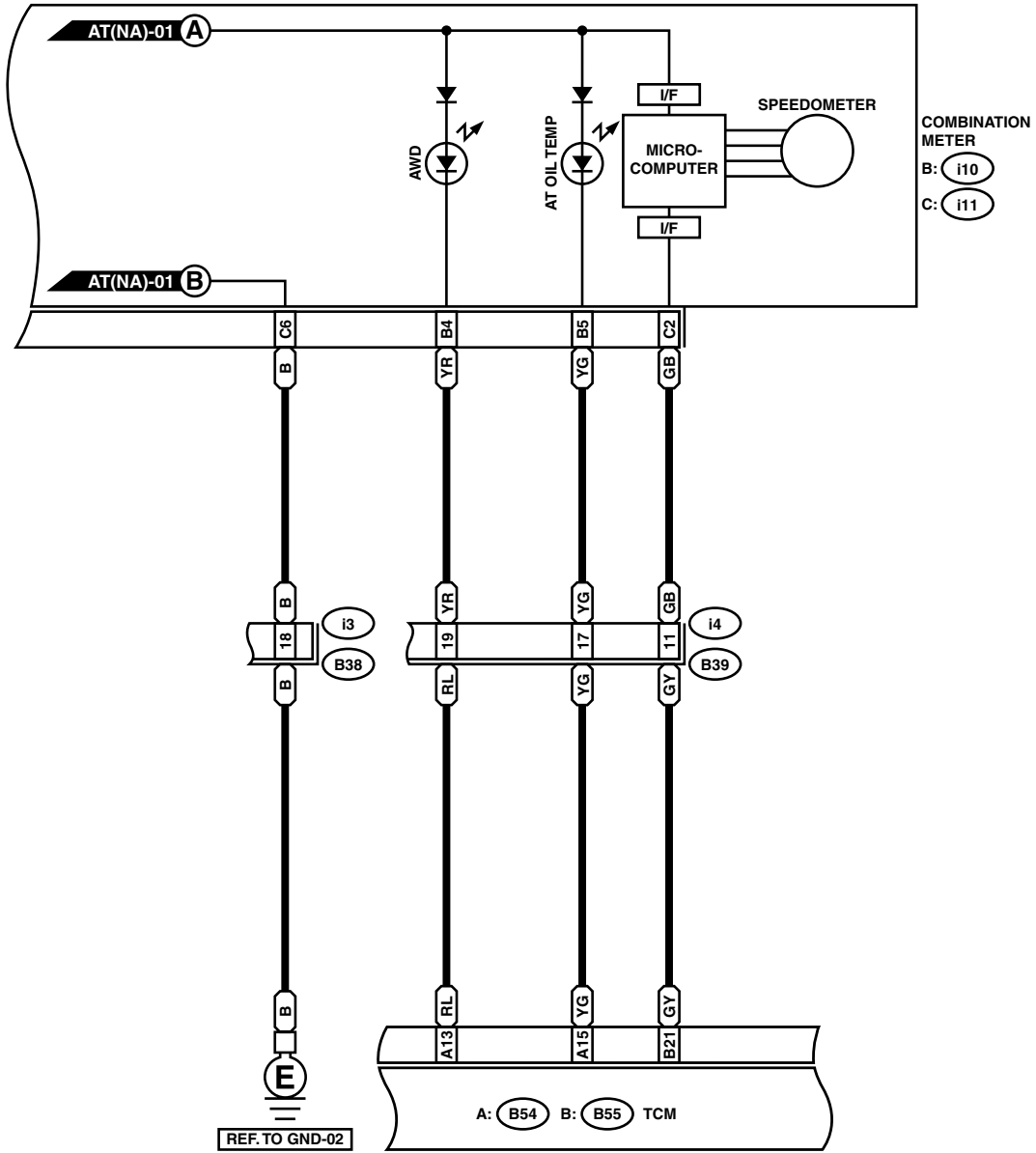

C: i11 (GREEN)

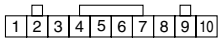

i3

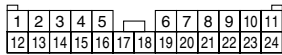

i4 (BROWN)

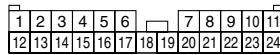

B: i10 (GREEN)

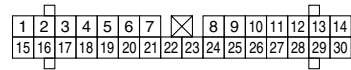

A: B54

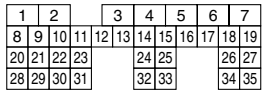

B: B55

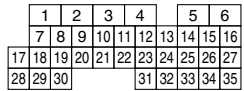

WI-08928