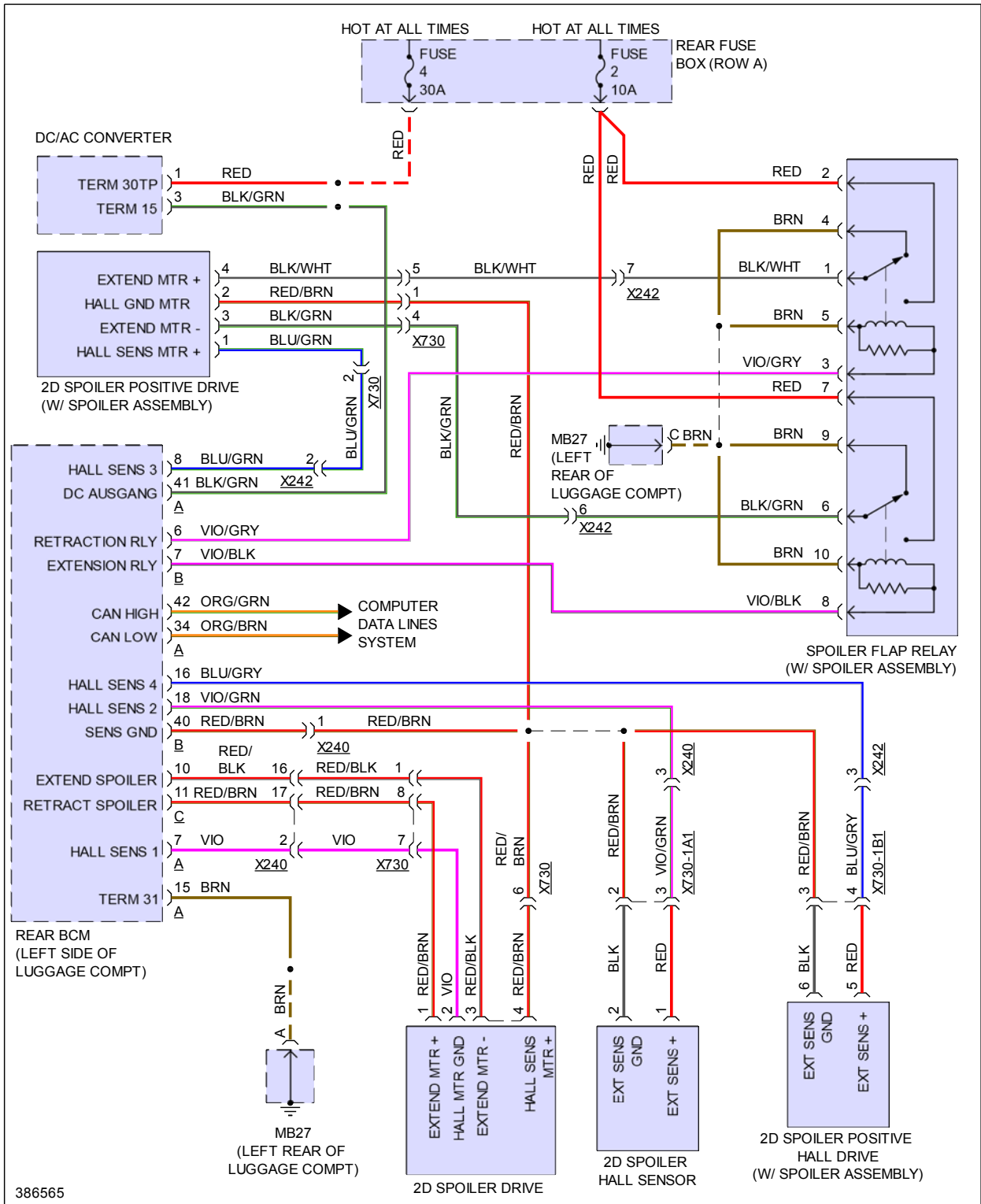

Fig 1: Active Bodyworks Circuit



386565

Fig 2: Automatic A/C Circuit, Except Hybrid (2 of 4)

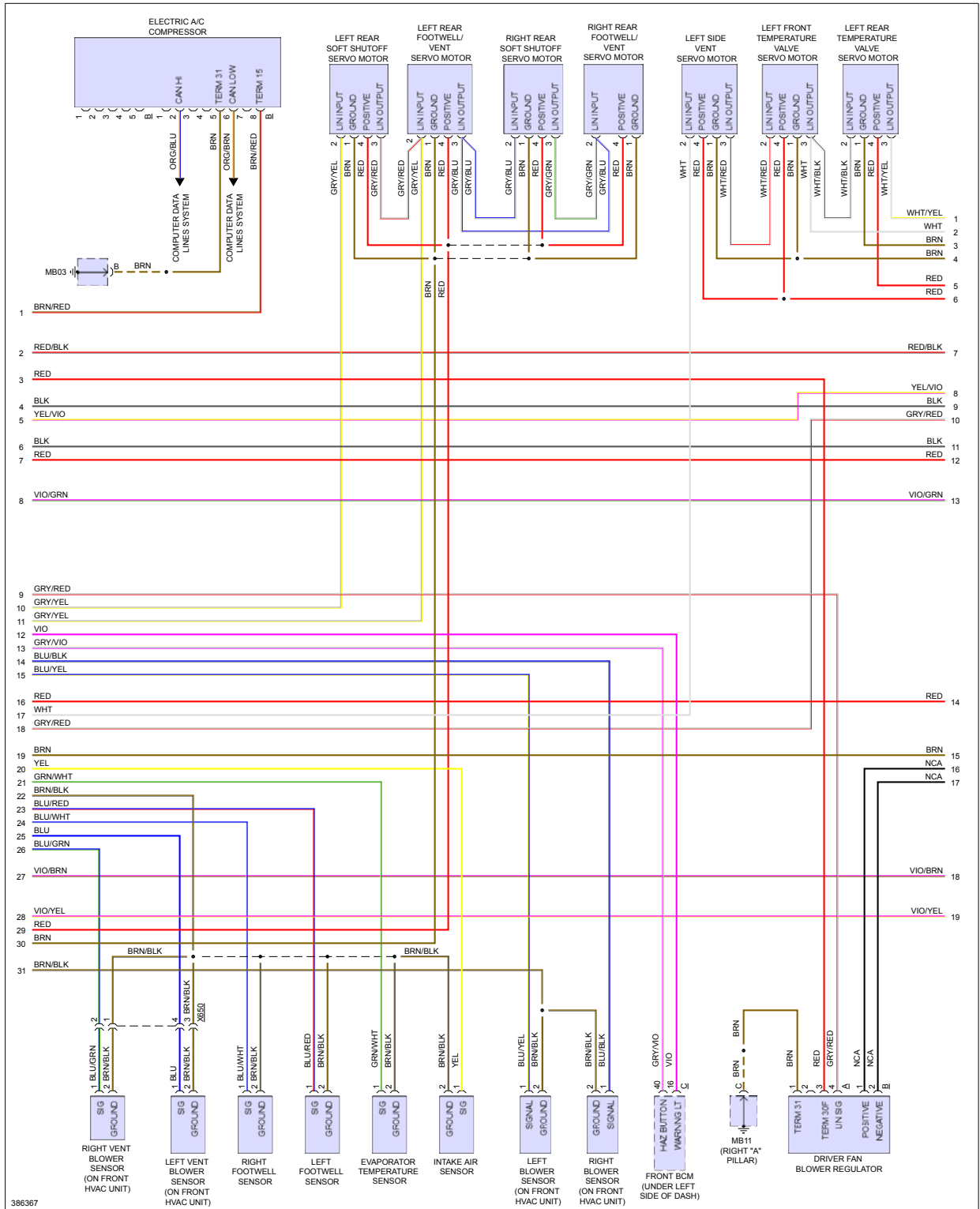
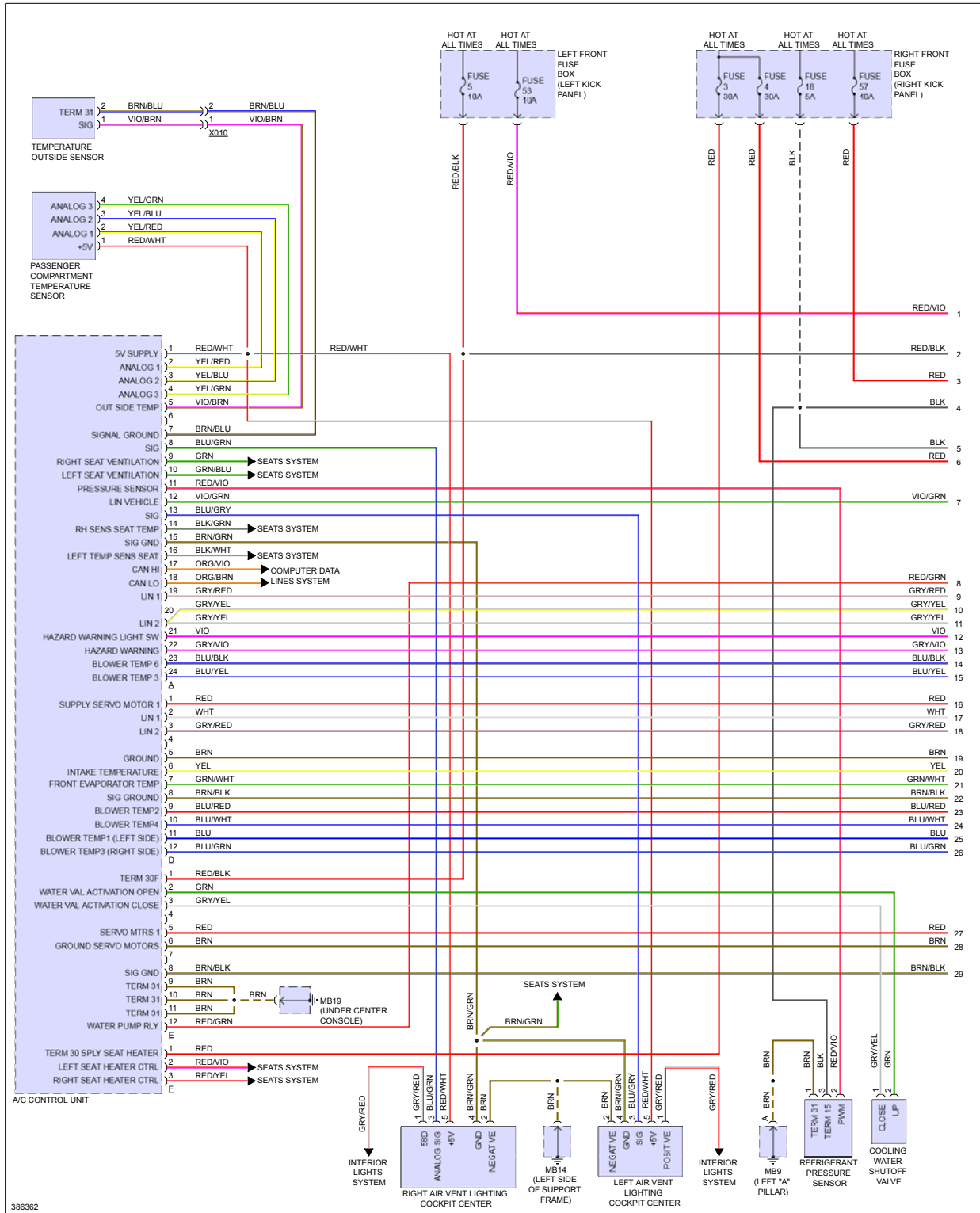
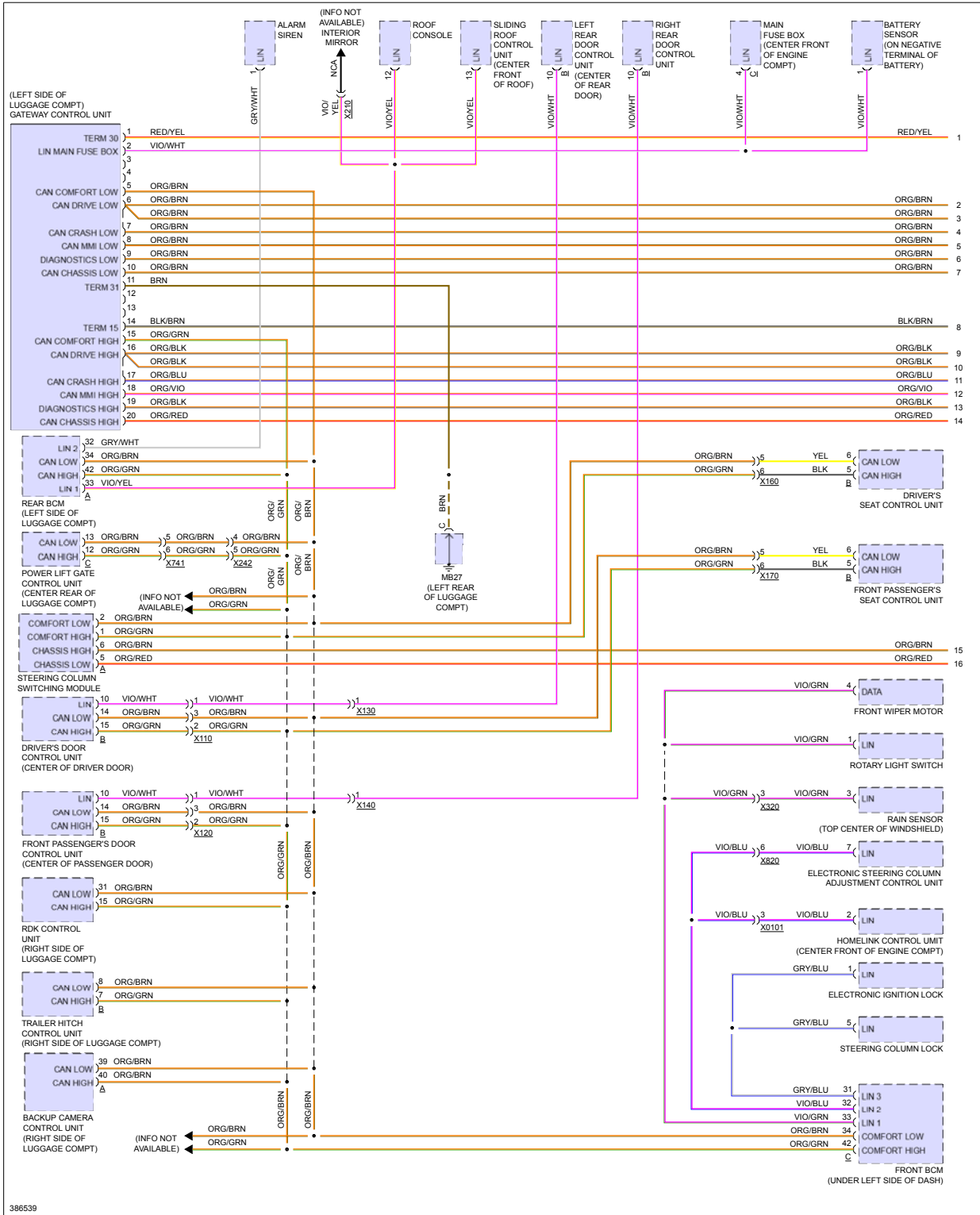

Fig 5: Automatic A/C Circuit, Hybrid (1 of 4)



COMPUTER DATA LINES

Fig 1: Computer Data Lines Circuit (1 of 3)



ELECTRONIC POWER STEERING

Fig 1: Electronic Power Steering Circuit

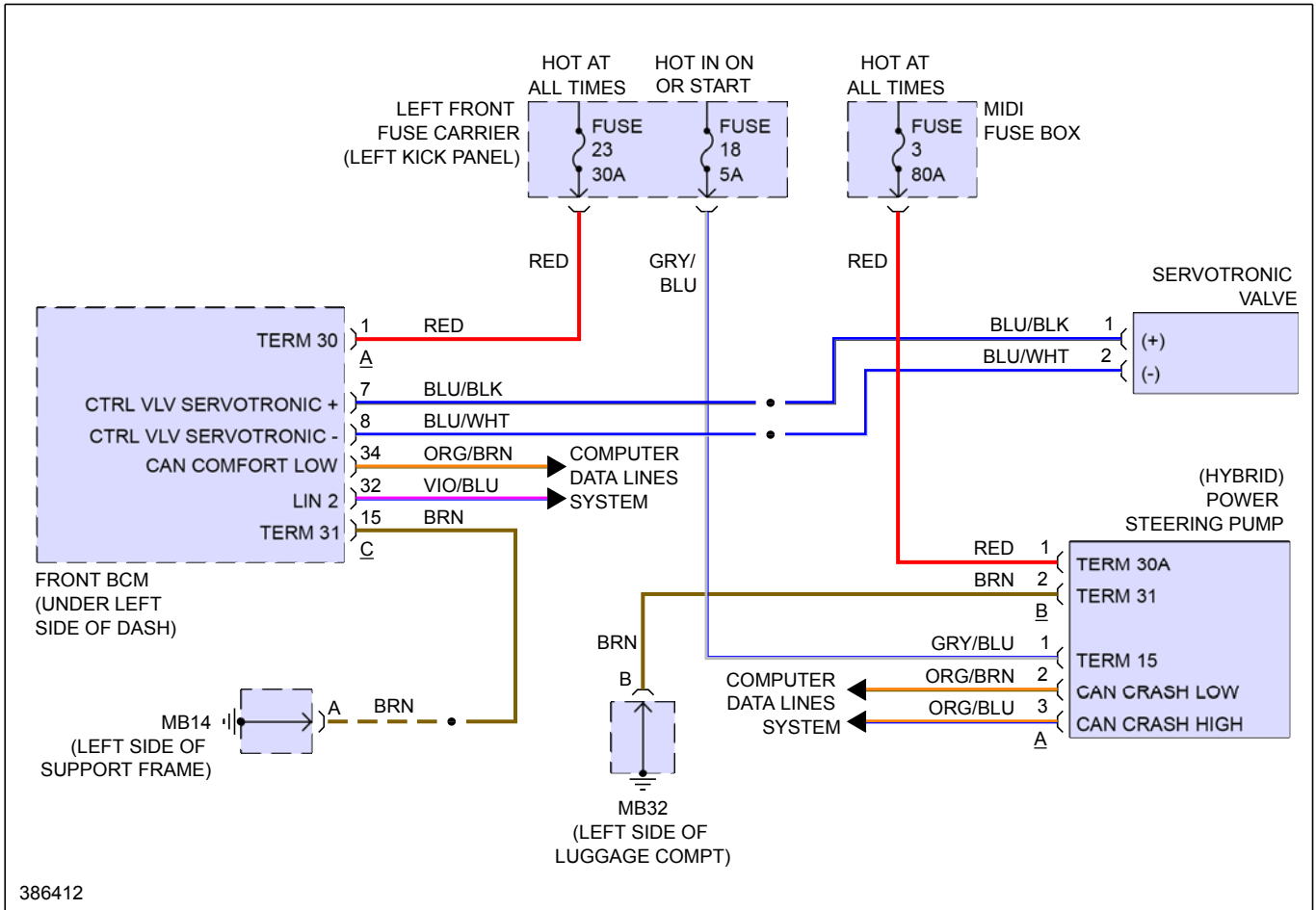
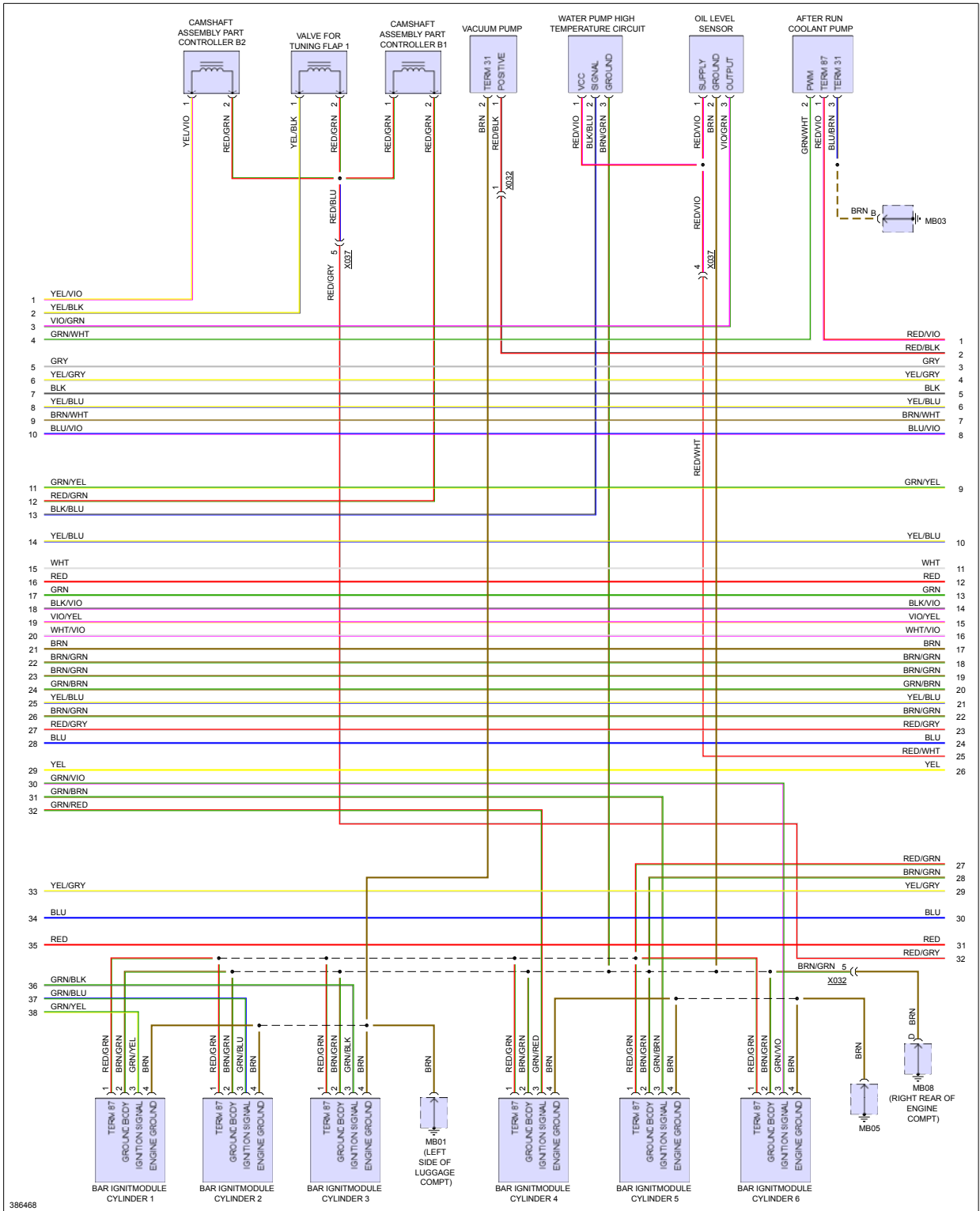

Fig 2: 3.0L Hybrid, Engine Performance Circuit (2 of 7)



386468

Fig 2: 3.6L, Engine Performance Circuit (2 of 5)

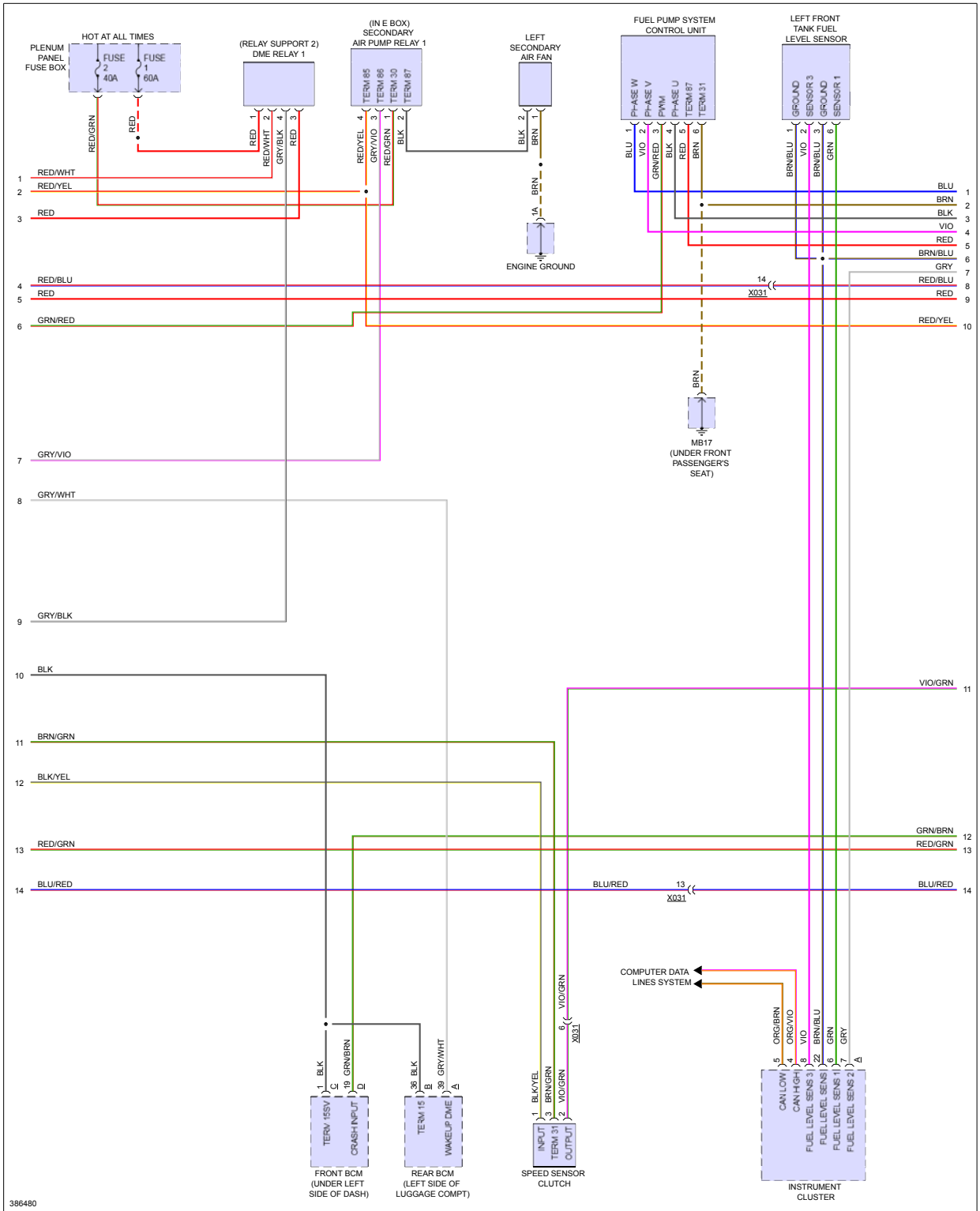

Fig 2: 4.8L Twin Turbo, Engine Performance Circuit (2 of 5)

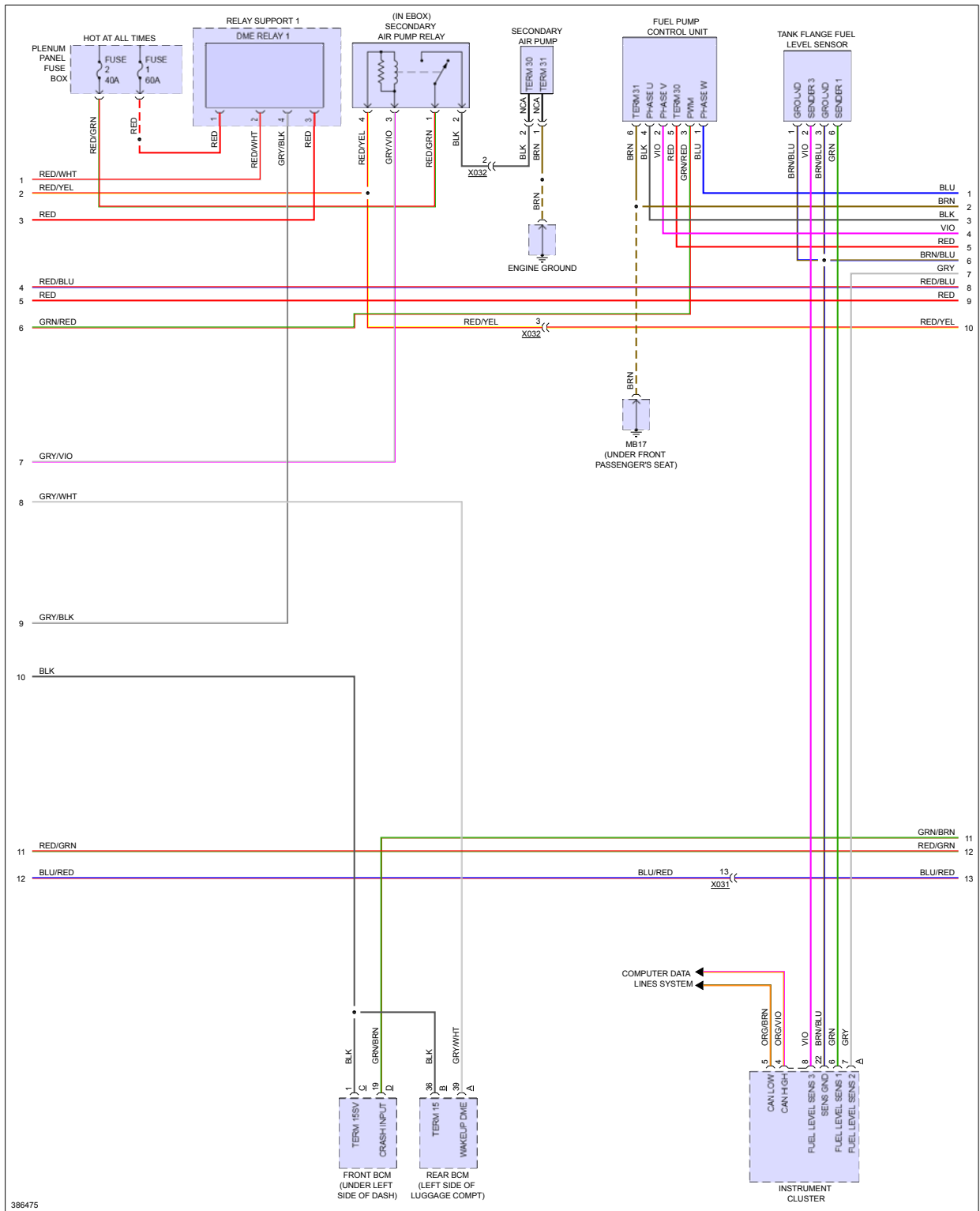

Fig 2: Exterior Lamps Circuit (1 of 2)

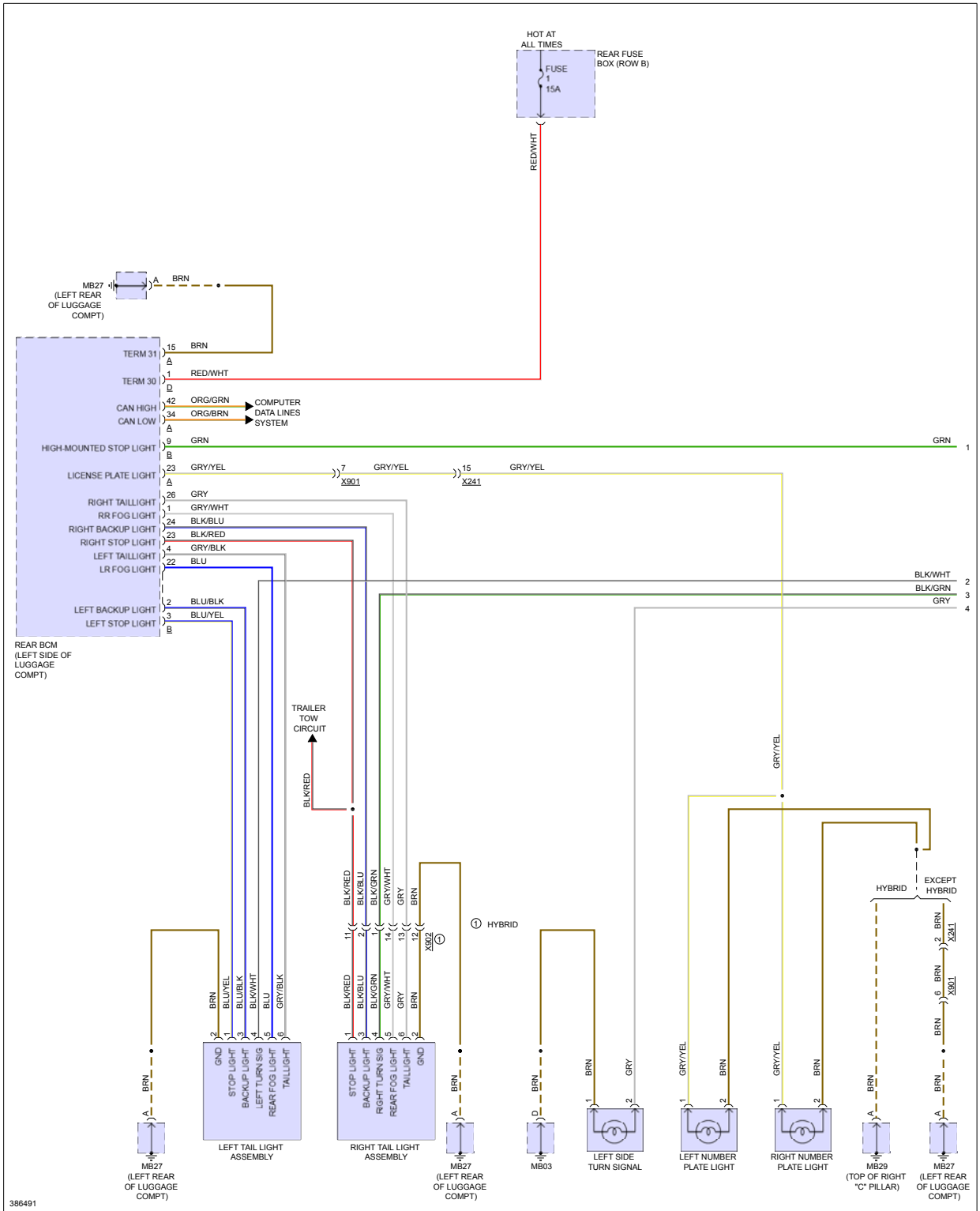

Fig 6: Ground Distribution Circuit (6 of 6)

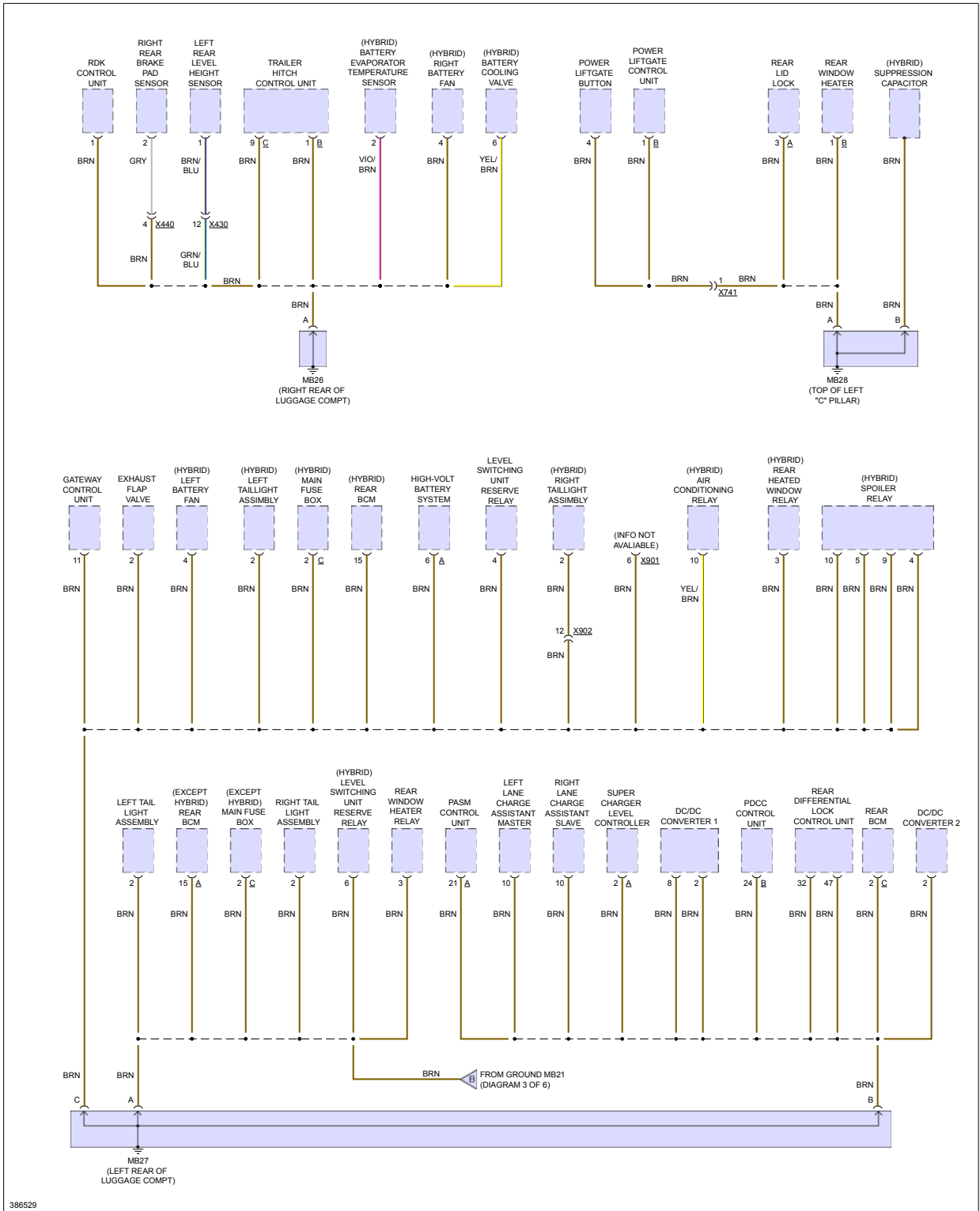

Fig 3: Interior Lights Circuit (3 of 5)

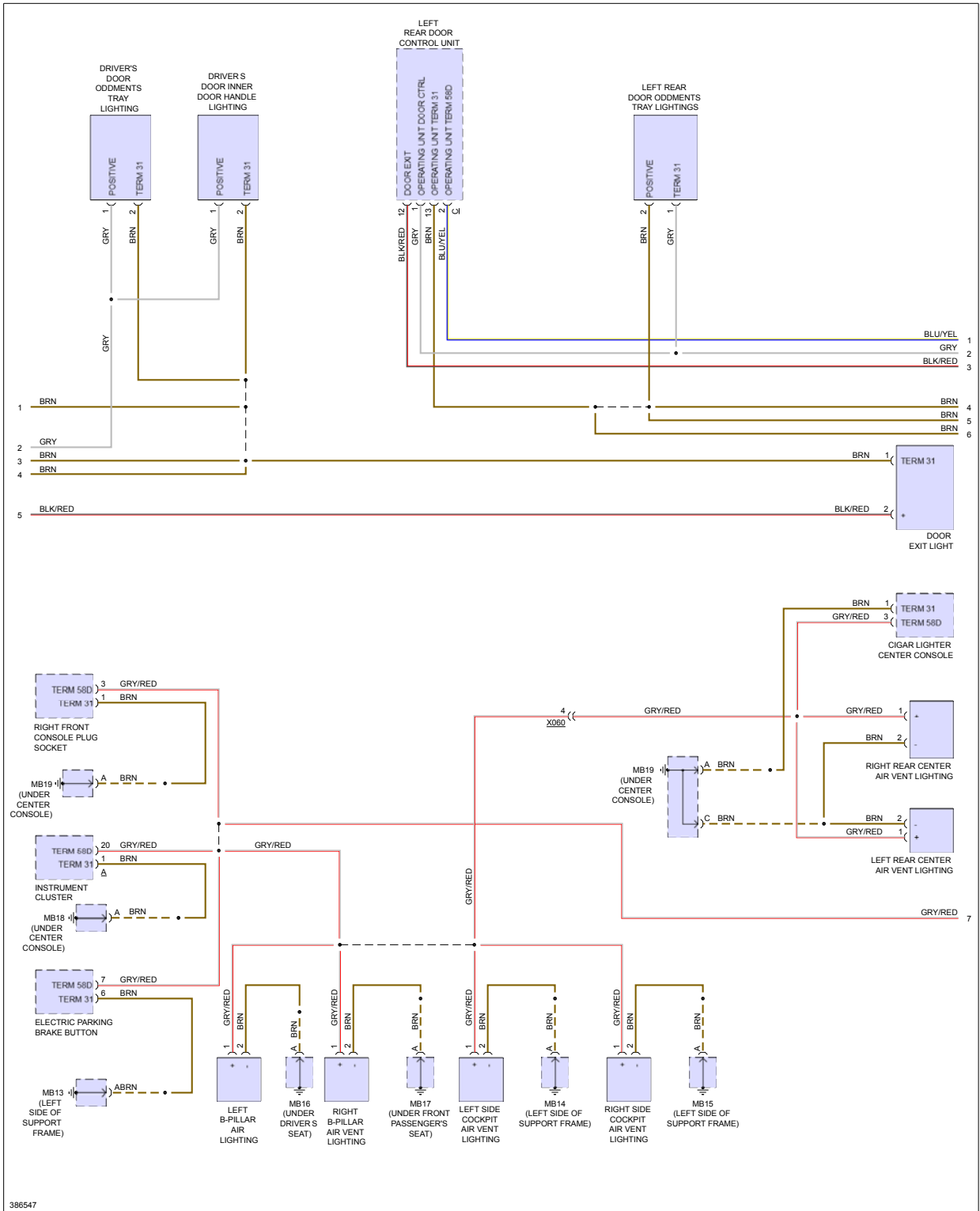
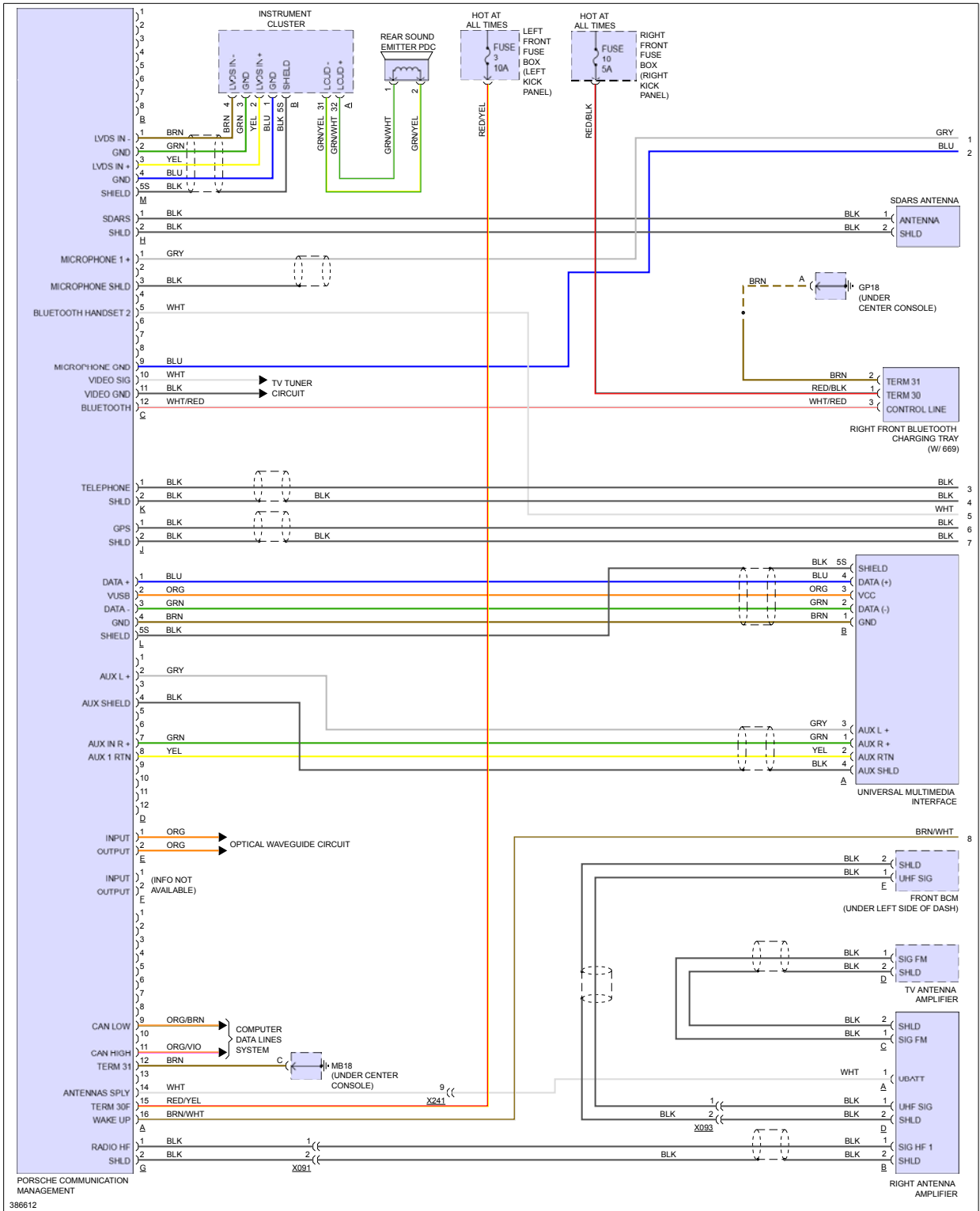

Fig 4: Navigation Circuit, W/ Bose (1 of 2)



POWER SEATS

Fig 1: Front Heated Seats Circuit, W/ Passenger Power Seats

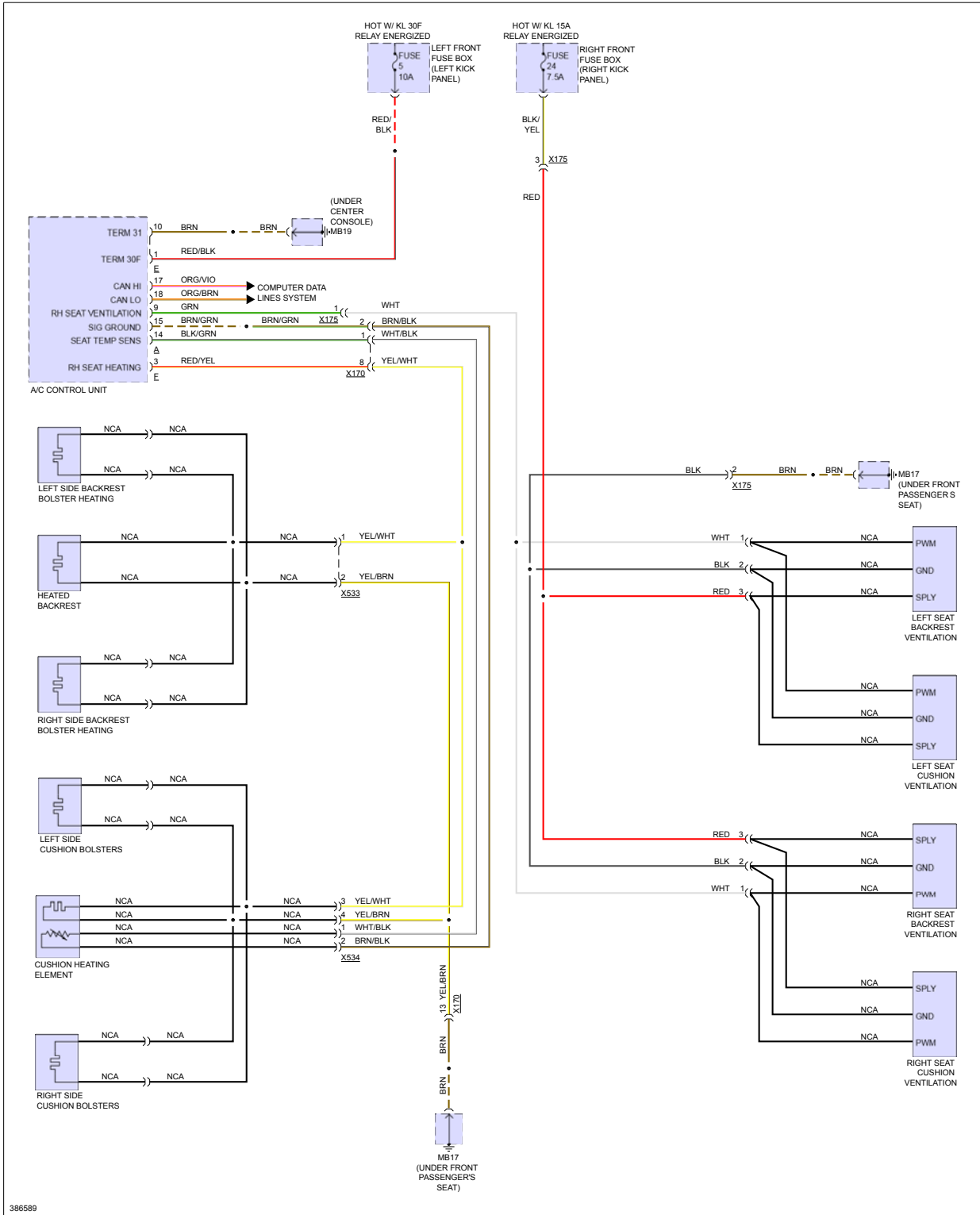

Fig 2: Rear Window Sun Shade Circuit

