

2008 Nissan Frontier SE

2008 SYSTEM WIRING DIAGRAMS Nissan - Frontier

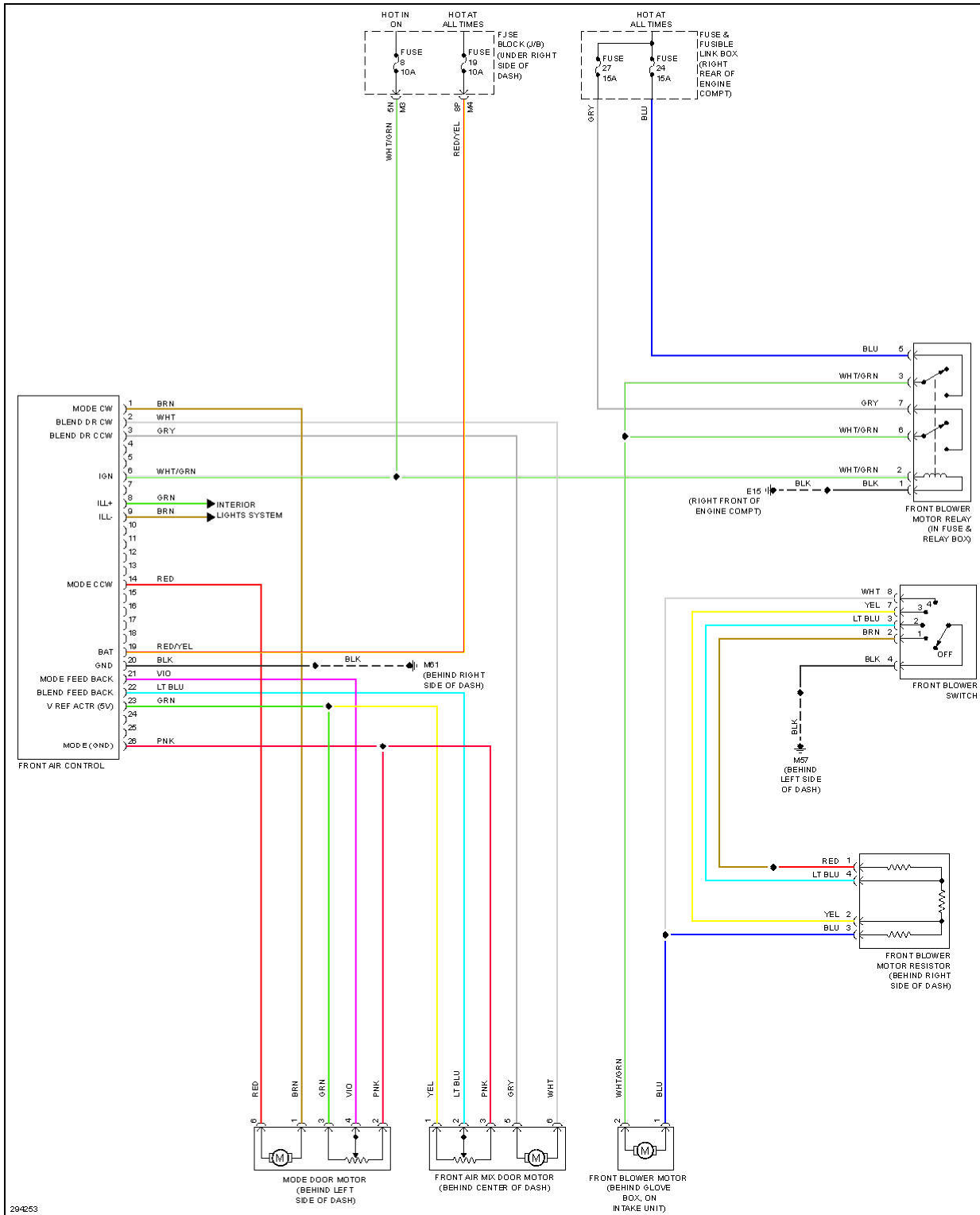

Fig. 1: Heater Circuit

2008 Nissan Frontier SE

2008 SYSTEM WIRING DIAGRAMS Nissan - Frontier

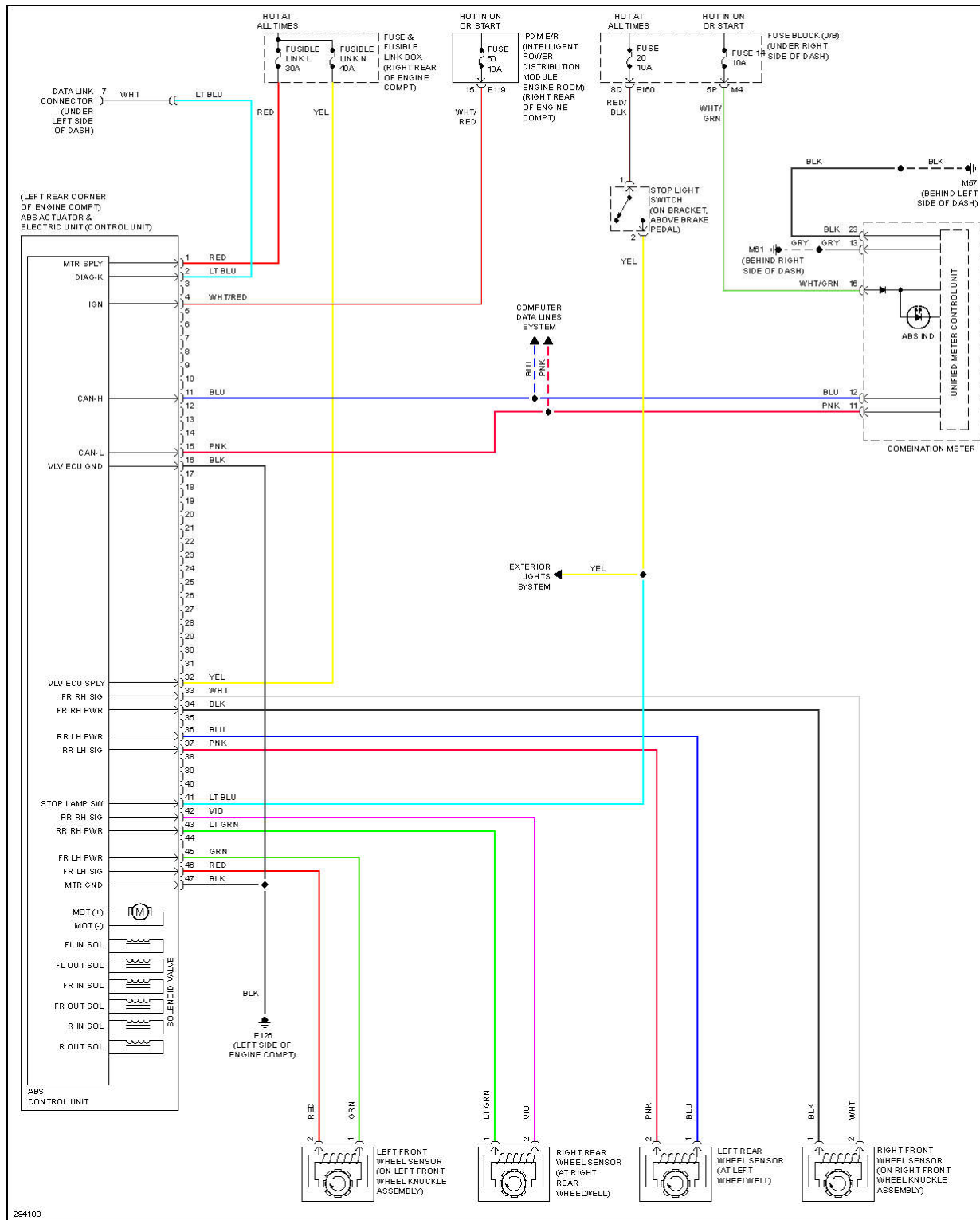

Fig. 6: Anti-lock Brakes Circuit, W/O Traction Control

BODY CONTROL MODULES

2008 Nissan Frontier SE

2008 SYSTEM WIRING DIAGRAMS Nissan - Frontier

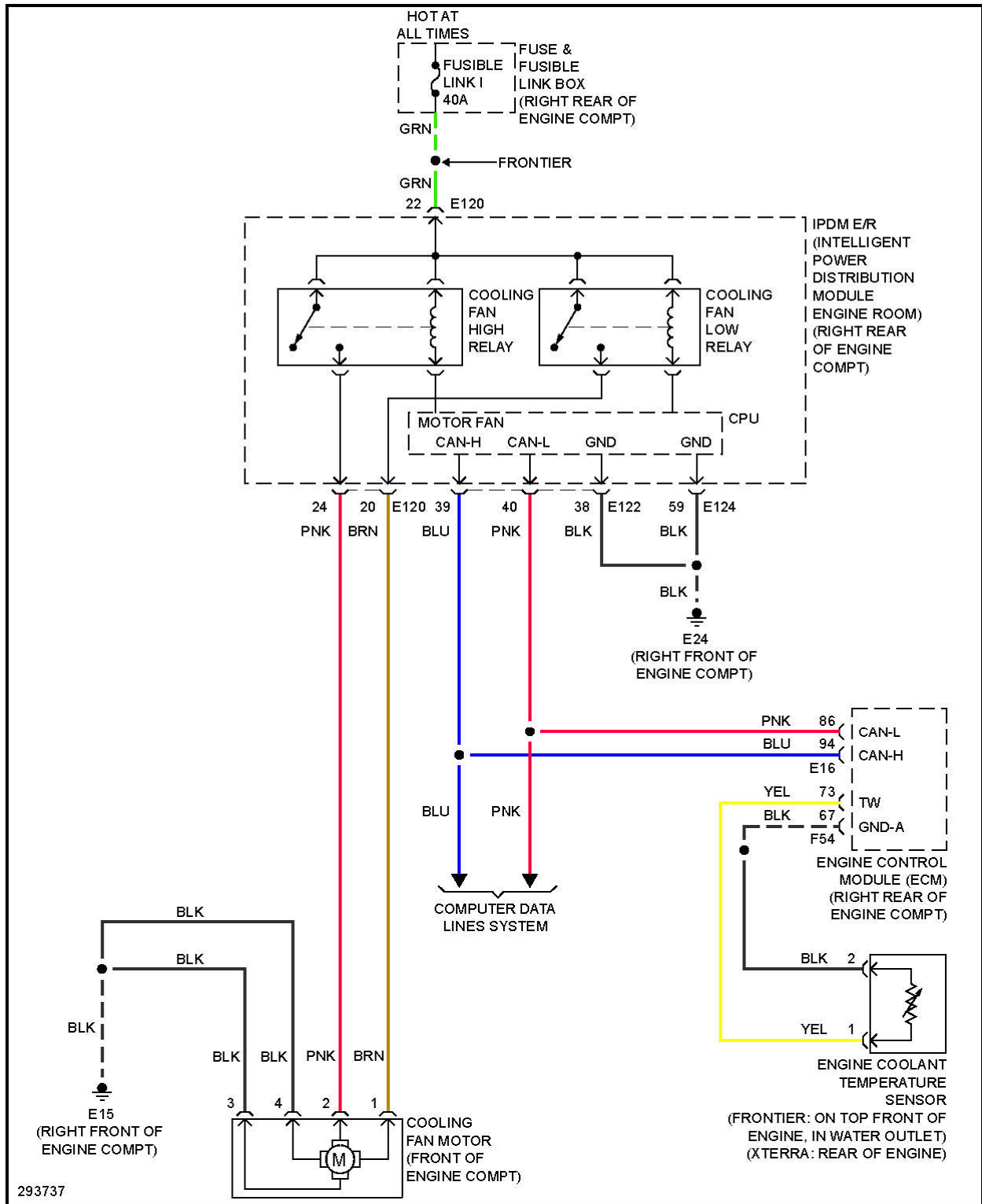

Fig. 12: 4.0L, Cooling Fan Circuit

2008 Nissan Frontier SE

2008 SYSTEM WIRING DIAGRAMS Nissan - Frontier

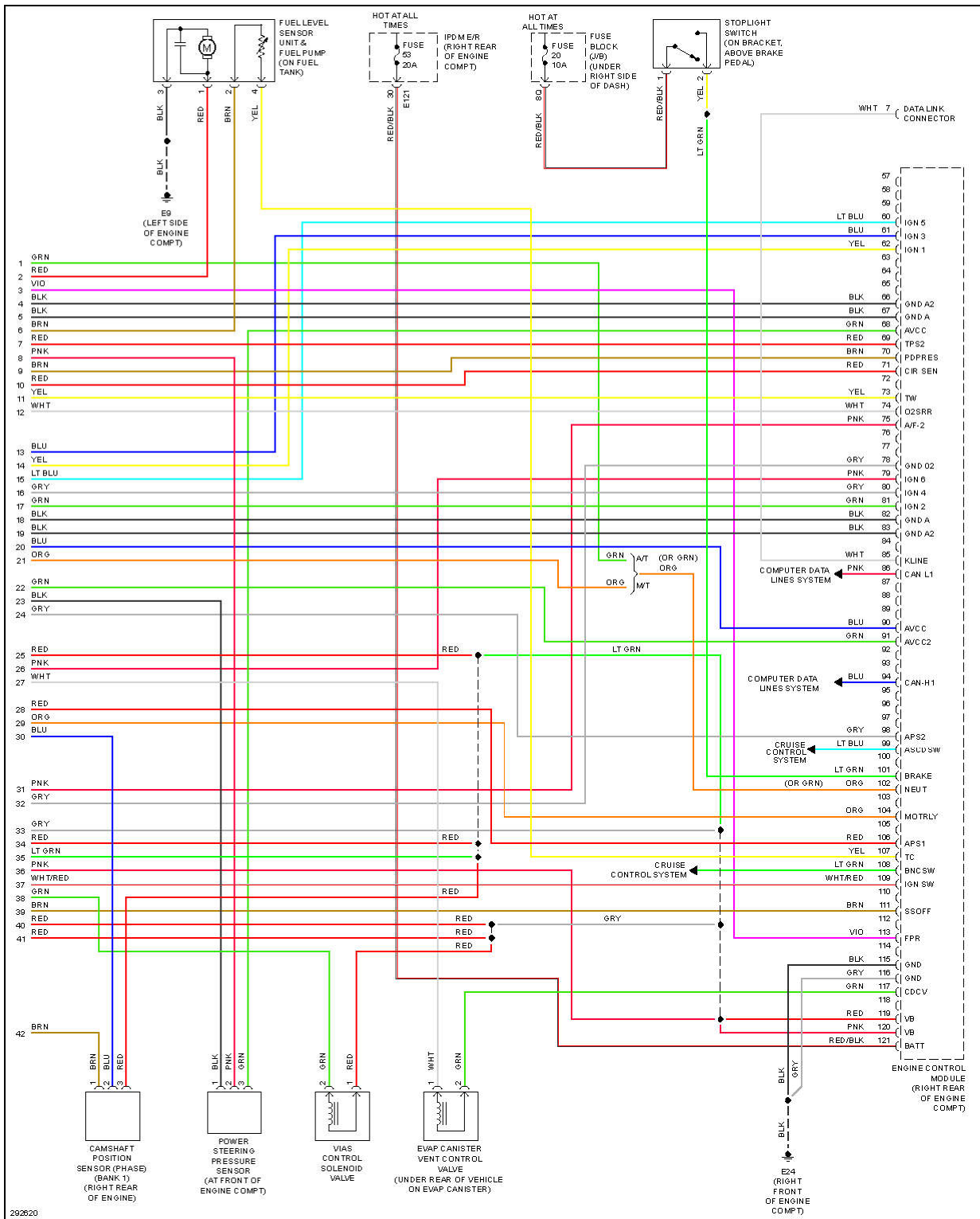

Fig. 22: 4.0L, Engine Performance Circuit (4 of 4)

HEADLIGHTS

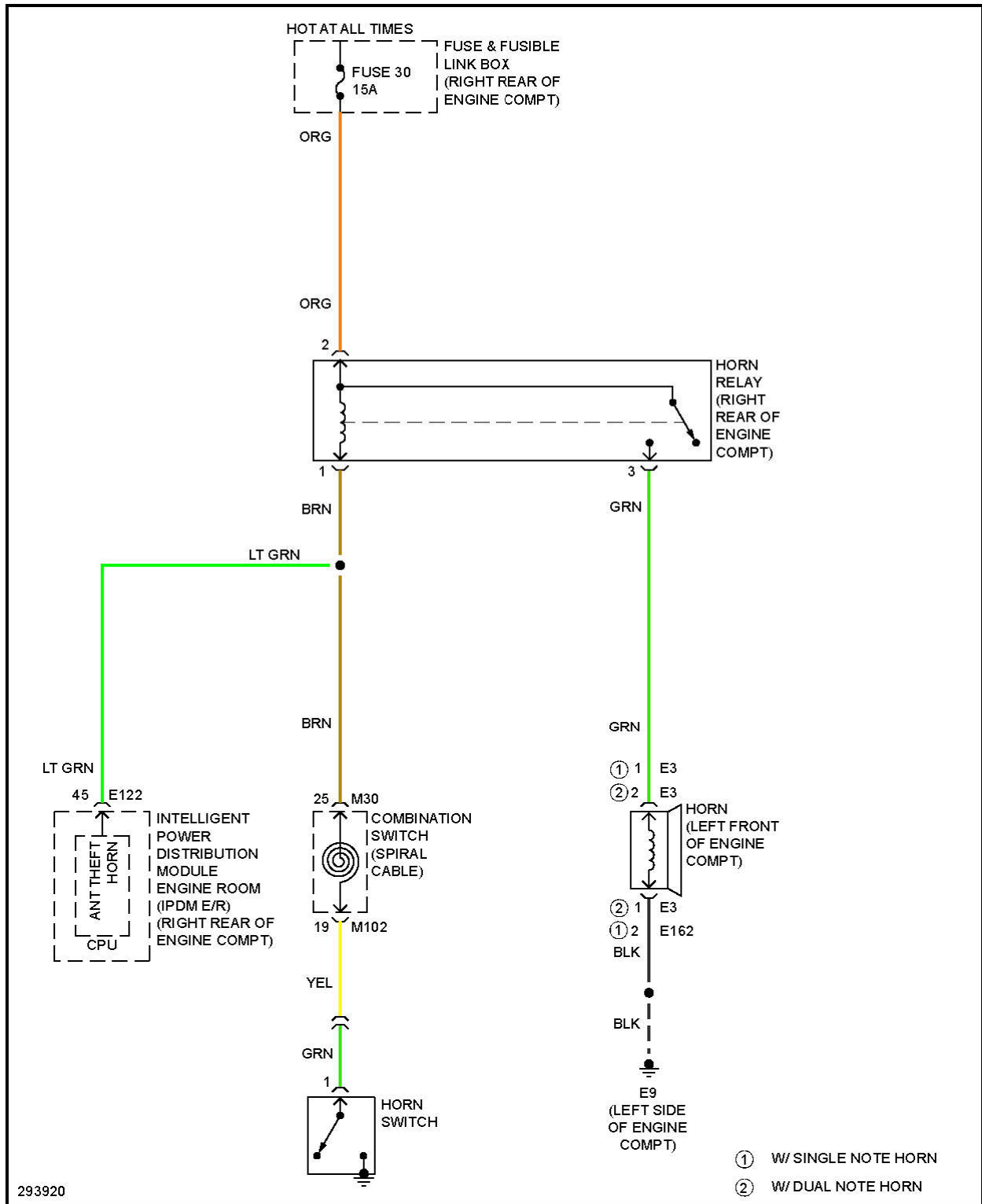

Fig. 32: Horn Circuit

2008 Nissan Frontier SE

2008 SYSTEM WIRING DIAGRAMS Nissan - Frontier

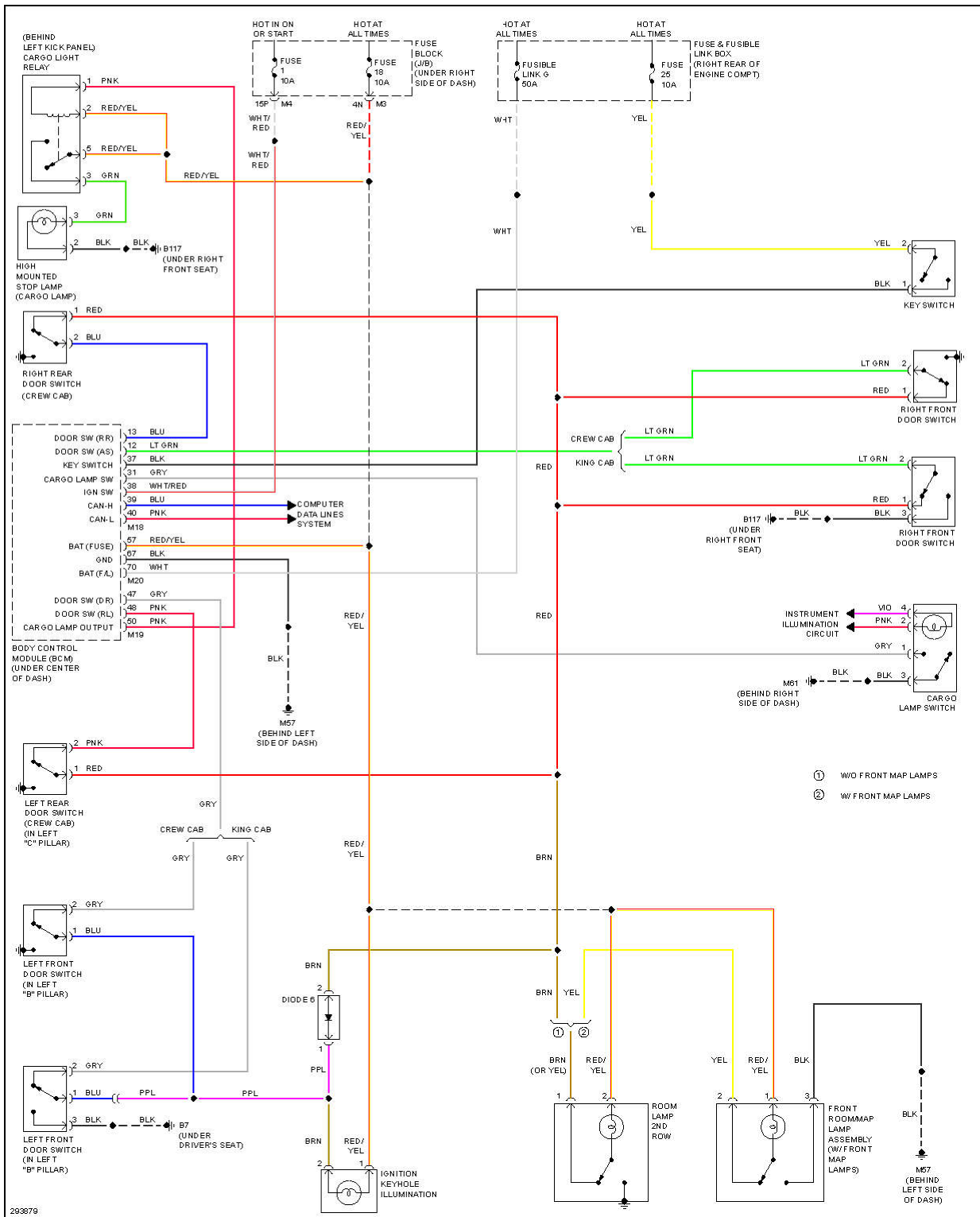

Fig. 36: Courtesy Lamps Circuit, W/O Power Door Locks

2008 Nissan Frontier SE

2008 SYSTEM WIRING DIAGRAMS Nissan - Frontier

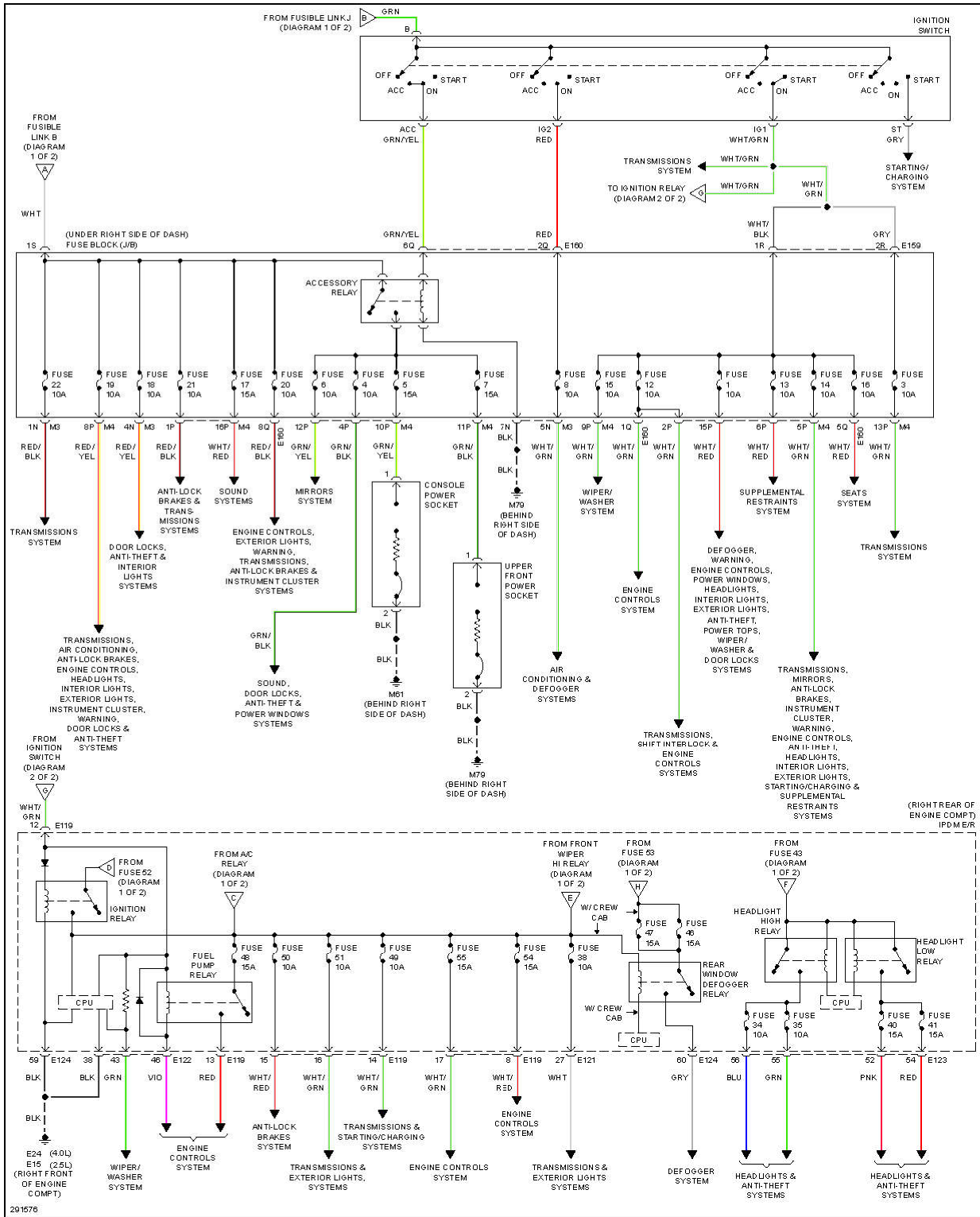

Fig. 39: Power Distribution Circuit (2 of 2)

2008 Nissan Frontier SE

2008 SYSTEM WIRING DIAGRAMS Nissan - Frontier

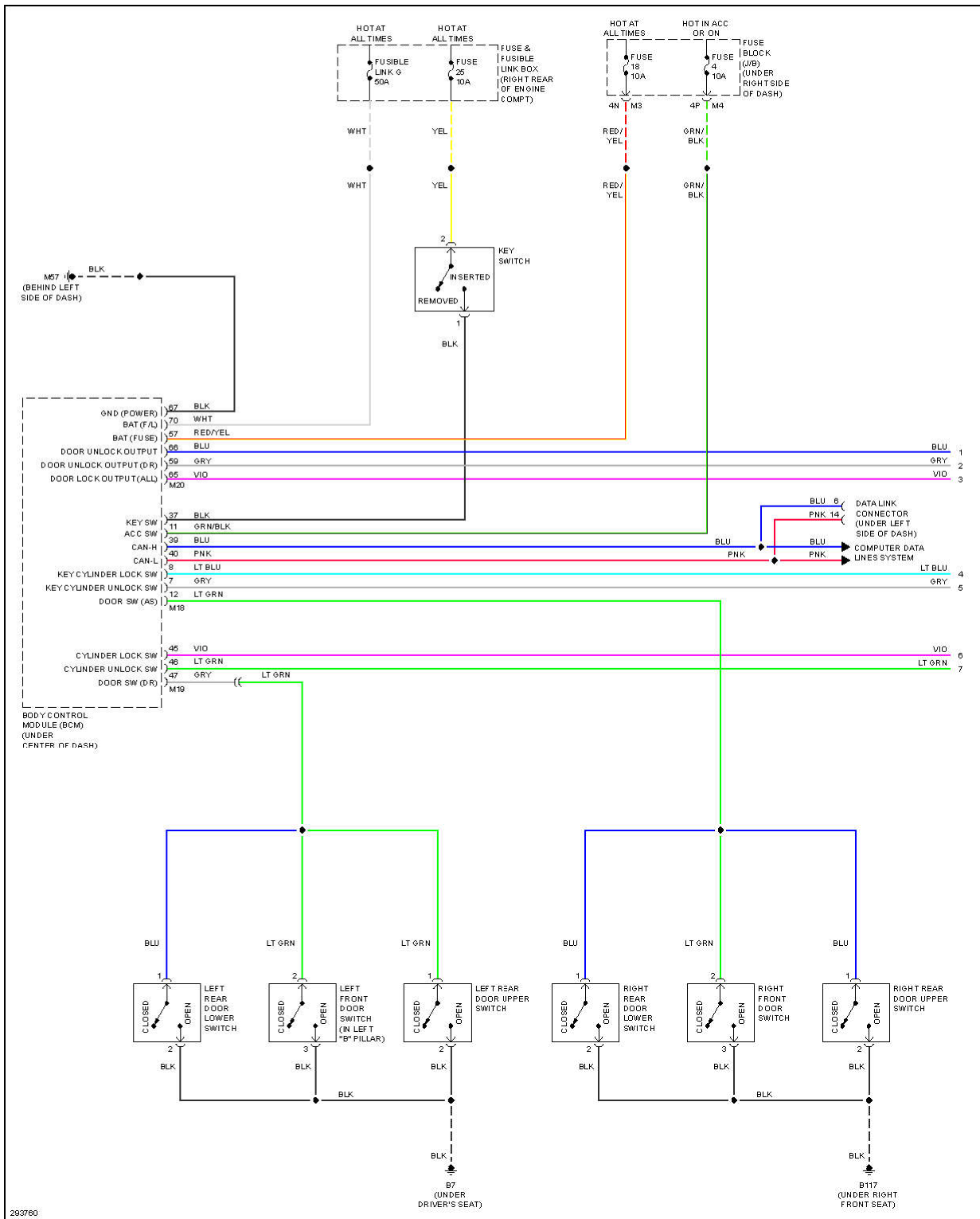

Fig. 46: Door Lock Circuit, King Cab (1 of 2)

2008 Nissan Frontier SE

2008 SYSTEM WIRING DIAGRAMS Nissan - Frontier

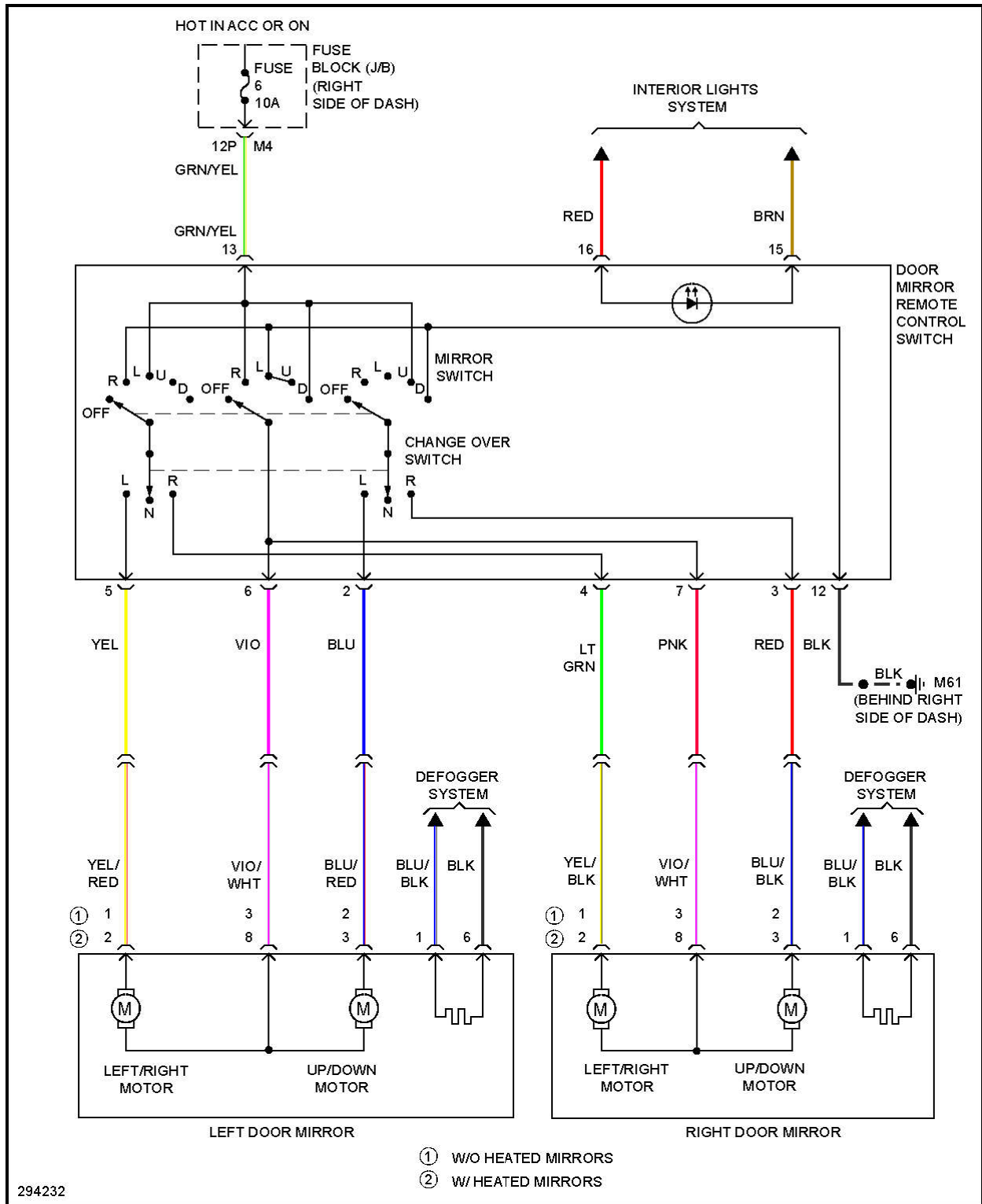

Fig. 49: Power Mirror Circuit

2008 Nissan Frontier SE

2008 SYSTEM WIRING DIAGRAMS Nissan - Frontier

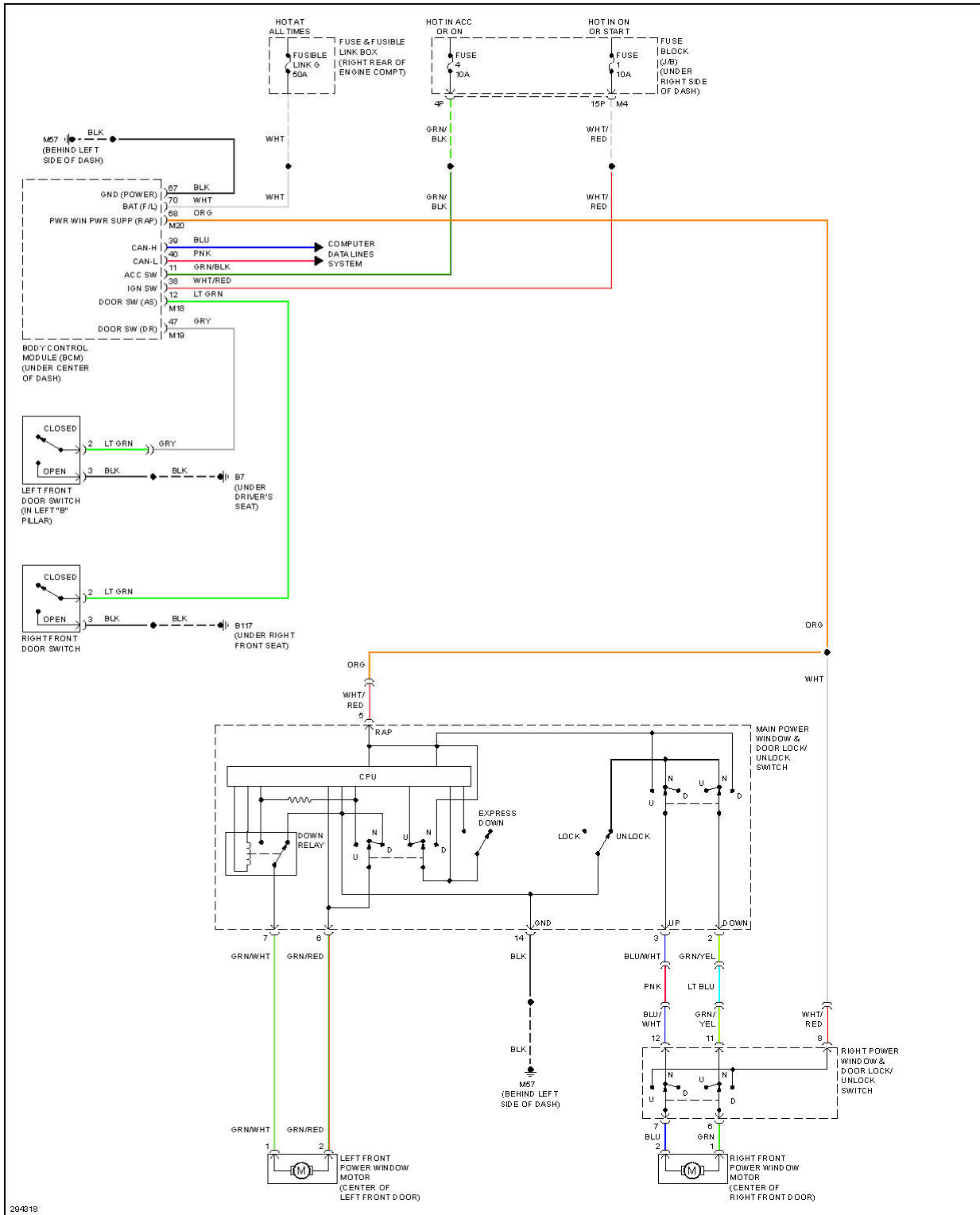

Fig. 54: Power Windows Circuit, King Cab

2008 Nissan Frontier SE

2008 SYSTEM WIRING DIAGRAMS Nissan - Frontier

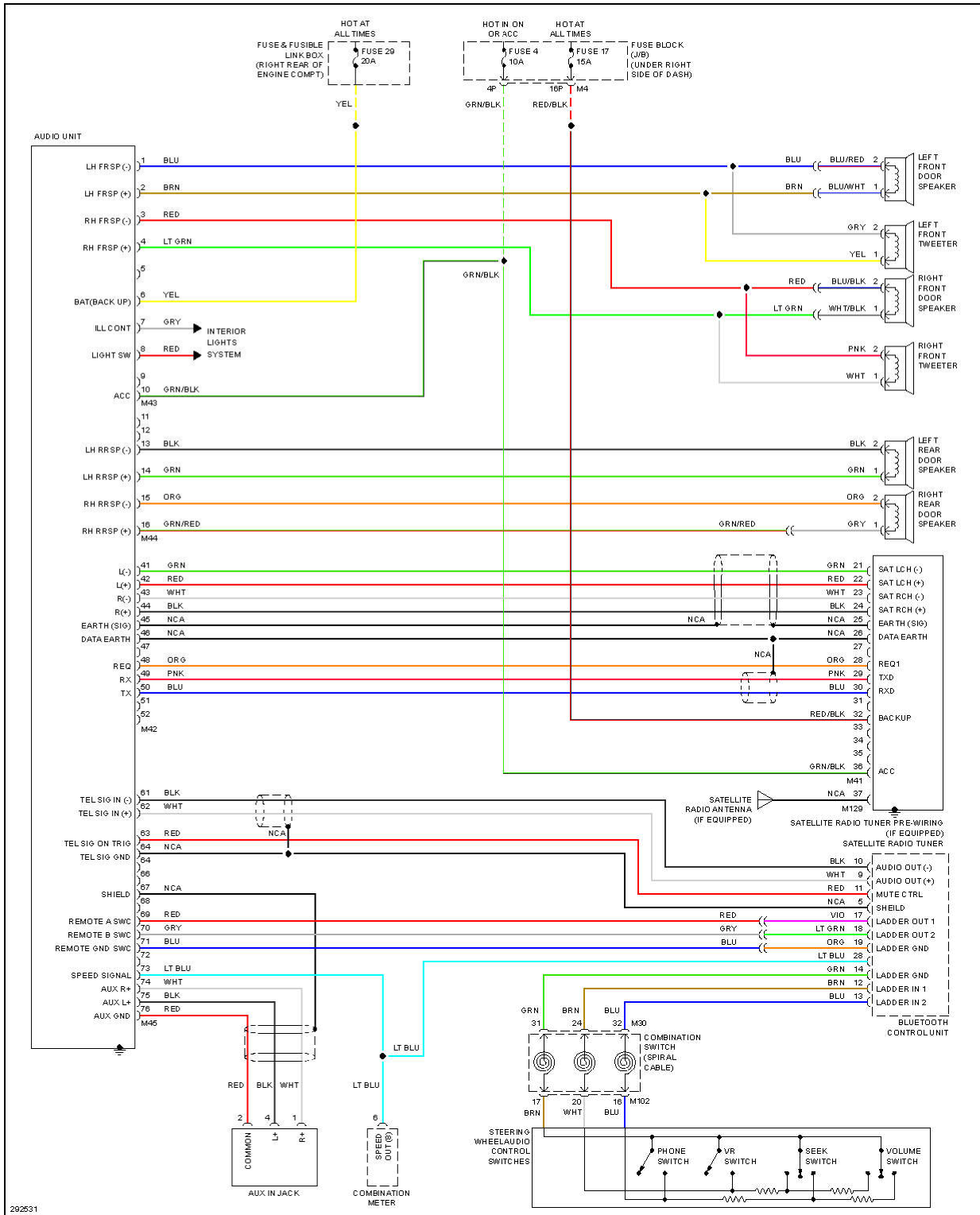

Fig. 58: Premium Sound Radio Circuit, King Cab

2008 Nissan Frontier SE

2008 SYSTEM WIRING DIAGRAMS Nissan - Frontier

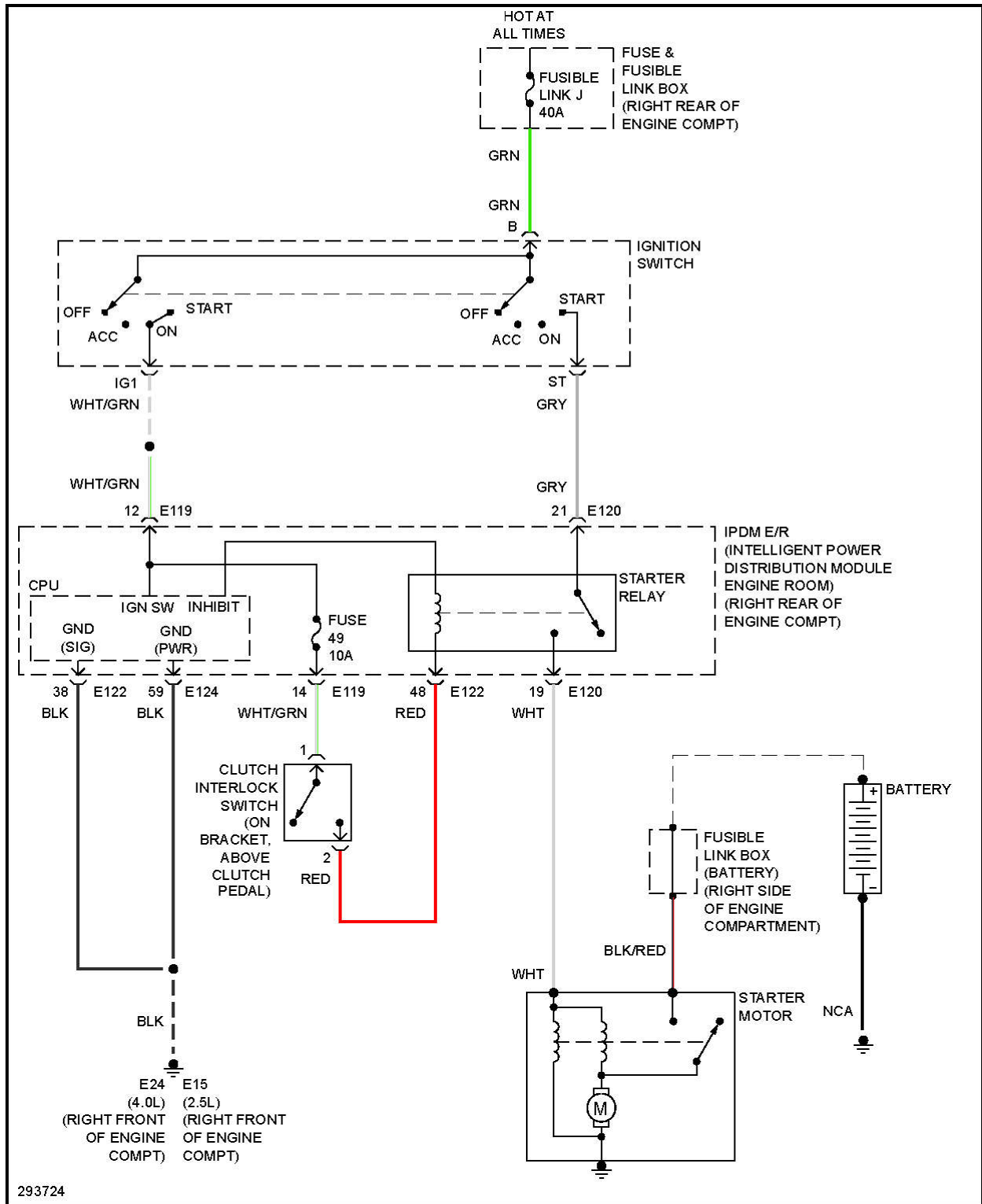

Fig. 63: Starting Circuit, M/T W/O Clutch Interlock

2008 Nissan Frontier SE

2008 SYSTEM WIRING DIAGRAMS Nissan - Frontier

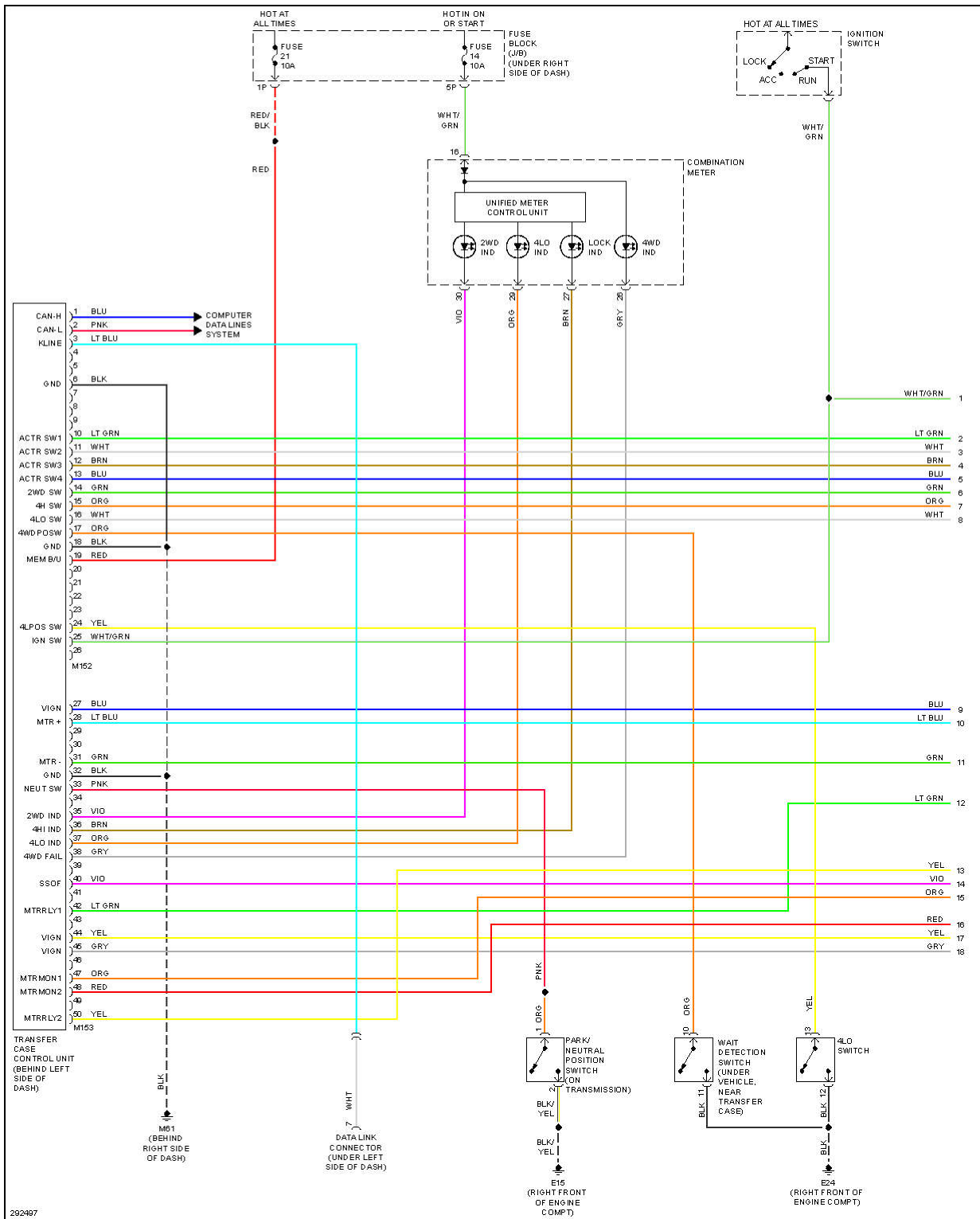

Fig. 68: 4WD Circuit, M/T (1 of 2)