

ELECTRICAL WIRING SCHEMATIC (WITHOUT ADVANCED KEYLESS SYSTEM)

00E-1a

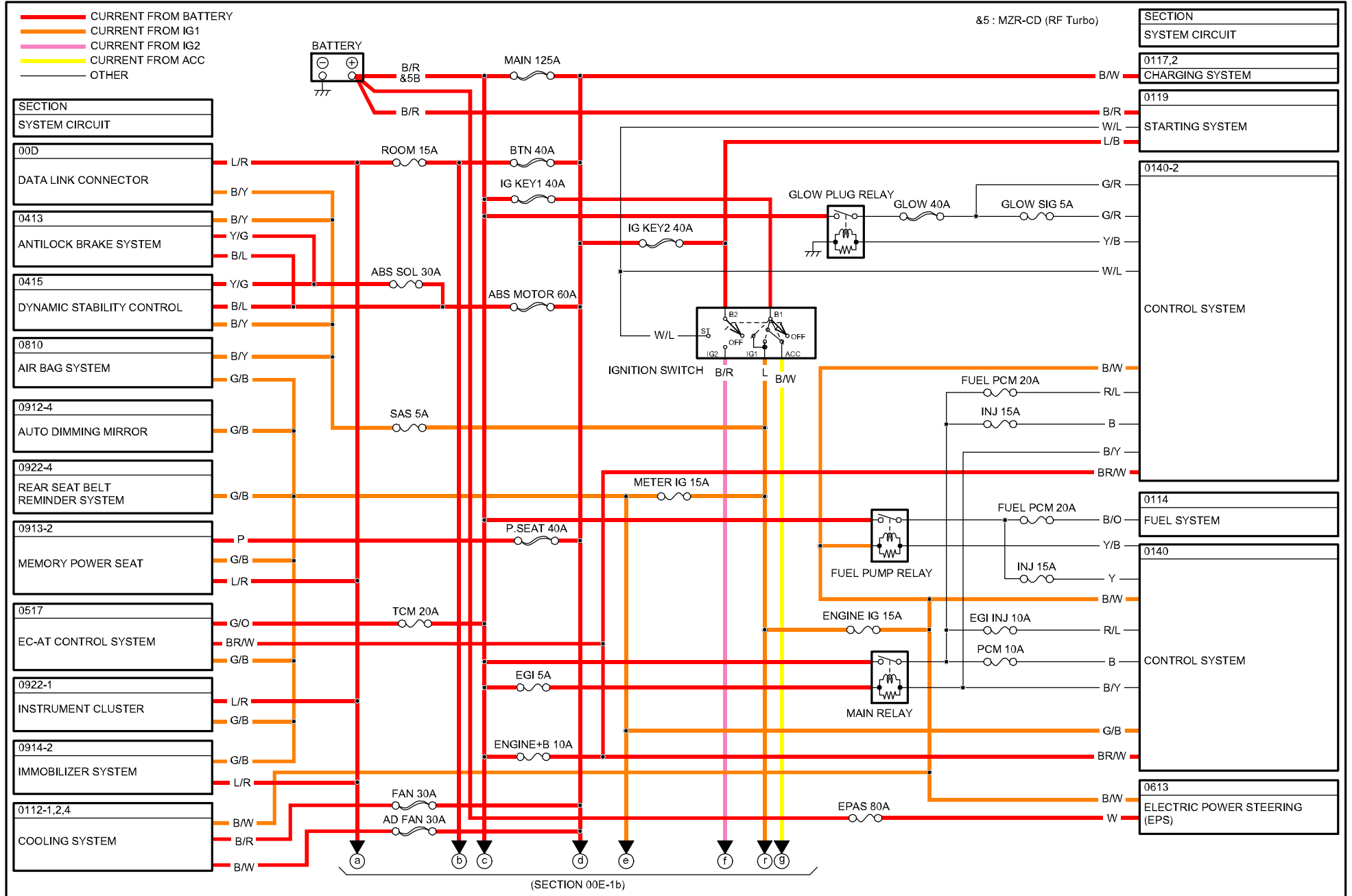

F-01
MAIN FUSE BLOCK

- < > : NOT USED
- () : IF EQUIPPED
- @2 : WITH ADVANCED KEYLESS SYSTEM
- @3 : WITH THREE COOLING FAN RELAYS
- @4 : WITH FOUR COOLING FAN RELAYS
- &5 : MZR-CD (RF Turbo)

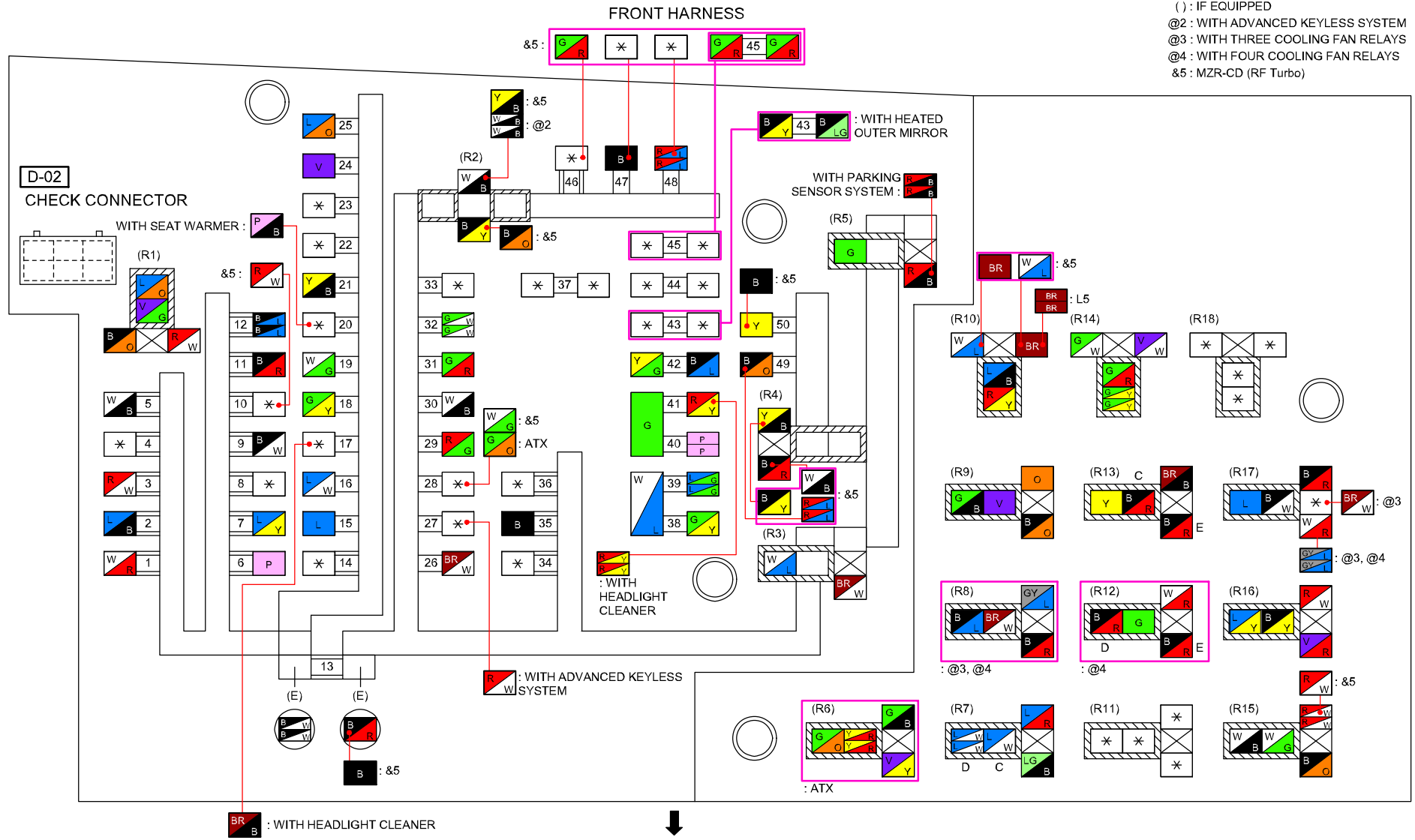

FRONT
NOTE: SEEN FROM TERMINAL SIDE

COOLING SYSTEM (WITH TWO COOLING FAN RELAYS / EXCEPT MZR-CD (RF Turbo))

0112-1b

{ } : NAME INDICATED ON FUSE BOX COVER

0112-1a

F-01 MAIN FUSE BLOCK

(SECTION 0112-1a)

a

AD FAN 30A

B/W(F)

B/R(F)

IGNITION SWITCH (IG1)
(SECTION 0112-1a)

4

COOLING FAN MOTOR NO.2

0112-102

0112-102

L(F)

B(F)

W/R(F)

7

PCM
(SECTION 0140-k)

B(F)

C-44

G03

G25

COOLING FAN RELAY NO.2
{AD FAN RELAY}

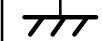

0112-102
COOLING FAN MOTOR NO.2

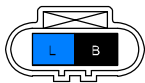

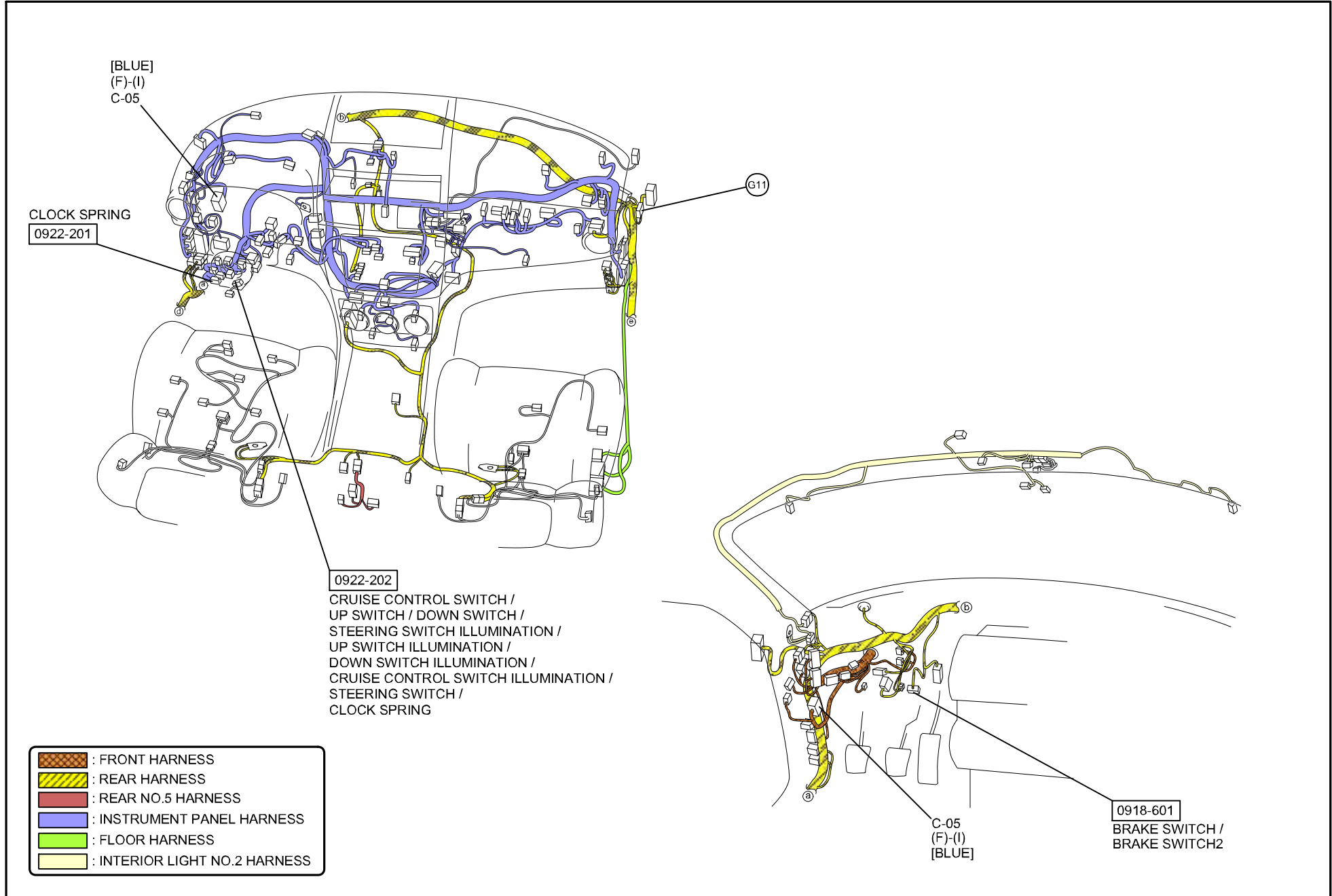

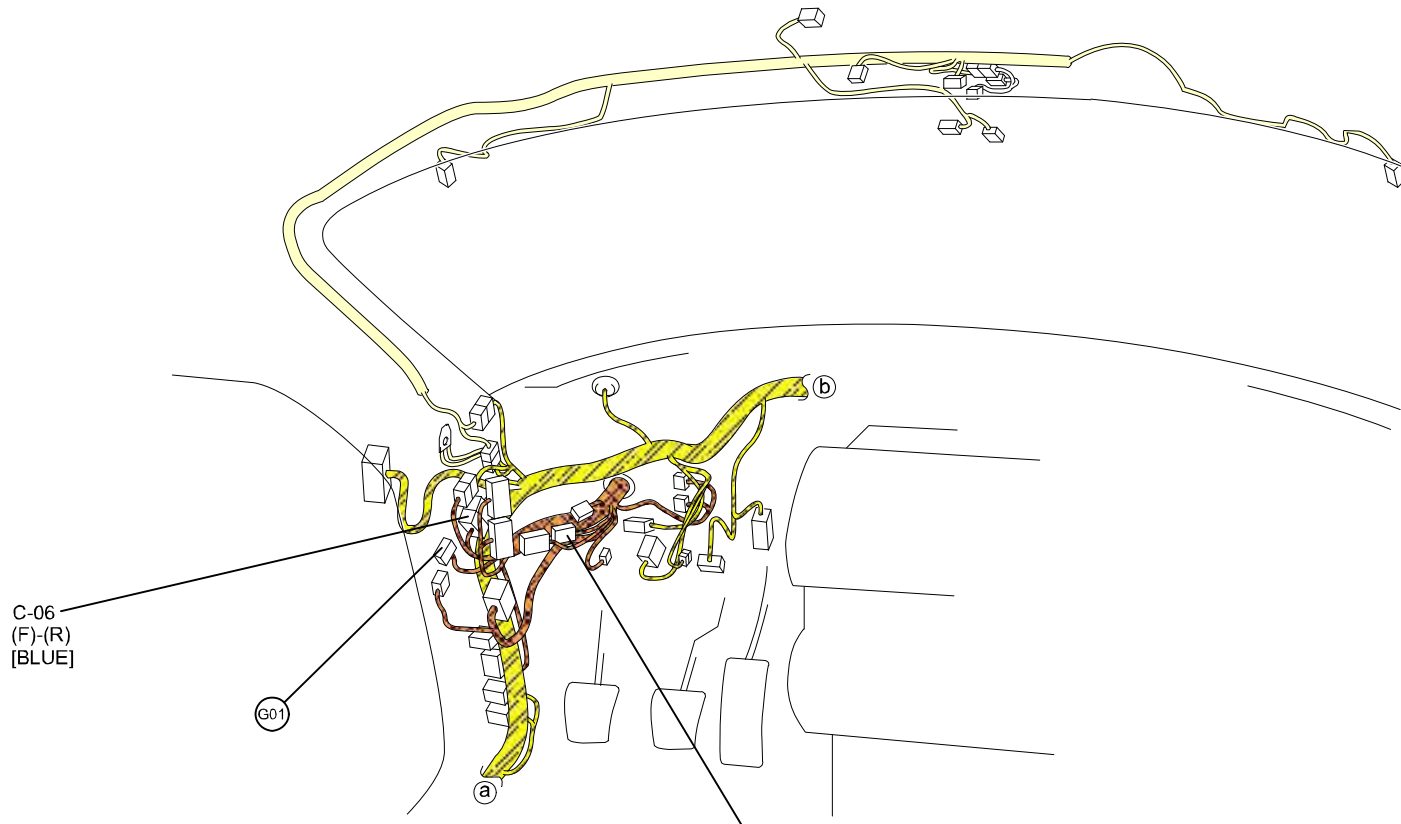



C-06
(F)-(R)
[BLUE]

G01

a

b

0140-201B
PCM
[BLACK]

-  : FRONT HARNESS
-  : REAR HARNESS
-  : INTERIOR LIGHT NO.2 HARNESS

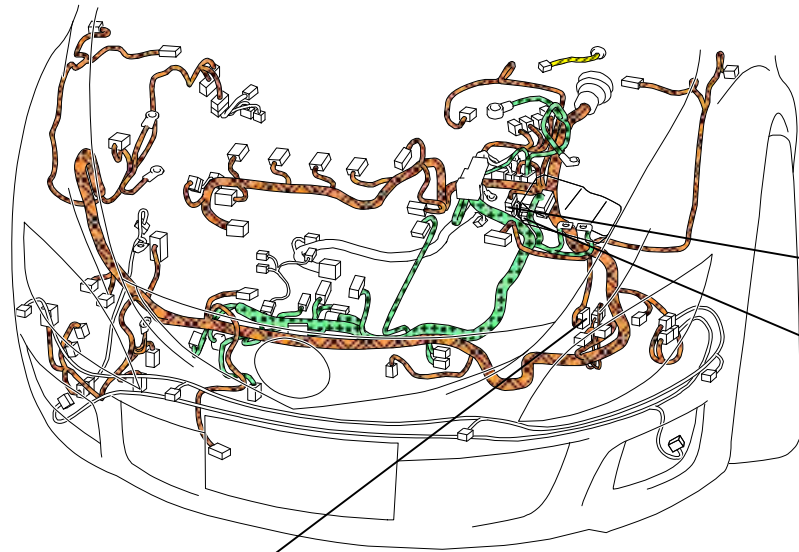





G02

C-61
(F)-SHORT CORD
[BLACK]

0140-227
EXHAUST GAS PRESSURE CORRECTION TEMPERATURE SENSOR
[BLACK]



0140-201A
PCM
[BLACK]

-  : FRONT HARNESS
-  : ENGINE HARNESS
-  : REAR HARNESS
-  : INTERIOR LIGHT NO.2 HARNESS

[BLACK]
REFRIGERANT PRESSURE SWITCH

0740-211

G25

G03

C-44
(F)-SHORT CORD
[GRAY]

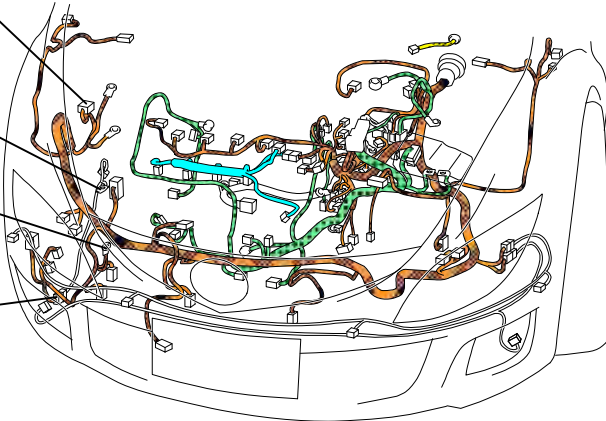

[EXCEPT MZR-CD (RF Turbo)]

[BLACK]
REFRIGERANT PRESSURE SWITCH

0740-211

G25

G03

C-44
(F)-SHORT CORD
[GRAY]

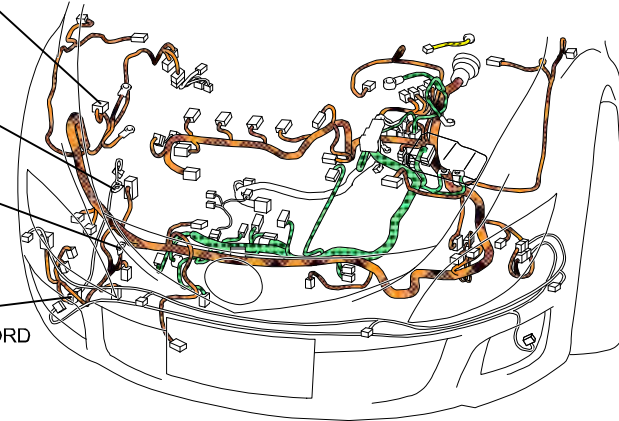

[MZR-CD (RF Turbo)]

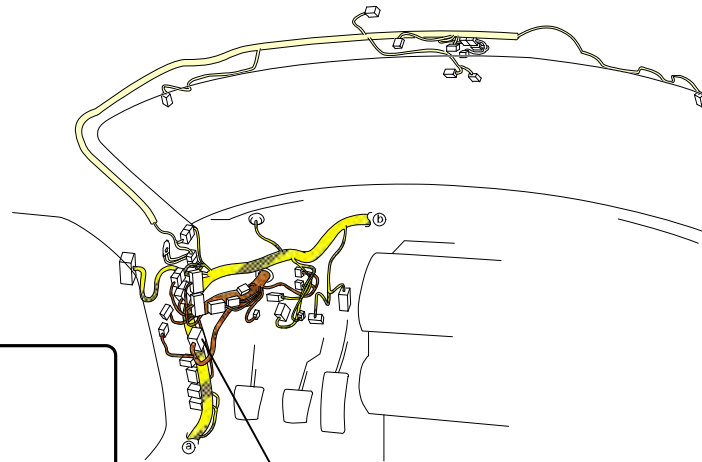

C-05
(F)-(I)
[BLUE]

- : FRONT HARNESS
- : ENGINE HARNESS
- : INJECTION HARNESS
- : REAR HARNESS
- : REAR NO.5 HARNESS
- : INSTRUMENT PANEL HARNESS
- : FLOOR HARNESS
- : INTERIOR LIGHT NO.2 HARNESS

[BLUE]
(F)-(I)
C-05

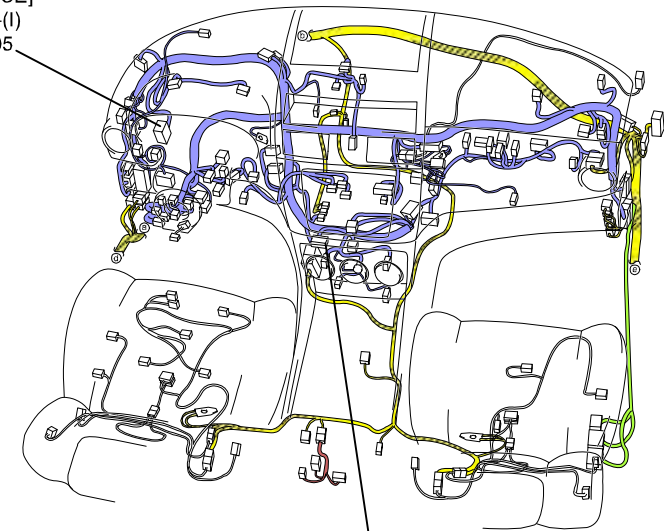

0740-201A

CLIMATE CONTROL UNIT

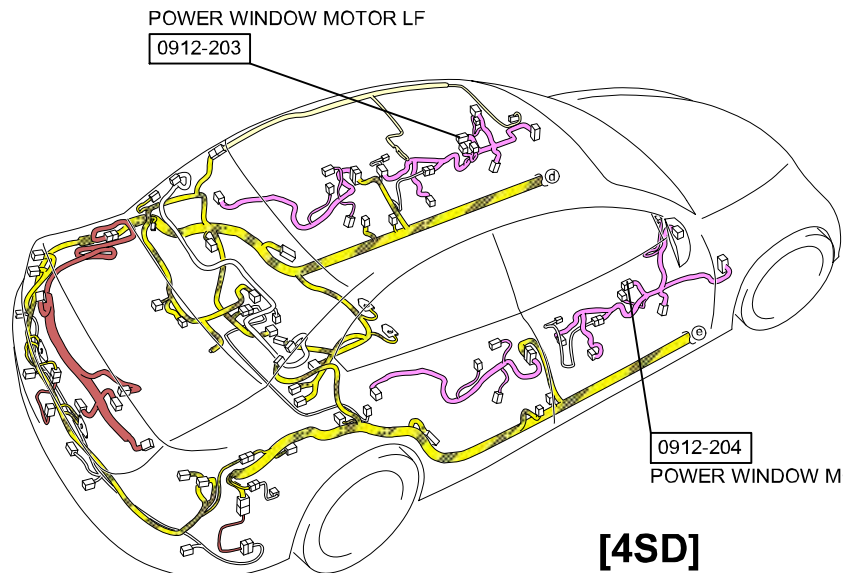

[4SD]

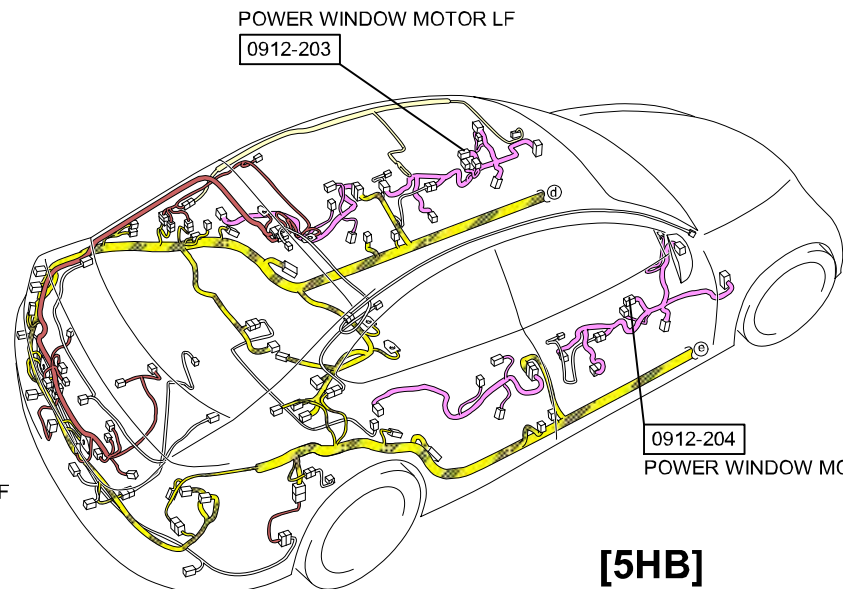

[5HB]

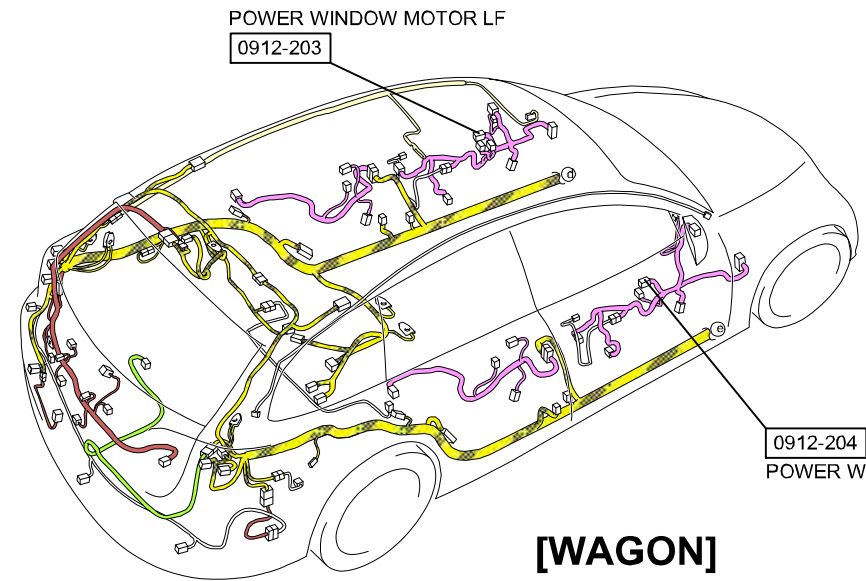

[WAGON]

- : REAR HARNESS
- : REAR NO.2 HARNESS
REAR NO.3 HARNESS
REAR NO.4 HARNESS
- : DOOR HARNESS
- : INTERIOR LIGHT HARNESS
- : FLOOR HARNESS

POWER WINDOW SYSTEM (European (L.H.D.) specs.)

0912-2g

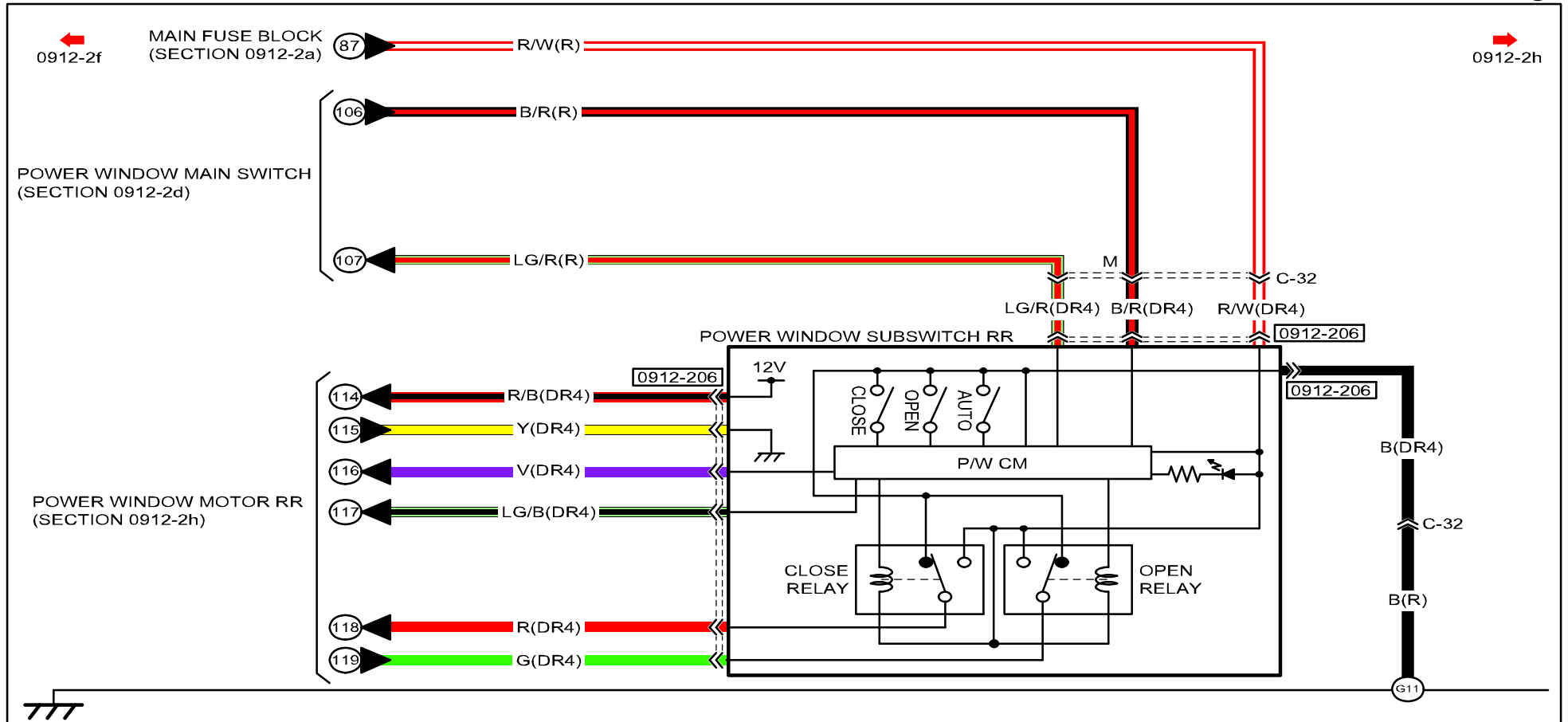

0912-206
POWER WINDOW SUBSWITCH RR

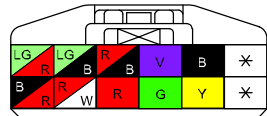

C-35
REAR HARNESS-REAR NO.2 HARNESS

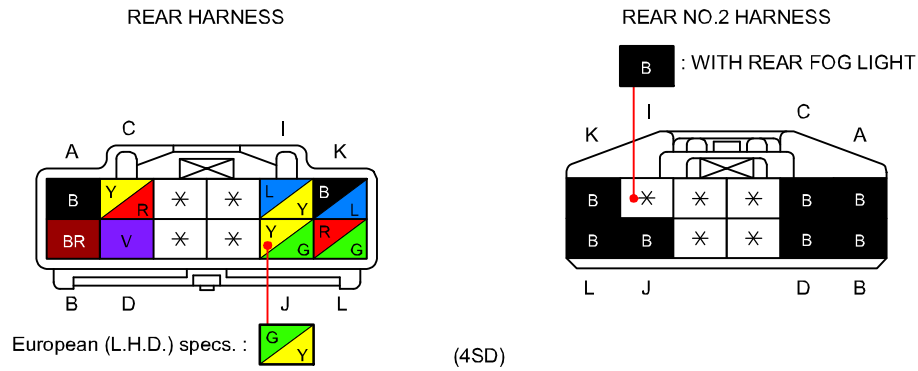

C-36
REAR HARNESS-REAR NO.3 HARNESS

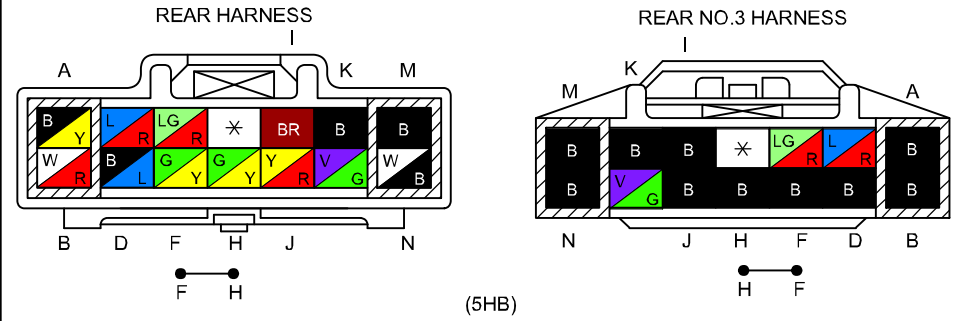

C-37
REAR HARNESS-REAR NO.3 HARNESS

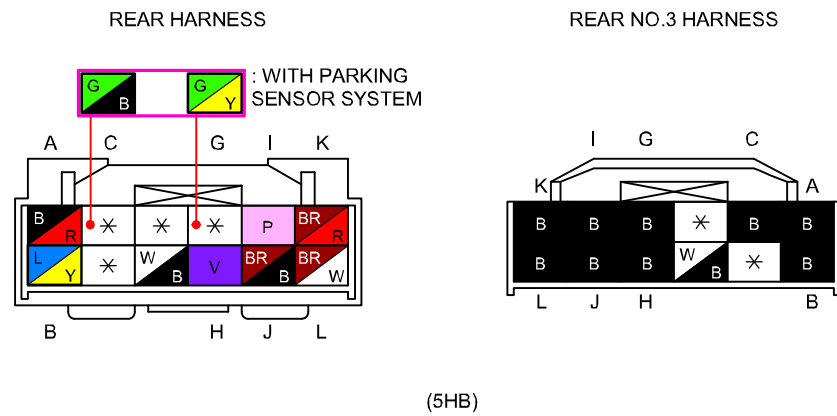

C-41
REAR NO.2 HARNESS-REAR NO.3 HARNESS

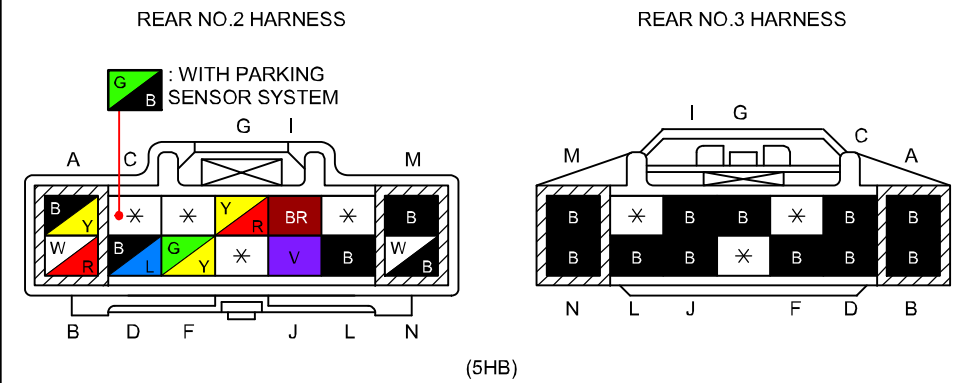

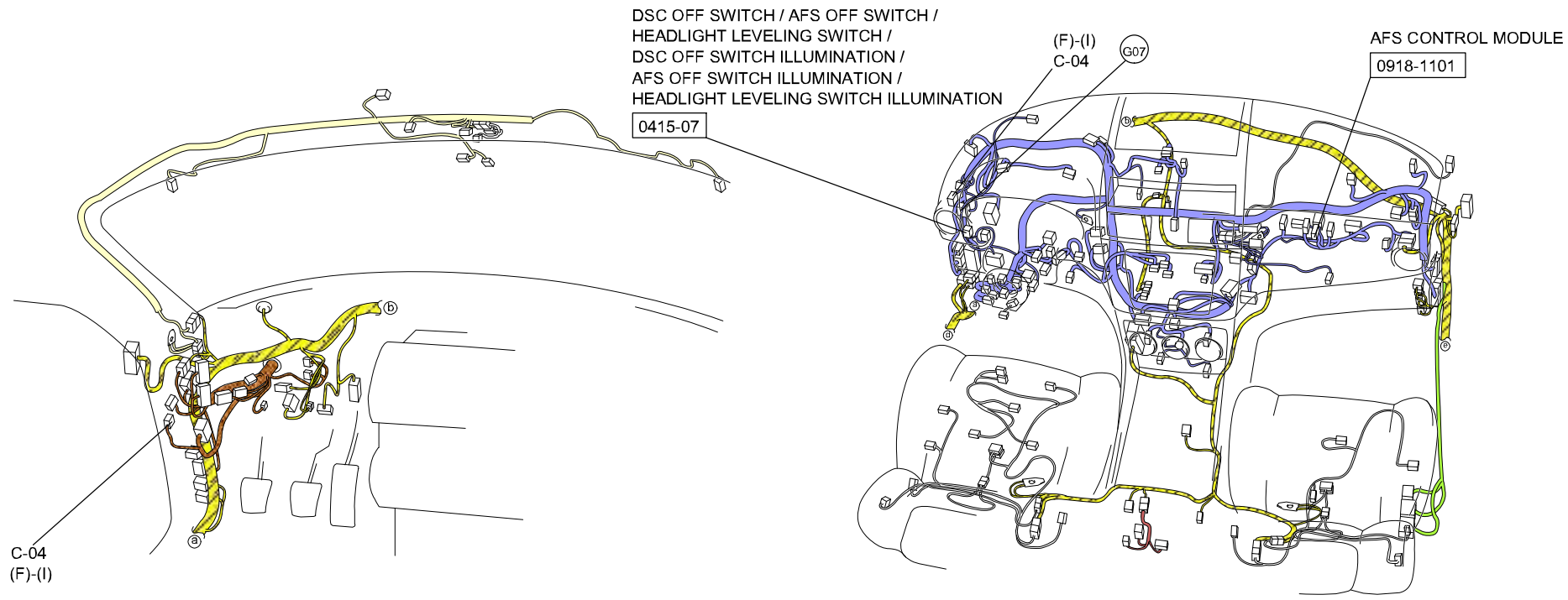

- : FRONT HARNESS
- : REAR HARNESS
- : REAR NO.5 HARNESS
- : INSTRUMENT PANEL HARNESS
- : FLOOR HARNESS
- : INTERIOR LIGHT NO.2 HARNESS

C-05

FRONT HARNESS-INSTRUMENT PANEL HARNESS

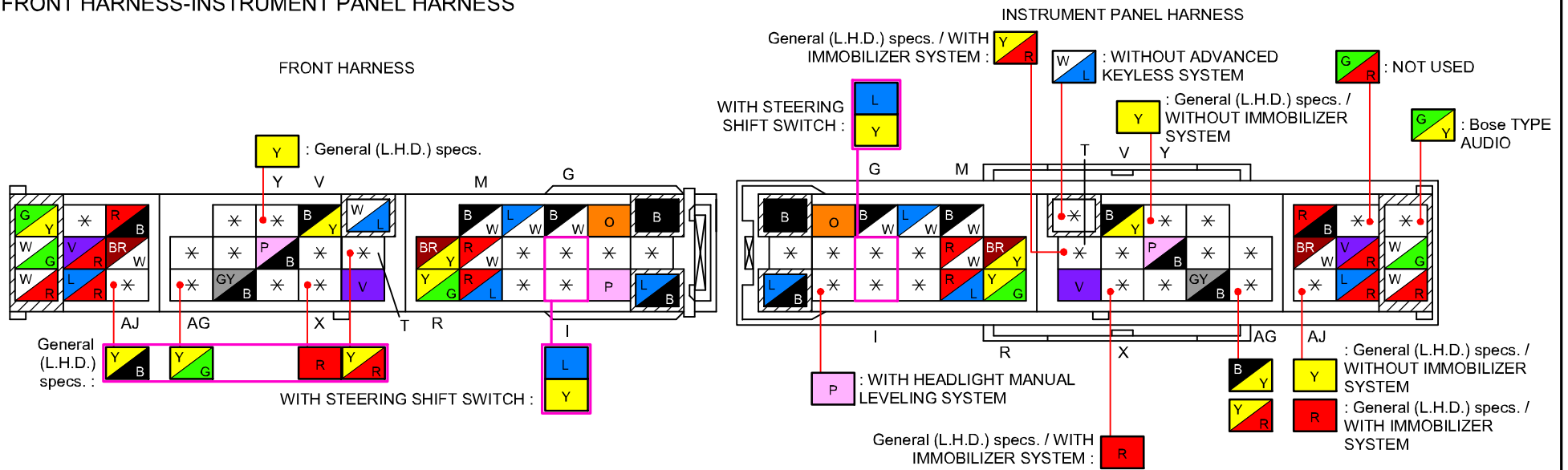

@1 : WITHOUT ADVANCED KEYLESS SYSTEM
 @2 : WITH ADVANCED KEYLESS SYSTEM

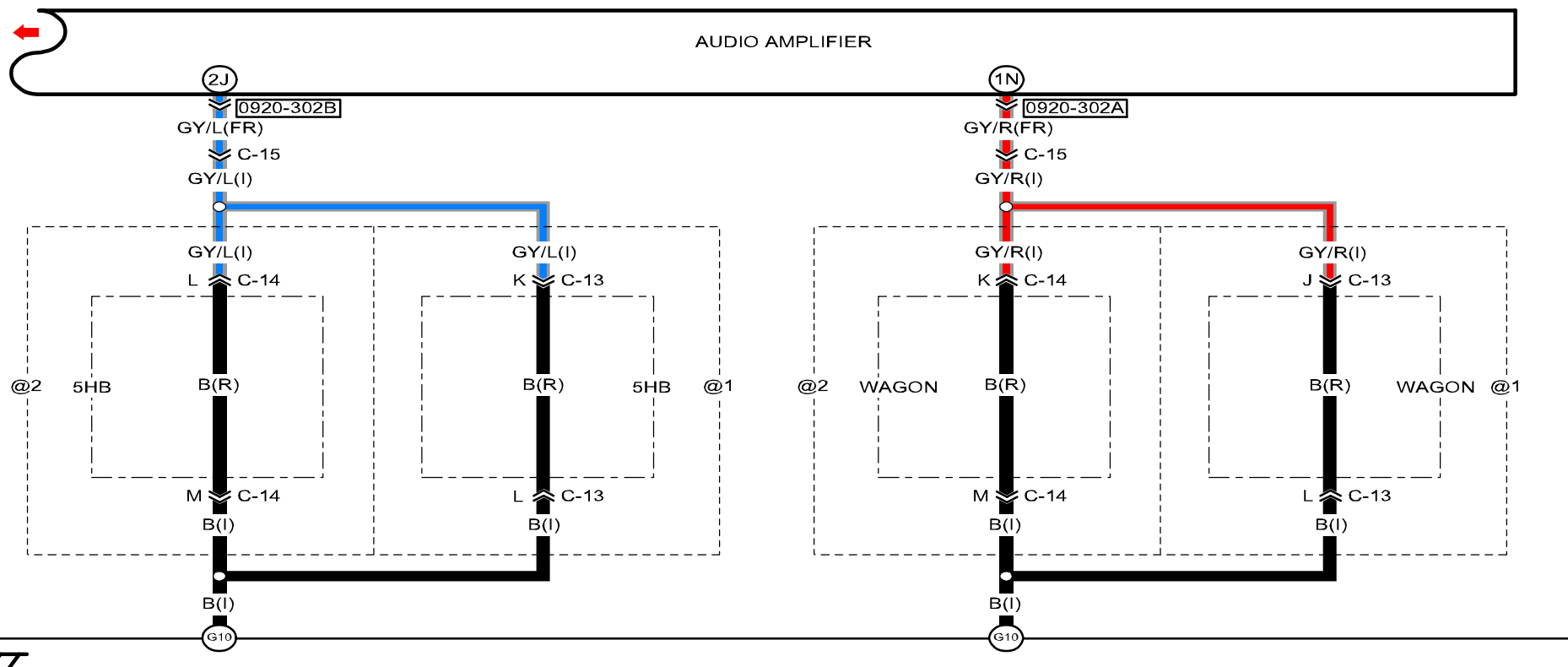

0920-302A
 AUDIO AMPLIFIER

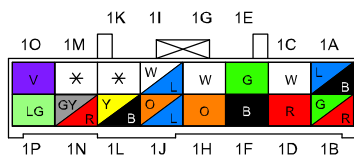

0920-302B
 AUDIO AMPLIFIER

