

ABS AND TRACTION CONTROL

FROM POWER SOURCE SYSTEM (SEE PAGE 56)

* 1 : SHIELDED

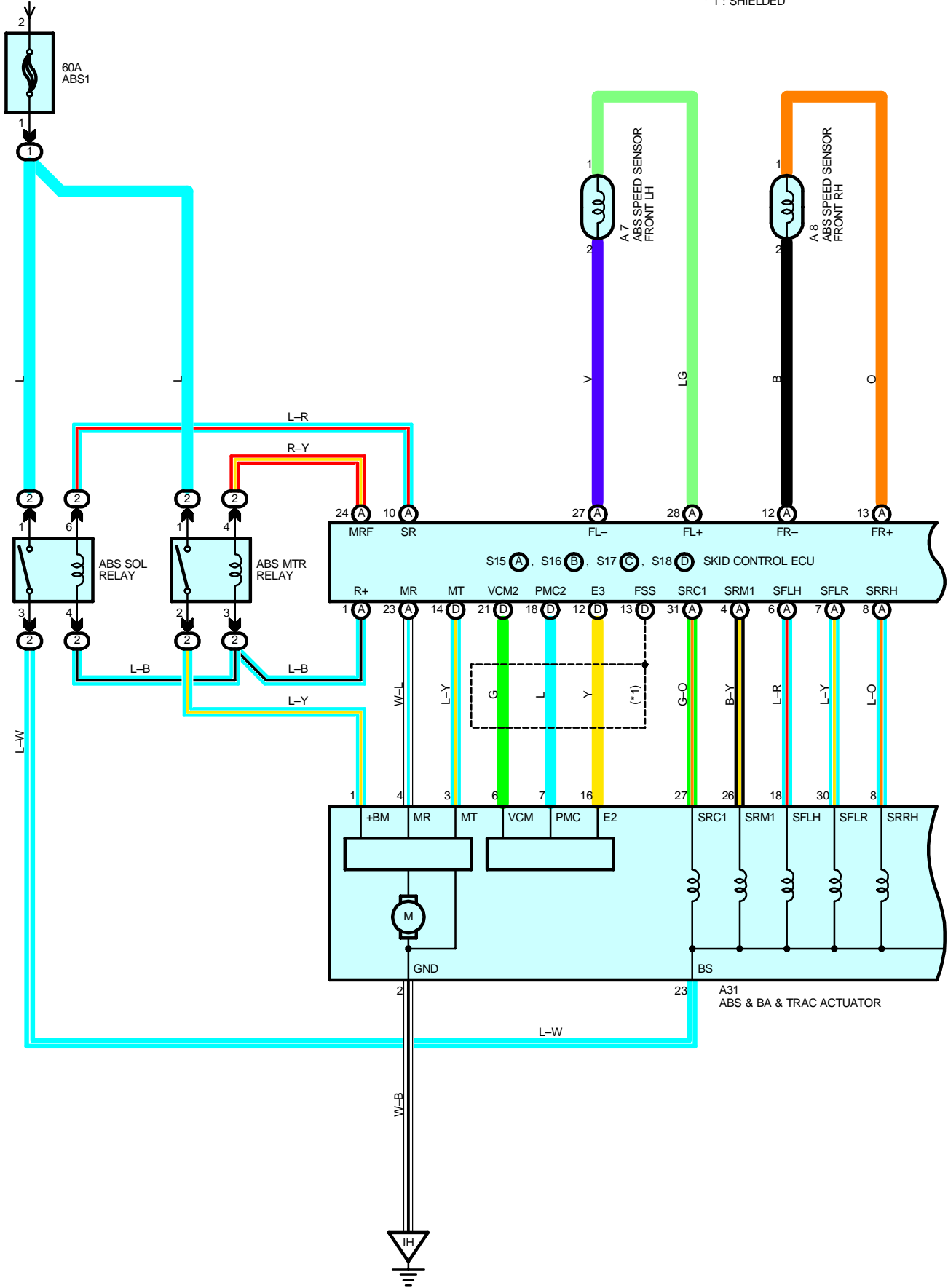

ABS AND TRACTION CONTROL

SYSTEM OUTLINE

1. ABS OPERATION

If the brake pedal is depressed suddenly, the ABS controls the hydraulic pressure of the wheel cylinders for all the four wheels to automatically avoid wheel locking and ensure the directional and steering stability of the vehicle. If the brake pedal is depressed suddenly, the skid control ECU controls the solenoids in the actuators using the signals from the sensors to move the brake fluid to the reservoir in order to release the braking pressure applied to the wheel cylinder. If the skid control ECU detects that the fluid pressure in the wheel cylinder is insufficient, the ECU controls the solenoids in the actuators to increase the braking pressure.

2. TRACTION CONTROL OPERATION

The traction control system controls the engine torque, the hydraulic pressure of the driving wheel cylinders, slipping of the wheels which may occur at start or acceleration of the vehicle, to ensure an optimal driving power and vehicle stability corresponding to the road conditions.

Traction control SW

The traction control SW is used to stop the TRAC function. After the engine is started, the TRAC system is stopped (turned off) and the TRAC OFF indicator light lights up. When the traction control SW is pressed again, the TRAC system enters the stand-by mode. If the engine is stopped and restarted, the TRAC system enters the stand-by mode regardless of the traction control SW.

SERVICE HINTS

S15 (A), S16 (B), S18 (D) SKID CONTROL ECU

IG1-GROUND : 10-14 volts with the ignition SW at ON position

STP-GROUND : 0-1.5 volts with the stop light SW off

: 8-14 volts with the stop light SW on

GND1, GND2, GND3, GND4-GROUND : Always continuity

S8 STOP LIGHT SW

2-1 : Closed with the brake pedal depressed

A7, A8 ABS SPEED SENSOR FRONT LH, RH

1-2 : Approx. 1.6 kΩ at 20°C (68°F)

A29, A30 ABS SPEED SENSOR REAR LH, RH

1-2 : Approx. 1.0 kΩ at 25°C (77°F)

○ : PARTS LOCATION

Code	See Page	Code	See Page	Code	See Page
A7	32	C9 A	34	S8	35
A8	32	C10 B	34	S15 A	35
A12	34	D5	34	S16 B	35
A29	36 (S/D)	E4	32	S17 C	35
	38 (W/G)	H15	35	S18 D	35
A30	36 (S/D)	J2	33	T7 A	35
	38 (W/G)	J5	35	T14 B	35
A31	32	J6	35	V9	33
B1	32	J7	35		
B10	34	P3	35		

○ : RELAY BLOCKS

Code	See Page	Relay Blocks (Relay Block Location)
1	22	Engine Room No.1 R/B (Engine Compartment Right)
2	22	Engine Room No.2 R/B (Engine Compartment Right)

 : CONNECTOR JOINING WIRE HARNESS AND WIRE HARNESS

Code	See Page	Joining Wire Harness and Wire Harness (Connector Location)
EA1	42	Engine Wire and Engine Room Main Wire (Inside of the ECU Box)
IA3	44	Instrument Panel Wire and Engine Room Main Wire (Near the Driver Side J/B)
IG1	46	Instrument Panel Wire and Engine Room Main Wire (Near the Passenger Side J/B)
IG2		
IG3		
BG1	52	Floor No.2 Wire and Front Seat LH Wire (Under the Driver's Seat)
BH1	52	Floor Wire and Front Seat RH Wire (Under the Front Passenger's Seat)

 : GROUND POINTS

Code	See Page	Ground Points Location
EB	42	Center Side of the Intake Manifold
EC	42	Left Fender Apron
ID	44	Cowl Side Panel LH
IH	44	Cowl Side Panel RH
BJ	48 (S/D)	Front Floor Panel LH
	50 (W/G)	
BK	48 (S/D)	Front Floor Panel RH
	50 (W/G)	
BL	48 (S/D)	Left Quarter Panel LH

SERVICE HINTS**I14 COMPASS [INNER MIRROR]**1-GROUND : Approx. 12 volts with the ignition SW at **ON** position

4-GROUND : Always continuity

○ : PARTS LOCATION

Code	See Page	Code	See Page	Code	See Page
I14	36 (S/D)	W4	37 (S/D)		
	38 (W/G)		39 (W/G)		

○ : JUNCTION BLOCK AND WIRE HARNESS CONNECTOR

Code	See Page	Junction Block and Wire Harness (Connector Location)
1N	24	Roof Wire and Driver Side J/B (Left Kick Panel)

□ : CONNECTOR JOINING WIRE HARNESS AND WIRE HARNESS

Code	See Page	Joining Wire Harness and Wire Harness (Connector Location)
IJ1	46	Roof Wire and Floor No.2 Wire (Left Side of the Instrument Panel)

▽ : GROUND POINTS

Code	See Page	Ground Points Location
BJ	48 (S/D)	Front Floor Panel LH
	50 (W/G)	

K CONNECTOR LIST

A 1
Black



A 2
Black



A 3
Gray

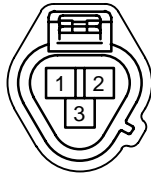

A 4
Black

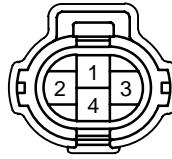

A 7
Gray



A 8
Gray



A 9
Black



A10
Yellow



A11
Yellow



A12

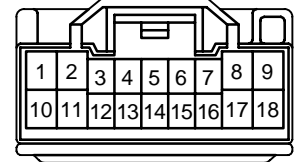

A13
Black

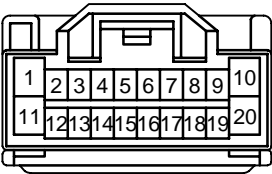

A14
Black

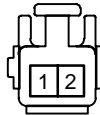

A15
Black



A21

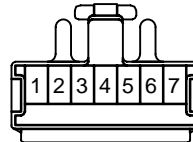

A22
Black

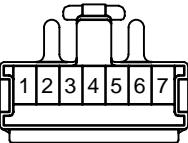

A23

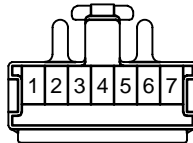

A24
Yellow



A25
Yellow

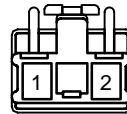

A26



A27

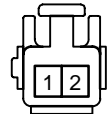

A28

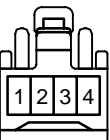

A29
(S/D) Gray



A29
(W/G) Gray



A30
(S/D)



A30
(W/G)



A31
Black

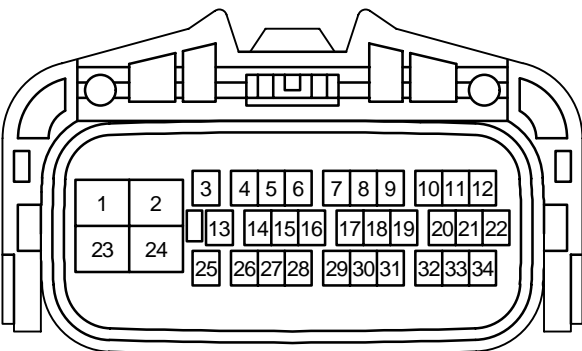

A32
Black

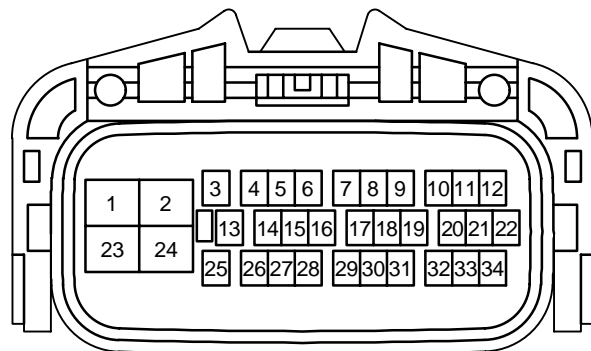

G ELECTRICAL WIRING ROUTING

Position of Parts in Seat

*1 : w/ Power Seat

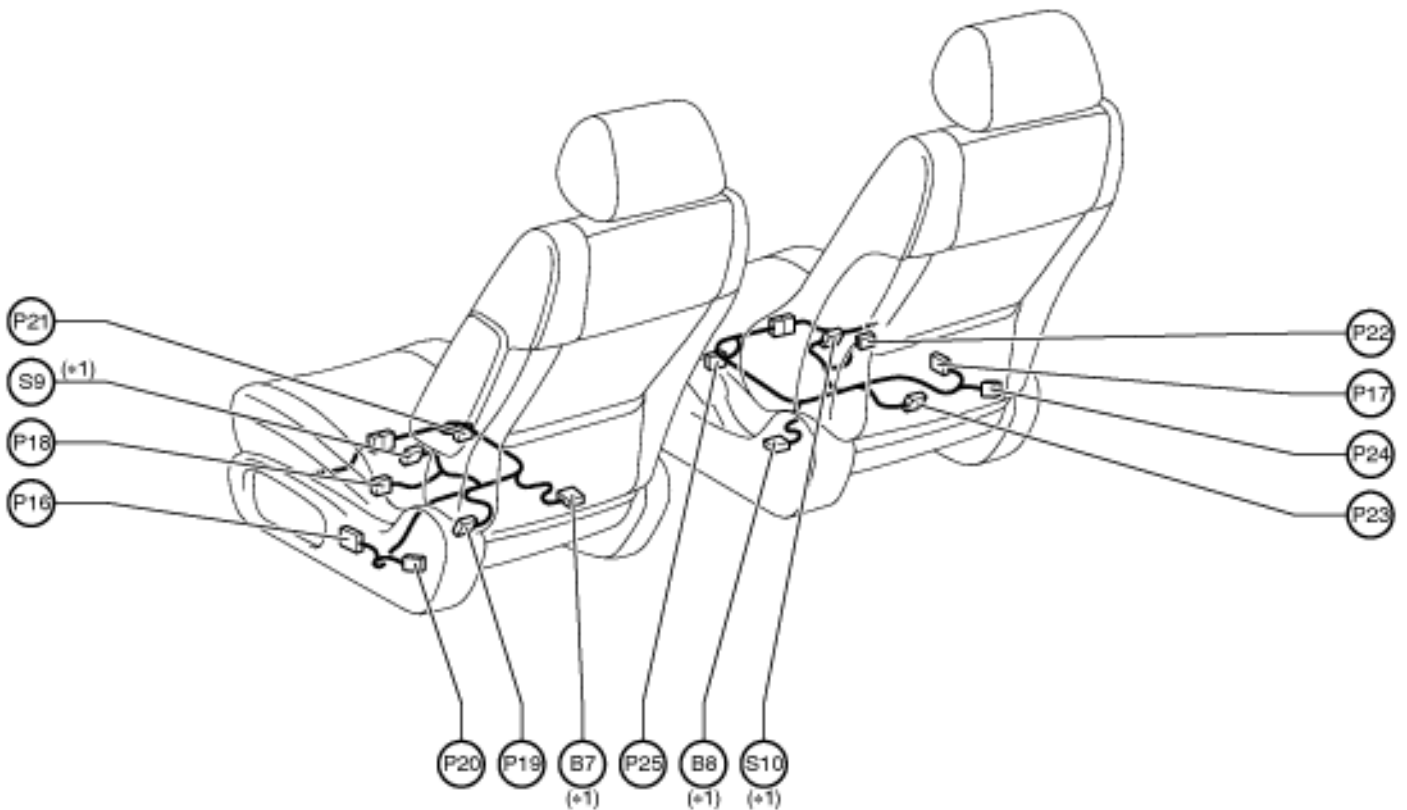

B 7 Buckle SW LH
 B 8 Buckle SW RH and
 Seat Belt Warning Occupant Detection Sensor

S 9 Seat Heater (Driver's Seat)
 S10 Seat Heater (Front Passenger's Seat)

P16 Power Seat Control SW (Driver's Seat)
 P17 Power Seat Control SW (Front Passenger's Seat)
 P18 Power Seat Motor (Driver's Seat Front Vertical Control)
 P19 Power Seat Motor (Driver's Seat Rear Vertical Control)
 P20 Power Seat Motor (Driver's Seat Reclining Control)
 P21 Power Seat Motor (Driver's Seat Slide Control)
 P22 Power Seat Motor
 (Front Passenger's Seat Front Vertical Control)
 P23 Power Seat Motor
 (Front Passenger's Seat Rear Vertical Control)
 P24 Power Seat Motor
 (Front Passenger's Seat Reclining Control)
 P25 Power Seat Motor
 (Front Passenger's Seat Slide Control)

FROM POWER SOURCE SYSTEM (SEE PAGE 56)

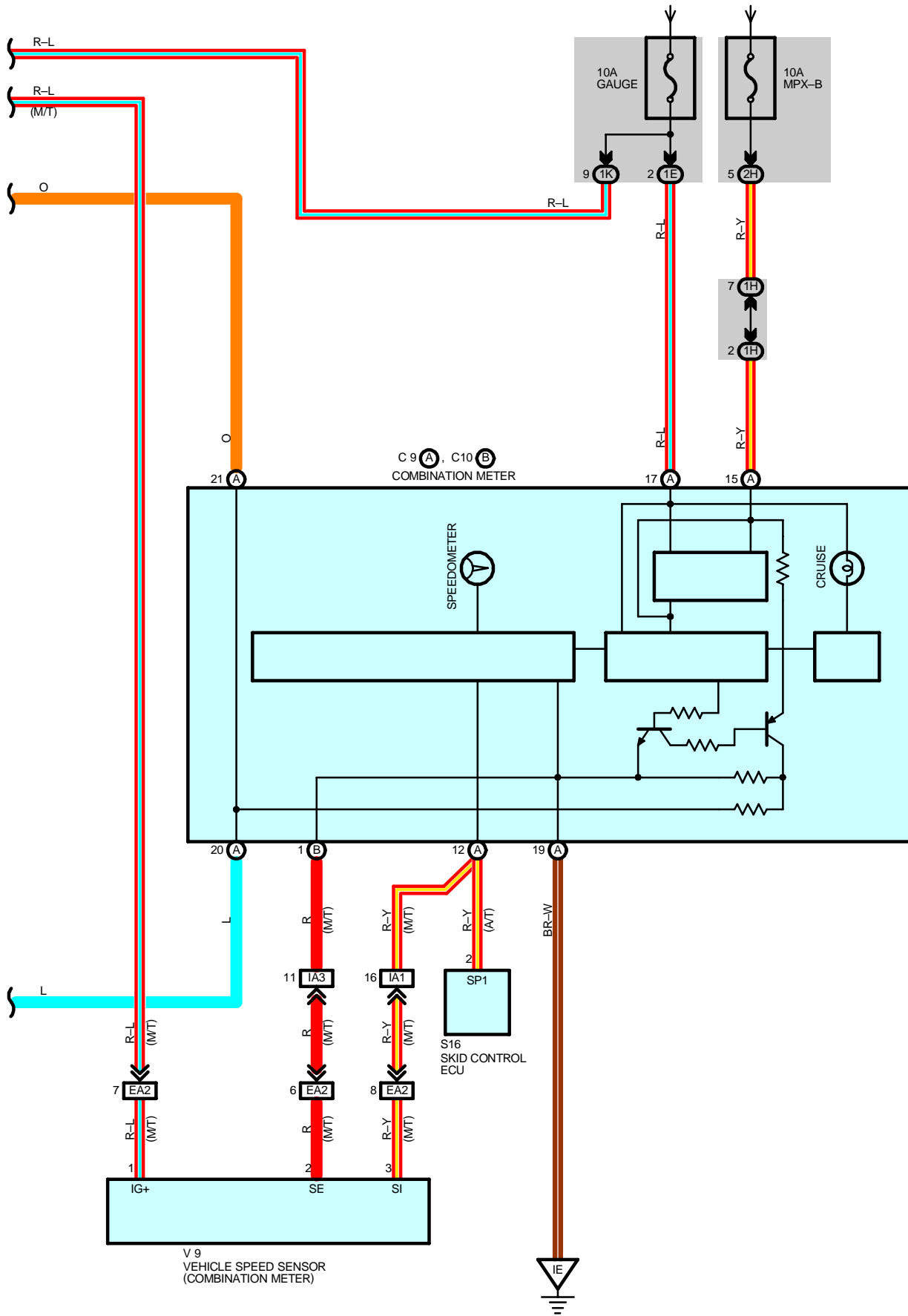

FRONT FOG LIGHT

FROM POWER SOURCE SYSTEM (SEE PAGE 56)

* 1 : FRONT FOG LIGHT SW

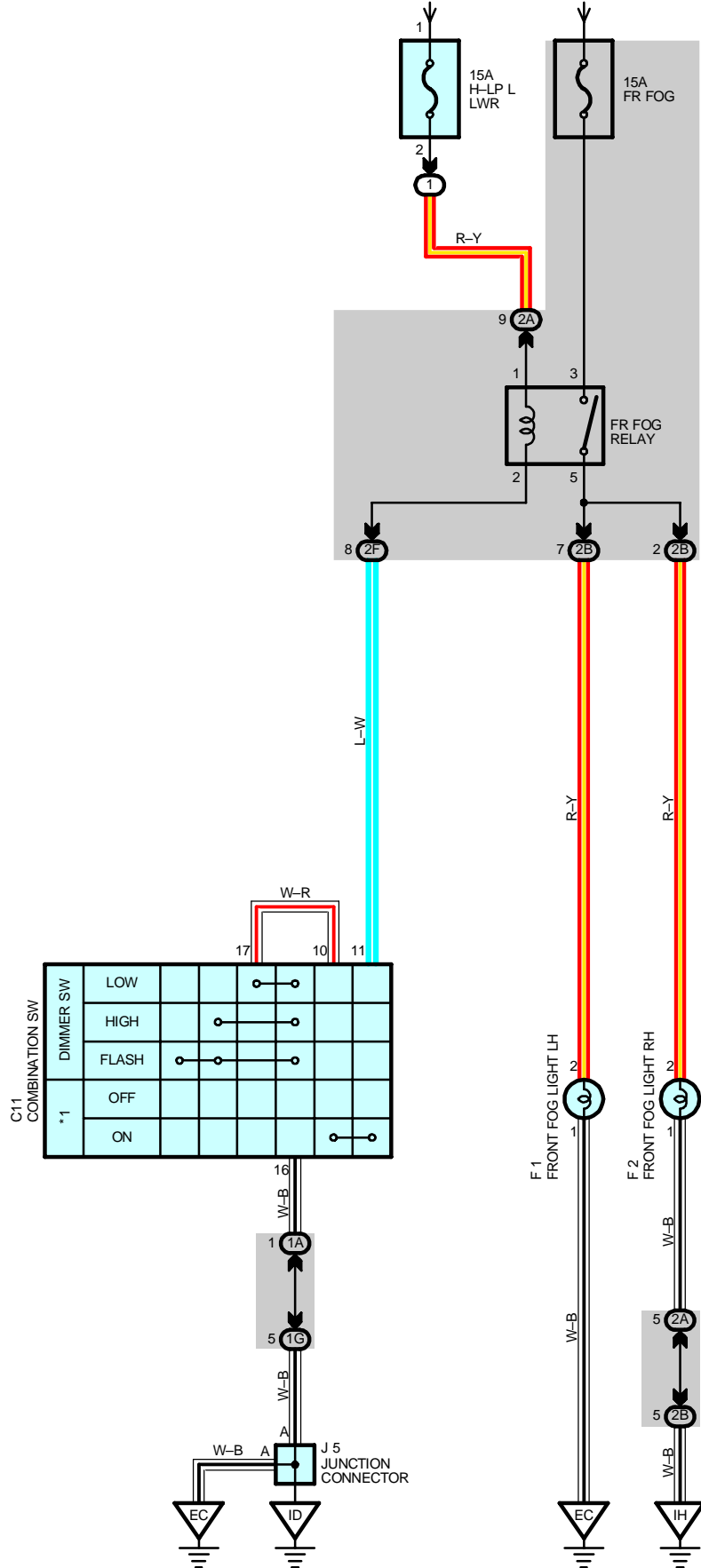

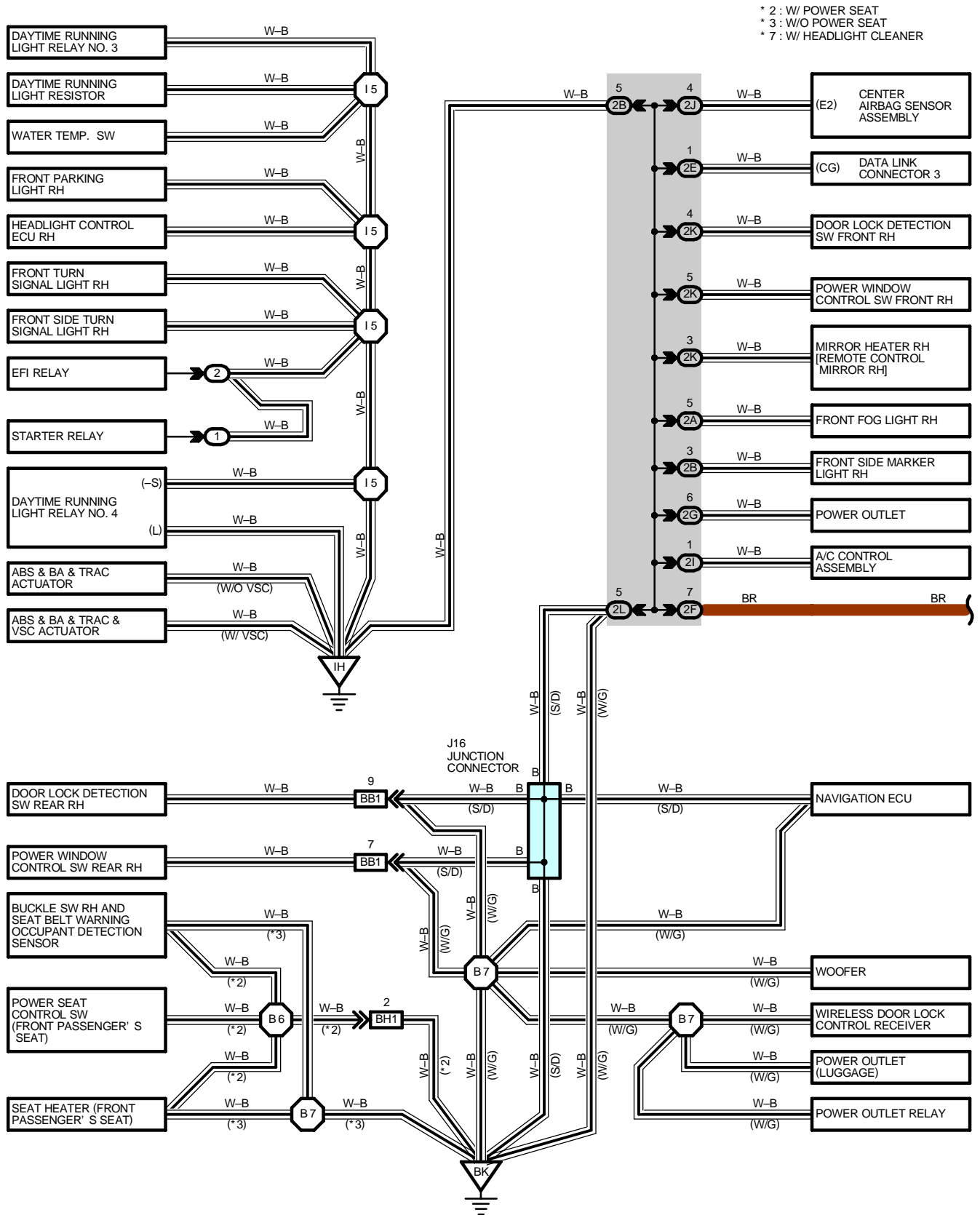

B HOW TO USE THIS MANUAL

[O] SYSTEM OUTLINE

Current is applied at all times through the STOP fuse to TERMINAL 2 of the stop light SW.
When the ignition SW is turned on, current flows from the GAUGE fuse to TERMINAL 8 of the light failure sensor, and also flows through the rear lights warning light to TERMINAL 4 of the light failure sensor.

STOP LIGHT DISCONNECTION WARNING

When the ignition SW is turned on and the brake pedal is pressed (Stop light SW on), if the stop light circuit is open, the current flowing from TERMINAL 7 of the light failure sensor to TERMINALS 1, 2 changes, so the light failure sensor detects the disconnection and the warning circuit of the light failure sensor is activated.

As a result, the current flows from TERMINAL 4 of the light failure sensor to TERMINAL 11 to GROUND and turns the rear lights warning light on. By pressing the brake pedal, the current flowing to TERMINAL 8 of the light failure sensor keeps the warning circuit on and holds the warning light on until the ignition SW is turned off.

[P] SERVICE HINTS

S6 STOP LIGHT SW

2-1 : Closed with the brake pedal depressed

L4 LIGHT FAILURE SENSOR

1, 2, 7-GROUND : Approx. 12 volts with the stop light SW on

4, 8-GROUND : Approx. 12 volts with the ignition SW at ON position

11-GROUND : Always continuity

[Q] ○ : PARTS LOCATION

Code	See Page	Code	See Page	Code	See Page
C7	34	L4	36	R7	37
H17	36	R6	37	S6	35

[R] ○ : RELAY BLOCKS

Code	See Page	Relay Blocks (Relay Block Location)
1	18	R/B No.1 (Instrument Panel Left)

[S] ○ : JUNCTION BLOCK AND WIRE HARNESS CONNECTOR

Code	See Page	Junction Block and Wire Harness (Connector Location)
IB	20	Instrument Panel Wire and Instrument Panel J/B (Lower Finish Panel)
3C	22	Instrument Panel Wire and J/B No.3 (Instrument Panel Left Side)

[T] □ : CONNECTOR JOINING WIRE HARNESS AND WIRE HARNESS

Code	See Page	Joining Wire Harness and Wire Harness (Connector Location)
IE1	42	Floor Wire and Instrument Panel Wire (Left Kick Panel)
BV1	50	Luggage Room Wire and Floor Wire (Luggage Compartment Left)

[U] ▽ : GROUND POINTS

Code	See Page	Ground Points Location
BL	50	Under the Left Quarter Pillar
BO	50	Back Panel Center

[V] ○ : SPLICE POINTS

Code	See Page	Wire Harness with Splice Points	Code	See Page	Wire Harness with Splice Points
I5	44	Cowl Wire	B18	50	Luggage Room Wire

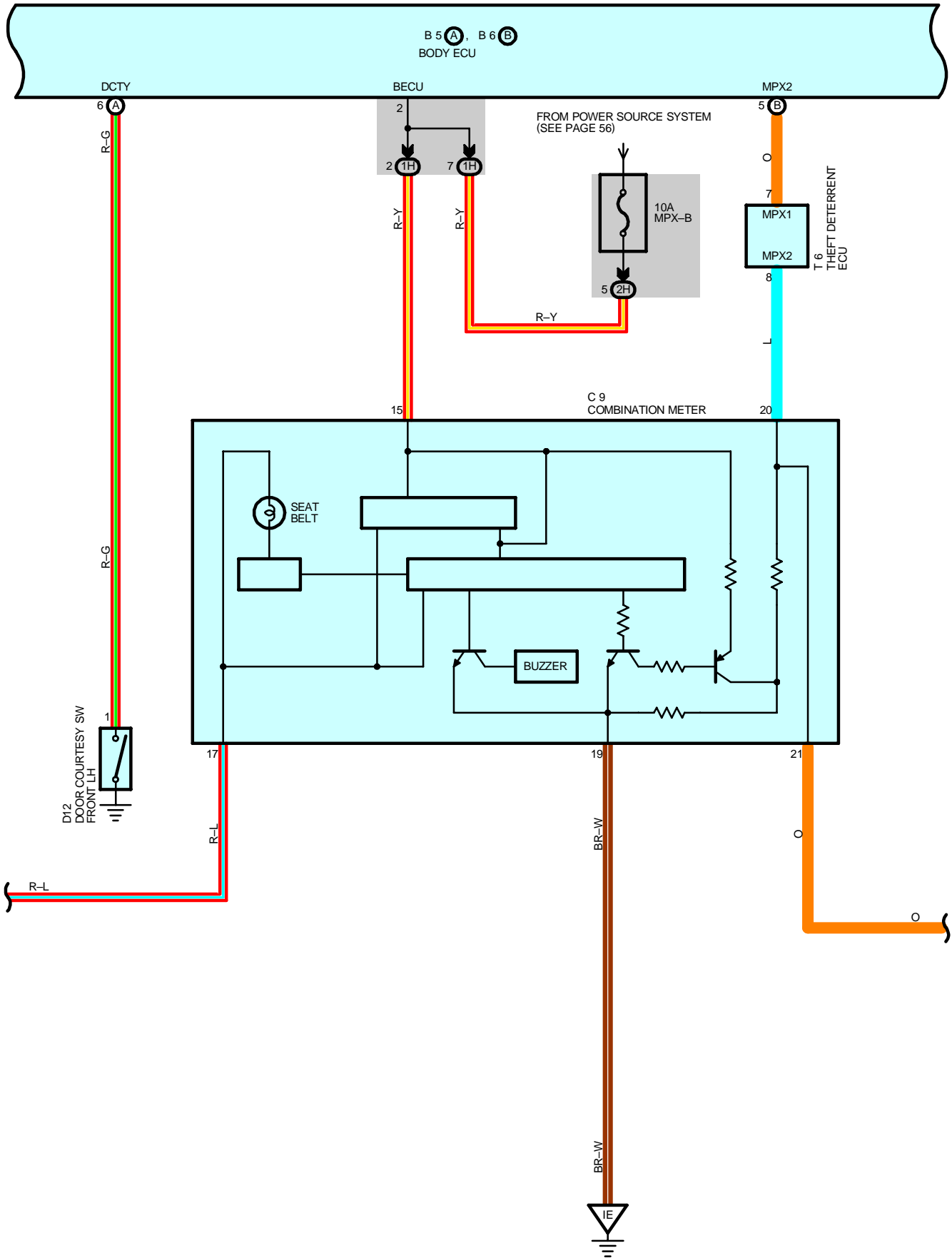

M 4 (A), M 5 (B)
MULTI-DISPLAY

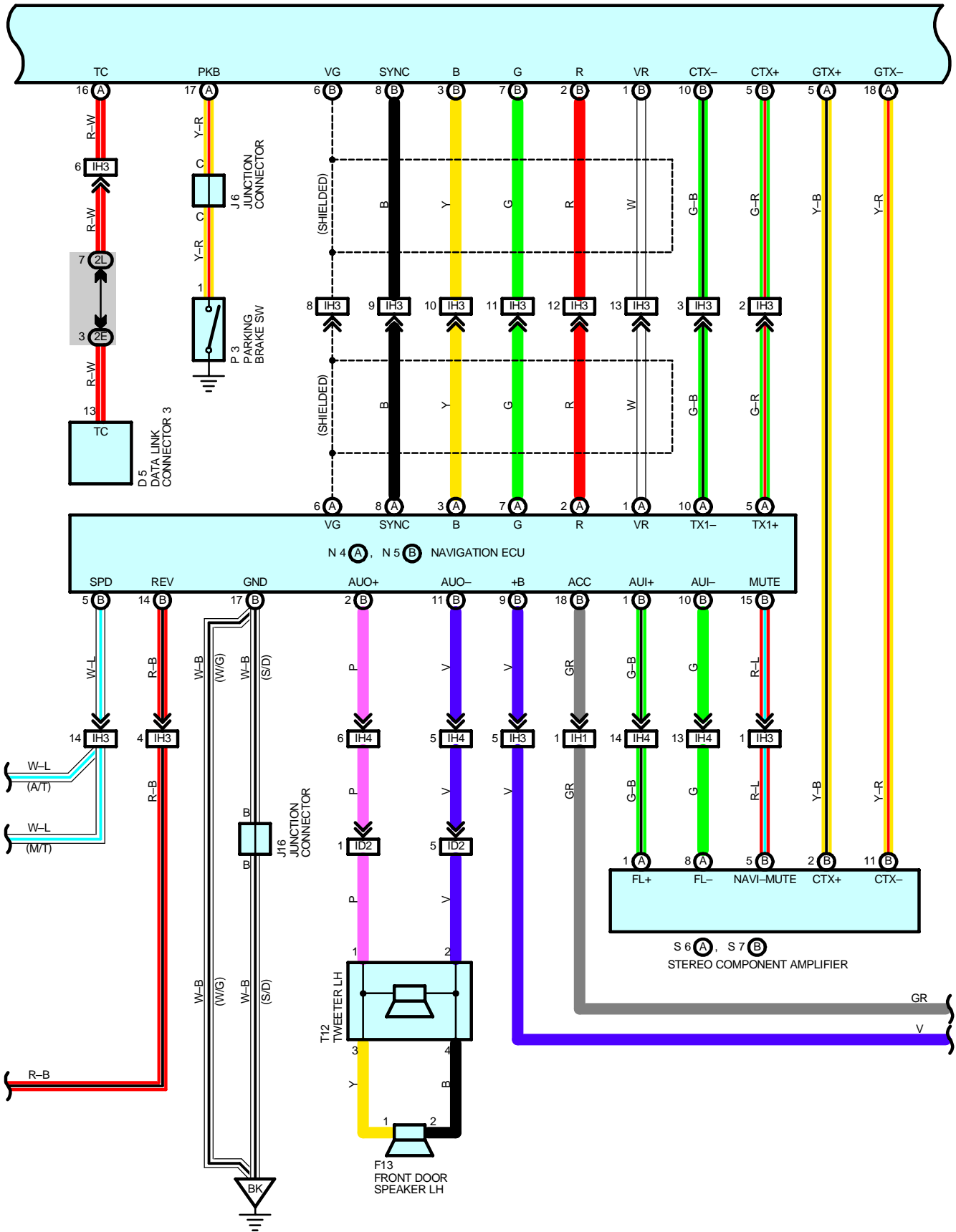

1 IS 300 ELECTRICAL WIRING DIAGRAM

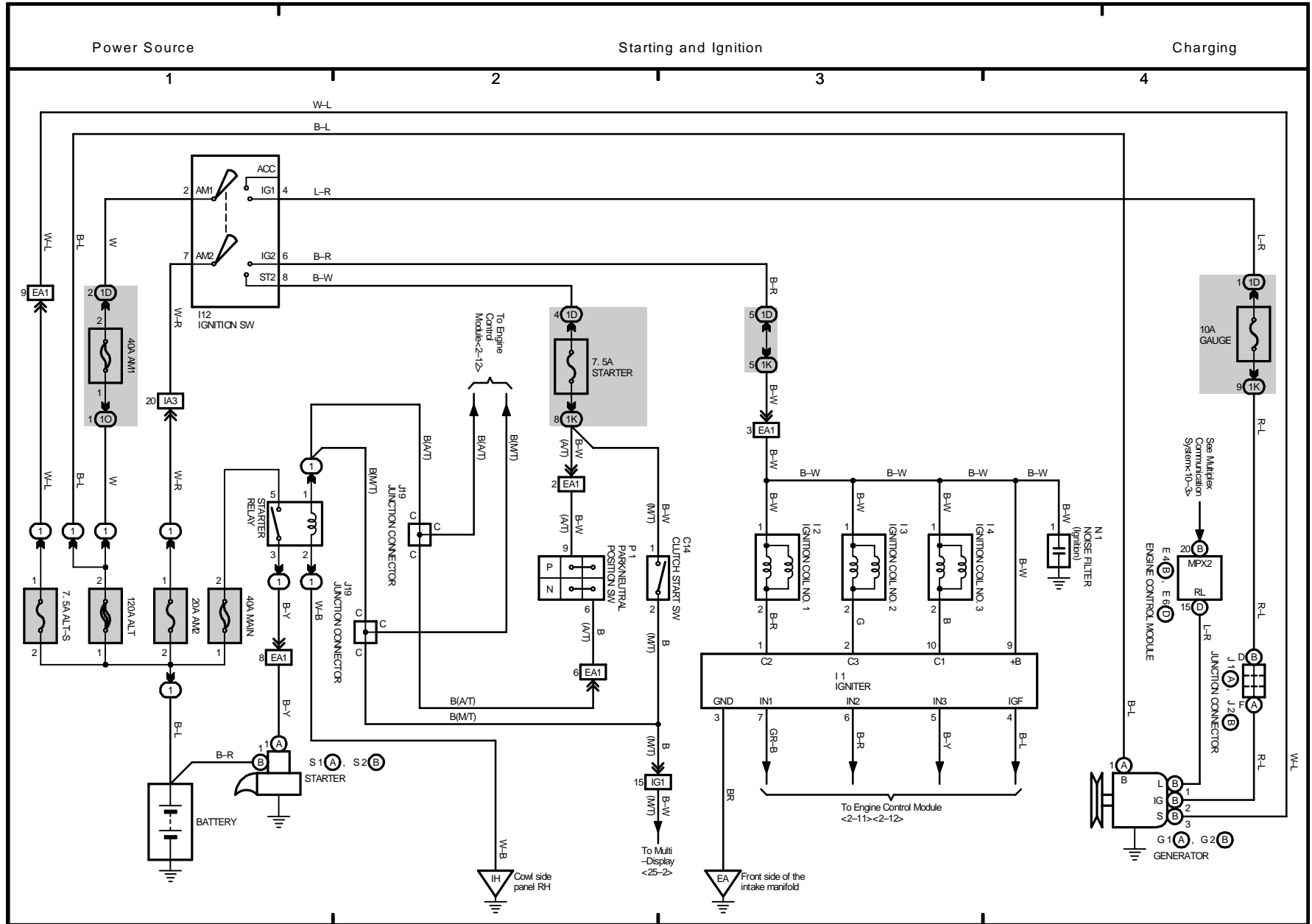

2002 LEXUS IS 300 (EWD451U)

M OVERALL ELECTRICAL WIRING DIAGRAM

13 IS 300

