

AIR CONDITIONING

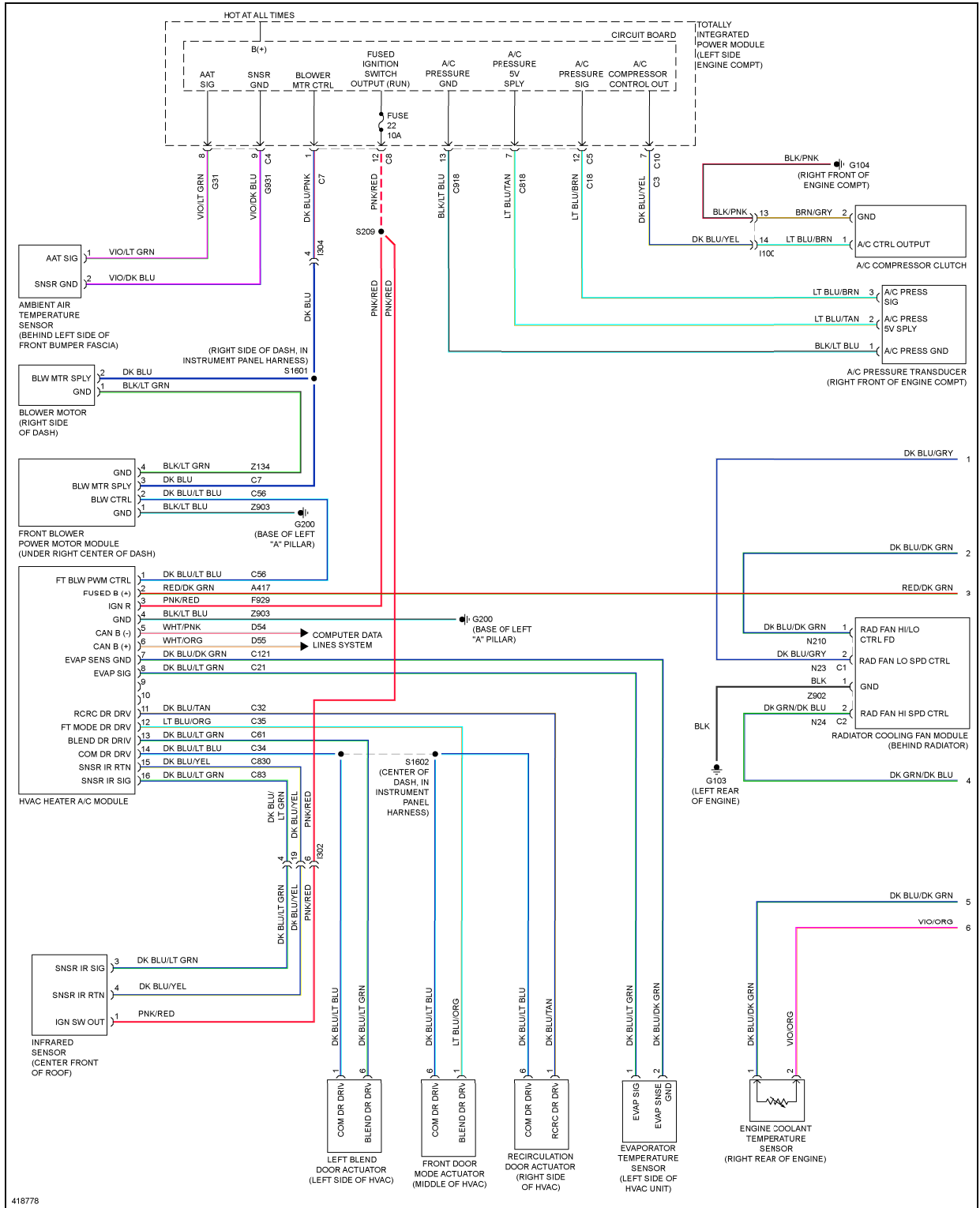

Fig. 1: Automatic A/C Circuit (1 of 2)

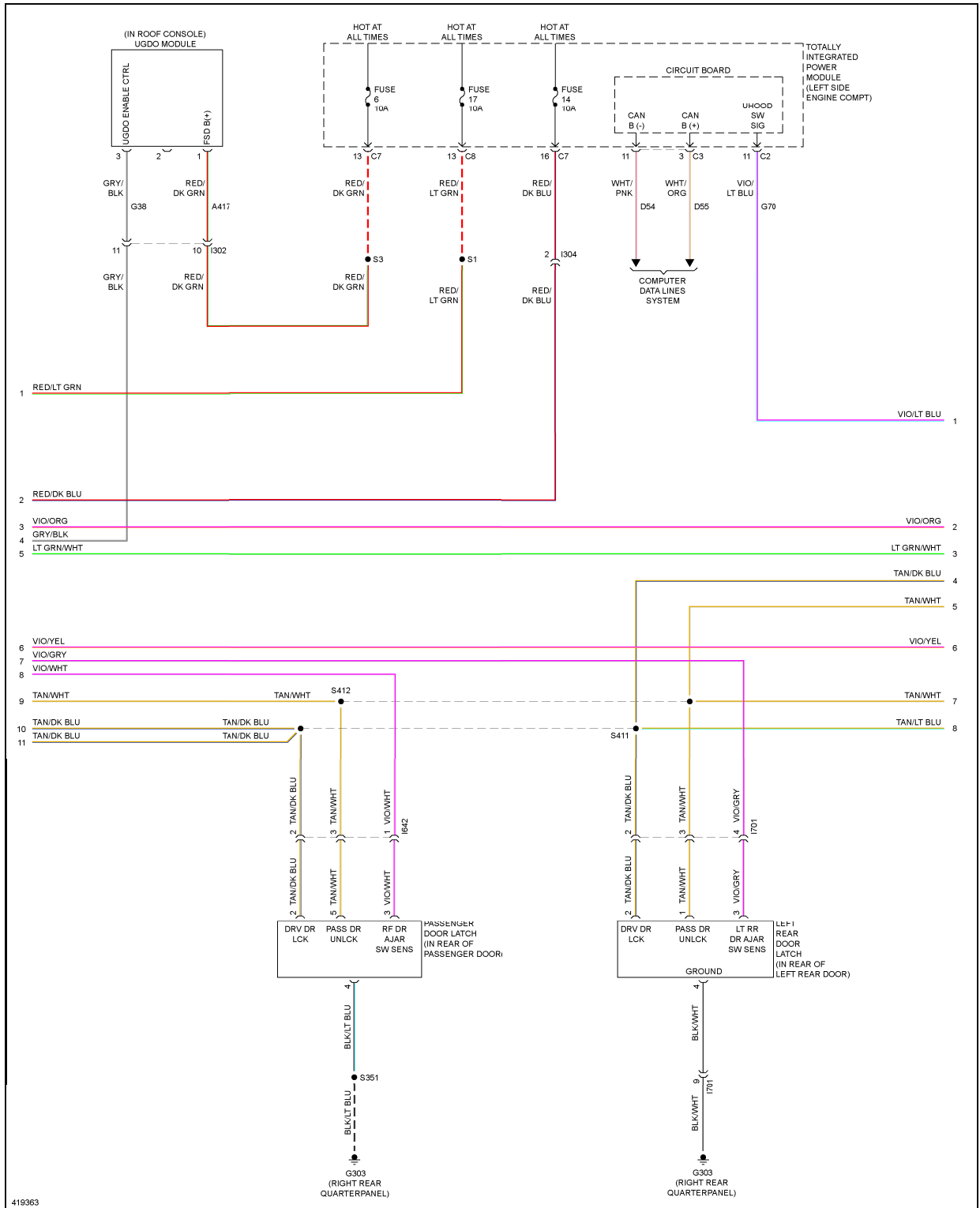

Fig. 5: Anti-theft Circuit (2 of 3)

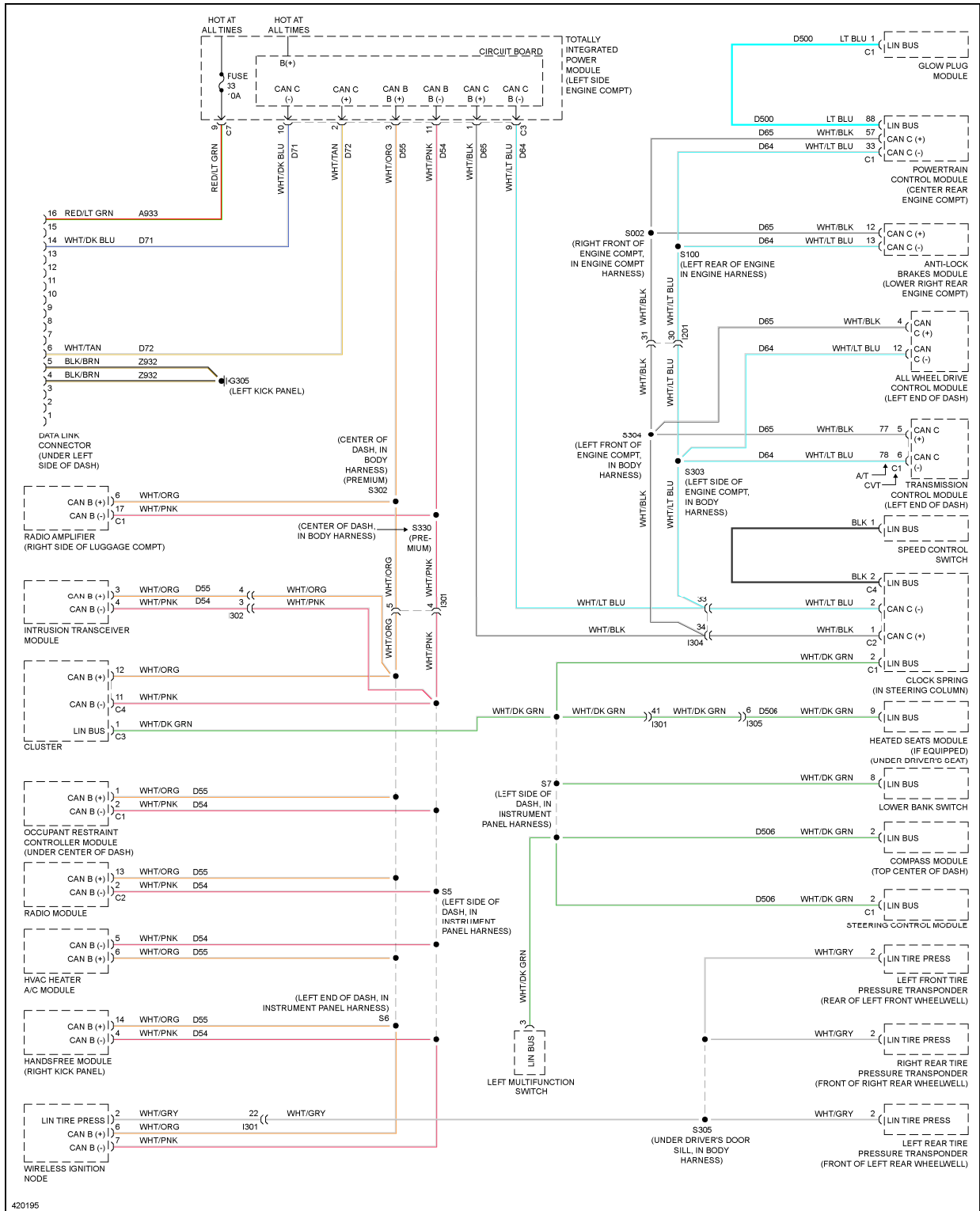
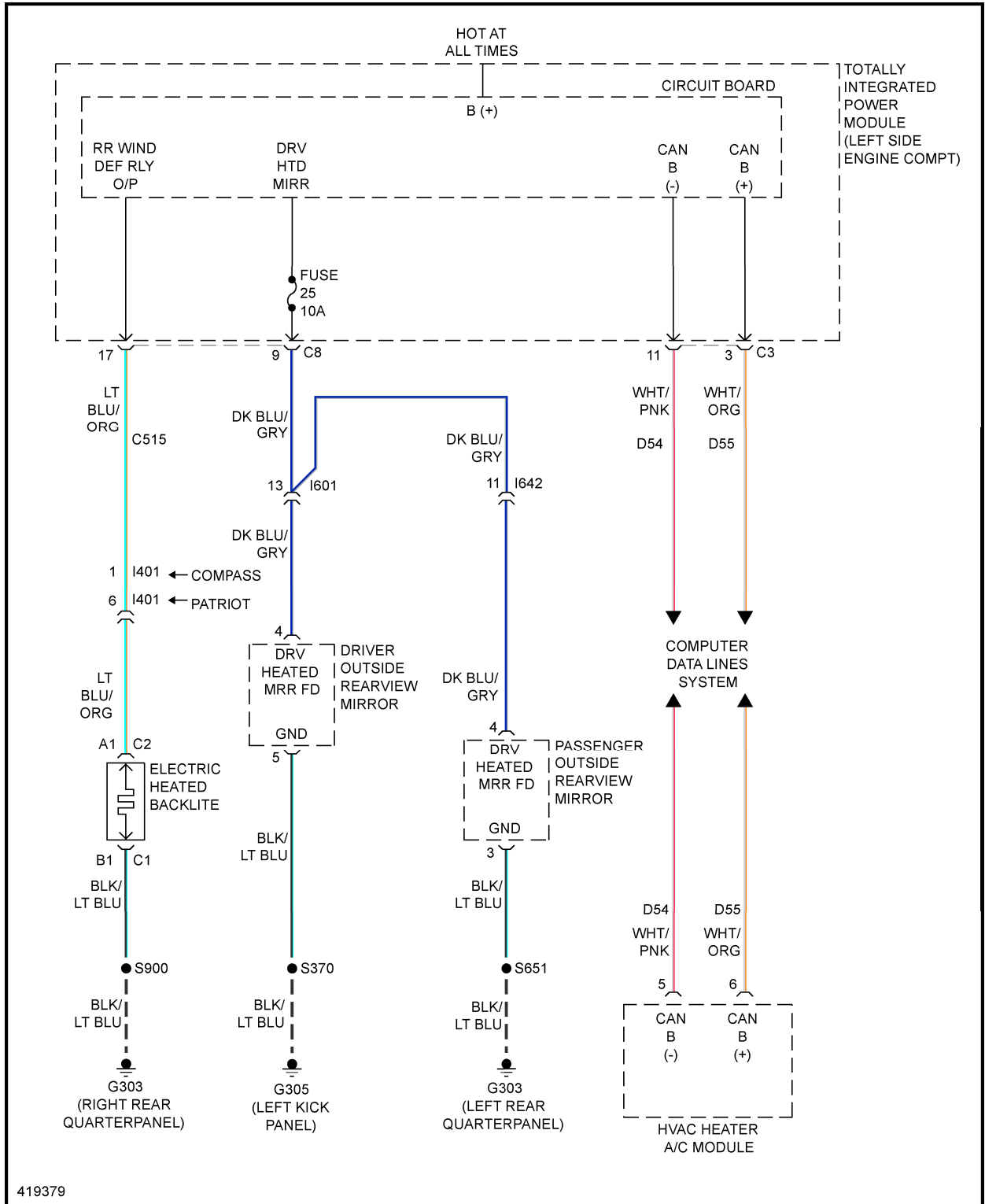

Fig. 8: Computer Data Lines Circuit

COOLING FAN



**Fig. 12: Defoggers Circuit**

**ENGINE PERFORMANCE**

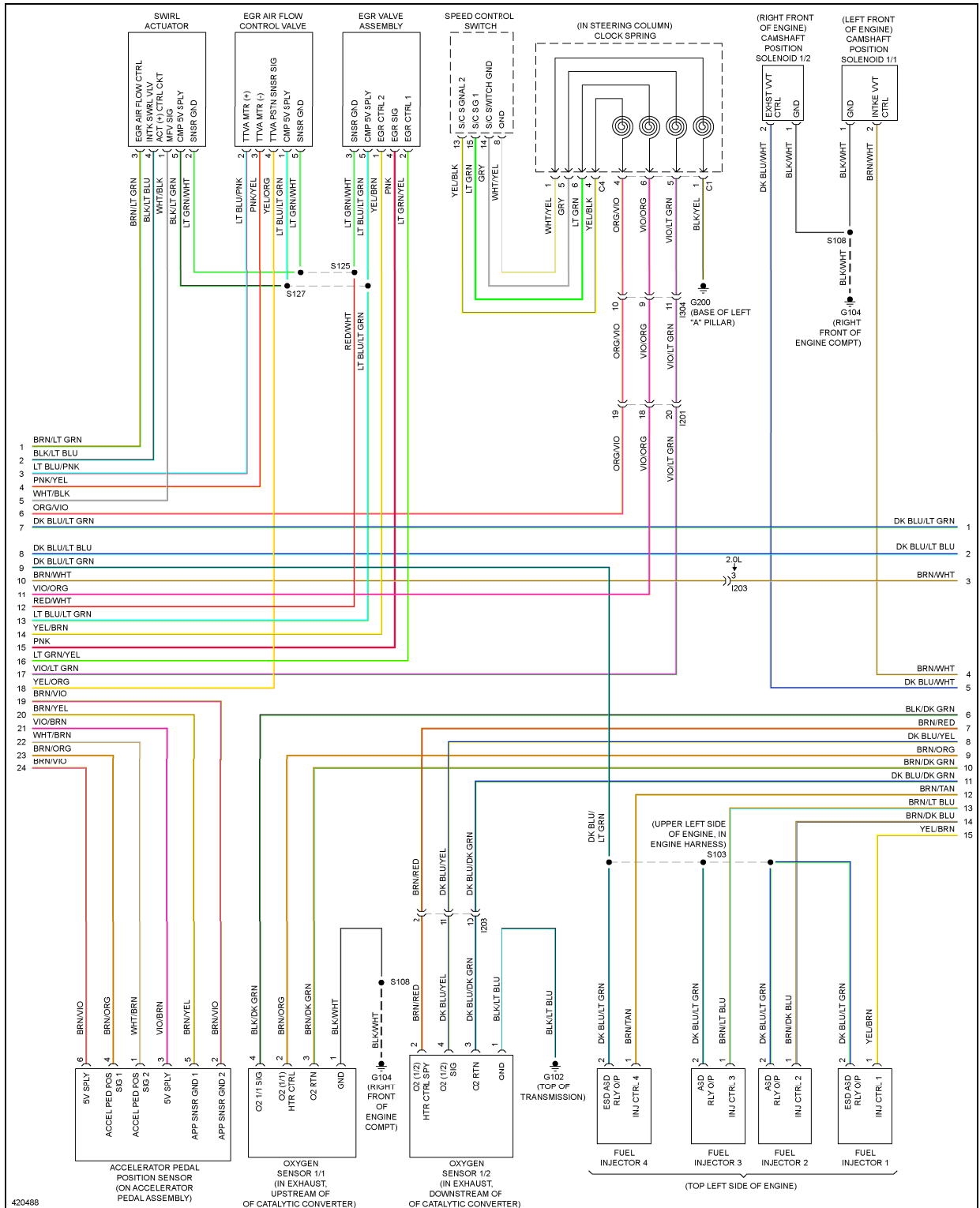
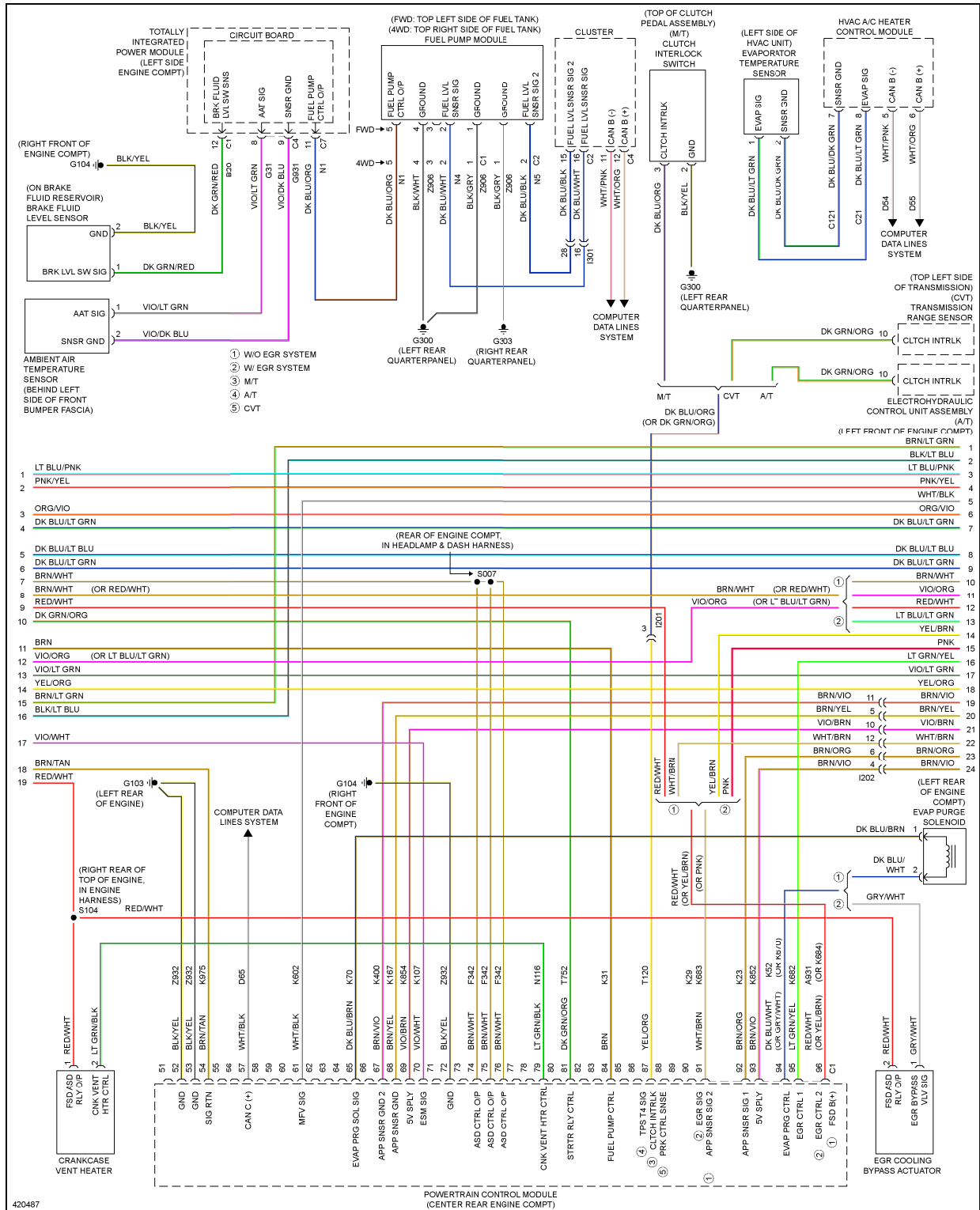

Fig. 15: 2.0L, Engine Performance Circuit (3 of 5)

# 2014 Jeep Patriot Limited

## 2014 SYSTEM WIRING DIAGRAMS Jeep - Patriot



**Fig. 19: 2.4L, Engine Performance Circuit (2 of 5)**

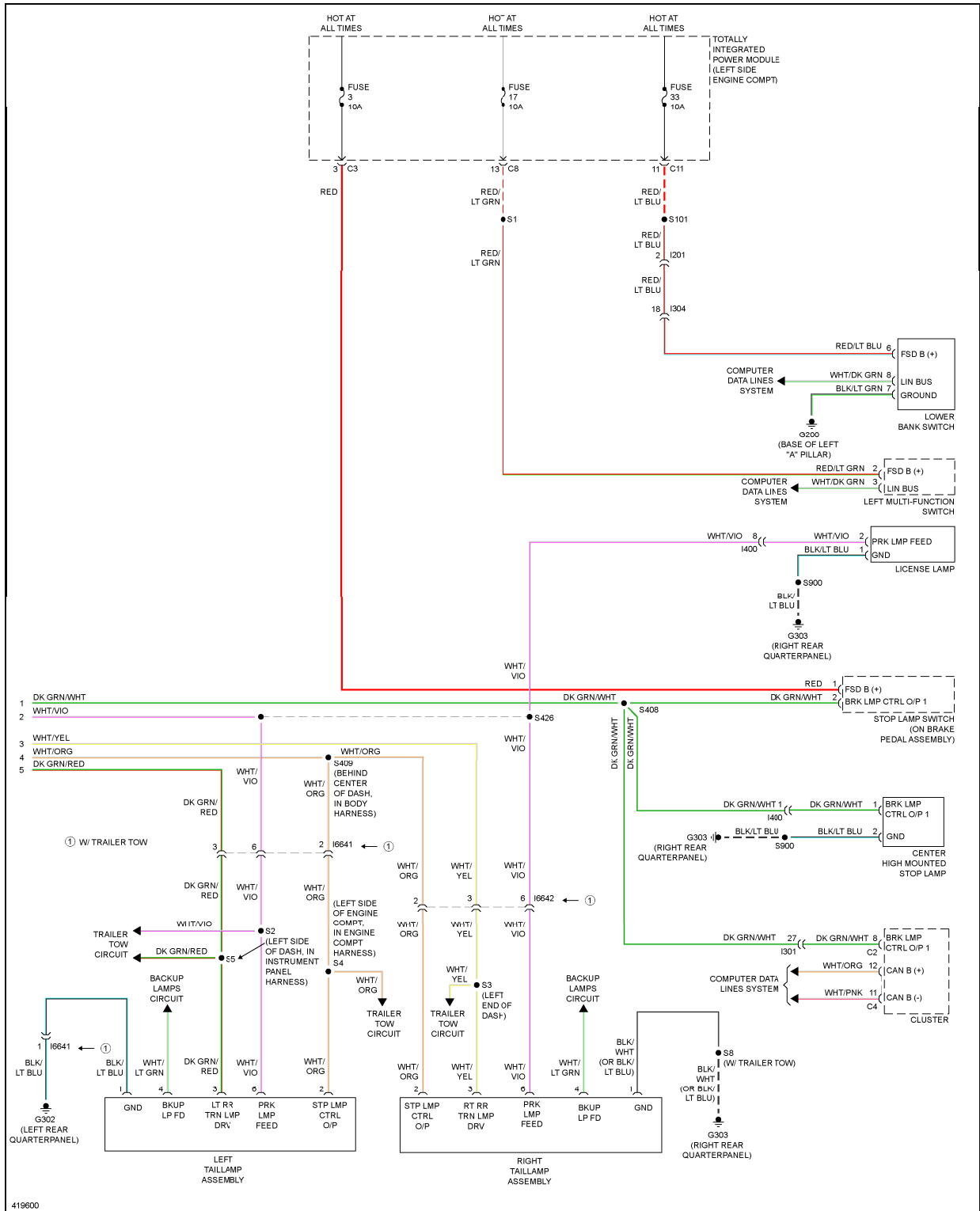
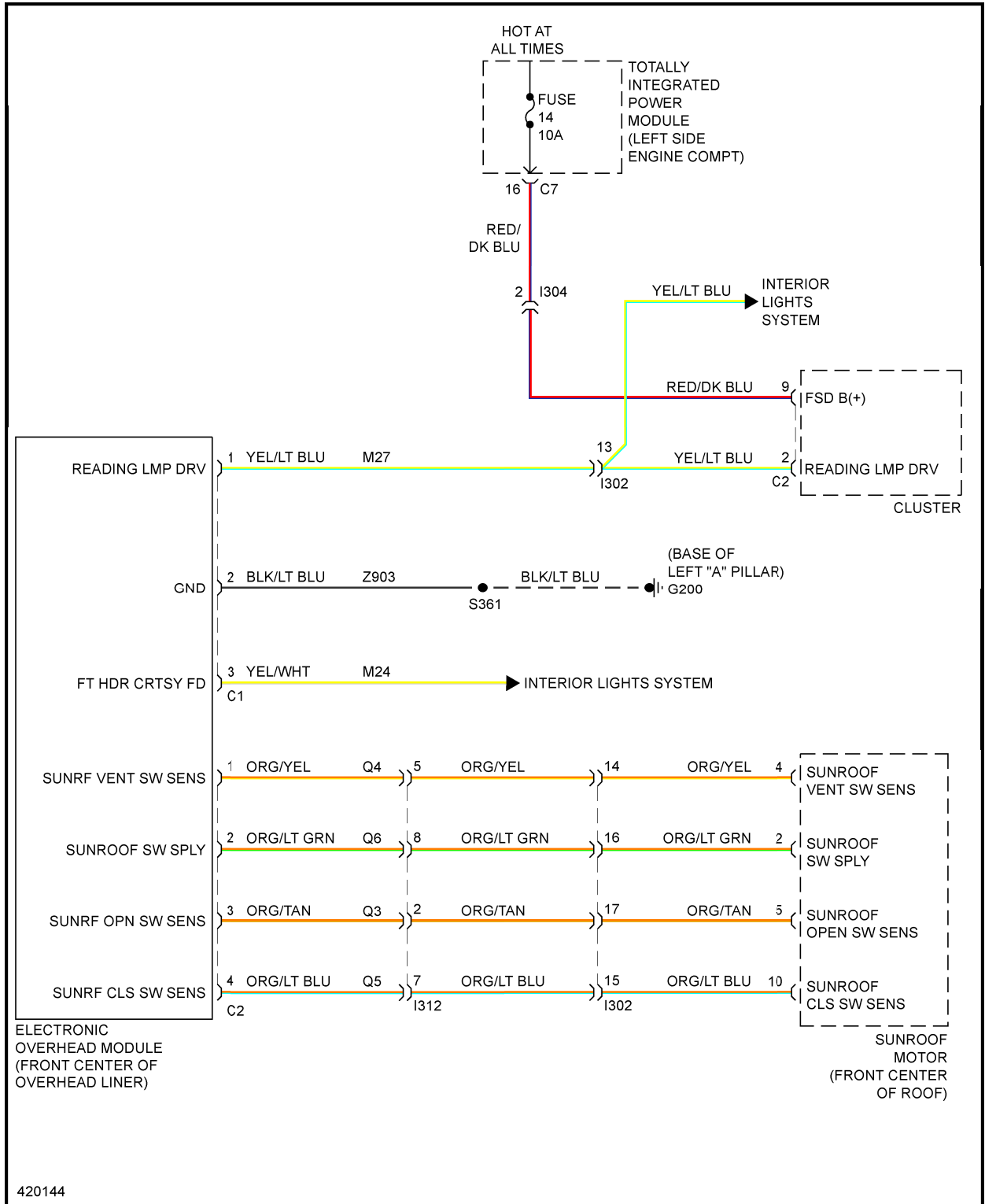

Fig. 25: Exterior Lamps Circuit (2 of 2)



**Fig. 33: Overhead Console Circuit**

**INTERIOR LIGHTS**



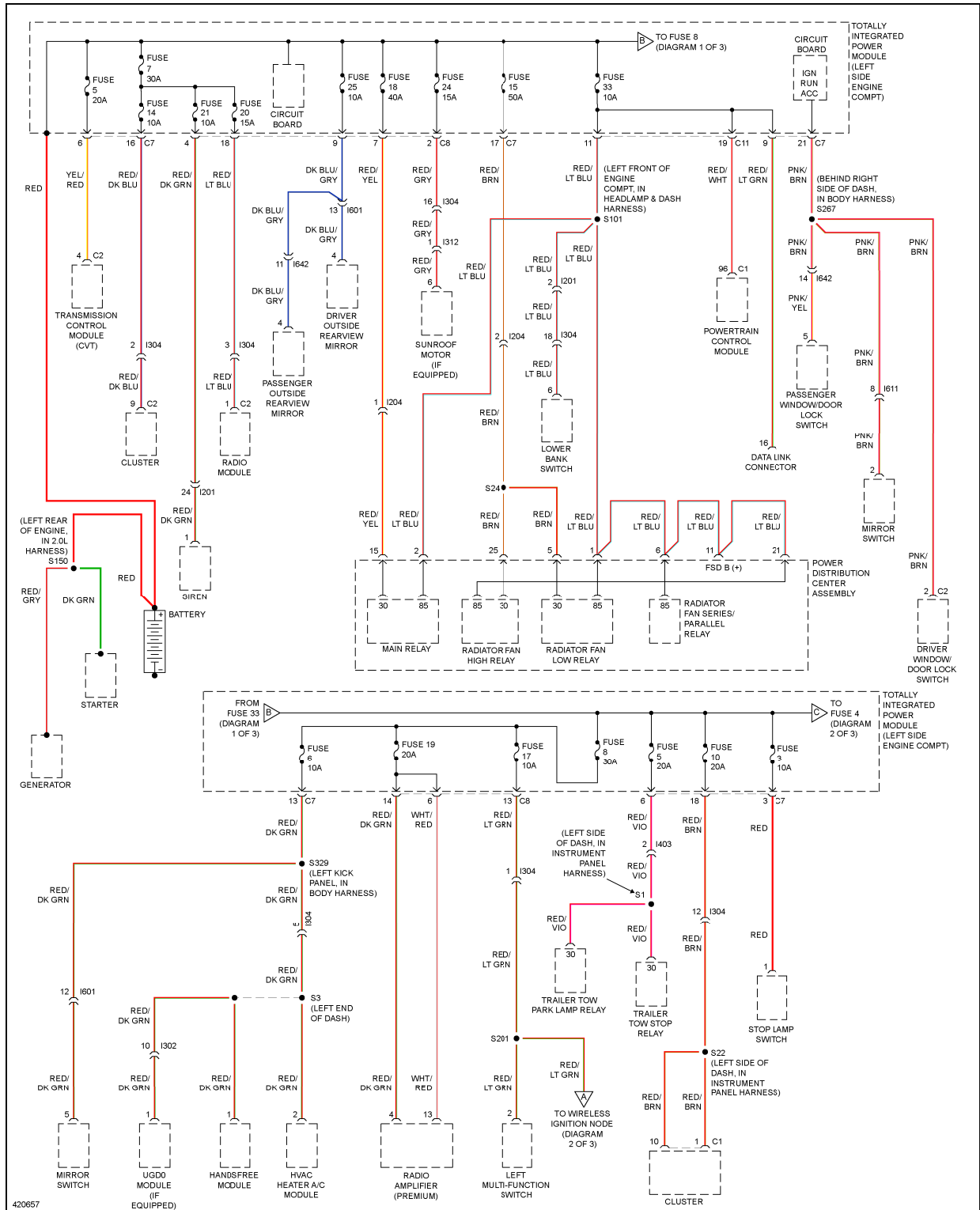
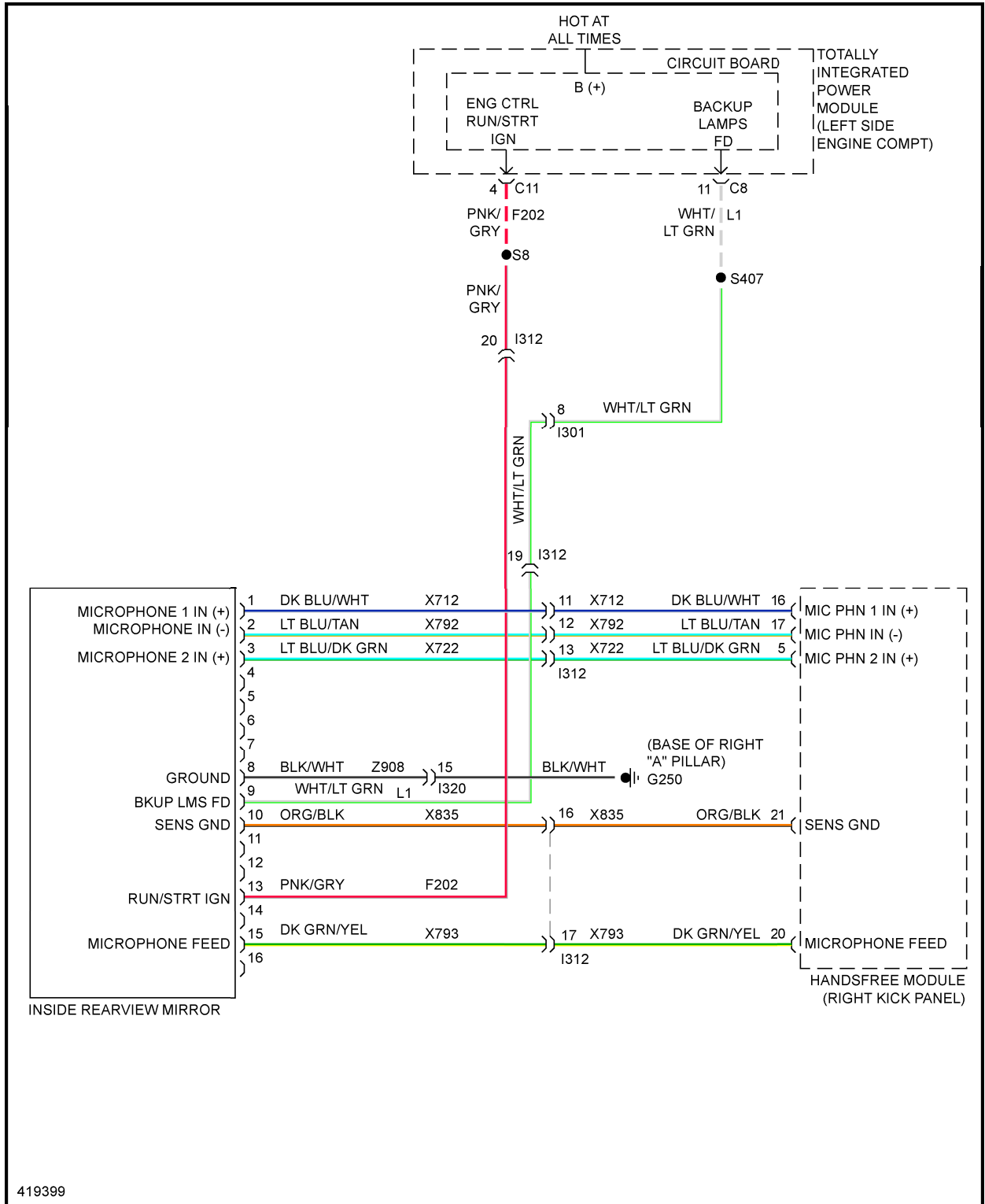

Fig. 39: Power Distribution Circuit (1 of 3)



**Fig. 45: Automatic Day/Night Mirror Circuit**

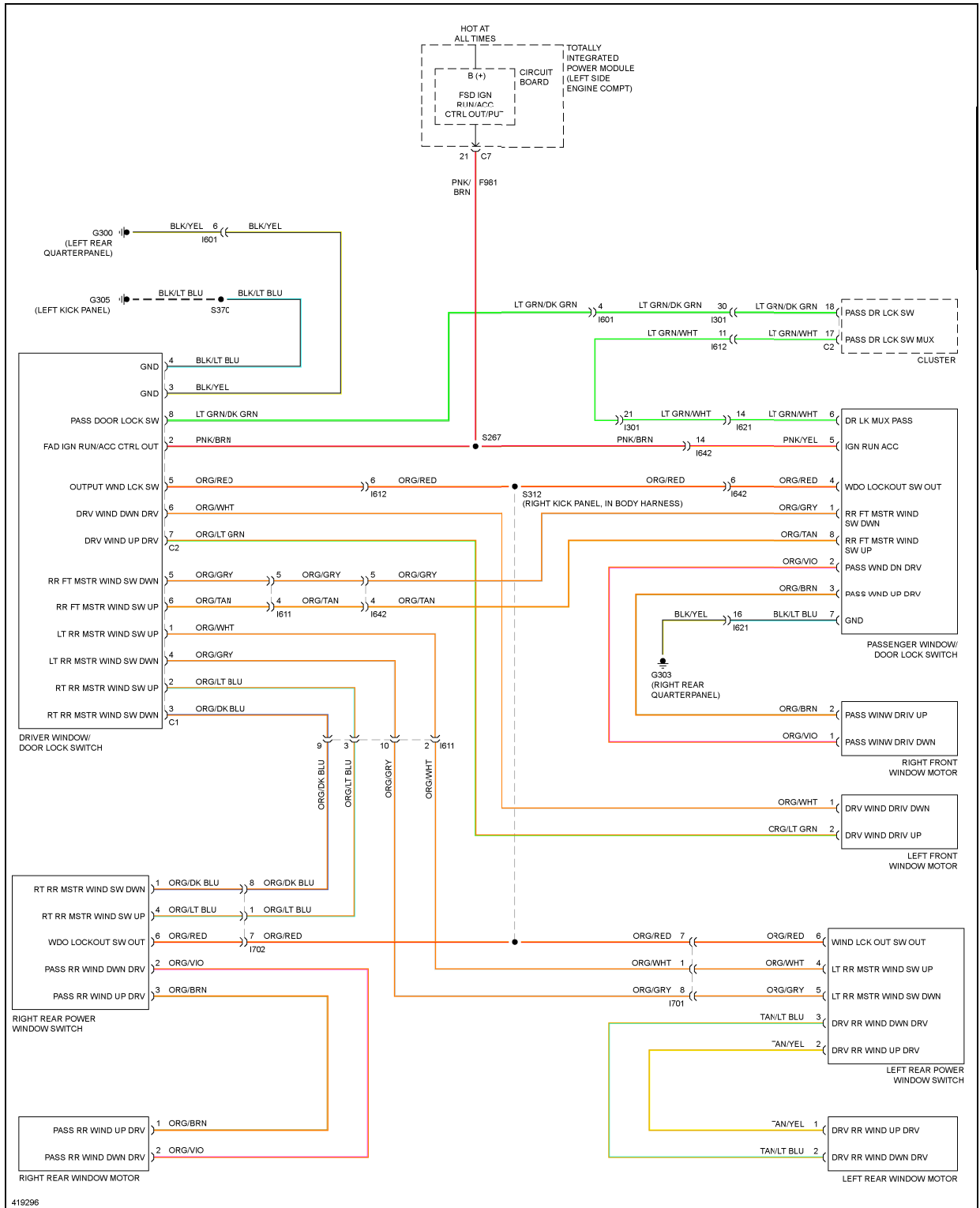
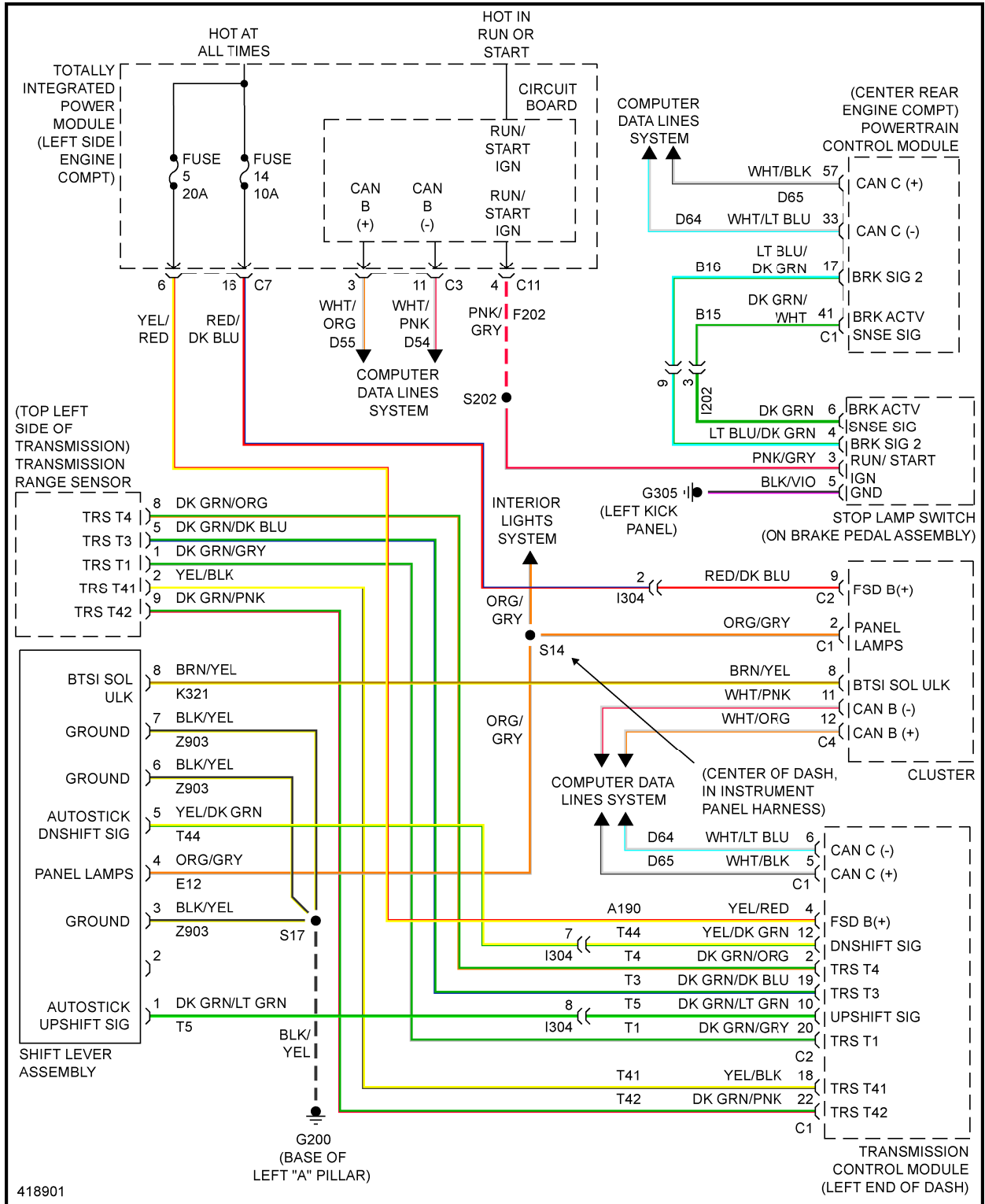

Fig. 50: Power Windows Circuit

RADIO

# 2014 Jeep Patriot Limited

## 2014 SYSTEM WIRING DIAGRAMS Jeep - Patriot



**Fig. 57: Shift Interlock Circuit, CVT W/ Autostick**

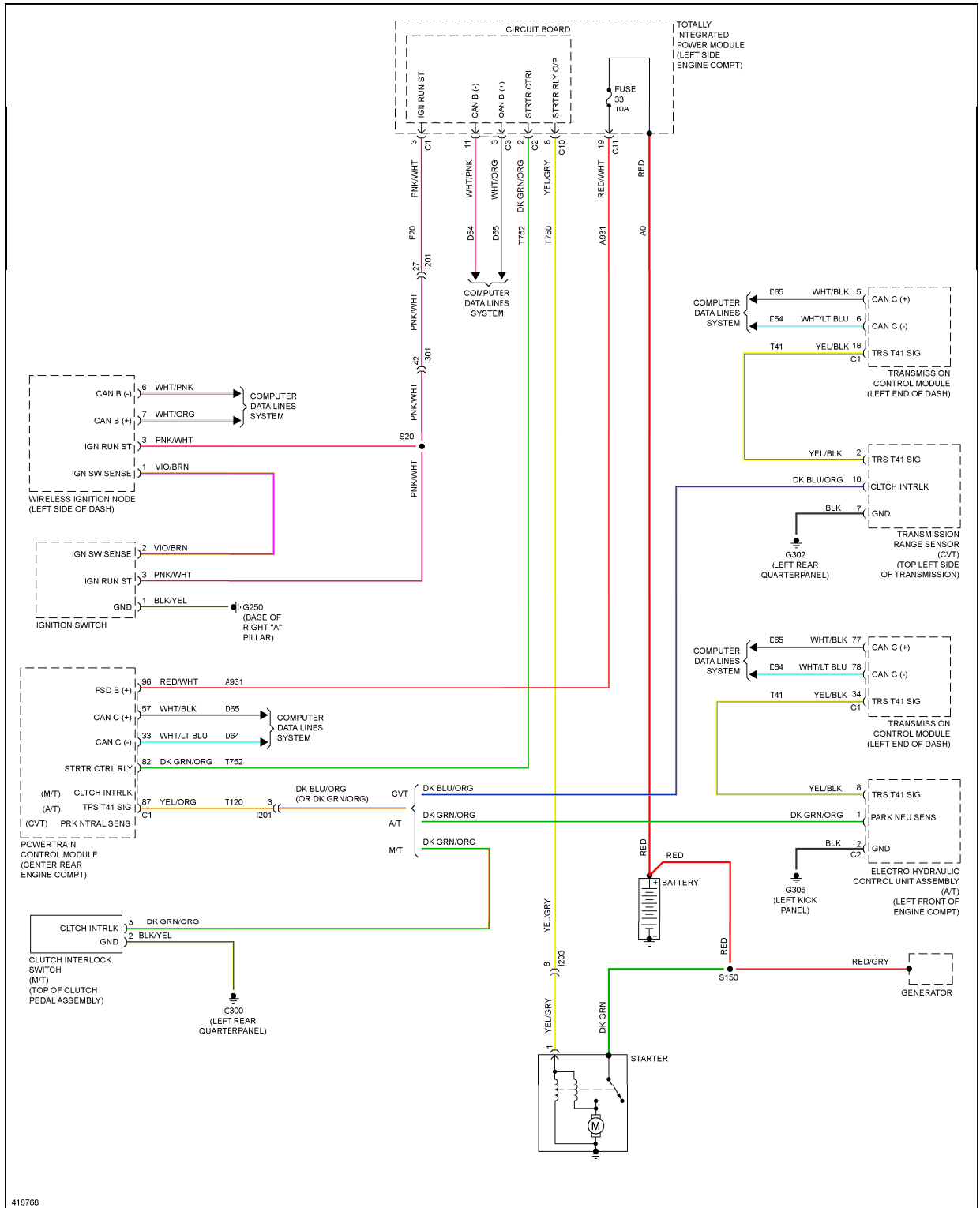
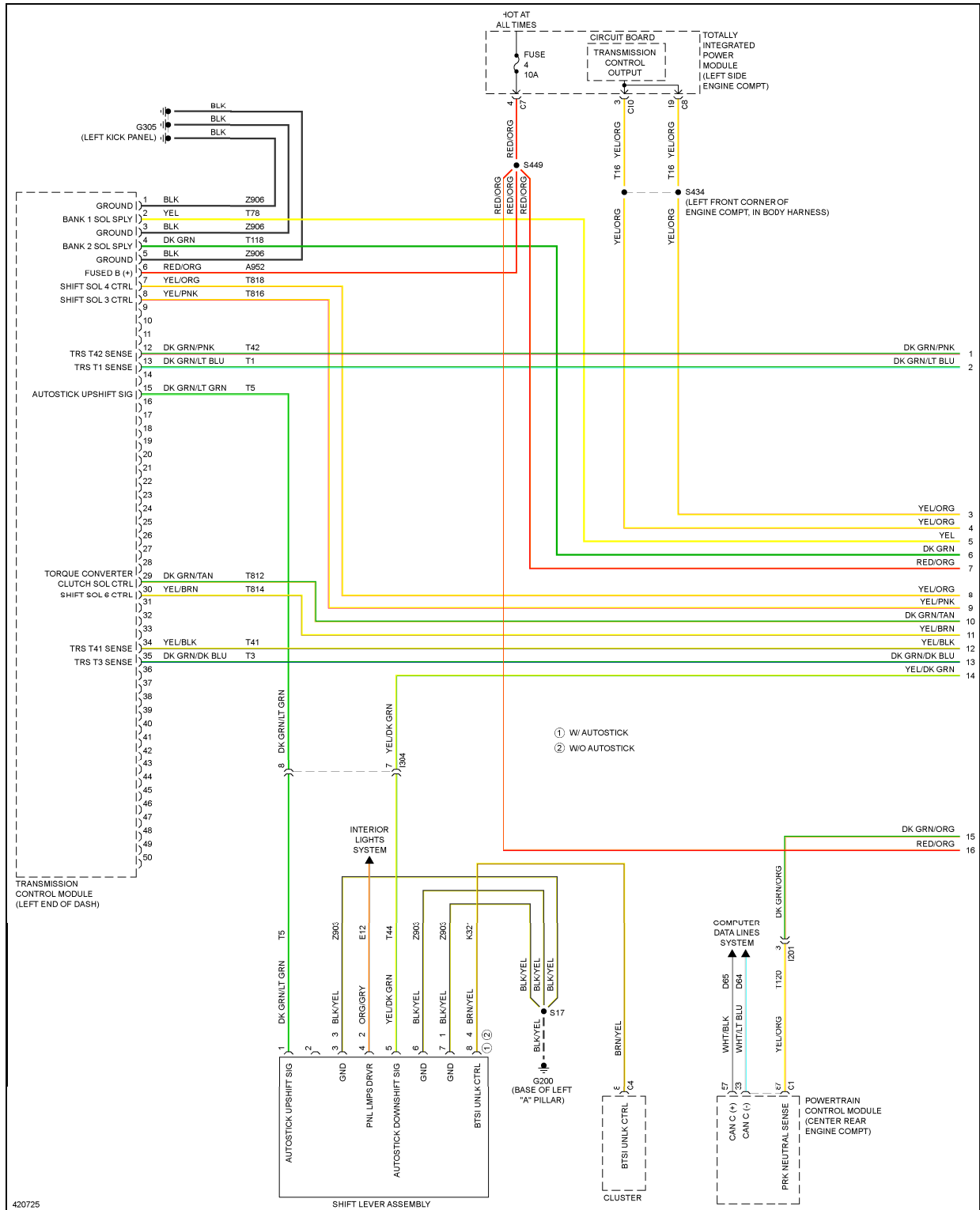

Fig. 60: Starting Circuit

SUPPLEMENTAL RESTRAINTS

# 2014 Jeep Patriot Limited

## 2014 SYSTEM WIRING DIAGRAMS Jeep - Patriot



**Fig. 64: A/T Circuit, 6 Speed (1 of 2)**

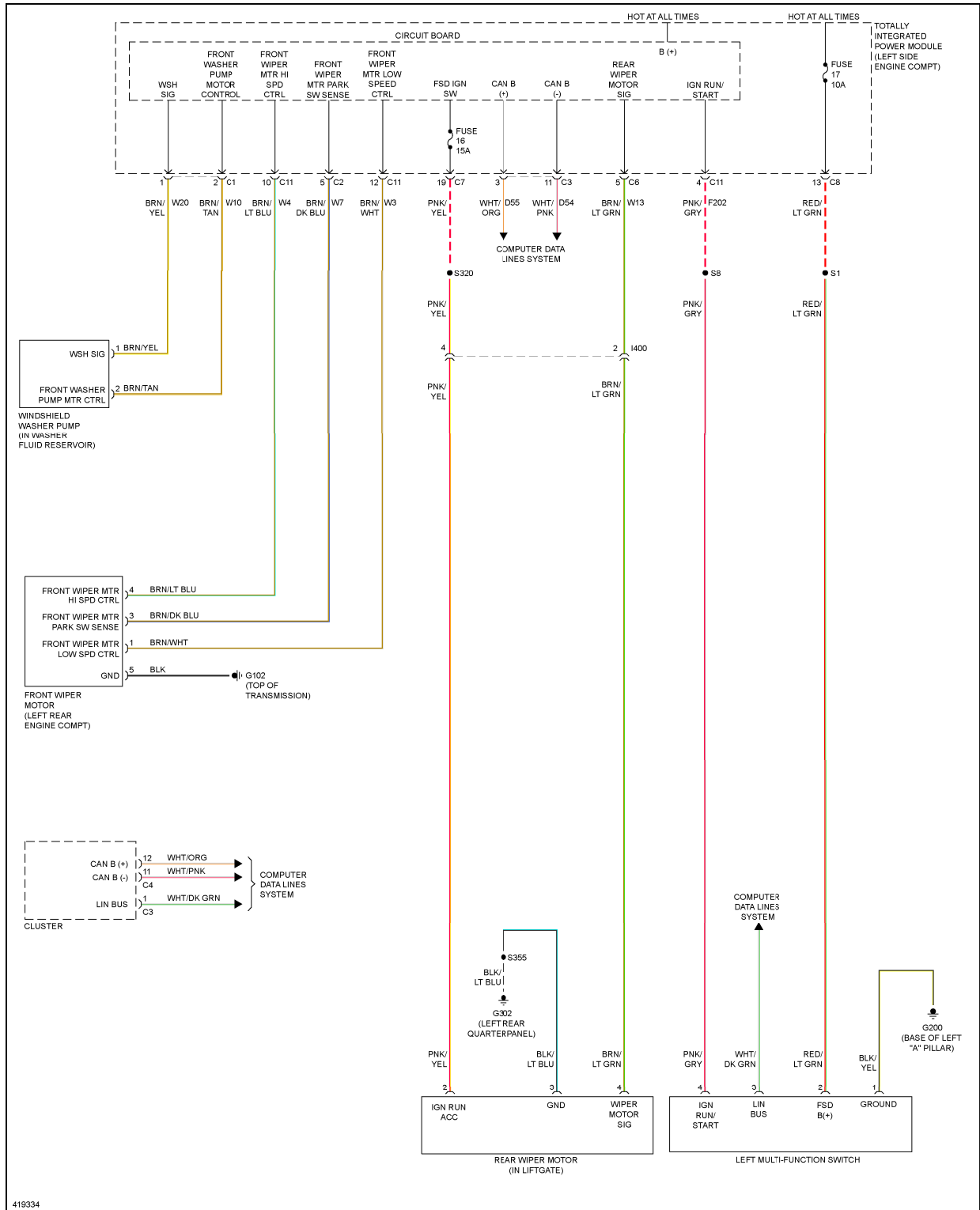

Fig. 69: Wiper/Washer Circuit