

**AIR CONDITIONING**

Fig 1: Automatic A/C Circuit (1 of 4)

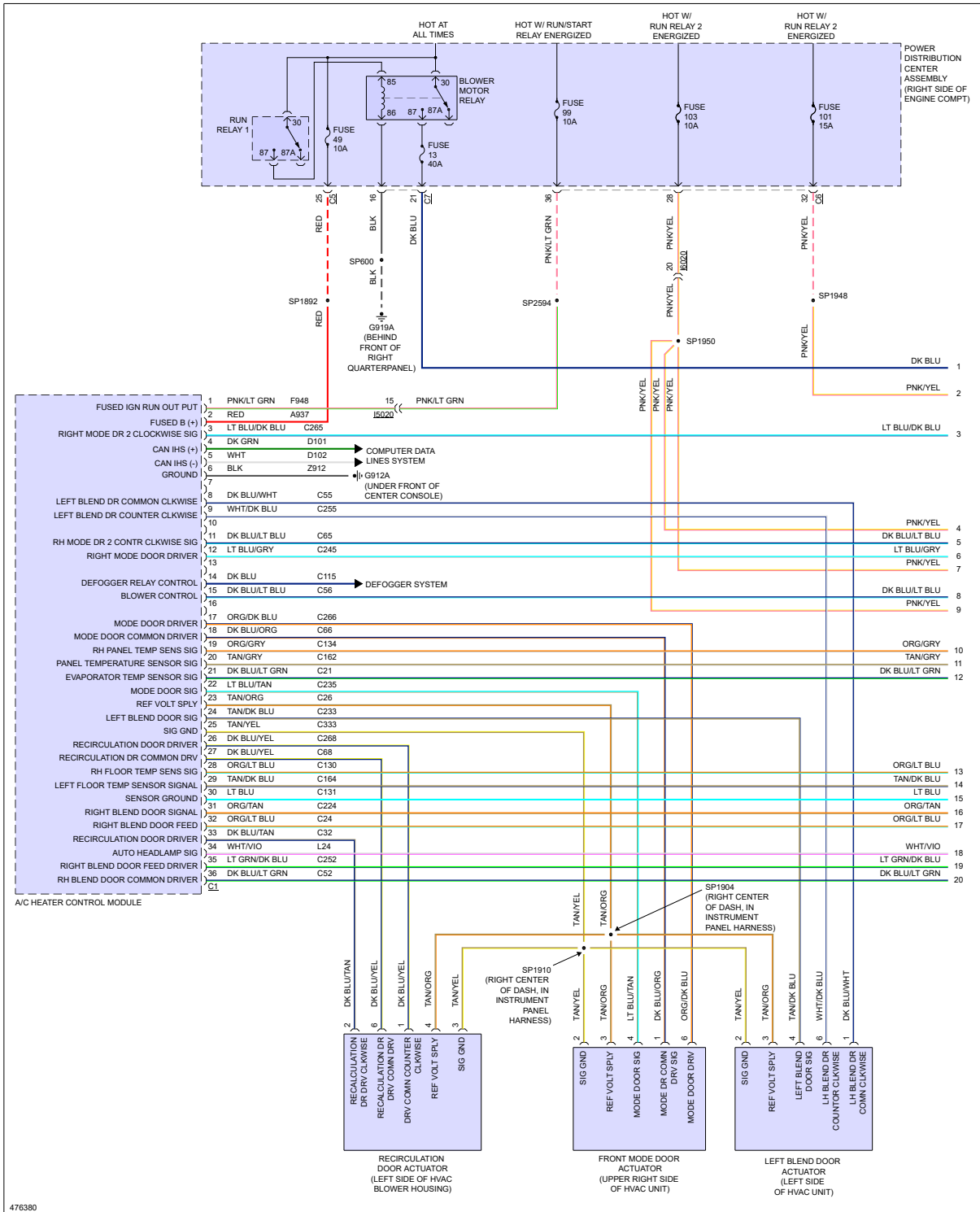

Fig 4: Automatic A/C Circuit (4 of 4)

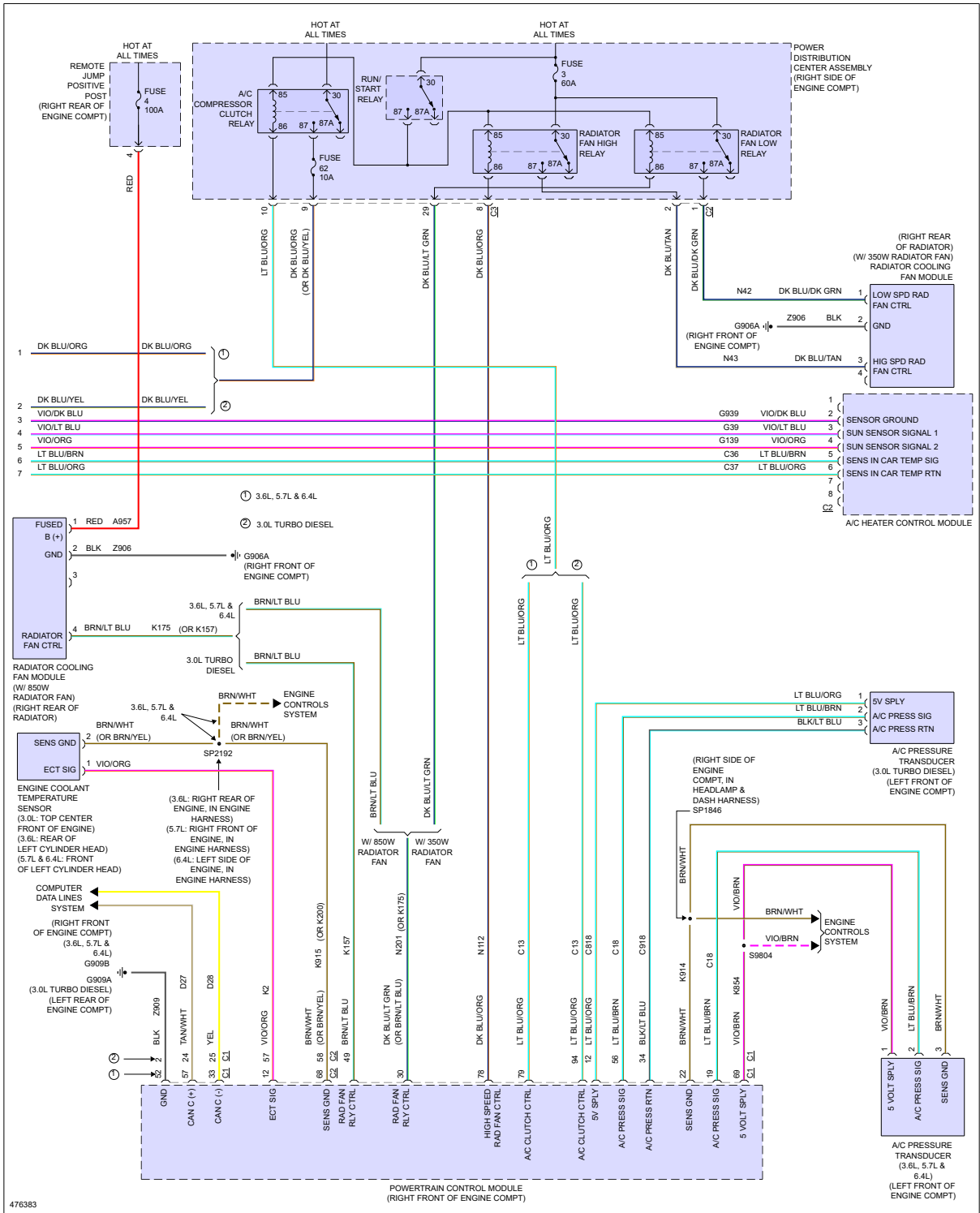
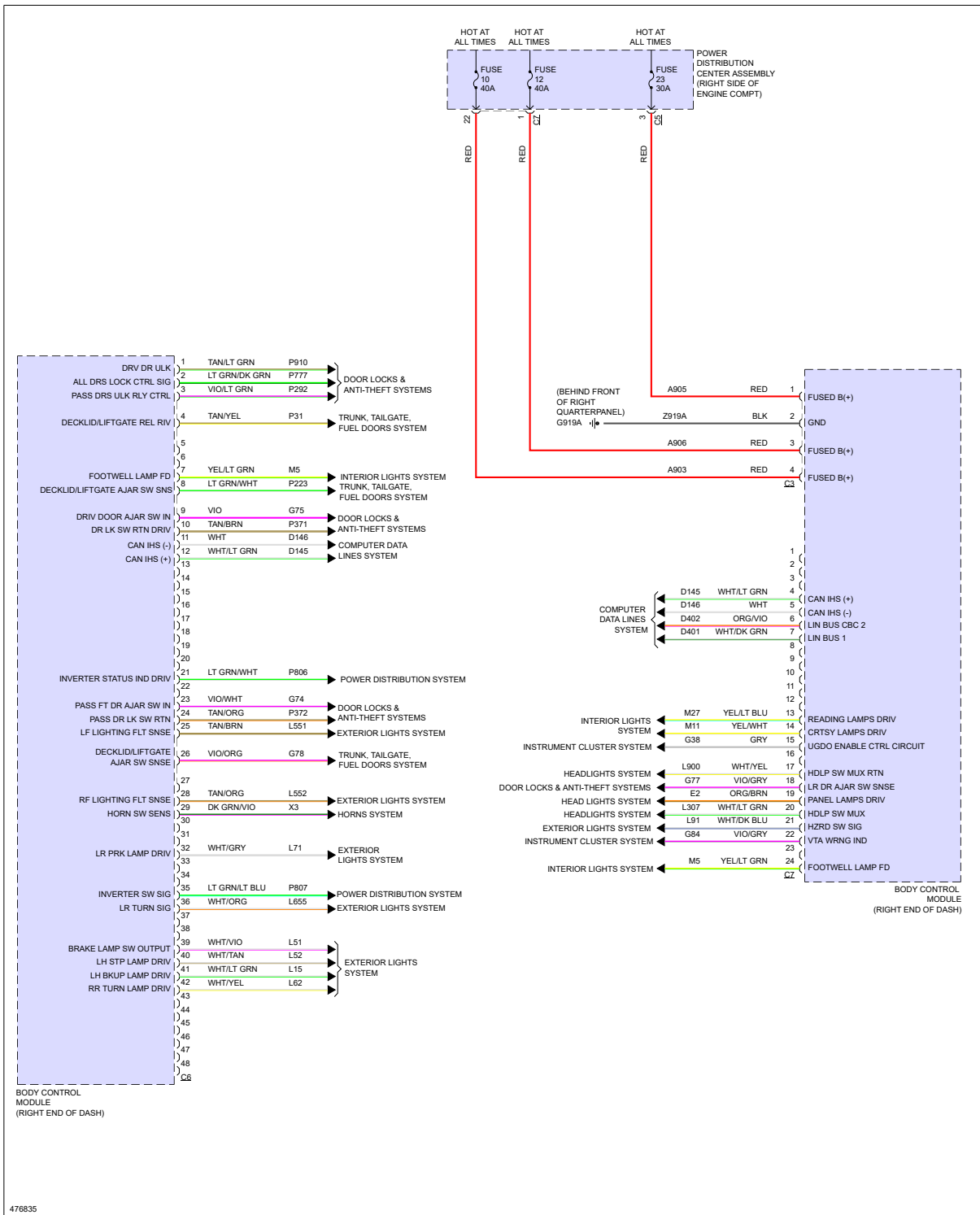

Fig 2: Body Control Modules Circuit (2 of 2)



# DEFOGGERS

Fig 1: Defoggers Circuit

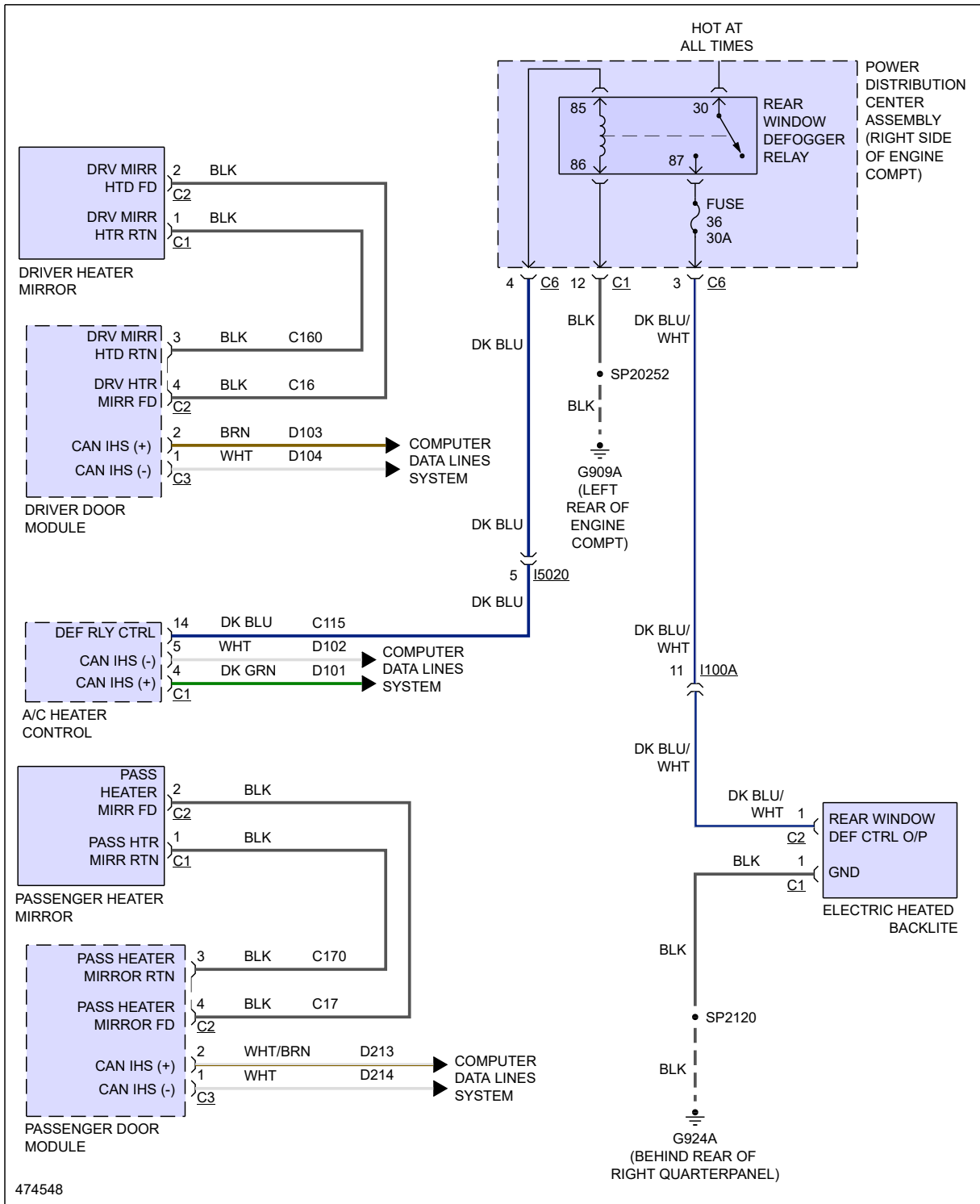

Fig 7: 3.0L Turbo Diesel, Engine Performance Circuit (7 of 8)

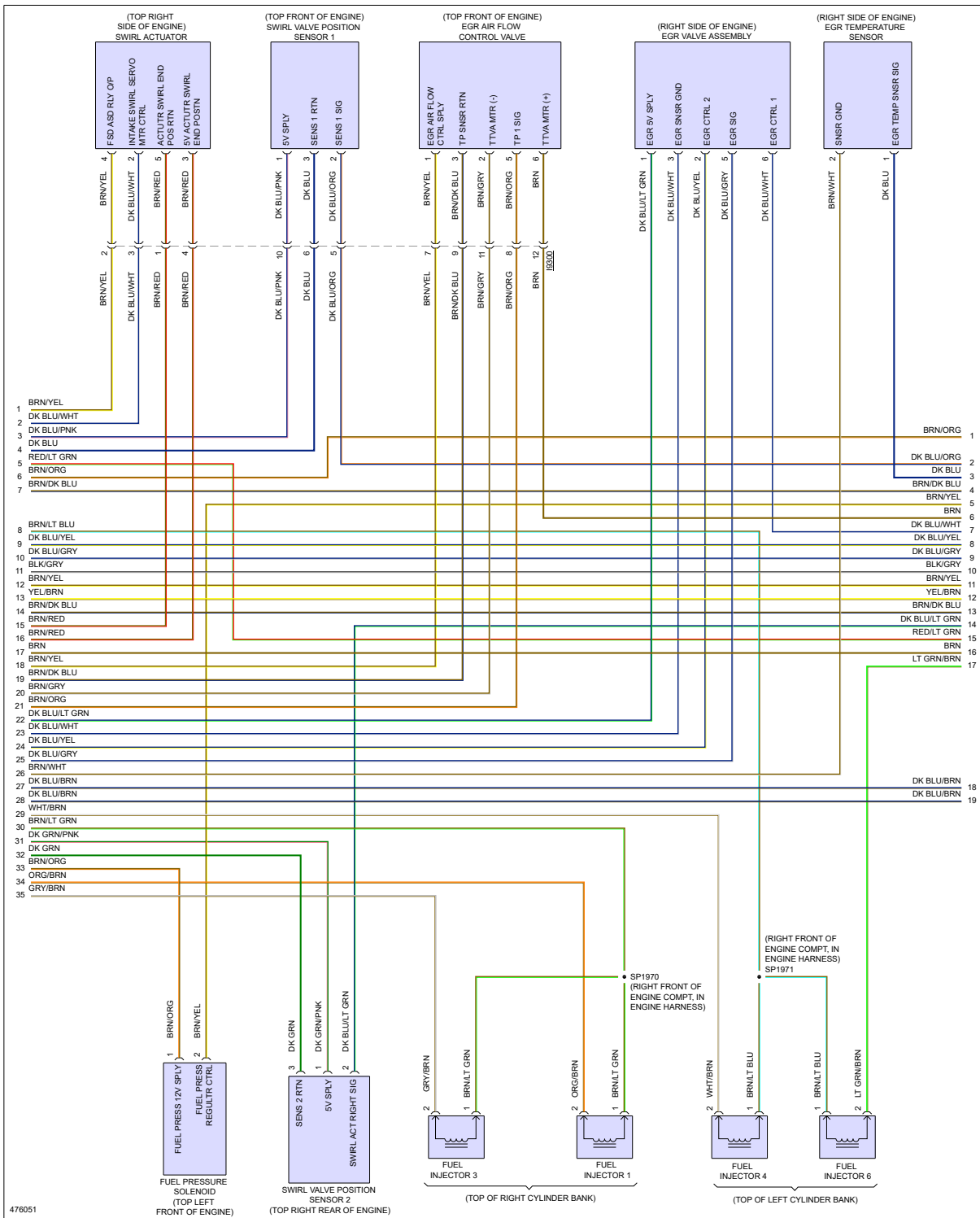

Fig 4: 6.4L, Engine Performance Circuit (4 of 6)

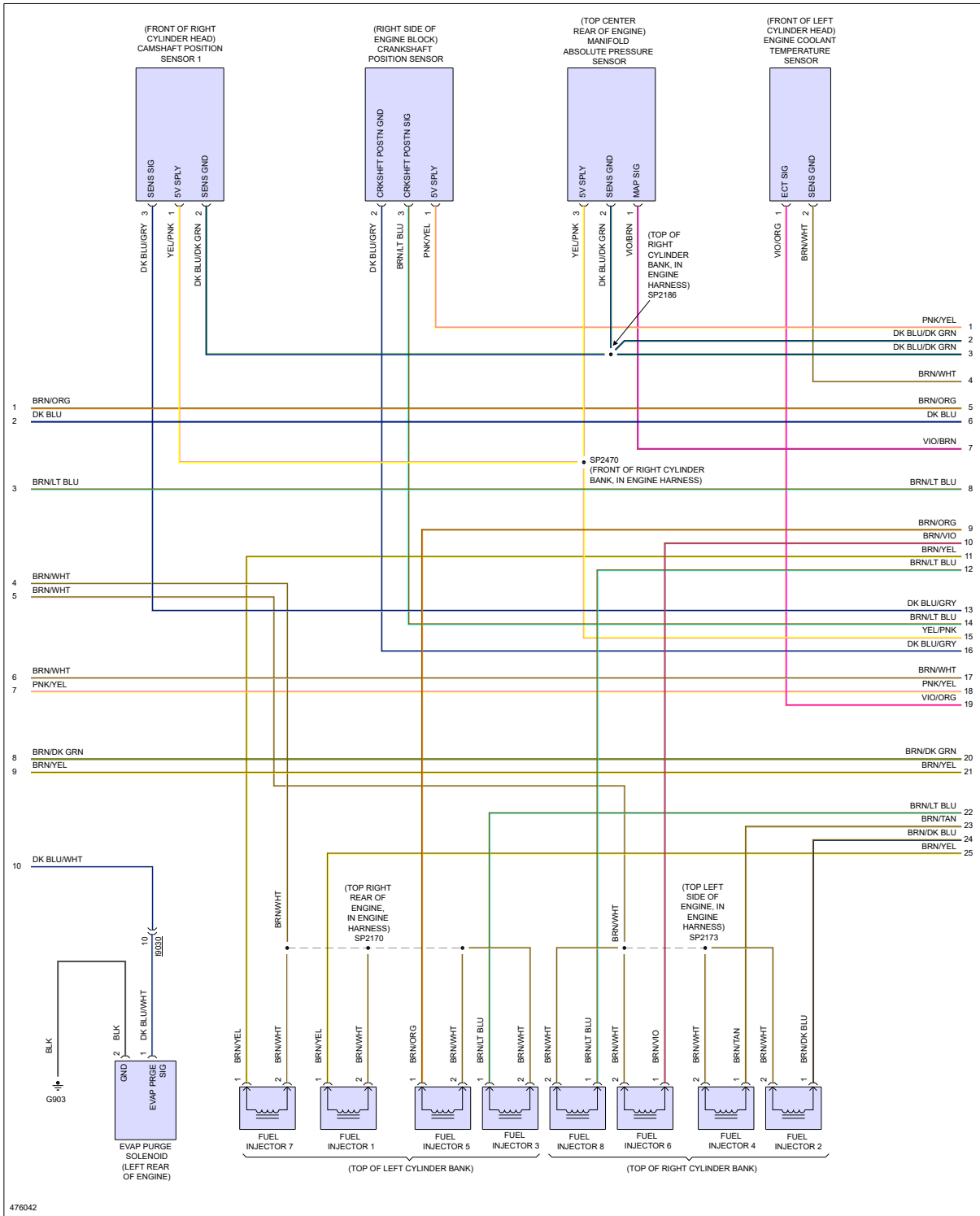

Fig 2: Exterior Lamps Circuit, Base (1 of 2)

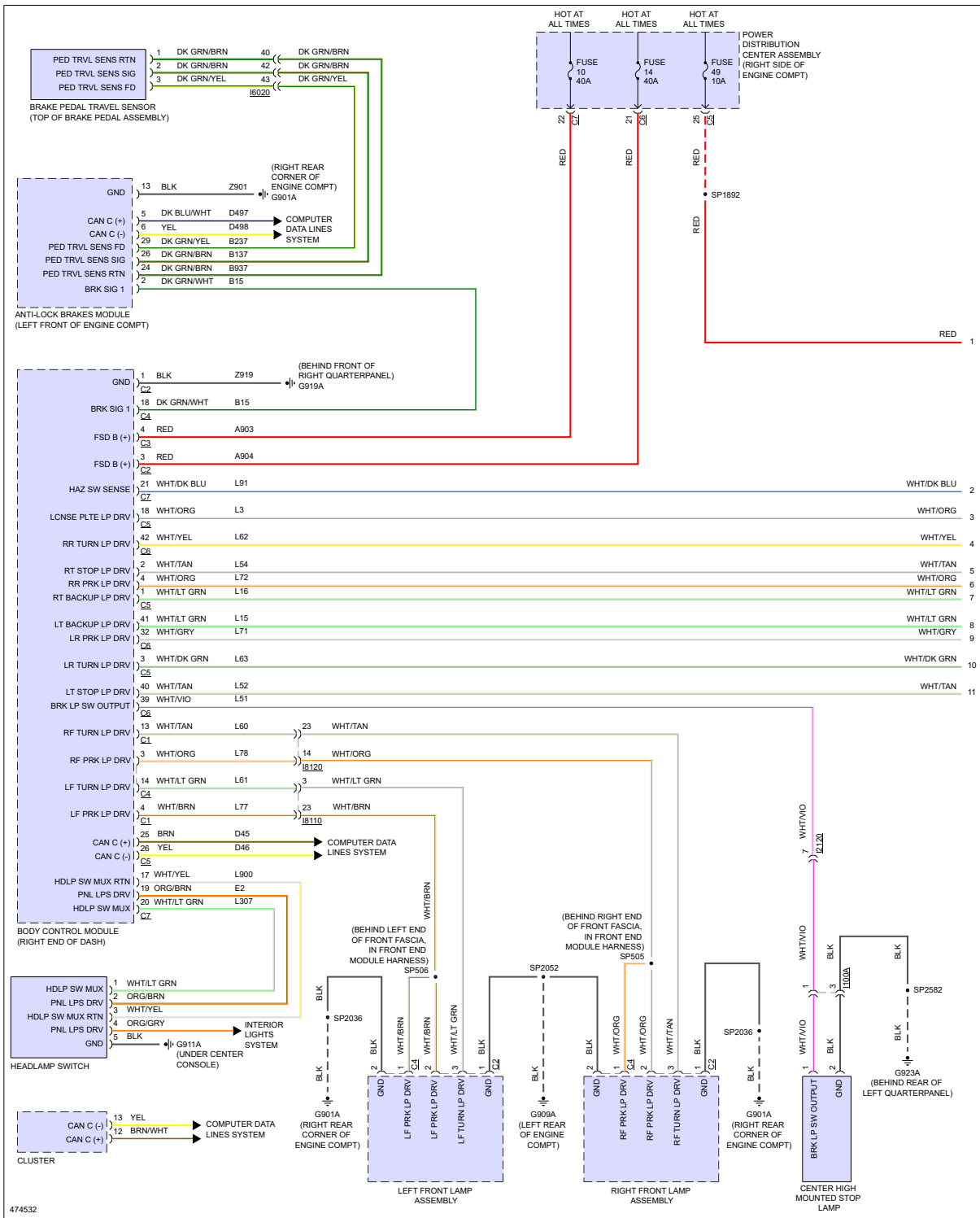
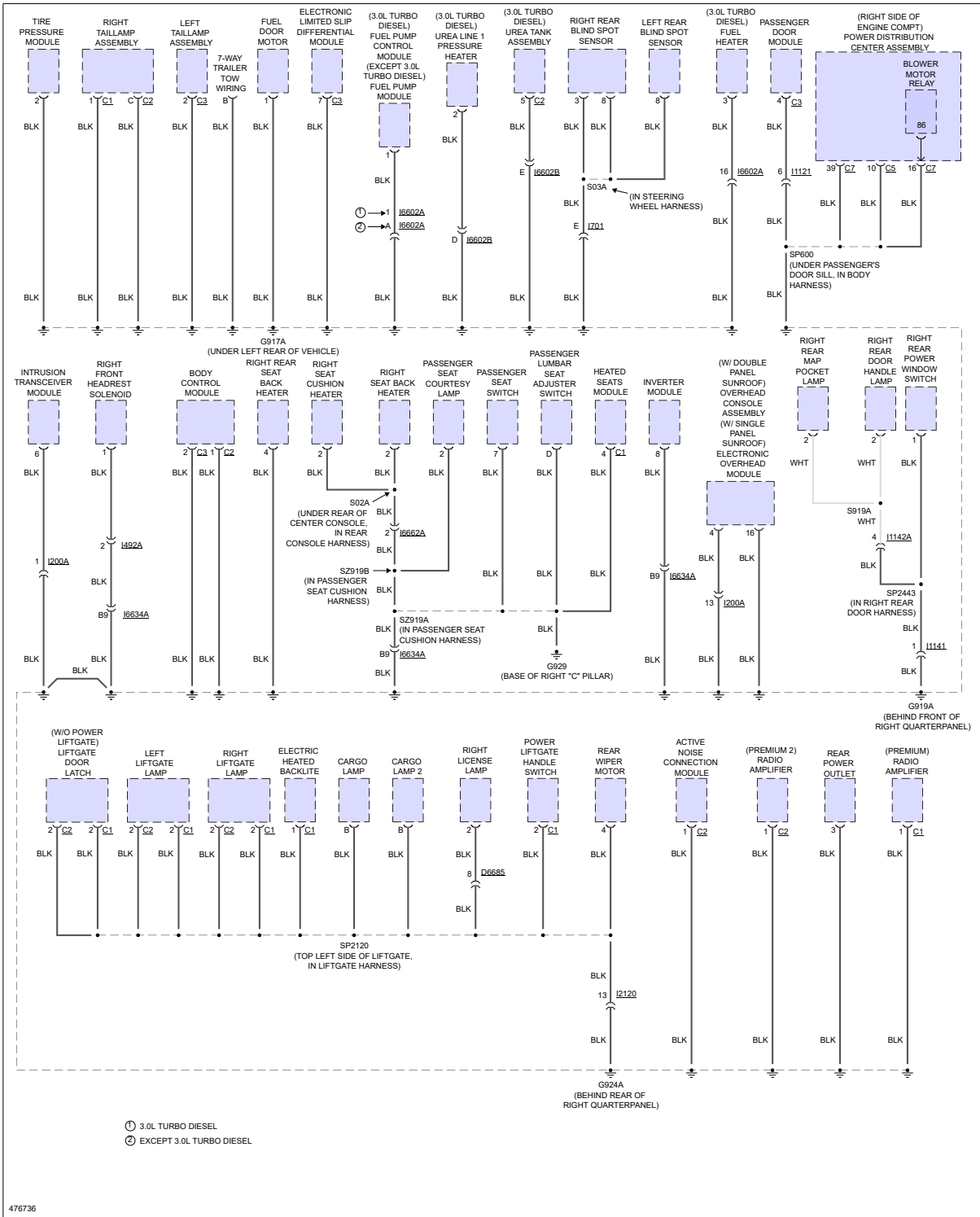

Fig 3: Ground Distribution Circuit (3 of 4)





# INSTRUMENT CLUSTER

Fig 1: Instrument Cluster Circuit (1 of 2)

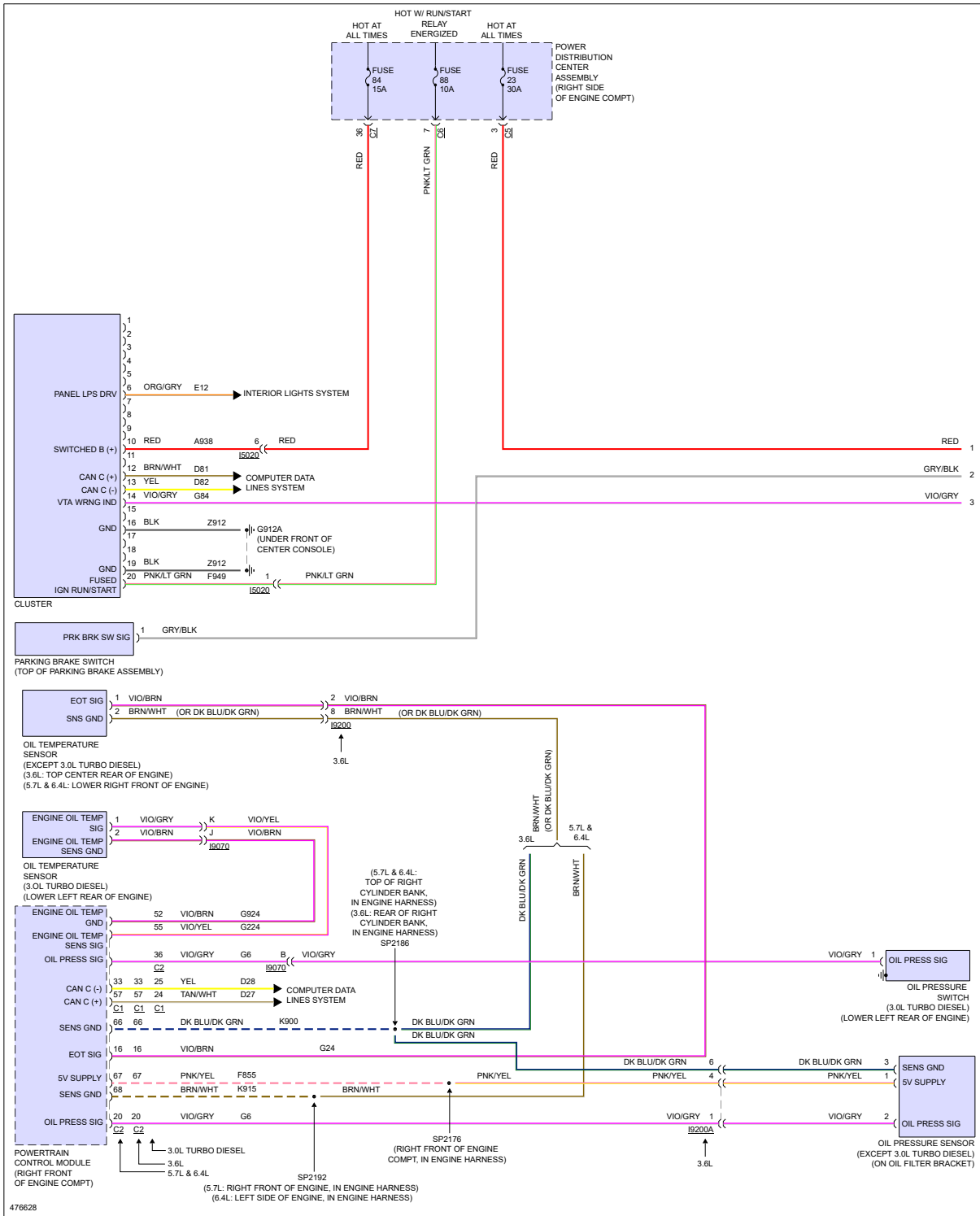

# MEMORY SYSTEMS

Fig 1: Memory Mirrors Circuit (1 of 2)

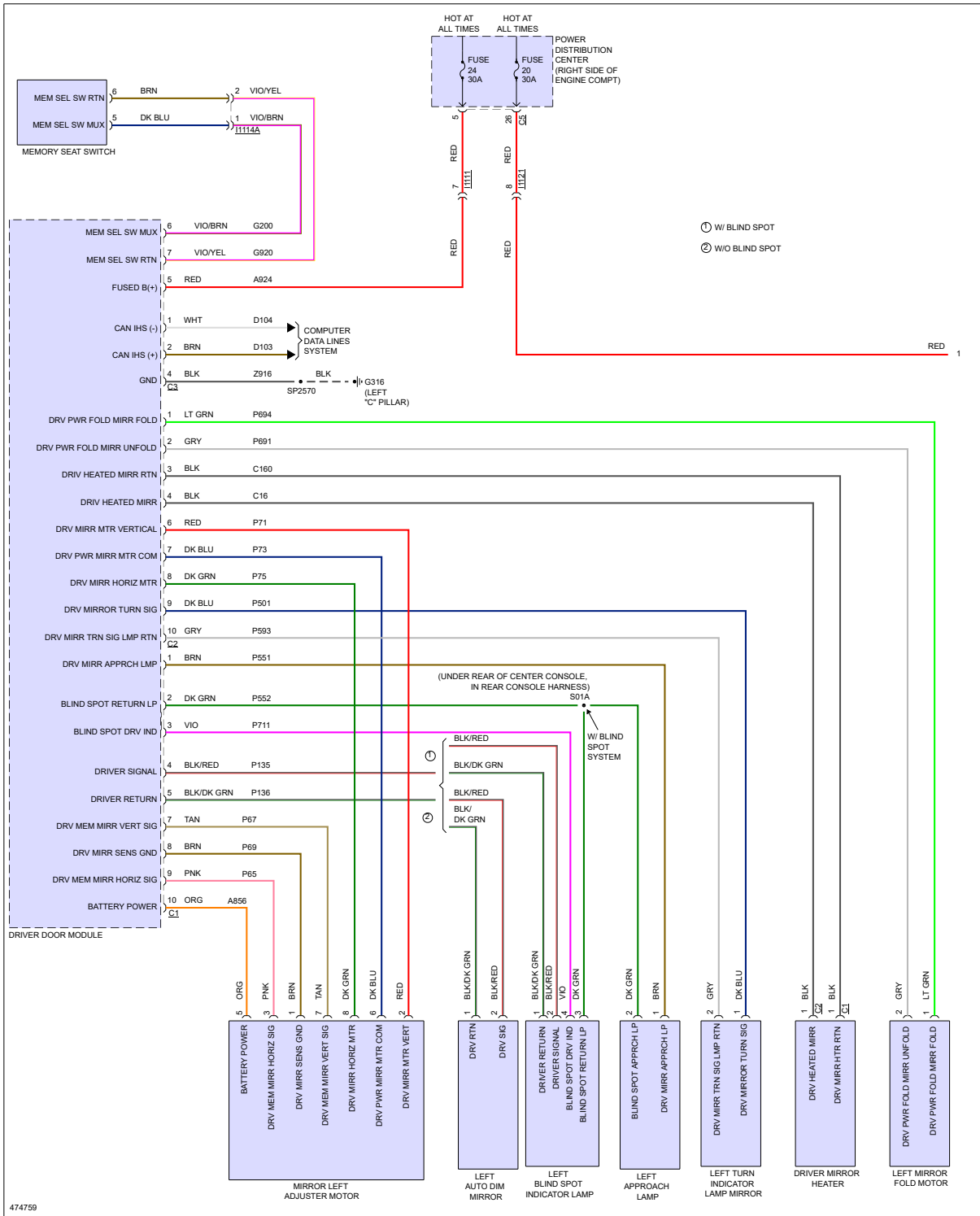

Fig 5: Navigation Circuit, Premium 2 W/ ANC Stand Alone (4 of 6)

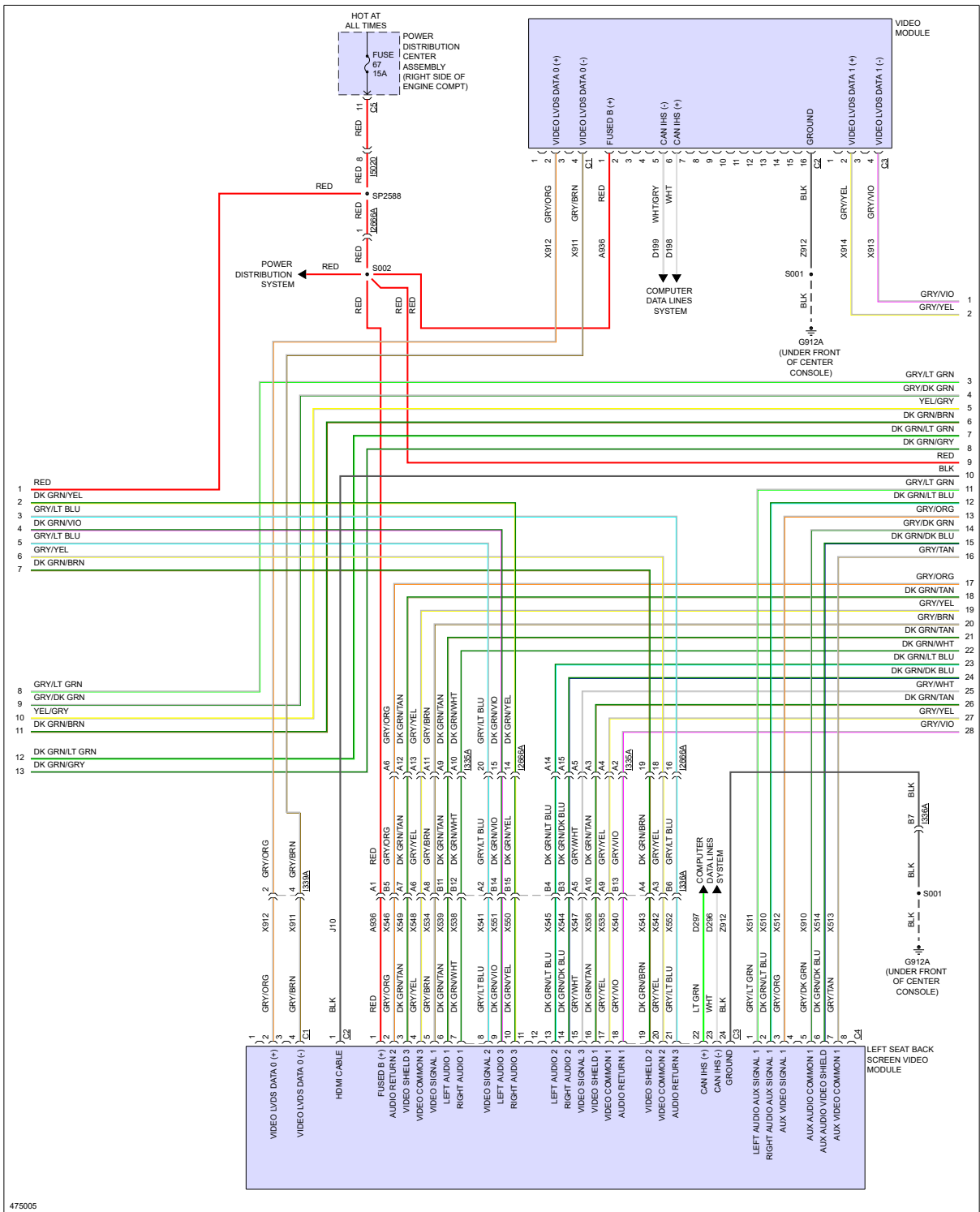
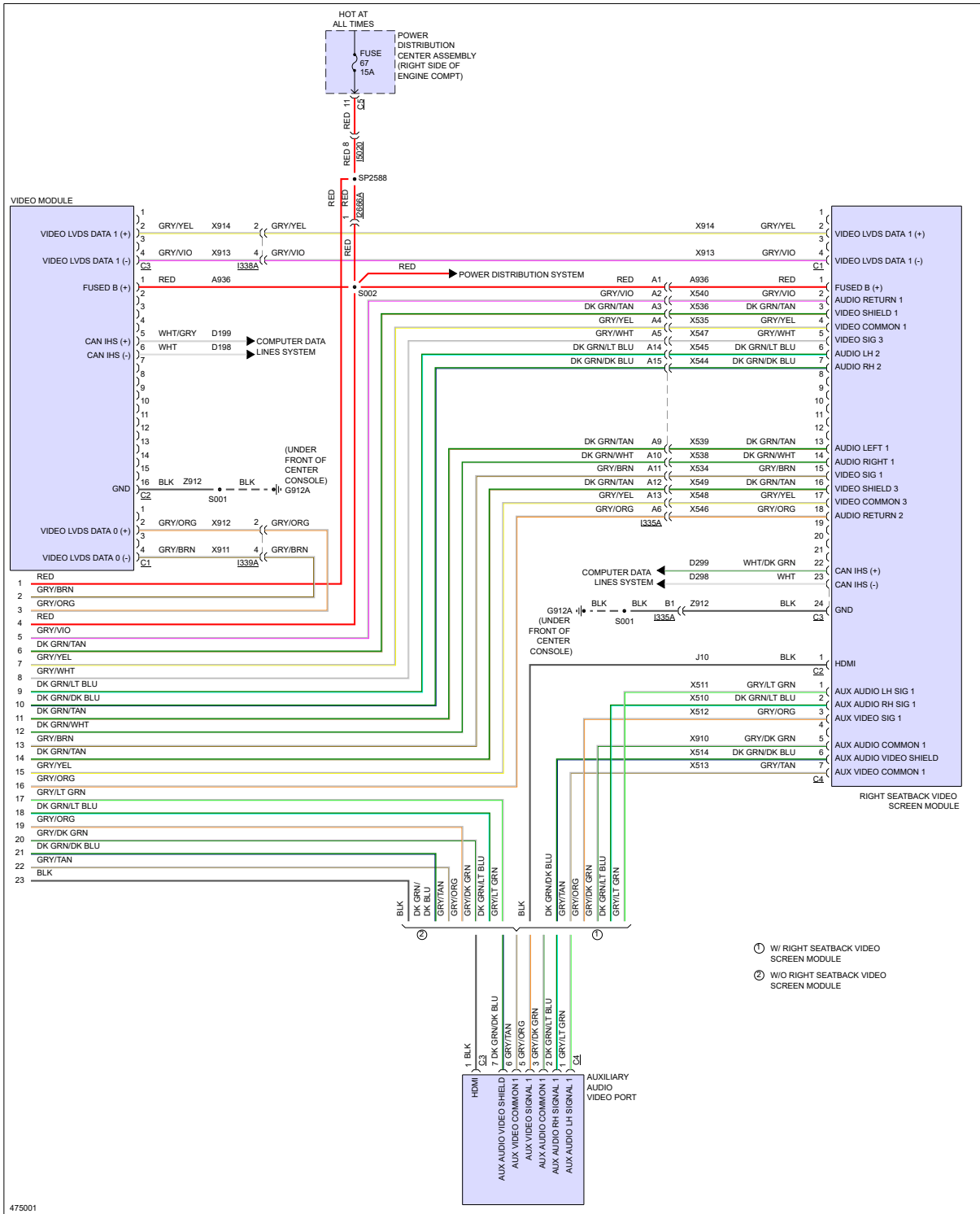
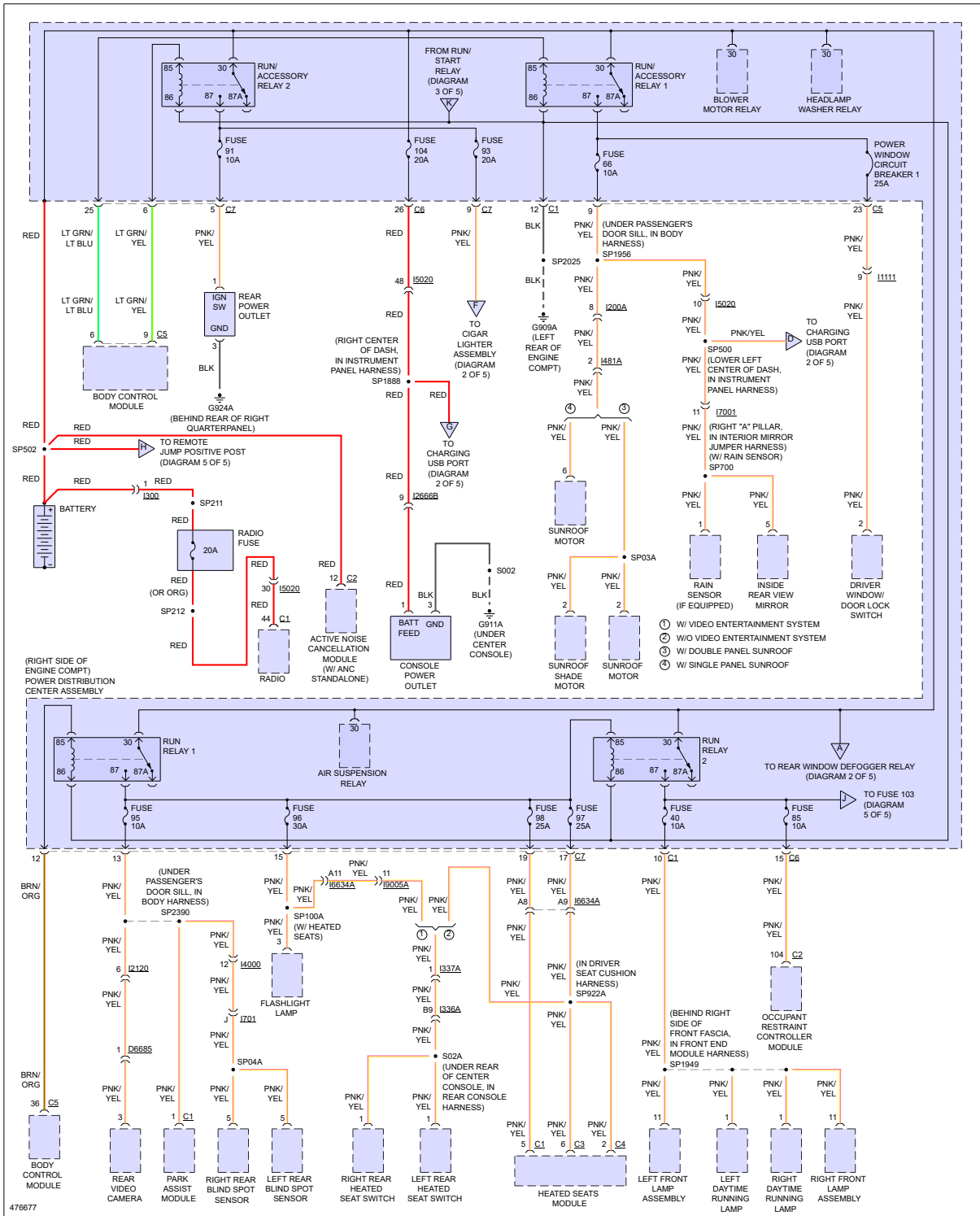

Fig 12: Navigation Circuit, Premium 2 W/O ANC Stand Alone (5 of 5)



# POWER DISTRIBUTION

Fig 1: Power Distribution Circuit (1 of 5)



# POWER MIRRORS

Fig 1: Automatic Day/Night Mirror Circuit

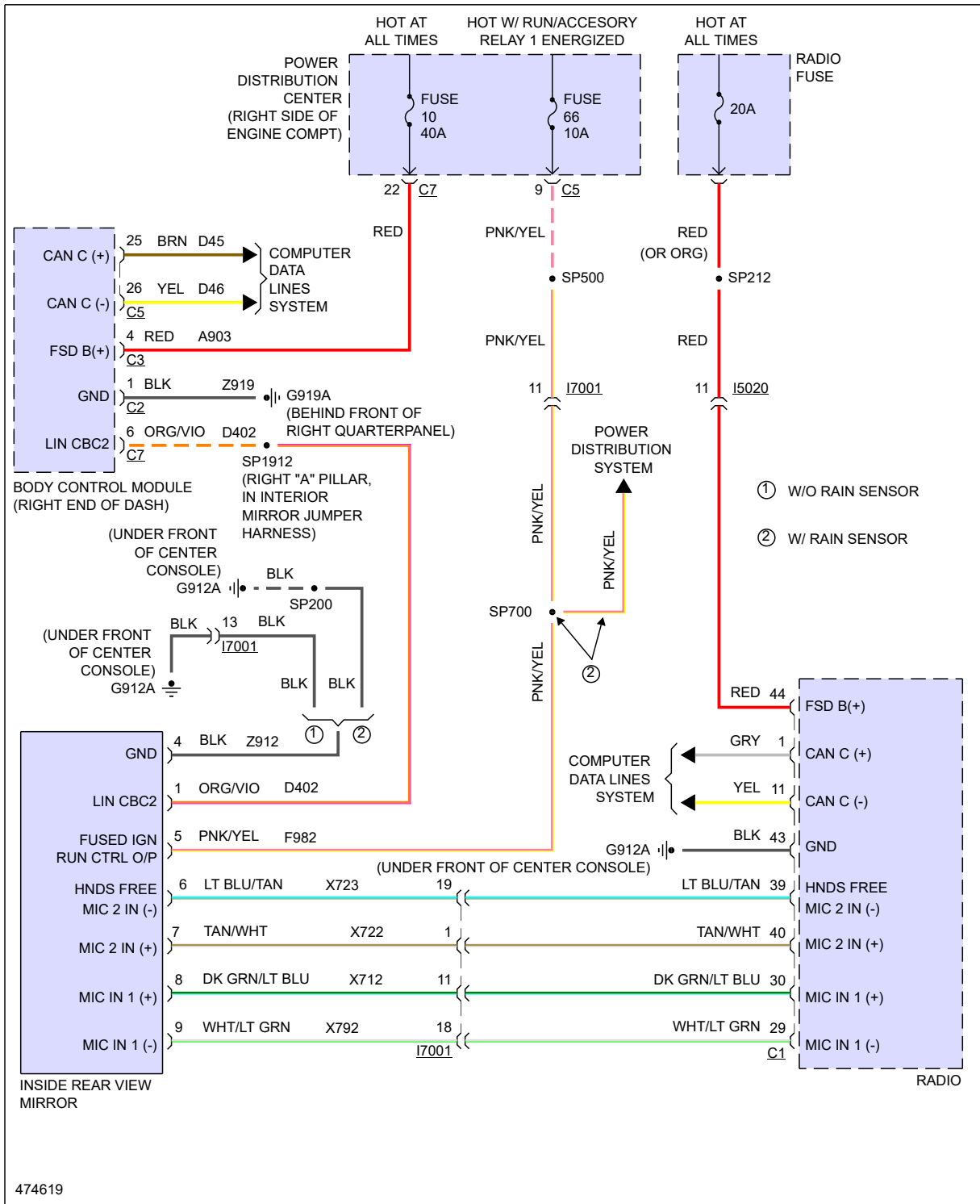

Fig 6: Passenger Power Seat Circuit

