

---

1.Circuit Diagram Reading Instruction	2
2.Icon signals	6
3.Fuse &Relay	8
4.Wiring Harness and connector layout	14
5.Grounding Layout	40
6.Power supplier distribution	56
7.System Diagram	75
8.Abbreviation	398

Electrical Window without anti pinch function 1

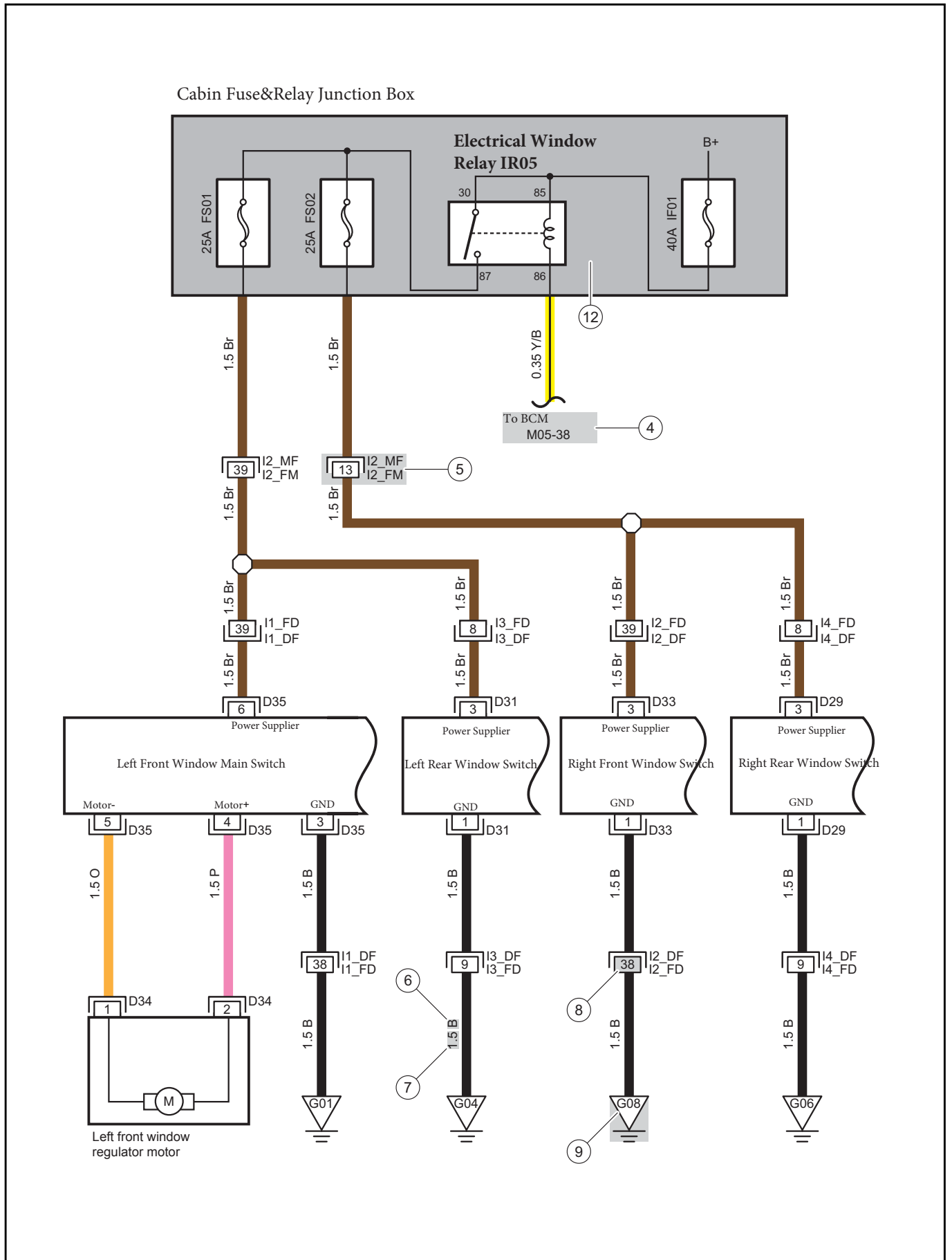

Layout of Main Harness

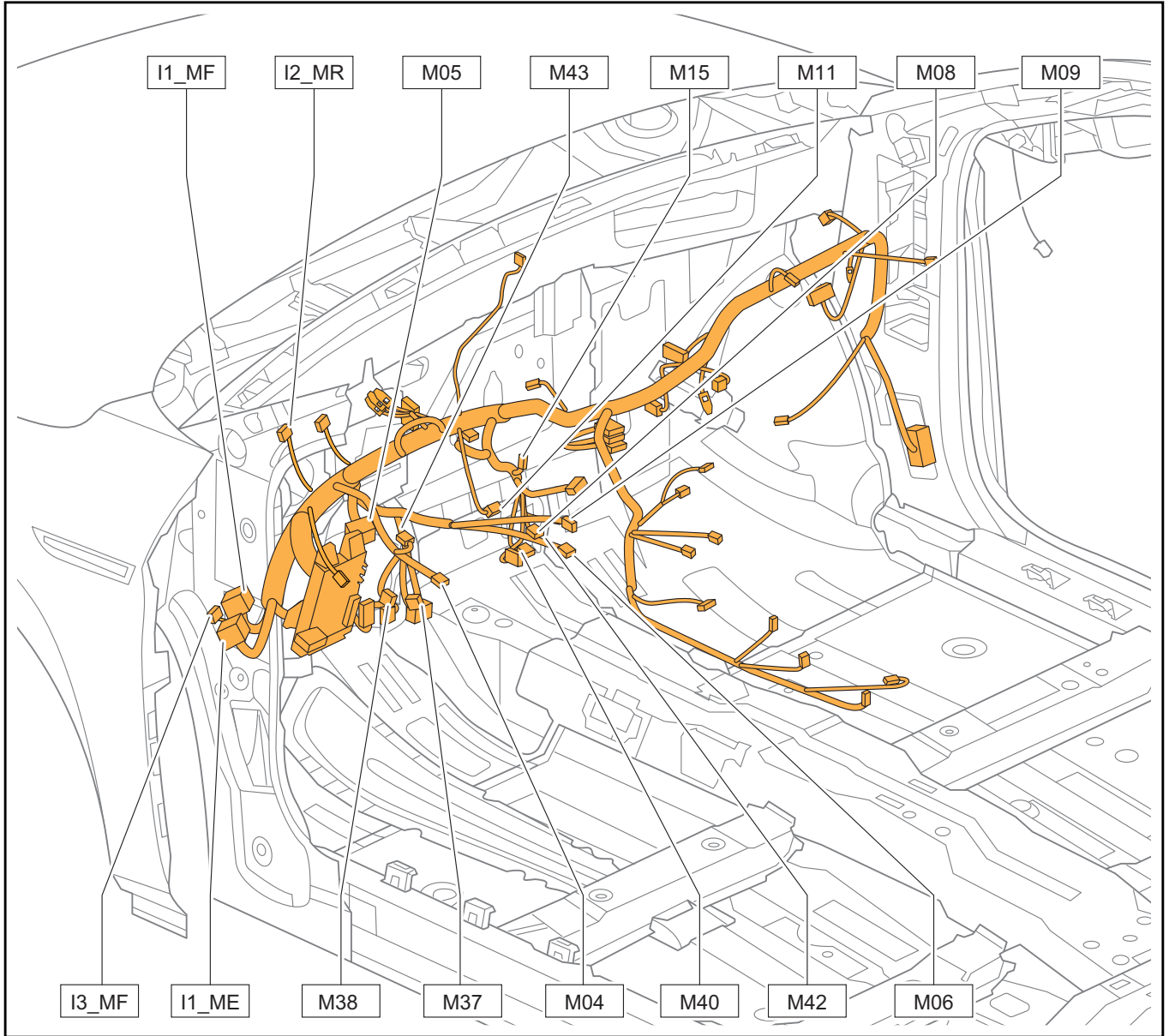

Layout of Roof Harness

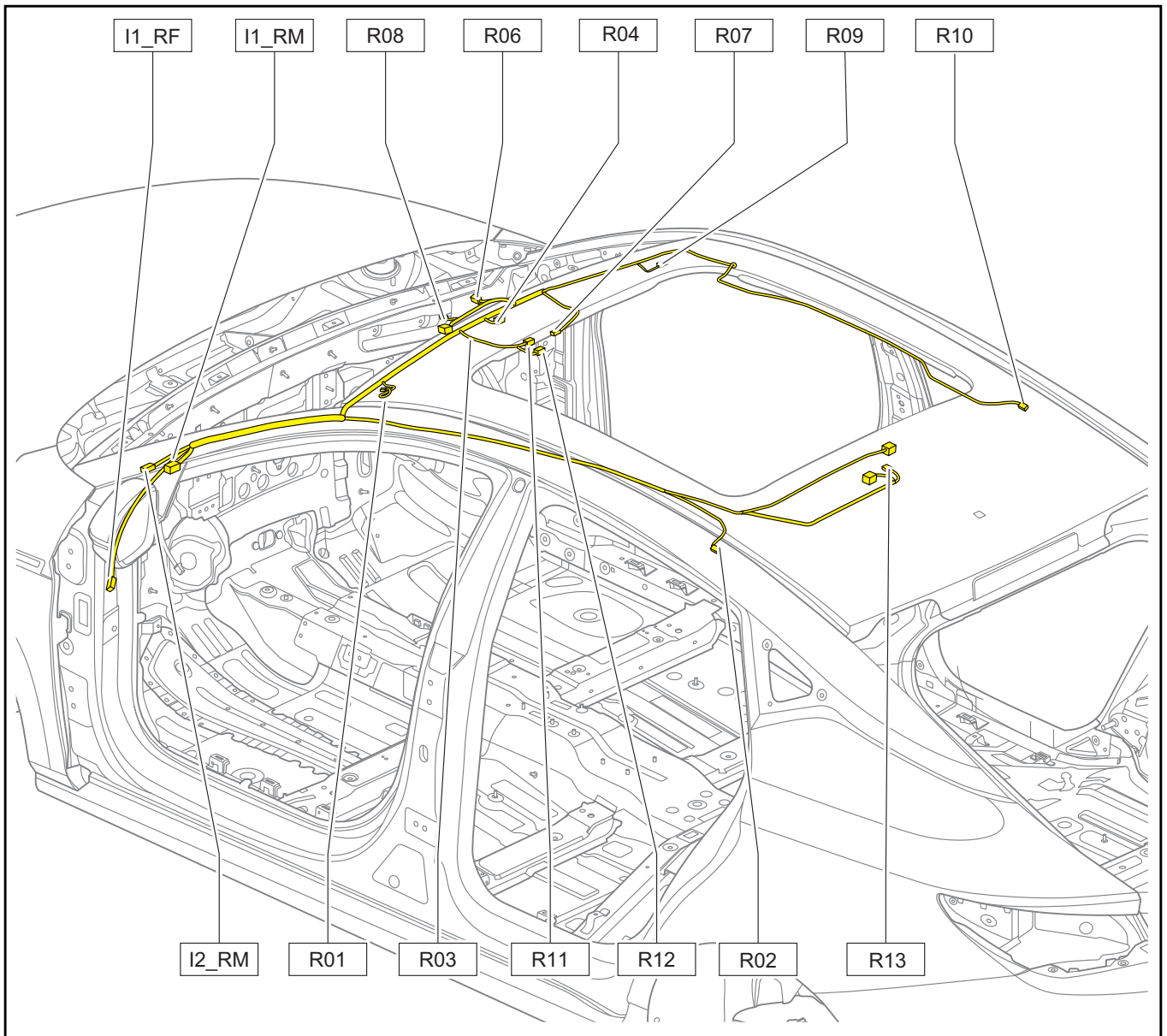

Power Supplier Distribution Diagram 6

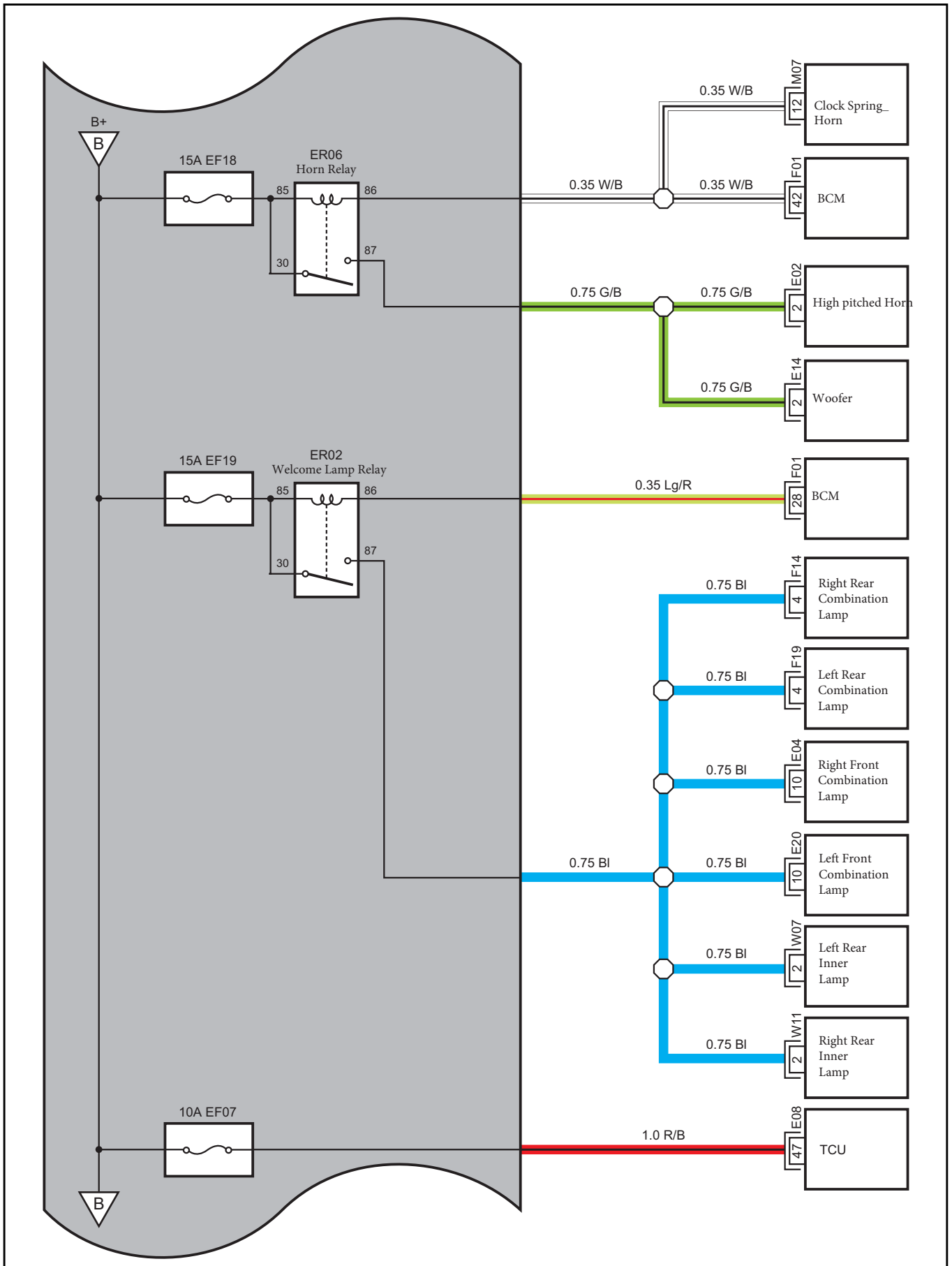

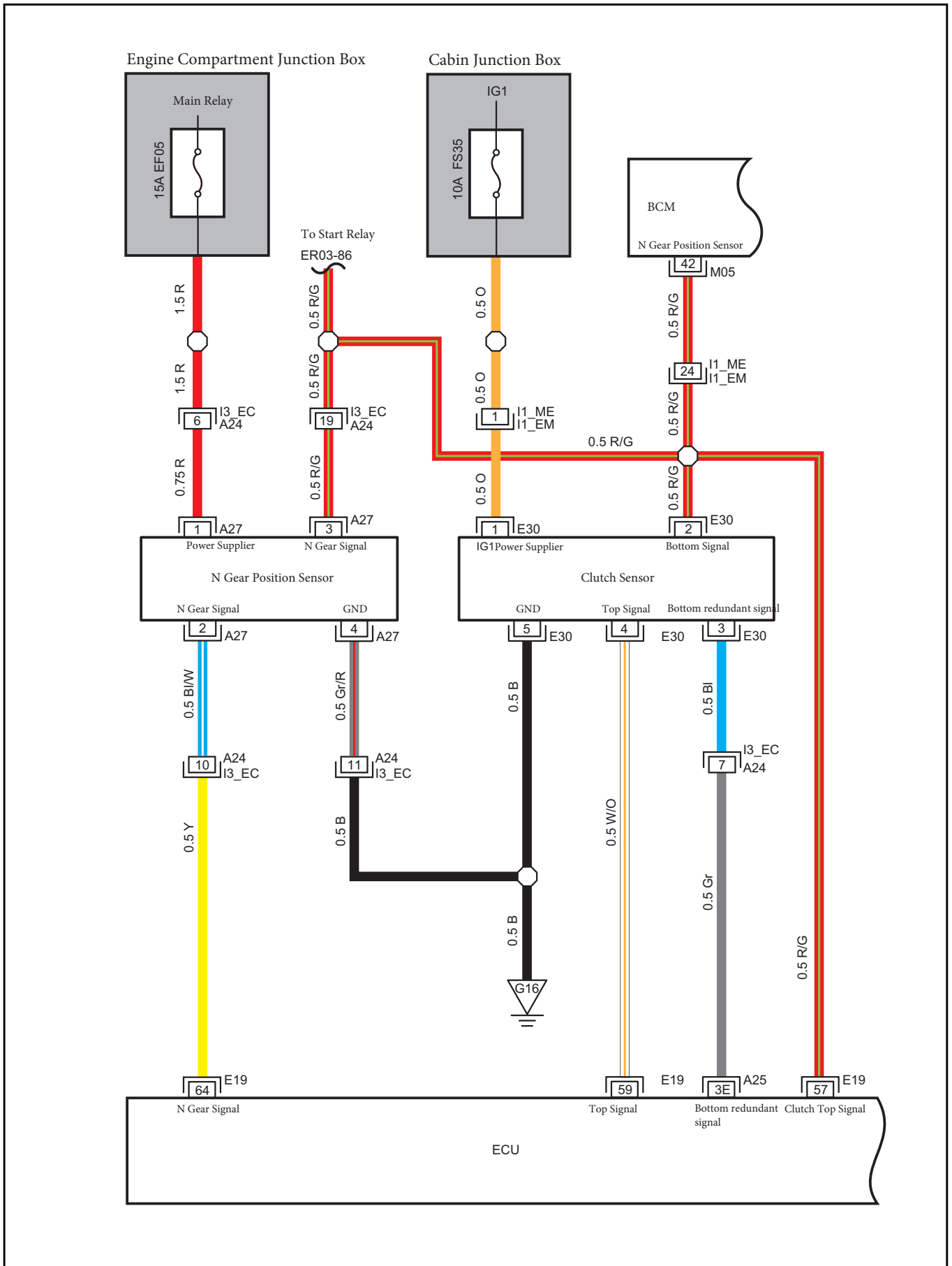

M02 BCM C3

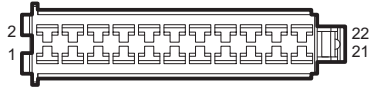

E04 Right Front Combination Light

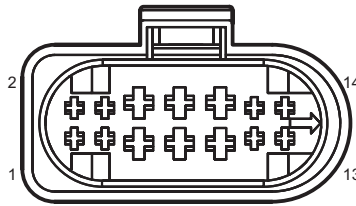

E20 Left Front Combination Light

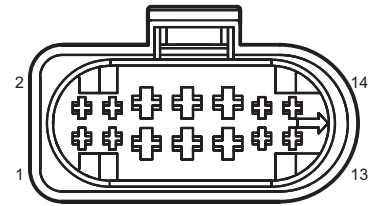

F01 BCM C2

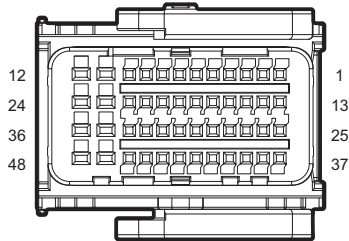

G17 Engine Harness Left GND

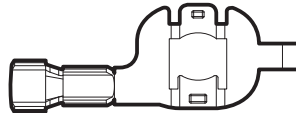

G18 Engine Harness Right GND 1

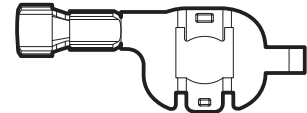

I1\_EF Engine Harness to Body Harness 1

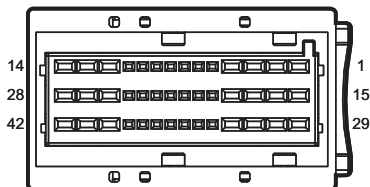

I1\_EM Engine Harness to Main Harness 1

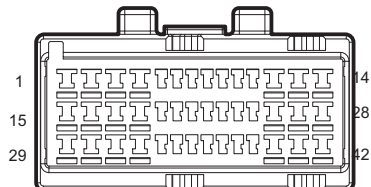

I1\_FE Body Harness to Engine Harness 1

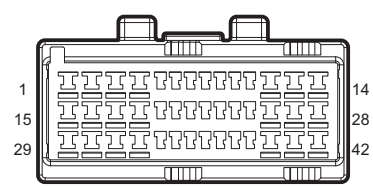

I1\_ME Main Harness to Engine Harness 1

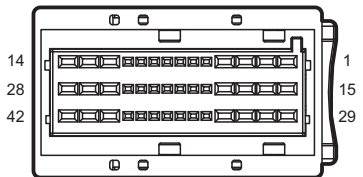

M05 BCM C1

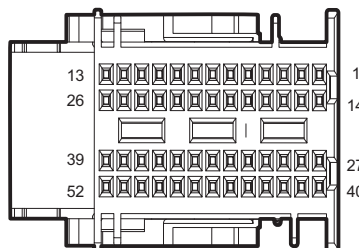

Roof Lamp 1

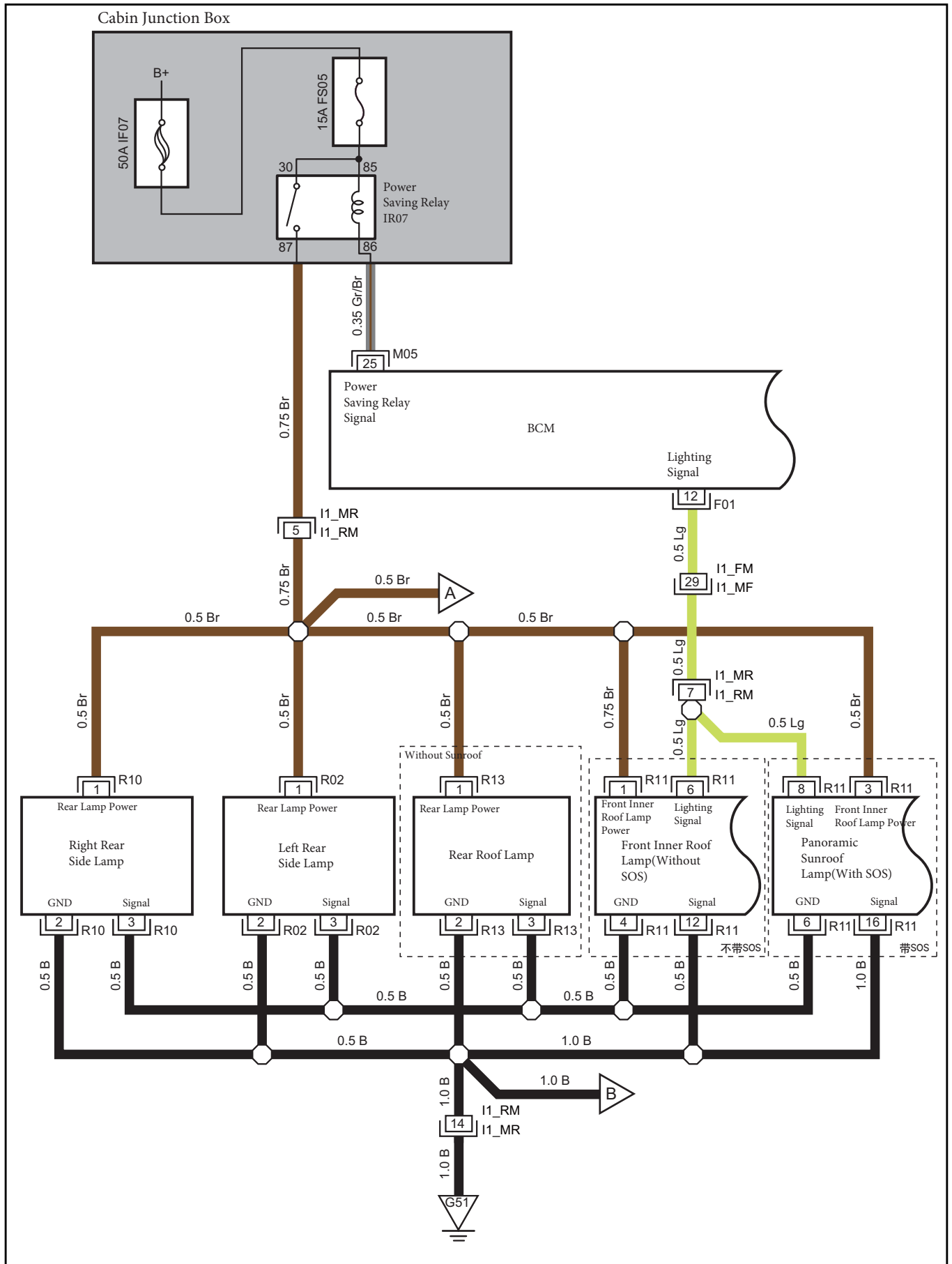



Lock 2

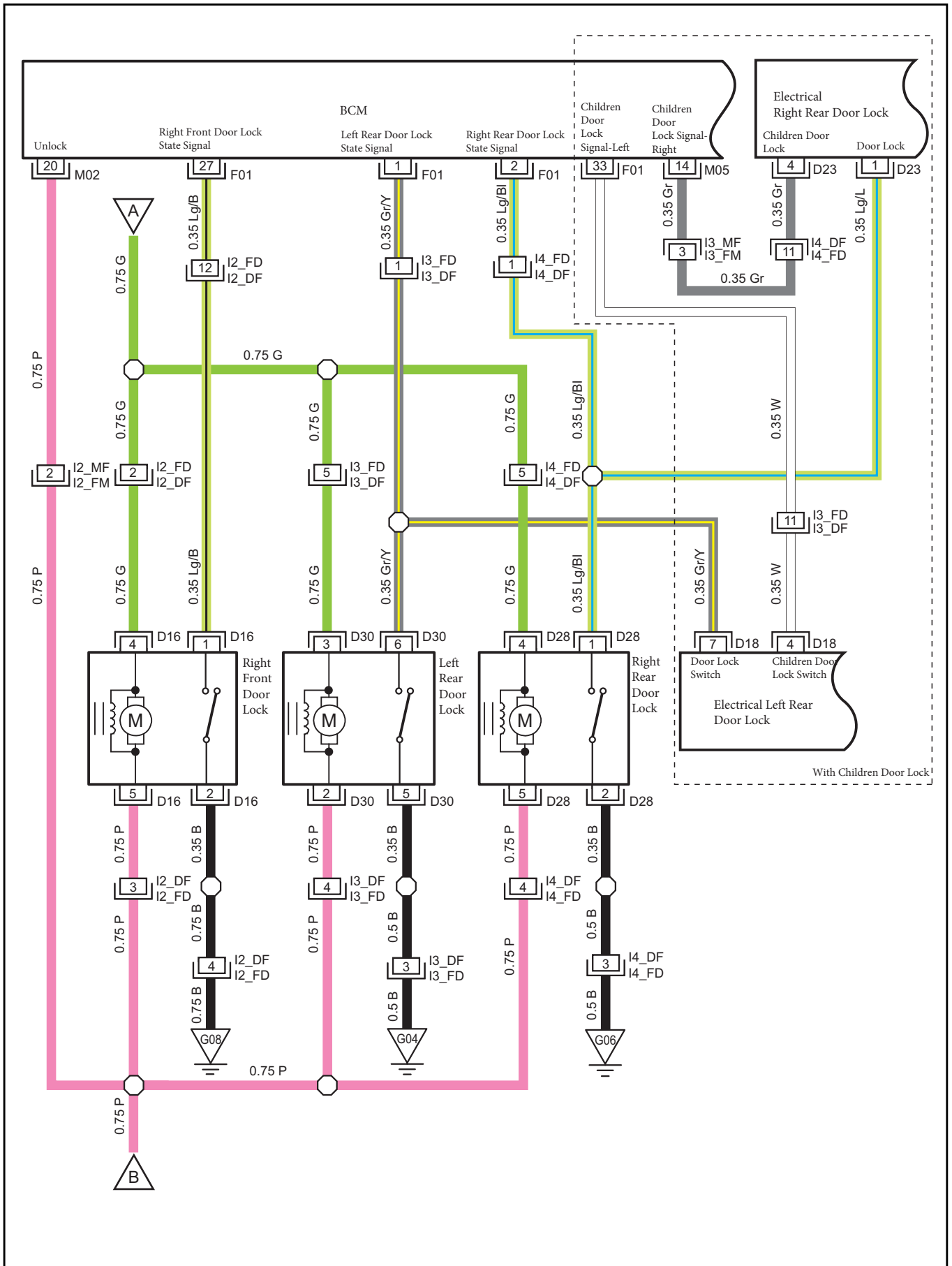

Door Lock UHElectrical Tailgate I

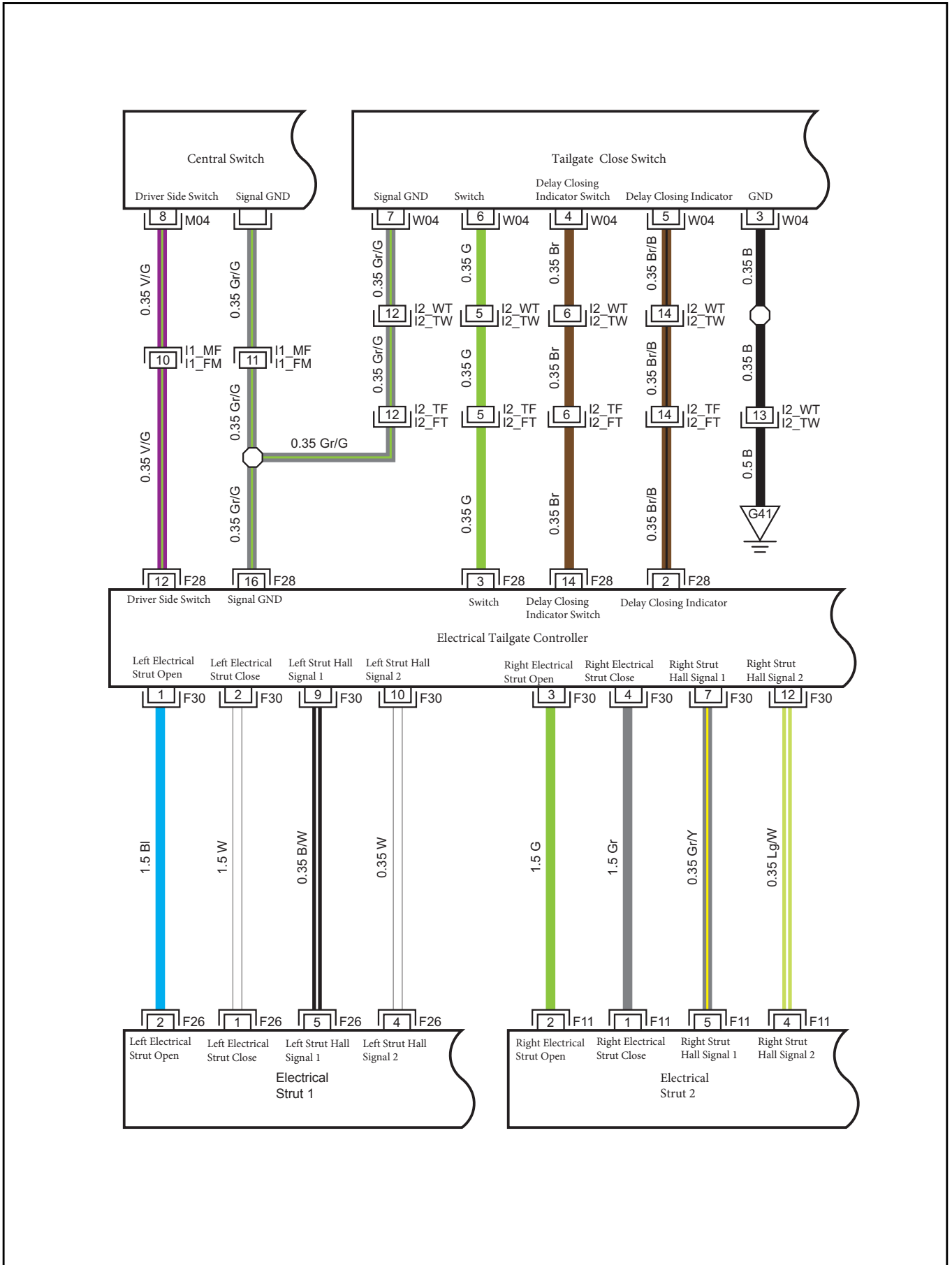

Defrost

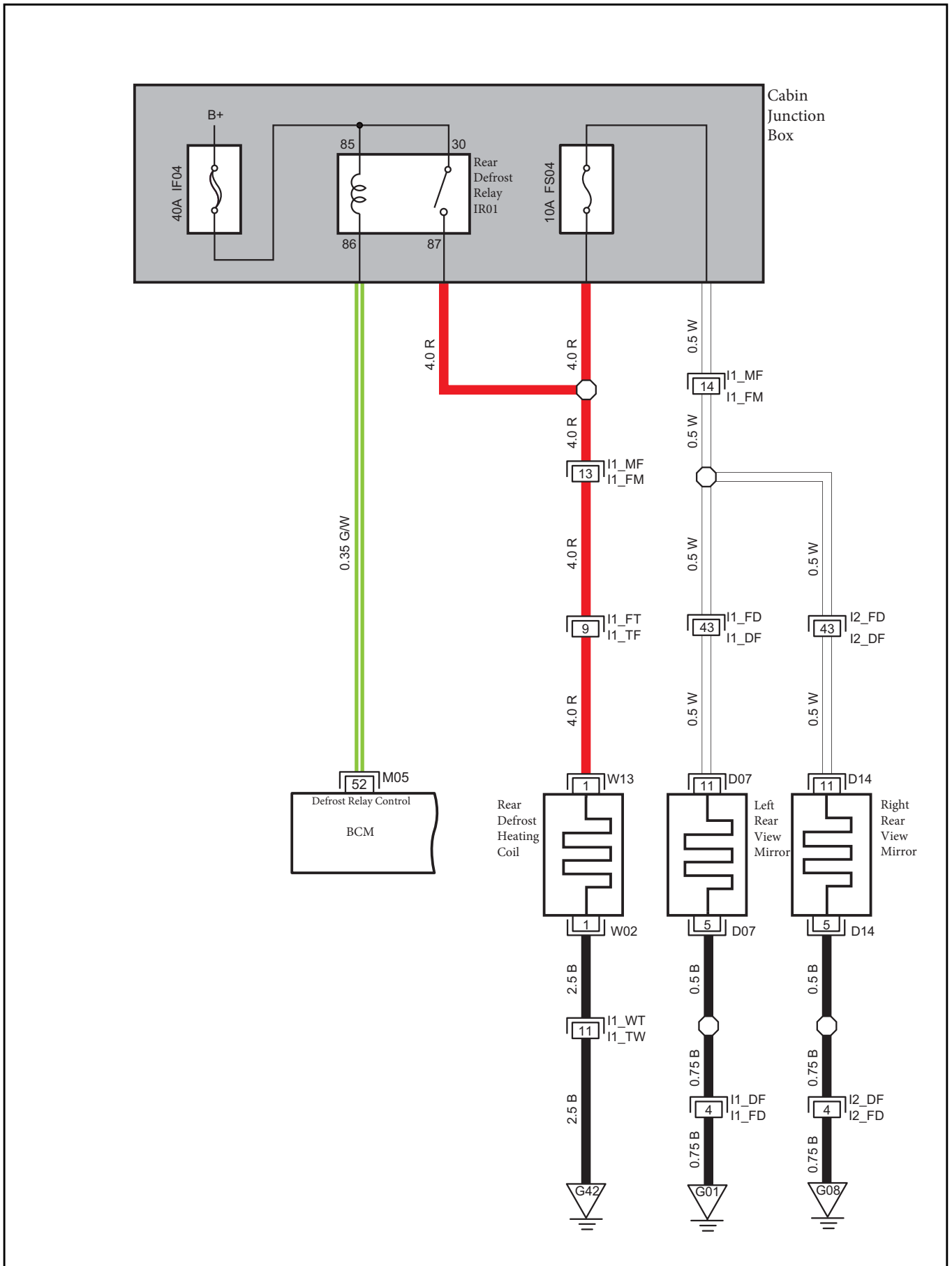

Sunroof(Single)

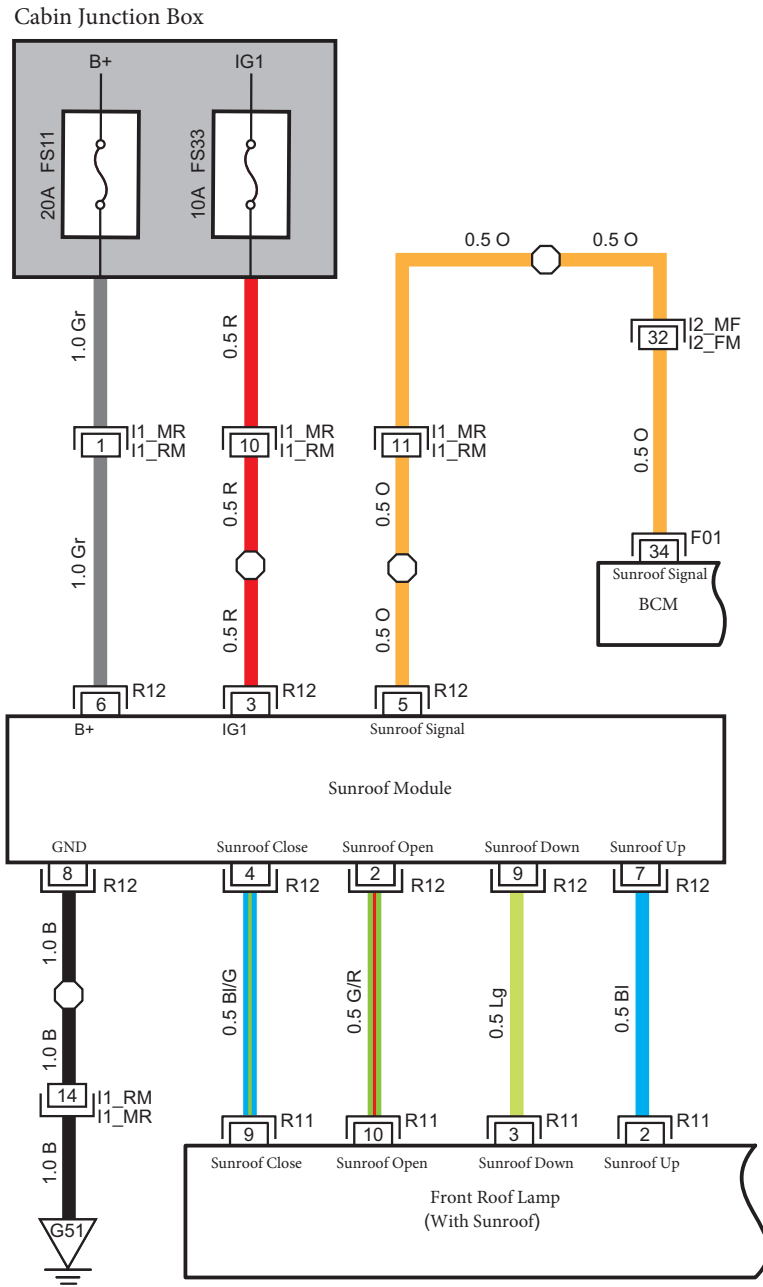

Harness Connector	Name	Page
dPU	Left Front Door Main Switch(High Spec)	RY
dQR	Right Front Door Switch(High Spec)	SQ
dQY	Left Rear Door Switch(High Spec)	SP
dRT	Right Rear Door Switch(High Spec)	SR
fPS	Electrical Window Anti Pinch Module C2	RU
iQ <sub>i</sub> df	Left Front Door Harness to Body Harness	RY
iQ <sub>i</sub> fd	Body Harness to Left Front Door Harness	RU
iR <sub>i</sub> df	Right Front Door Harness to Body Harness	SQ
iR <sub>i</sub> fd	Body Harness to Right Front Door Harness	RV
iS <sub>i</sub> df	Left Rear Door Harness to Body Harness	SP
iS <sub>i</sub> fd	Body Harness to Left Rear Door Harness	RV
iT <sub>i</sub> df	Right Rear Door Harness to Body Harness	SR
iT <sub>i</sub> fd	Body Harness to Right Rear Door Harness	RV
gPT	Body Harness Left Rear GND	TT
gPV	Body Harness Right Rear GND	TT
gPX	Body Harness Right Front GND	TT

Audio 3

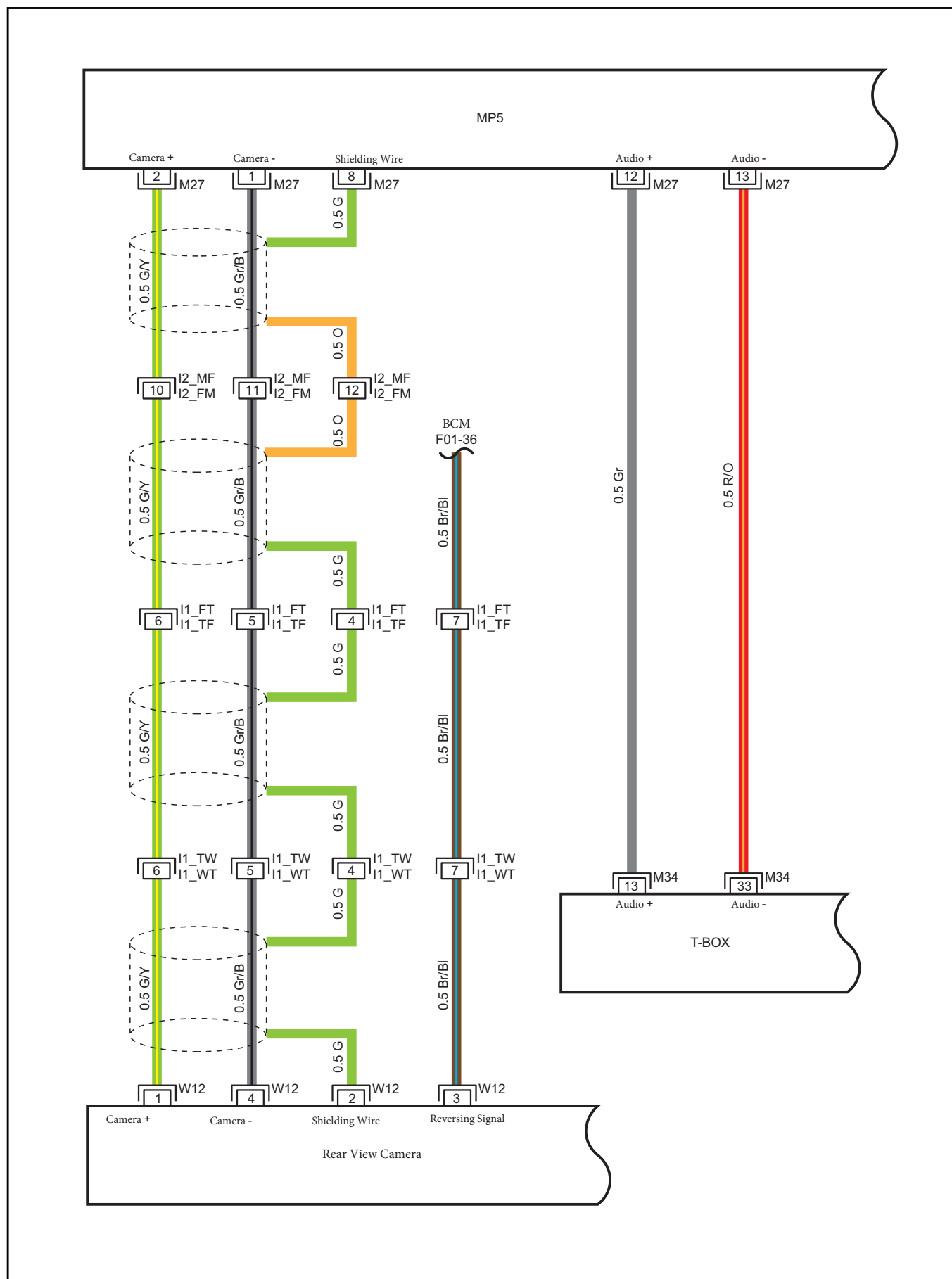

---

Harness Connector	Name	Page
fRP	Trunk Power	RV
fTW	Rear USB Connector	RU
iR <sub>i</sub> fm	Body Harness to Main Harness II	RV
iR <sub>j</sub> mf	Main Harness to Body Harness II	RQ
iS <sub>i</sub> fm	Body Harness to Main Harness III	RU
iS <sub>j</sub> mf	Main Harness to Body Harness III	RP
mRV	Front On-board Power	RQ
gPS	Body Harness Left Middle GND	TT
gPU	Body Harness Left Rear GND 2	TT
gUQ	Main Harness Left GND a	TS
gUS	Main Harness Left Middle GND a	TS
mRT	Wireless Charging	RQ
mRU	Left Front USB Charging Port	RQ

---