

Sub-volume Workshop for Circuit Service

How to use this Manual.....	1
Instructions.....	1
Notation.....	7
Failure checking guide.....	14
Circuit Diagram.....	21
Power distribution system.....	21
Start system.....	33
Charging system.....	35
Engine ECU system.....	37
Reversing system.....	48
ACC system - CD player.....	50
ACC system - cigarette lighter.....	52
Lighting – headlamp.....	53
Lighting - small light.....	54
Lighting - front and rear fog light.....	56
Lighting - combination light switch.....	57
Lighting - turning light, hazard warning light.....	58
Lighting.....	59
BCM system.....	61
Electric rearview mirror.....	70
Wiper and washer system.....	72
Combination switch - wiper.....	73
Air bag.....	74
Diagnosis system.....	76
ABS/Brake system.....	77
Auto A/C system.....	79
A/C system - Mode, Temp actuator.....	80
A/C system – Compressor.....	81
A/C system - Mode, Temp actuator.....	82
Manual A/C system - Blower.....	84
Manual A/C system - Mode, Temp actuator.....	85
Manual A/C system - Compressor.....	86
Instrument cluster.....	88

IMMO.....91
 Electric glass lifting.....92
 Door lock.....97
 Door switch.....100
 TPMS105

Component Location.....106

ABS wire harness.....106
 CD audio.....107
 Rearview mirror door wire harness.....108
 A/C wire hareness.....112
 Airbag wire harness.....114
 Front wall wire harness.....115
 Tail door wire harness and sensor wire harness.....116
 Wire harness of instrument desk.....118
 Seat room wire harness.....121
 Engine cabin wire harness.....123
 Ground point.....128

Wire hareness layout.....130

Main wire harness.....130
 Engine wire hareness.....132
 Indoor junction box.....134
 Body wire harness.....136
 Airbag wire harness.....138
 Ceiling wire harness.....140
 Left/right front door wire harness.....142
 Rear door wire hareness.....144

To diagnose and remove the faults, it shall firstly know the circuit diagram sufficiently.

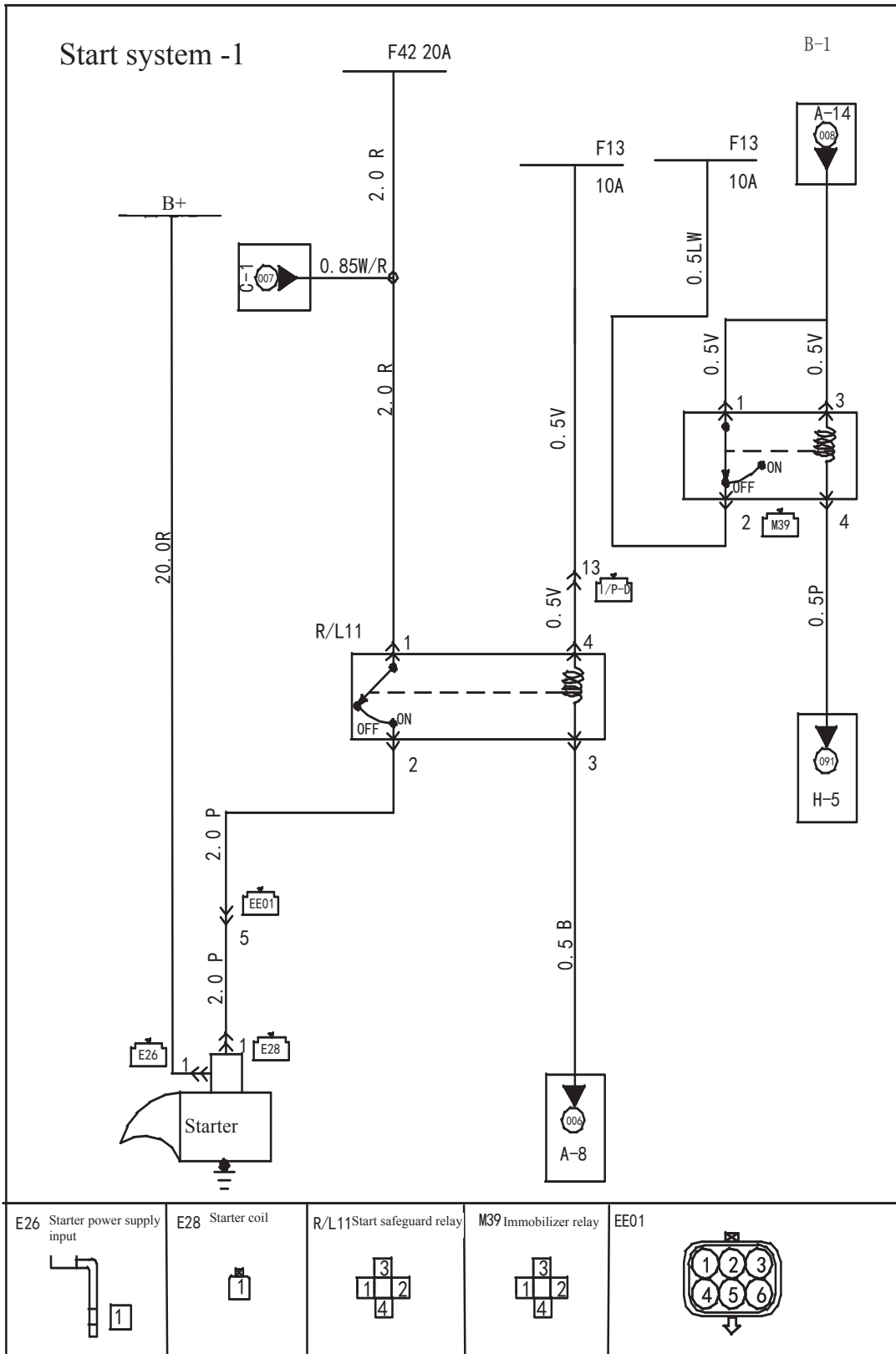

Notation

This Manual uses the following electrical notations, electrical symbols and abbreviated names.

1. Notation in circuit diagram

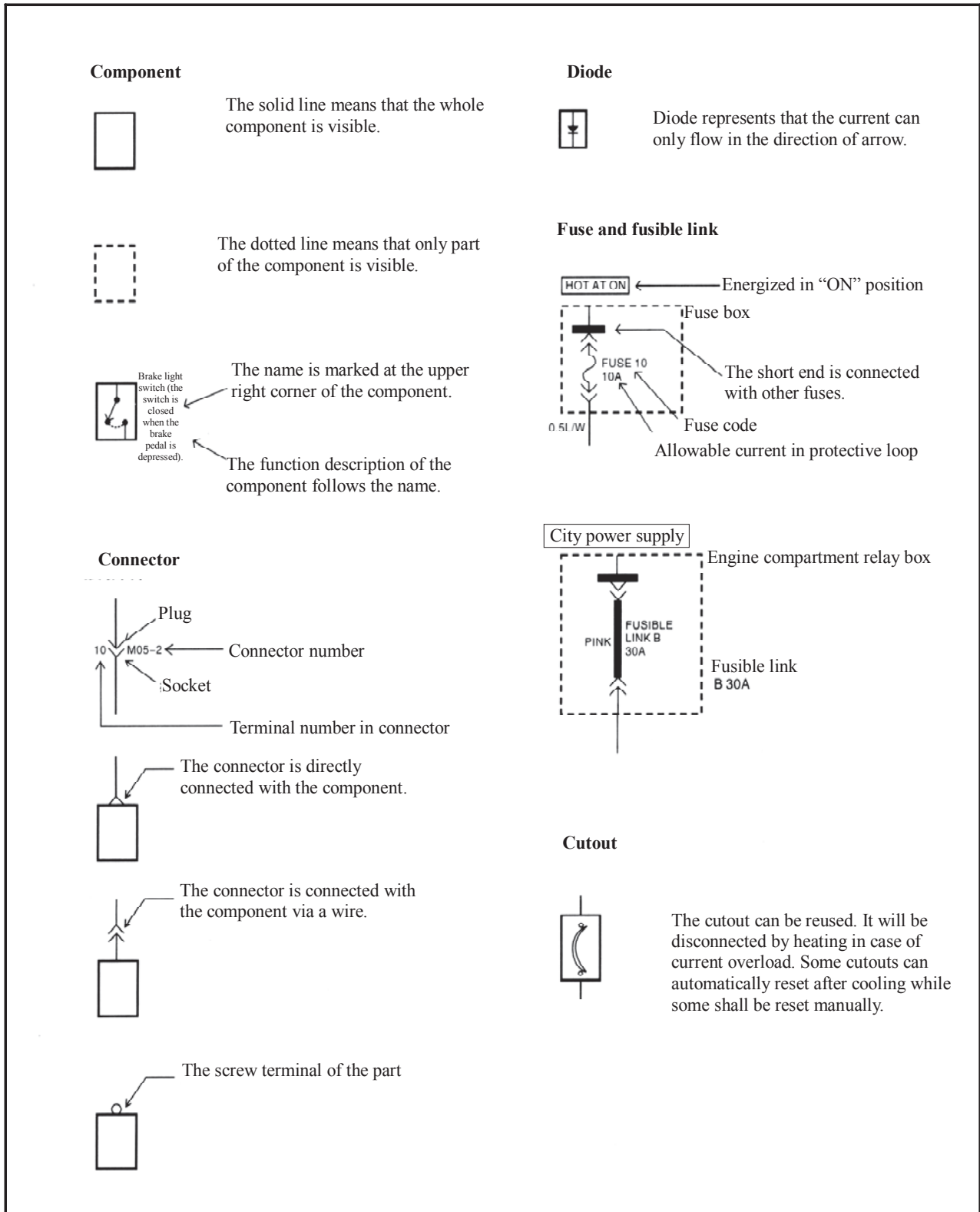

3. Guide wire color description

Wire color	Code	Wire color	Code
Black	B	Orange	O
Blue	L	Pink	P
Brown	Br	Red	R
Green	G	Purple	V
Gray	Gr	Yellow	Y
Light green	Lg	White	W

4. Wire harness identifying marking and system function paging code

Divide the guide wire into the following types according to different positions of the wire:

Wire Harness Name	Connector Code
Main wire harness	M
Engine cabin wire harness, power supply wire harness	E
Control wire harness	C
Frame wire harness	F
Door wire harness	D
Tail door wire harness, ceiling wire harness	R
Reverse radar sensor wire harness	F
Air bag wire harness	A
Grounding	G

5. Identification of wire connector code

The guide wire connector identification code comprises of wire harness position identification code and wire connector identification code. Refer to wire harness layout for the guide wire connector positions

For instance:

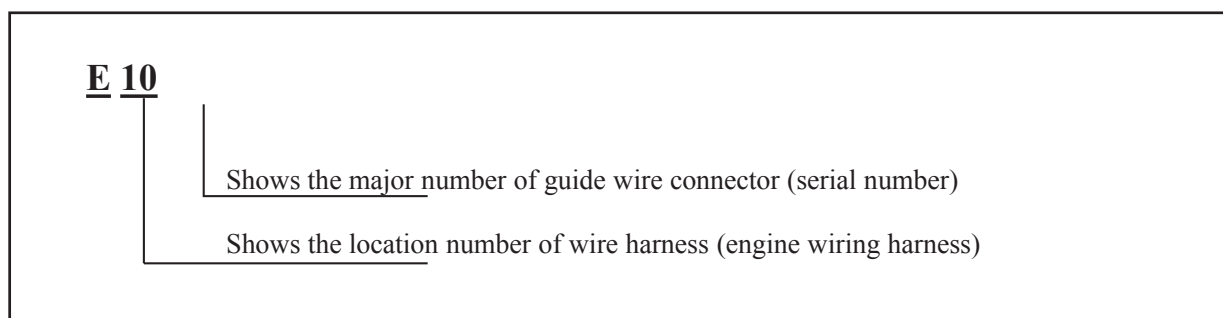

Warning

To protect the tested circuit, do not use jumper with fuse wire larger than the rated capacity. Neither can it use jumper wire instead of input or output signal when connecting to the control modules such as ECM and TCM.

2. Short-circuit test

- ① Dismantle the negative terminal of the battery
- ② Connect a leading wire of the test light or resistant meter with self-contained power supply to one terminal of the fuse.
- ③ Connect the other lead of the test light or resistant meter with self-contained power supply to the electrical ground.
- ④ Look over the wire harness from the one approaching the fuse box. Repeat this process till it is approximately 15 cm from the test light or resistant meter with self-contained power supply.
- ⑤ When the test light turns on or resistance displays, the circuit from this part to the electrical ground is short-circuited.

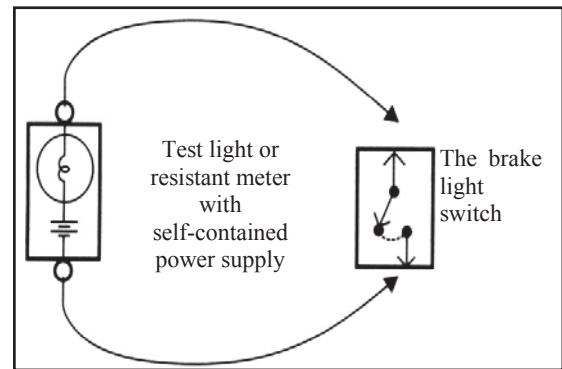
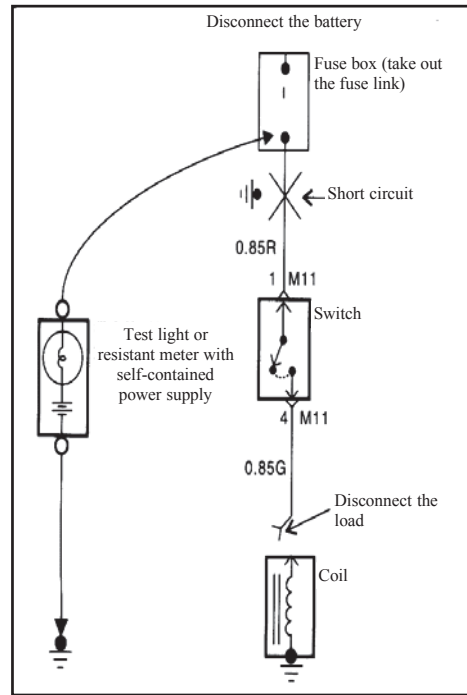

3. Power-on test

- ① Dismantle the negative terminal of the battery.
- ② Connect one lead of the test light or resistant meter with self-contained power supply to the position to be tested. When using the resistance meter, it shall short circuit the two pieces of lead and zero the meter by zero setter.
- ③ Connect the other lead of the meter to the other terminal of the load to be tested.
- ④ The light with self-contained power supply turns on, the circuit is accessible; when using the resistance meter, when the resistance value is very small and approaches to 0, it means the accessibility is favorable.

4. Check the short circuit by short-circuit detector

- ① Pull out the fused fuse wire, and dismantle the battery negative terminal.
- ② Connect the short-circuit detector to the terminal of fuse wire.
- ③ Switch on to check the circuit.
- ④ When the short-circuit detector moves to the short-circuited position, it will generate impulsive magnetic force between the fuse wire and the short-circuited position.
- ⑤ Move short-circuit detector from the fuse box along the lead gradually. As long as the short-circuit detector is between the fuse wire and short circuit, the pointer will move with the size of the pulse current. Once the detector passed the position of

Power distribution system-6

A-6

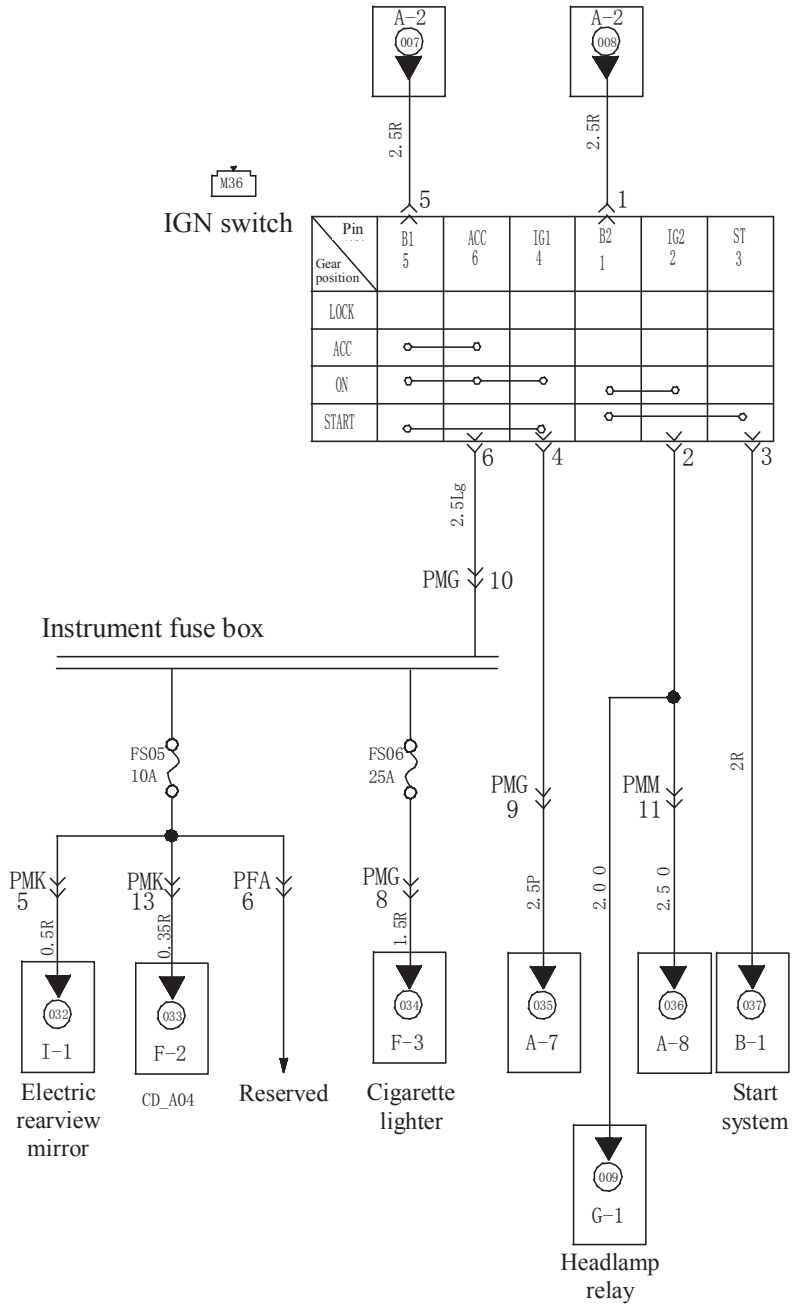

Engine ECU system-1

D-1

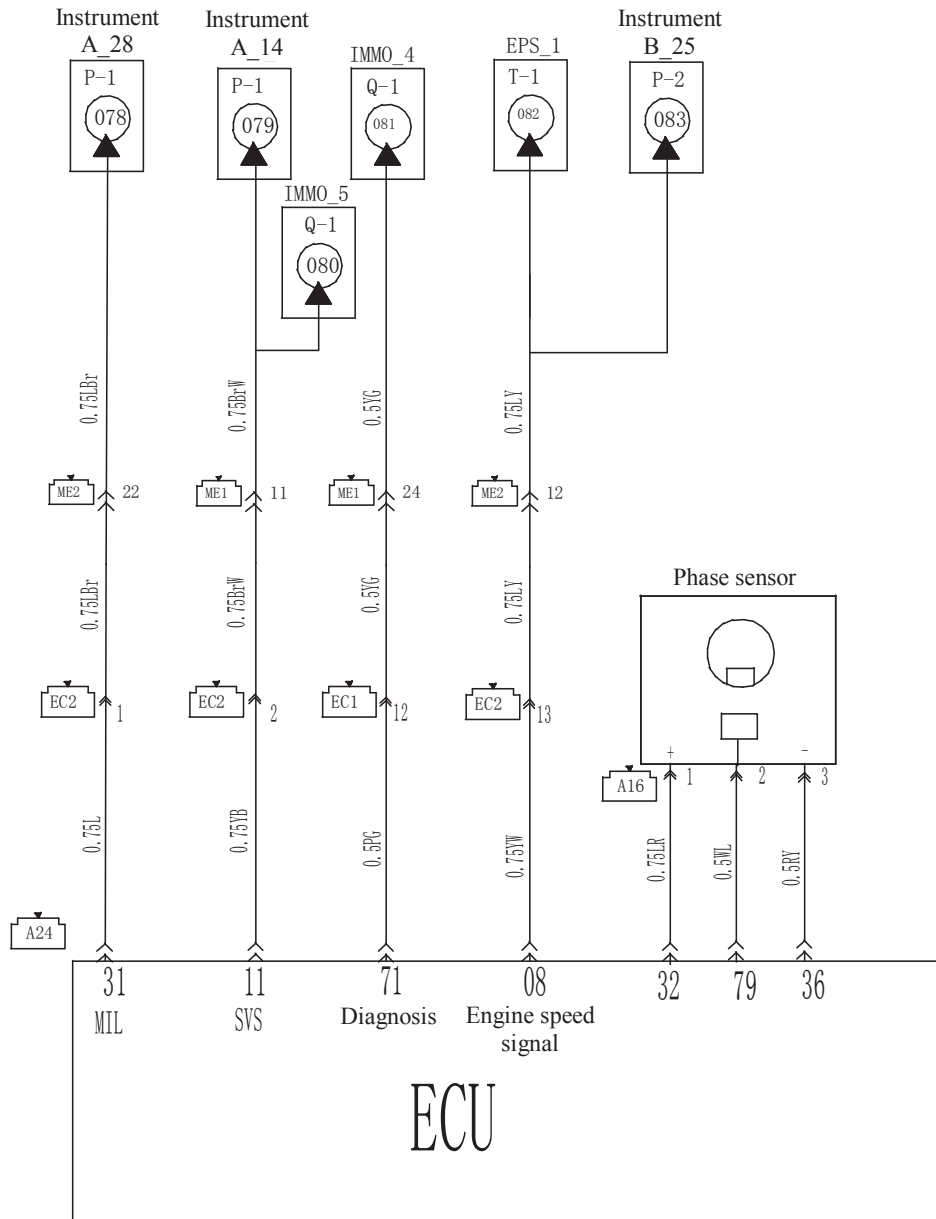

A16 Phase sensor

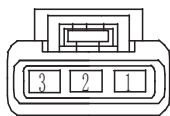

A24 ECU

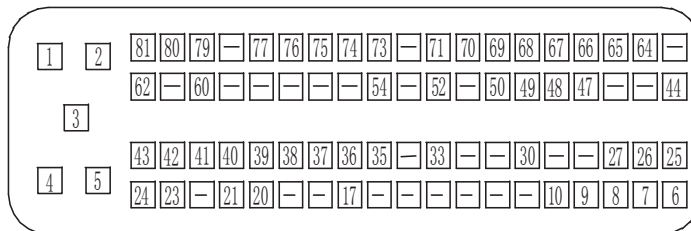

Engine ECU system-9

D-9

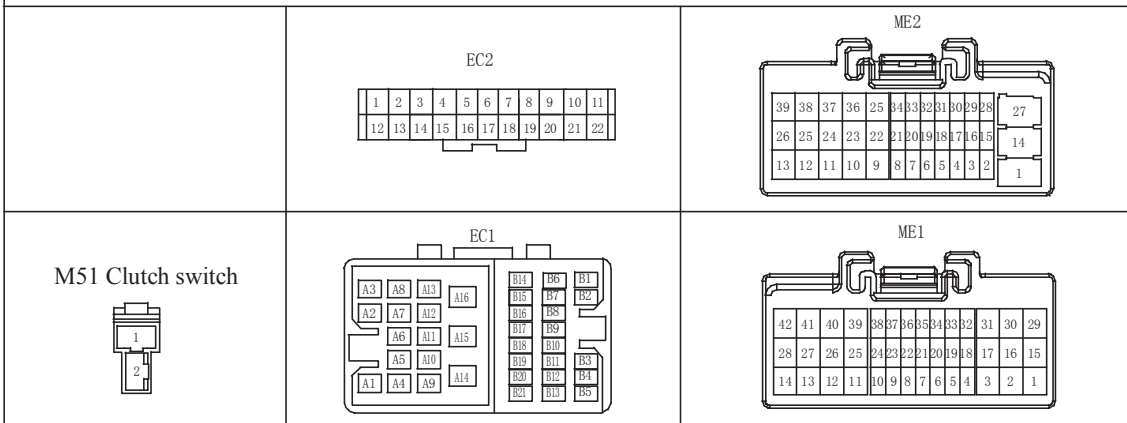
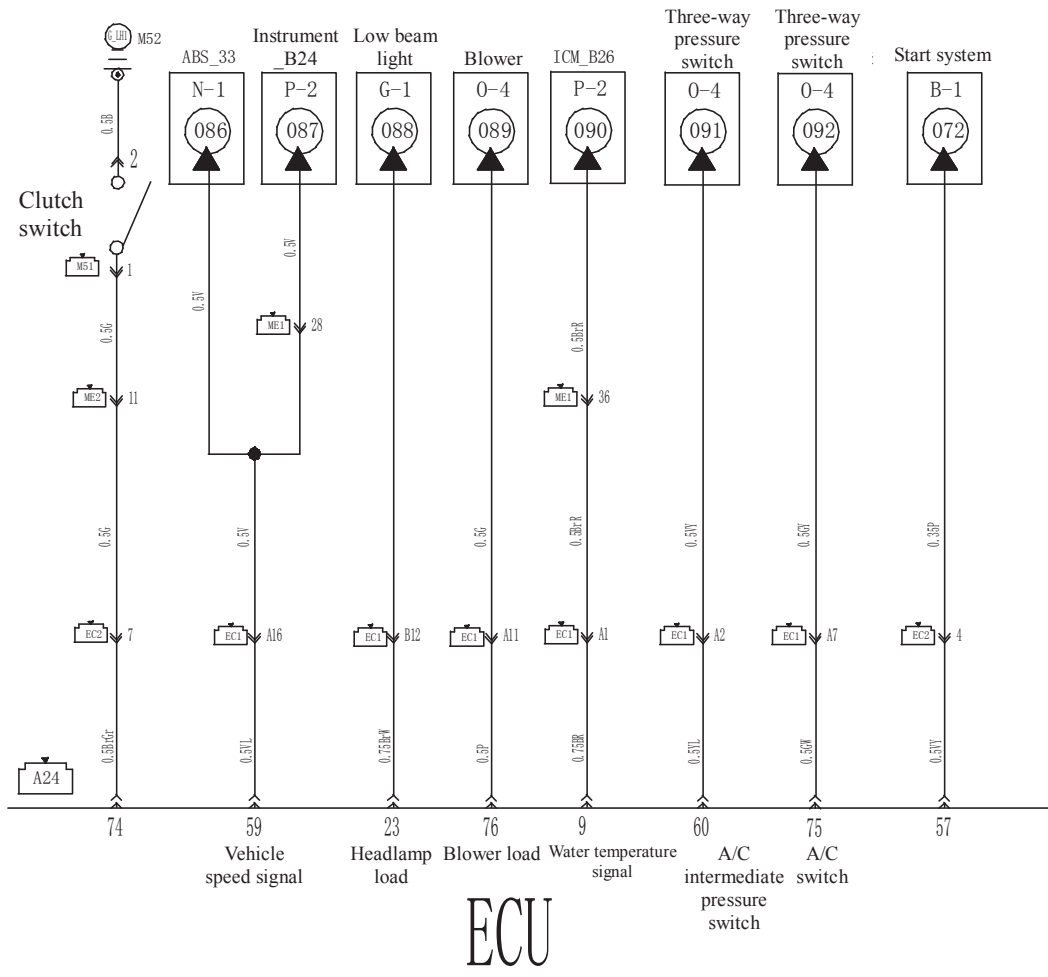

ACC system - Cigarette lighter

F-3

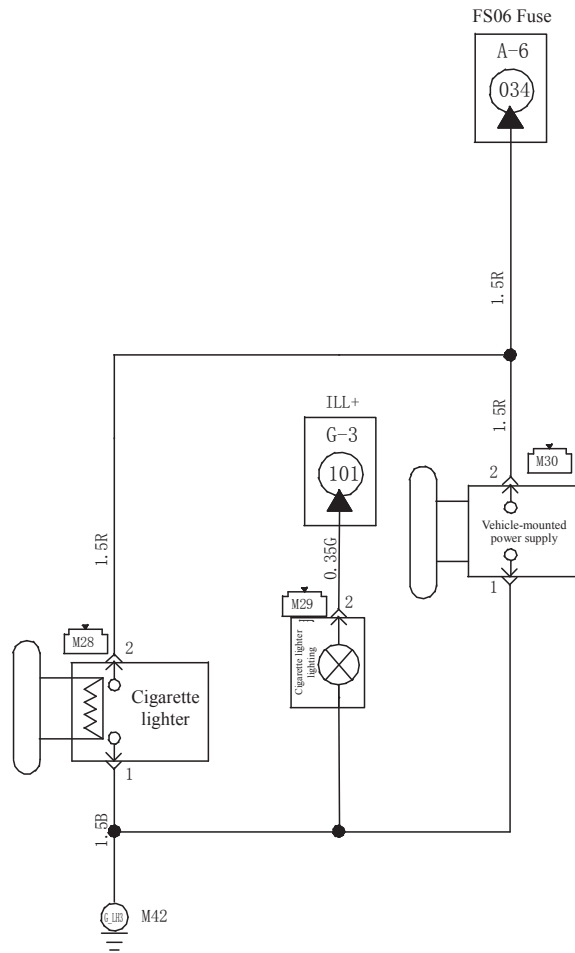

M28 Cigarette lighter



M29 Cigarette lighter lighting



M30 Vehicle-mounted power supply



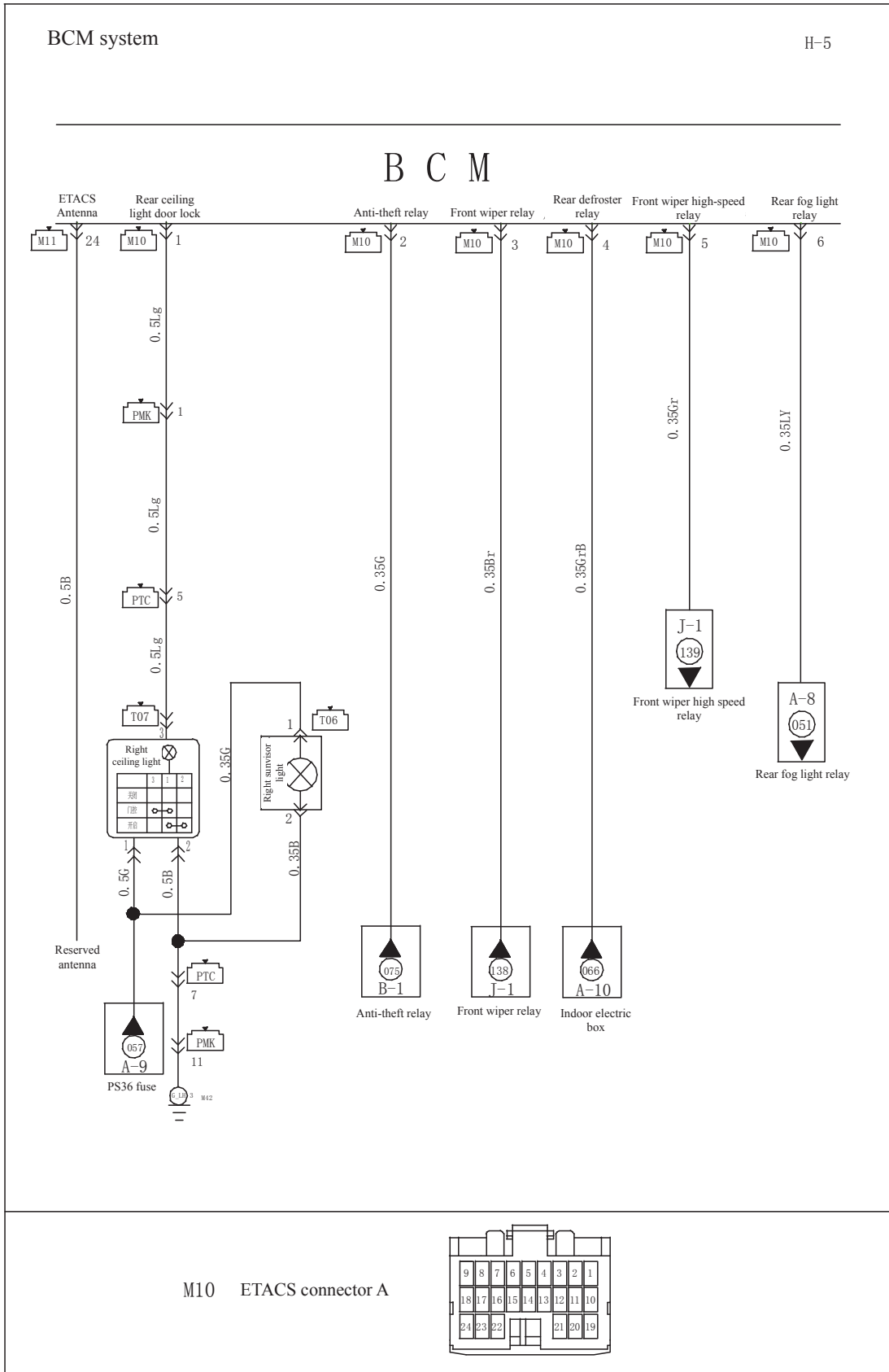

Electric rearview mirror-2		I-2
Component location index		
Component code		
M46	Electric rearview mirror switch	
D04	Left electric rearview mirror	
D14	Right electric rearview mirror	
Connector		
FD01	Harness connector of body and front left door	
FD03	Harness connector of body and front right door	
MF1	Connector 1 of main harness and body harness	
PFA	Connector A of body harness and indoor electrical box	
GND		
M52		
F04		
F36		

Auto A/C system - 1

0-1

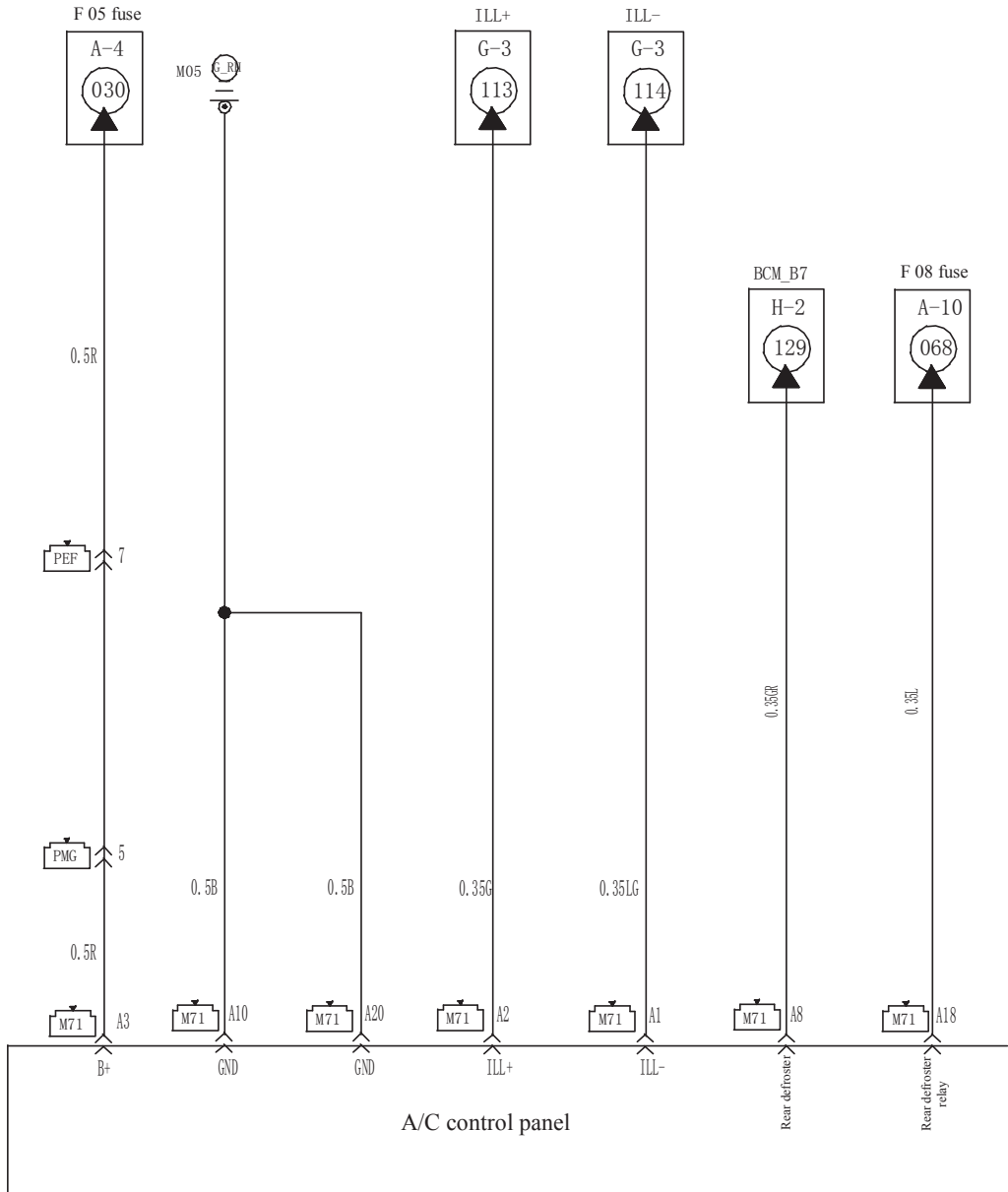

M71 A/C control panel A

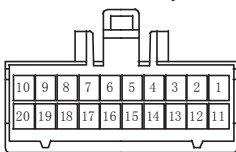

M72 A/C control panel B

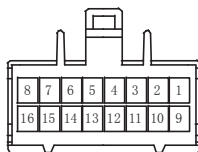

PEF

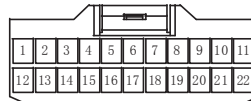

PMG

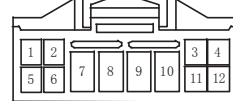

Manual A/C system - compressor

0-3

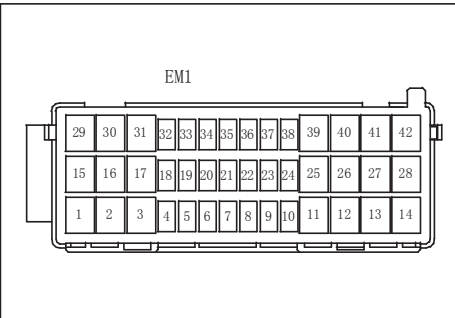
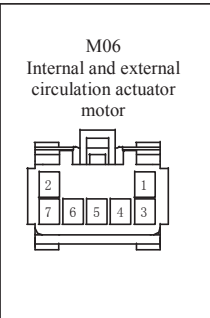
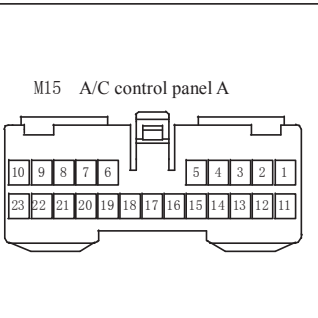
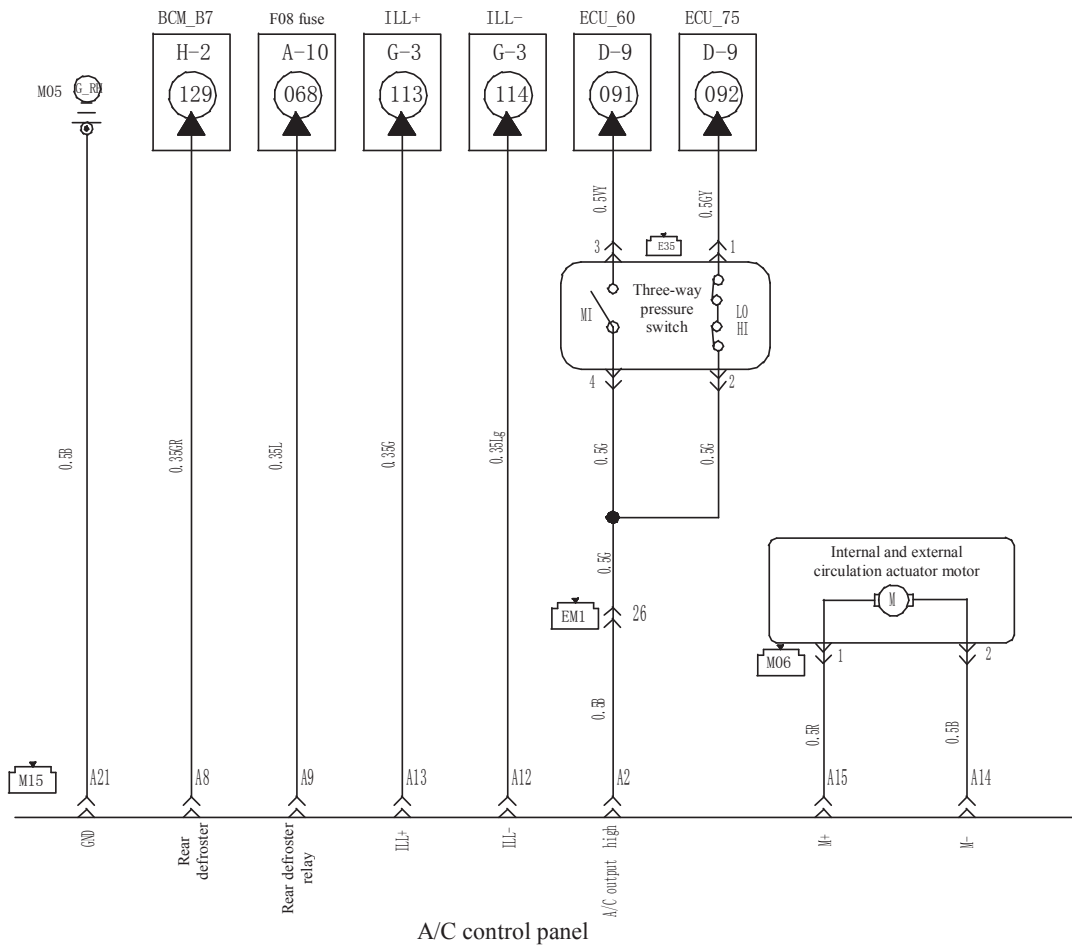

Electric glass lifting - 2

R-2

Master switch for glass lifting control

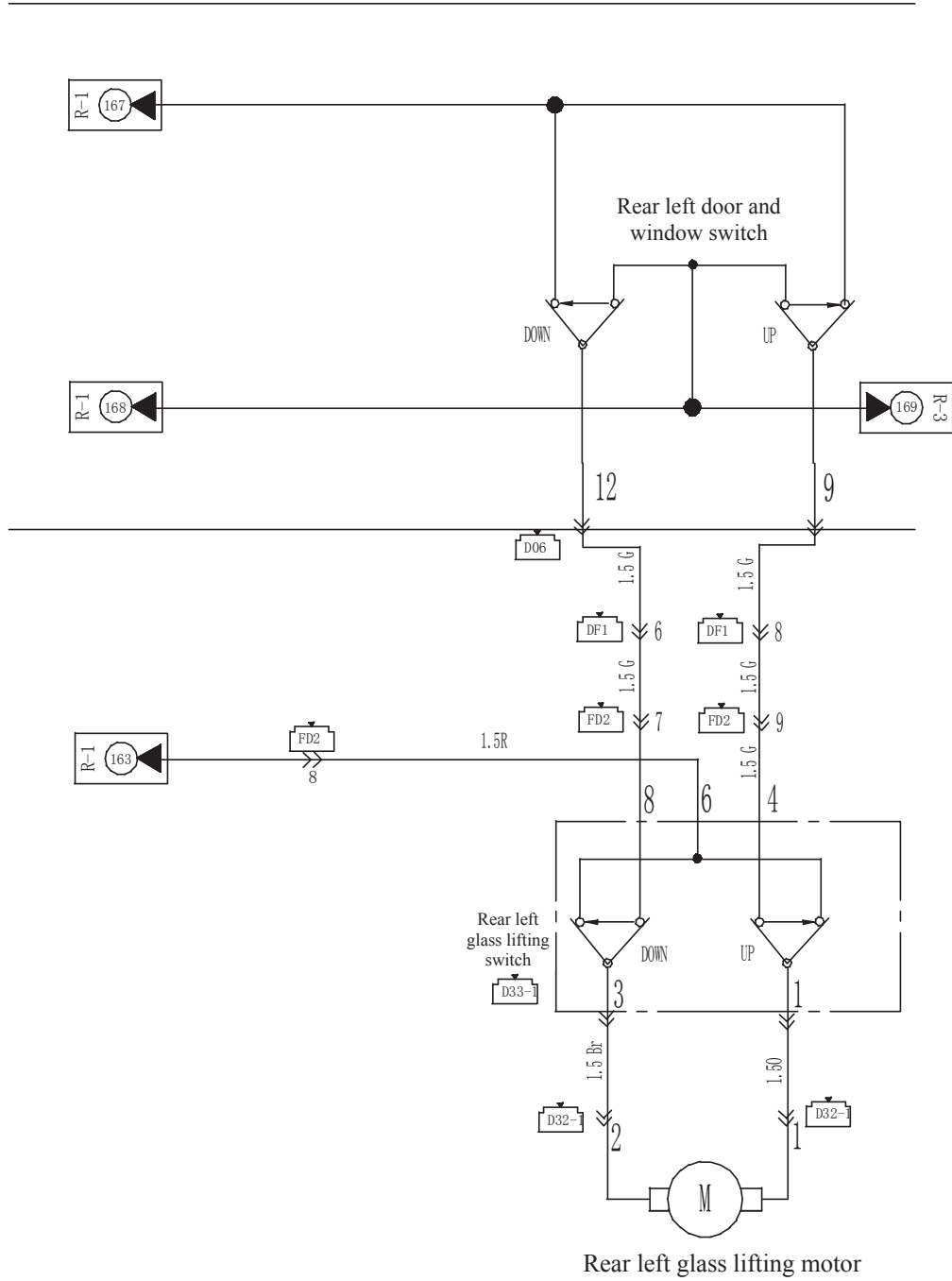

D33-1 Rear left door glass lifting switch

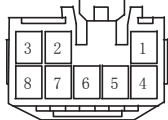

D32-1 Rear left glass lifting motor

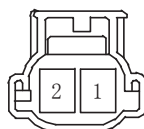

FD2

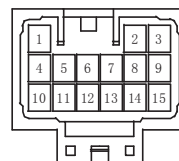

D06 Master switch for front left glass lifting control

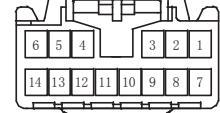

Tail door wire harness and sensor wire harness

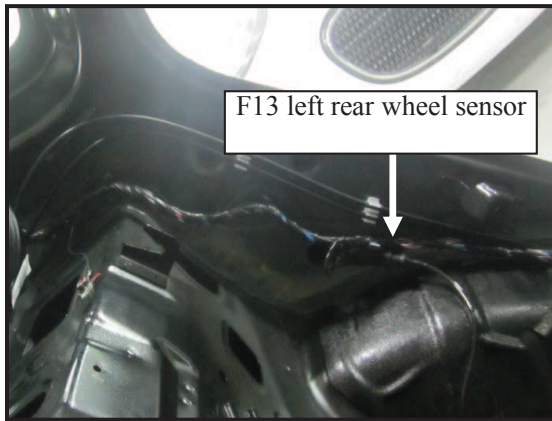

F13

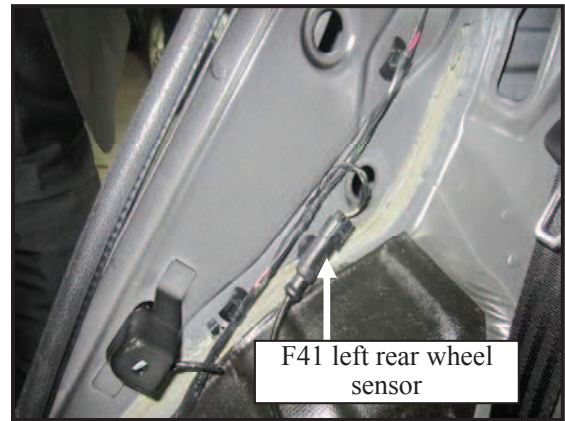

F41



F17 F18

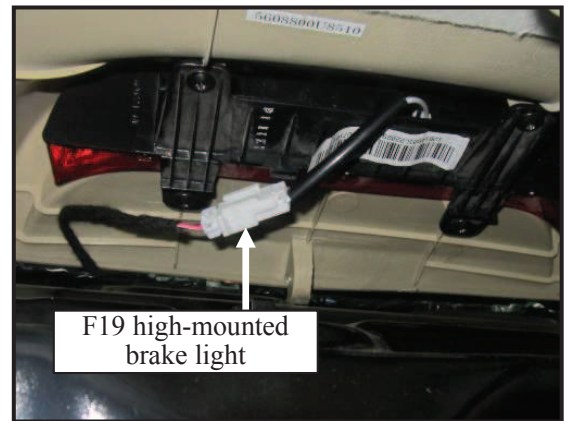

F19

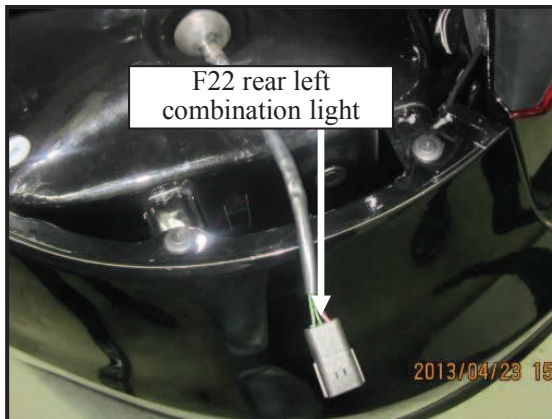

F22



F24 F27