

2002 Dodge Pickup R2500

2002 SYSTEM WIRING DIAGRAMS DODGE Pickup R2500

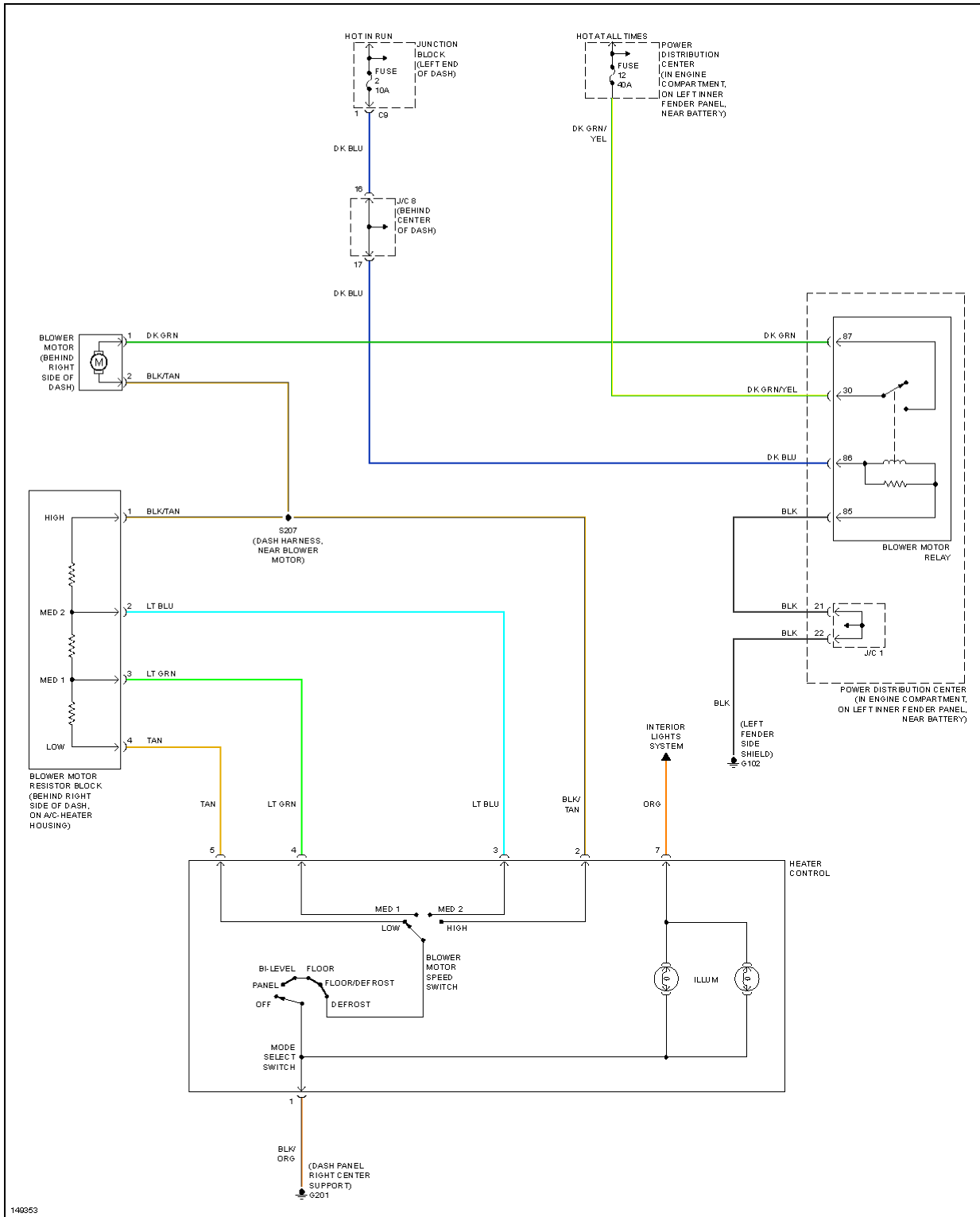

Fig. 1: Heater Circuit

2002 Dodge Pickup R2500

2002 SYSTEM WIRING DIAGRAMS DODGE Pickup R2500

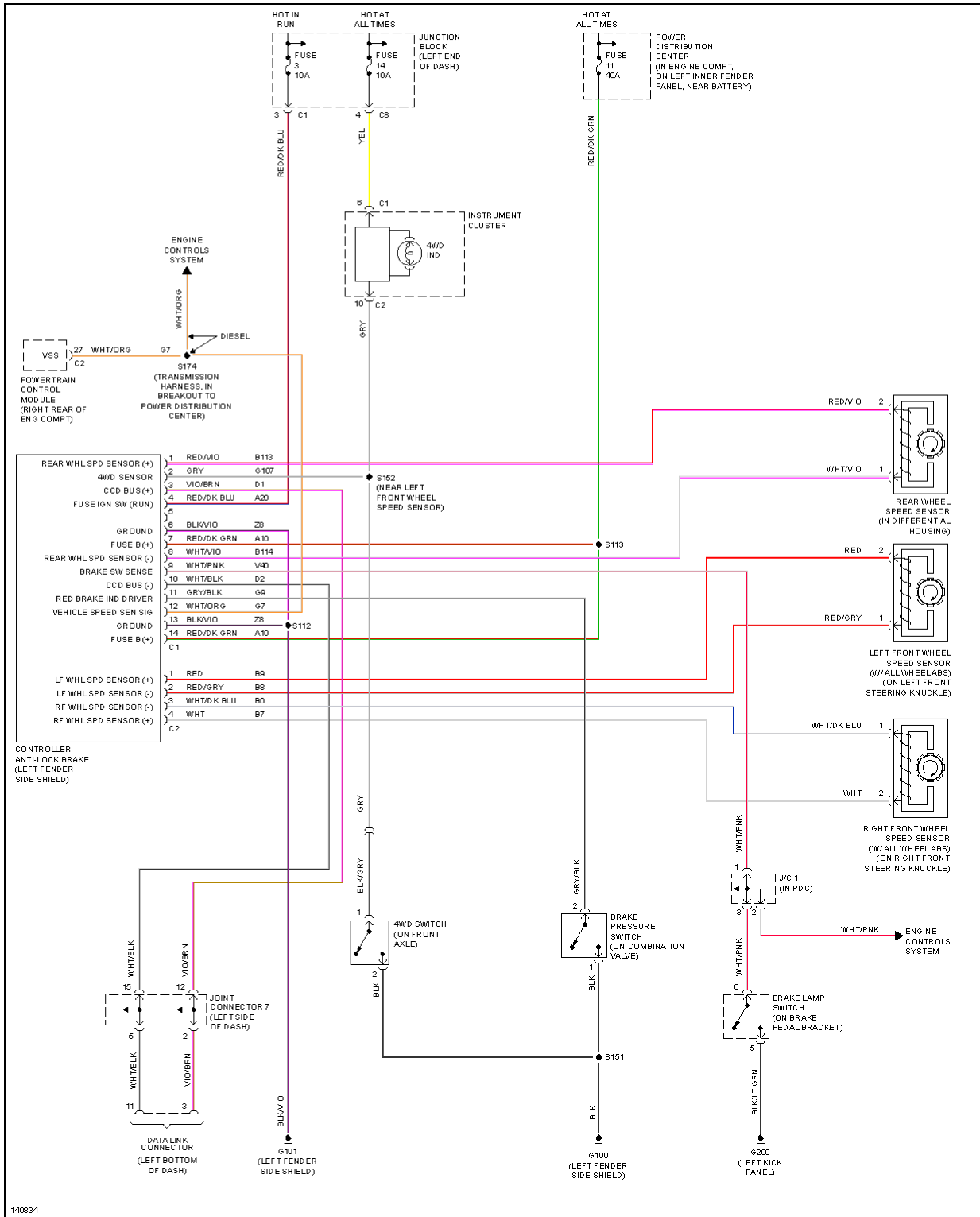

Fig. 3: Anti-lock Brake Circuits

2002 Dodge Pickup R2500

2002 SYSTEM WIRING DIAGRAMS DODGE Pickup R2500

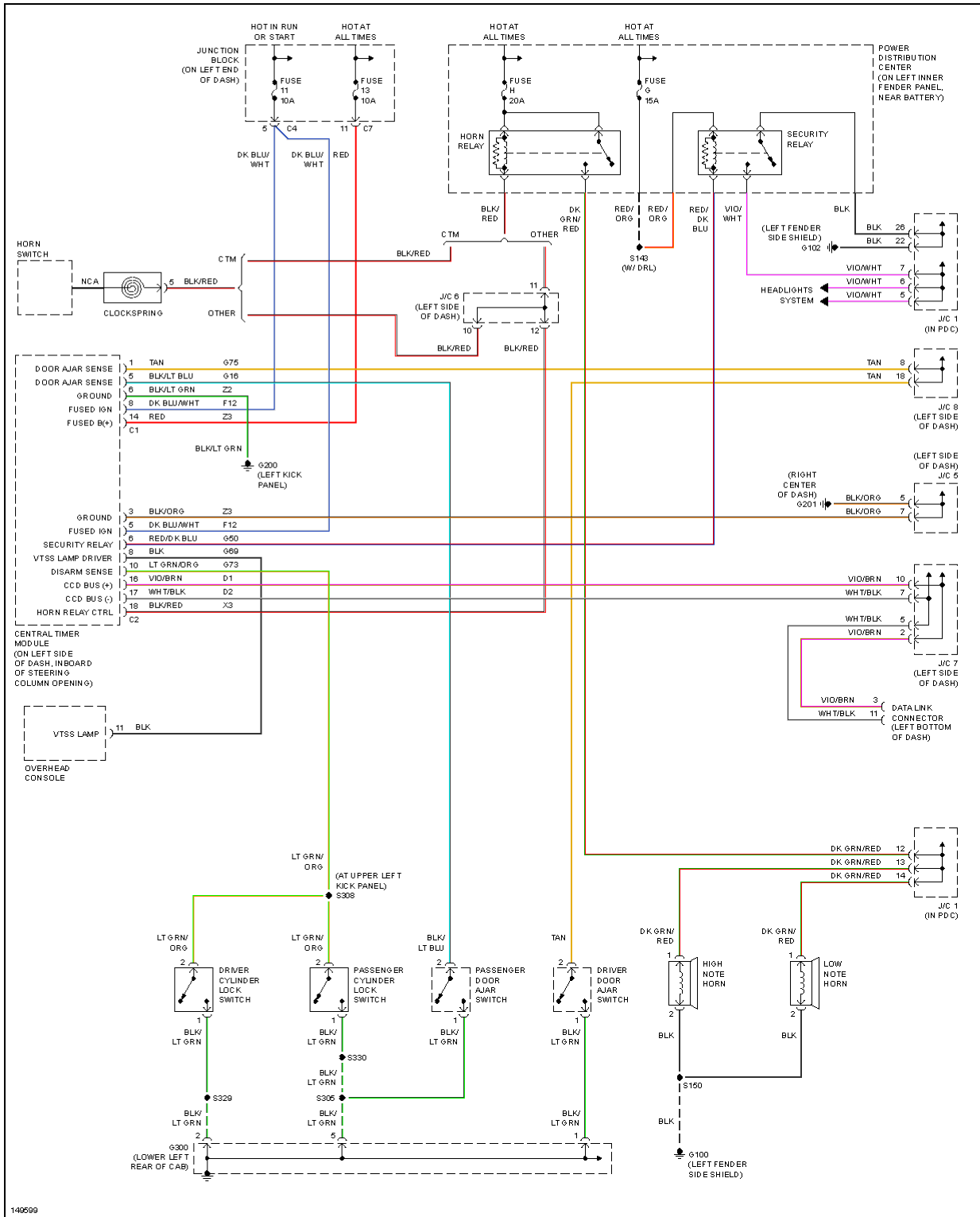

Fig. 4: Anti-theft Circuit

2002 Dodge Pickup R2500

2002 SYSTEM WIRING DIAGRAMS DODGE Pickup R2500

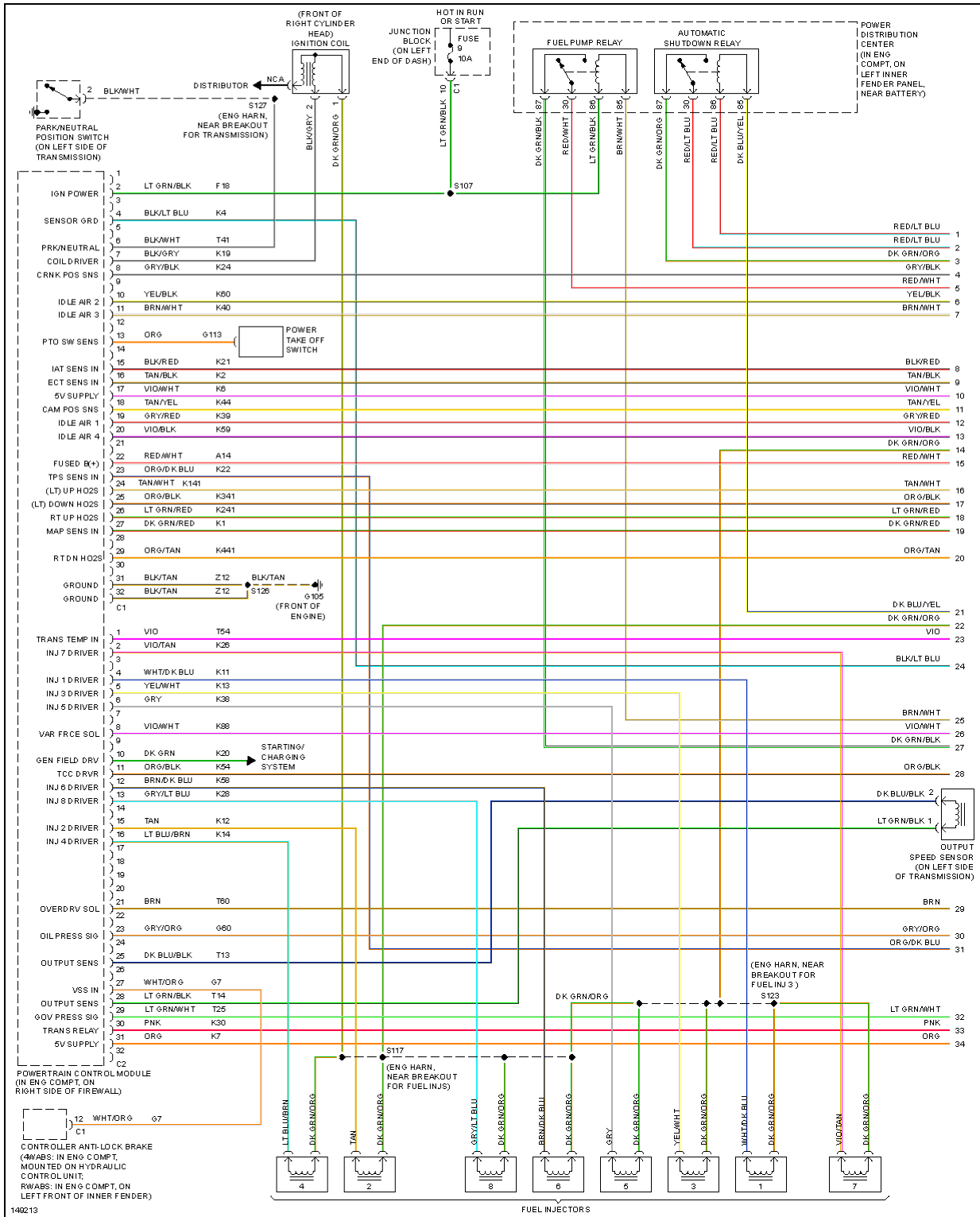

Fig. 12: 5.9L, Engine Performance Circuits, California (1 of 4)

2002 Dodge Pickup R2500

2002 SYSTEM WIRING DIAGRAMS DODGE Pickup R2500

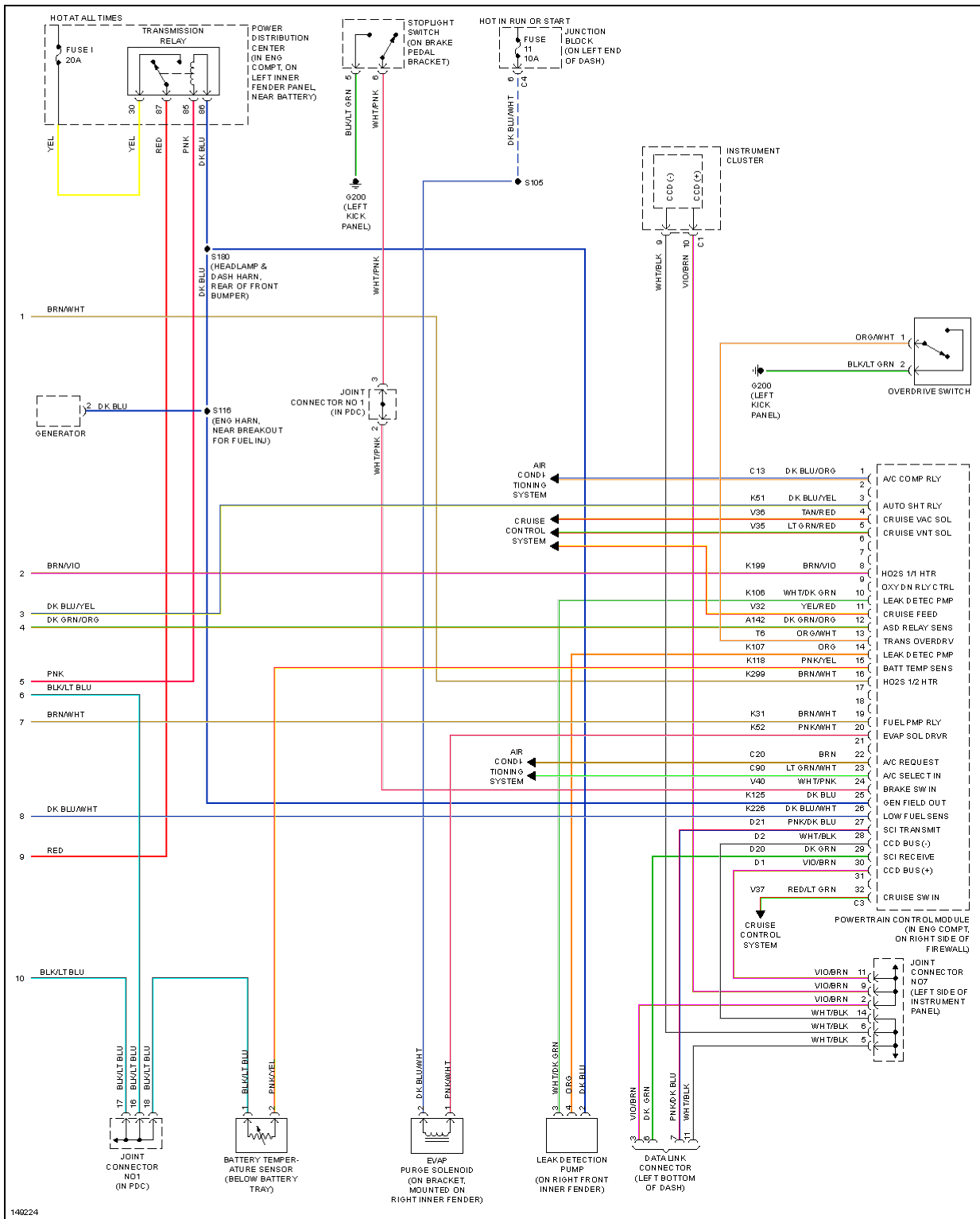

Fig. 19: 5.9L, Engine Performance Circuits, Federal (4 of 4)

2002 Dodge Pickup R2500

2002 SYSTEM WIRING DIAGRAMS DODGE Pickup R2500

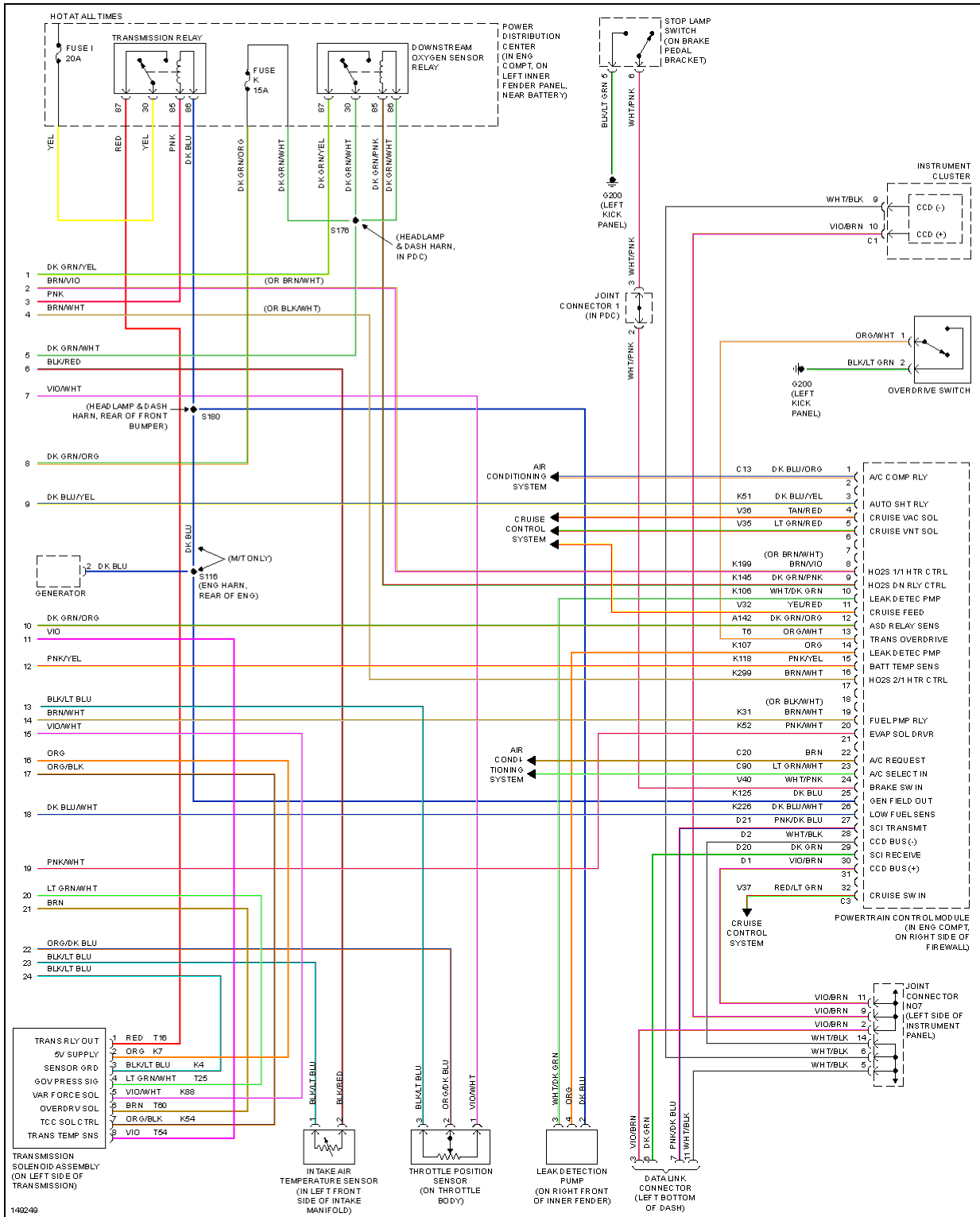

Fig. 26: 8.0L, Engine Performance Circuits (3 of 3)

2002 Dodge Pickup R2500

2002 SYSTEM WIRING DIAGRAMS DODGE Pickup R2500

GROUND DISTRIBUTION

2002 Dodge Pickup R2500

2002 SYSTEM WIRING DIAGRAMS DODGE Pickup R2500

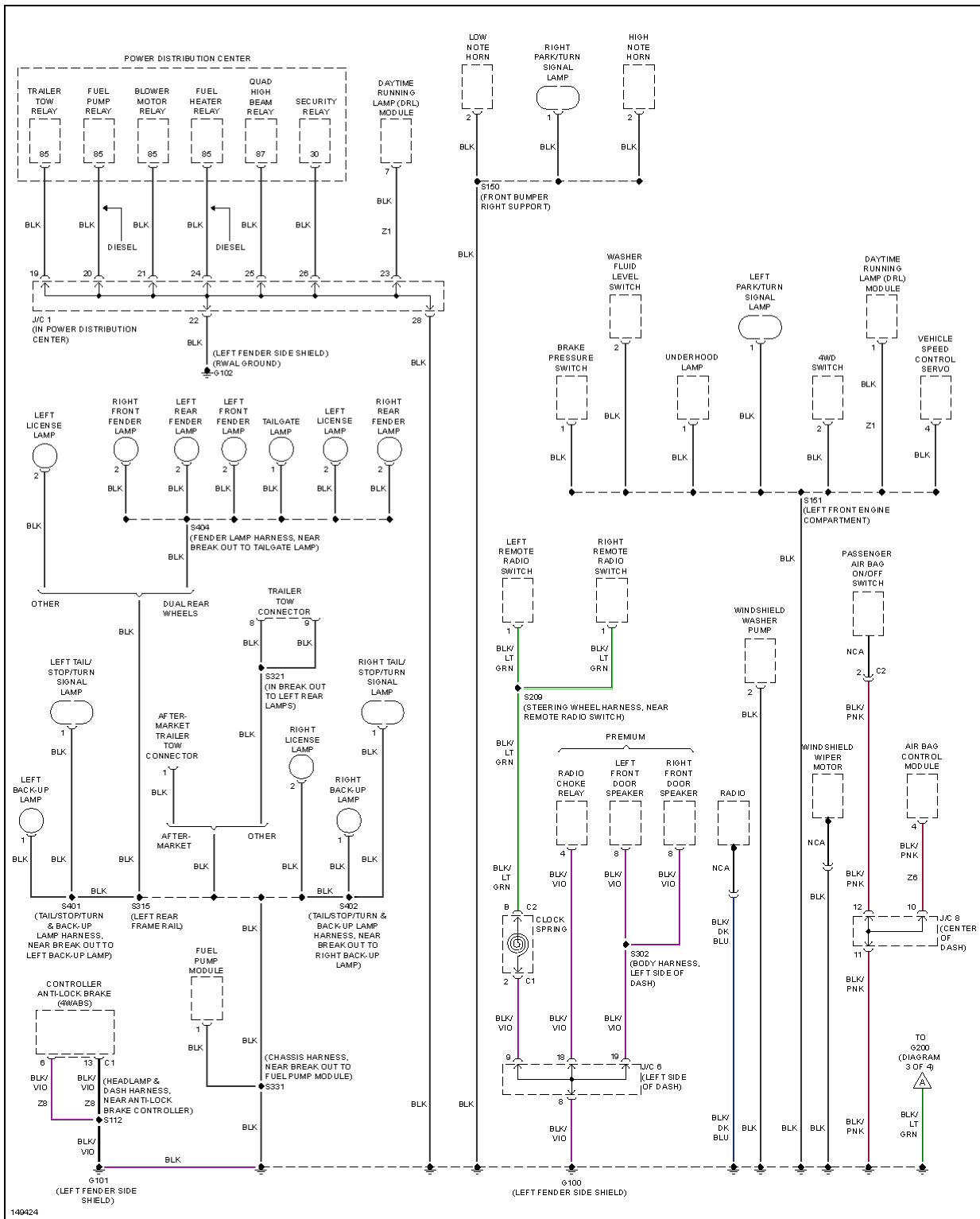

Fig. 31: Ground Distribution Circuit (2 of 4)

2002 Dodge Pickup R2500

2002 SYSTEM WIRING DIAGRAMS DODGE Pickup R2500

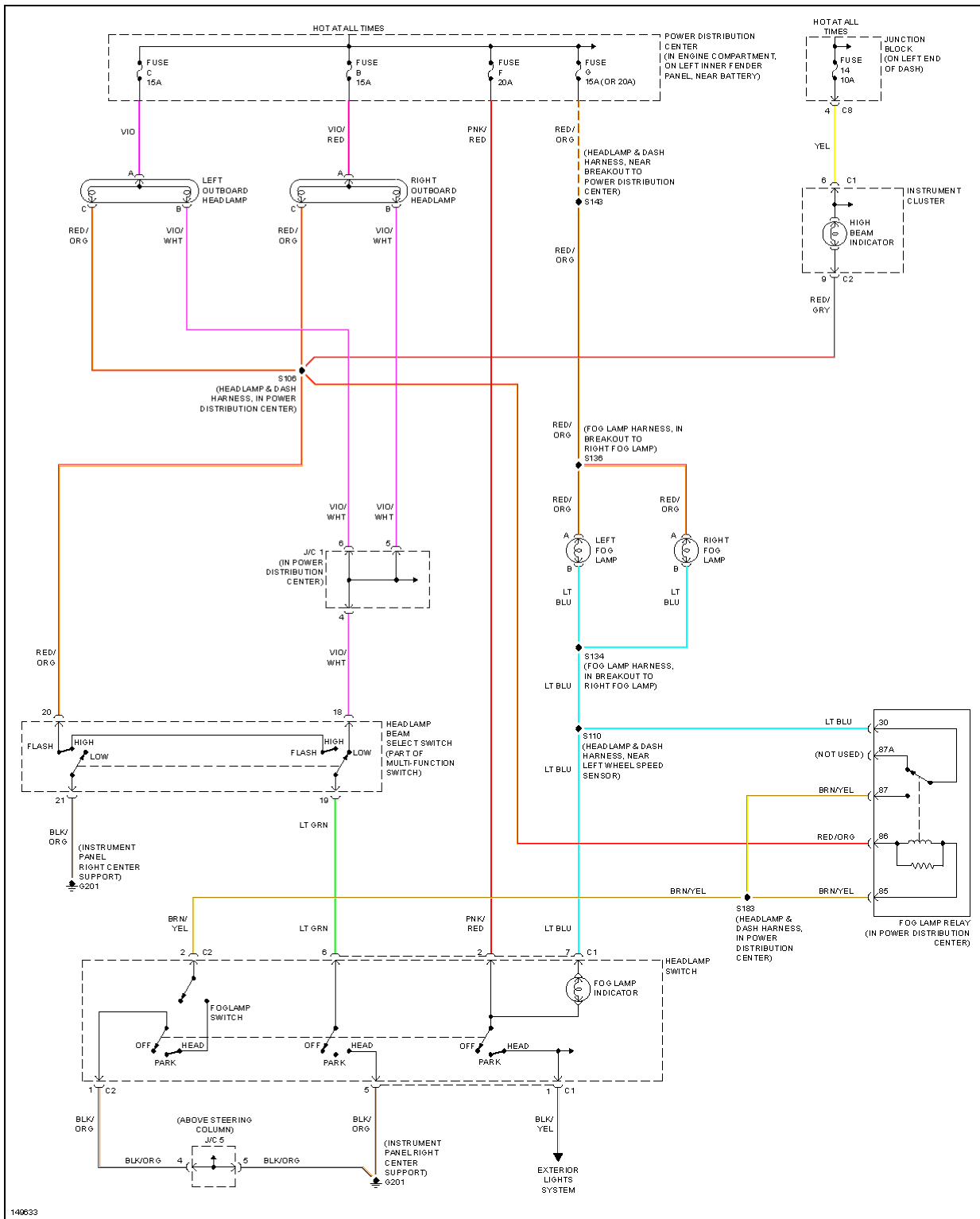

Fig. 37: Headlight Circuit, W/O DRL & W/O Quad Headlights

POWER DOOR LOCKS

2002 Dodge Pickup R2500

2002 SYSTEM WIRING DIAGRAMS DODGE Pickup R2500

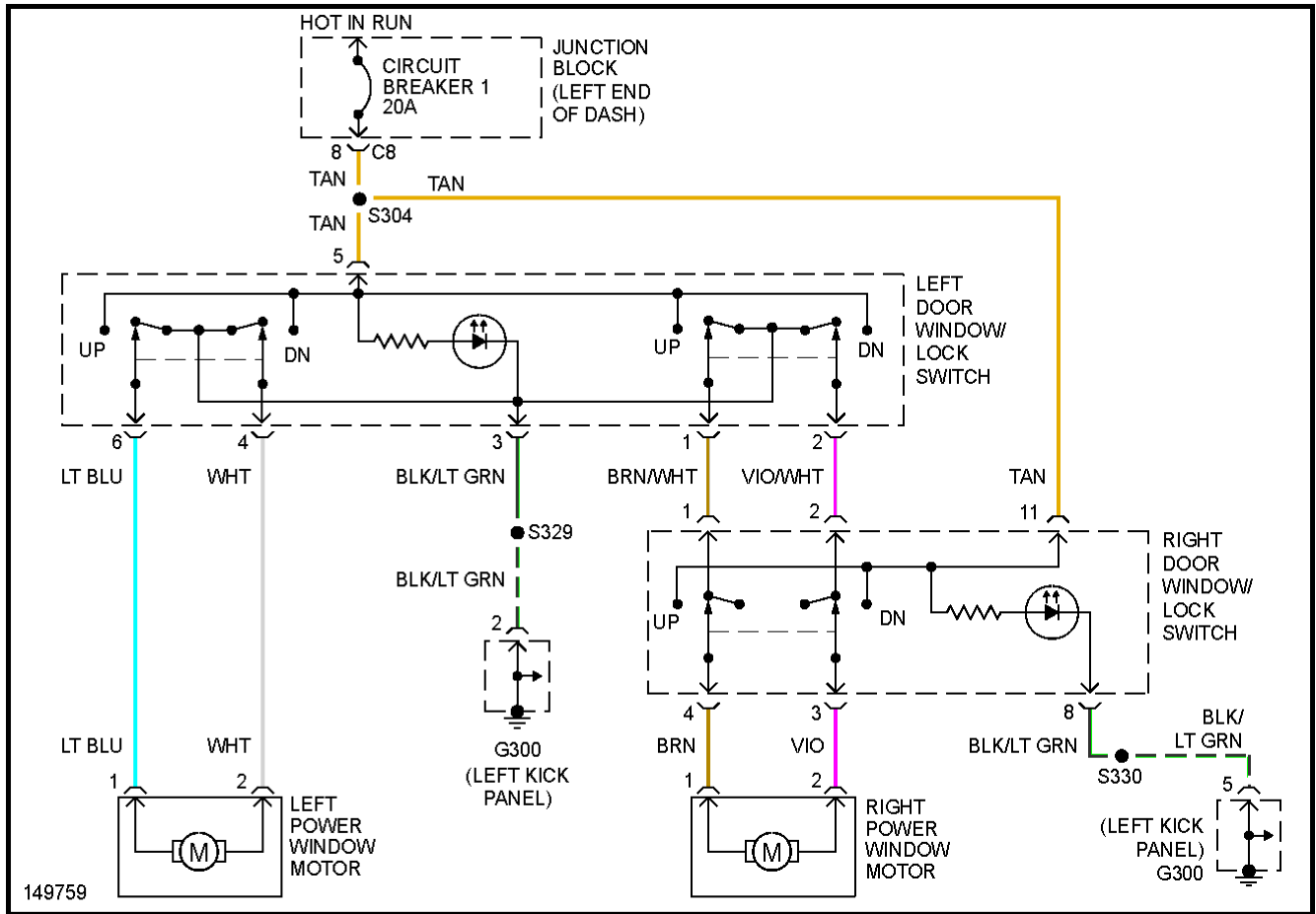

Fig. 53: Power Window Circuit

2002 Dodge Pickup R2500

2002 SYSTEM WIRING DIAGRAMS DODGE Pickup R2500

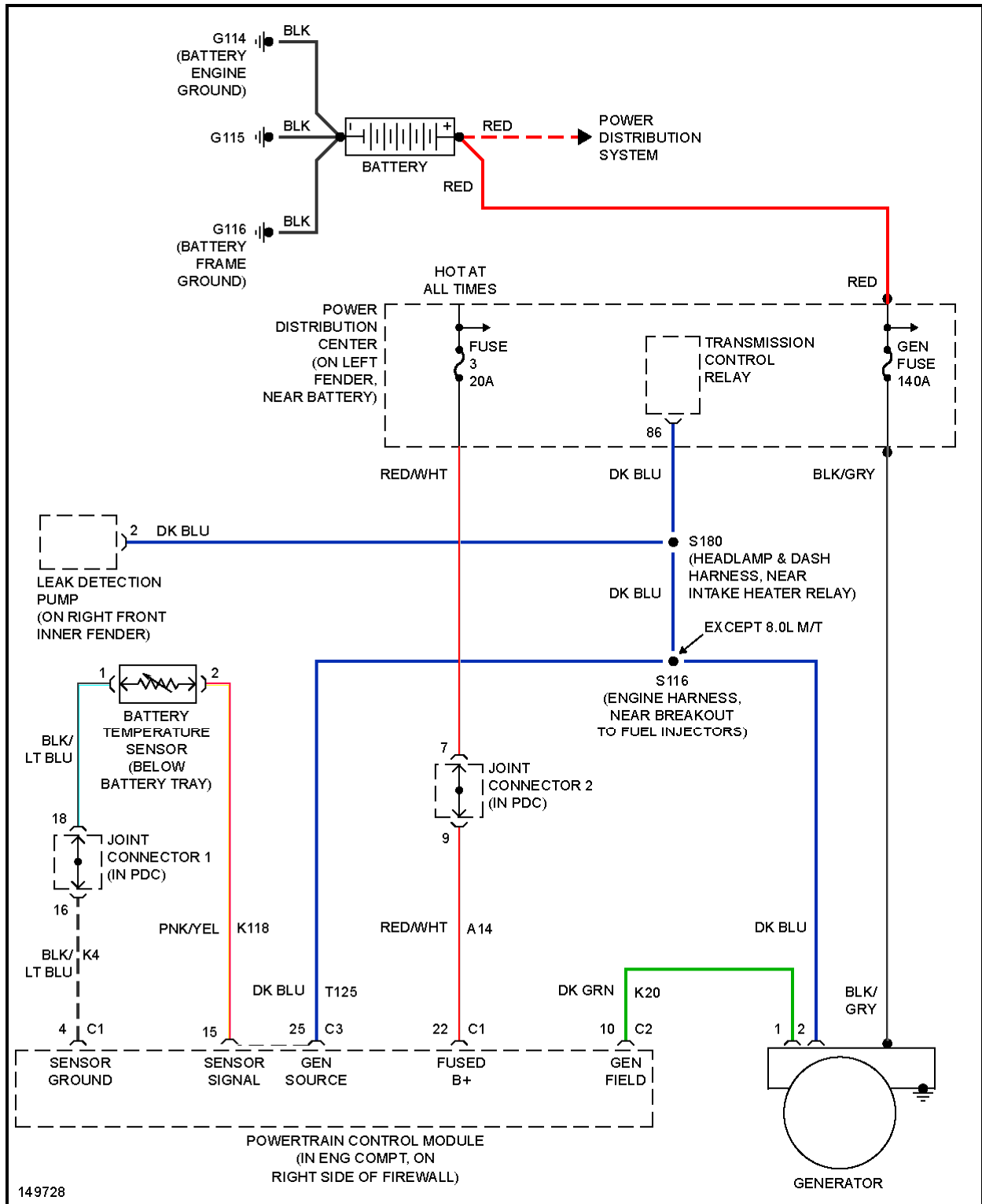

Fig. 60: 8.0L, Charging Circuit

2002 Dodge Pickup R2500

2002 SYSTEM WIRING DIAGRAMS DODGE Pickup R2500

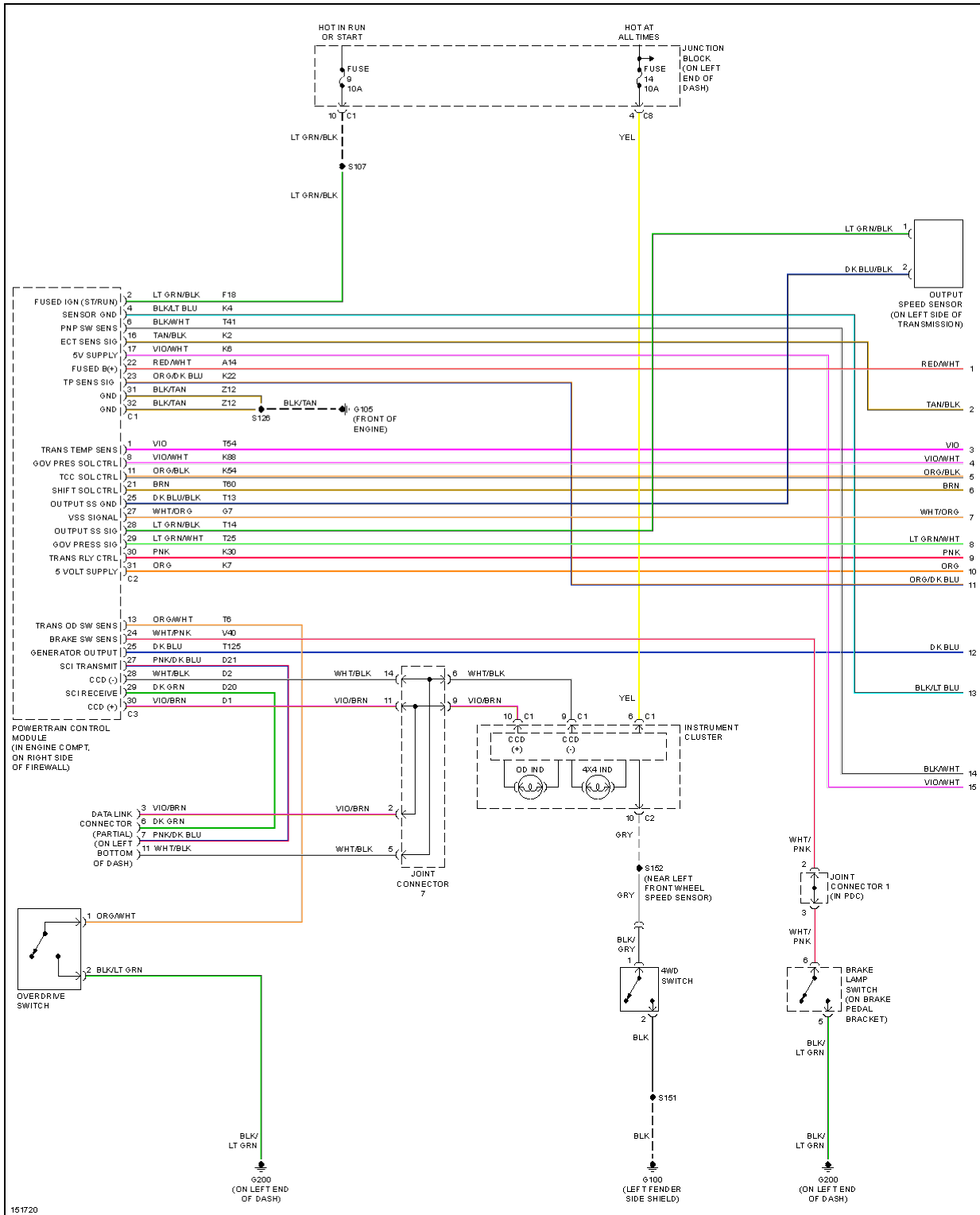

Fig. 65: 5.9L, A/T Circuit (1 of 2)