

2005 Chevrolet Uplander

2005 SYSTEM WIRING DIAGRAMS Chevrolet - Uplander

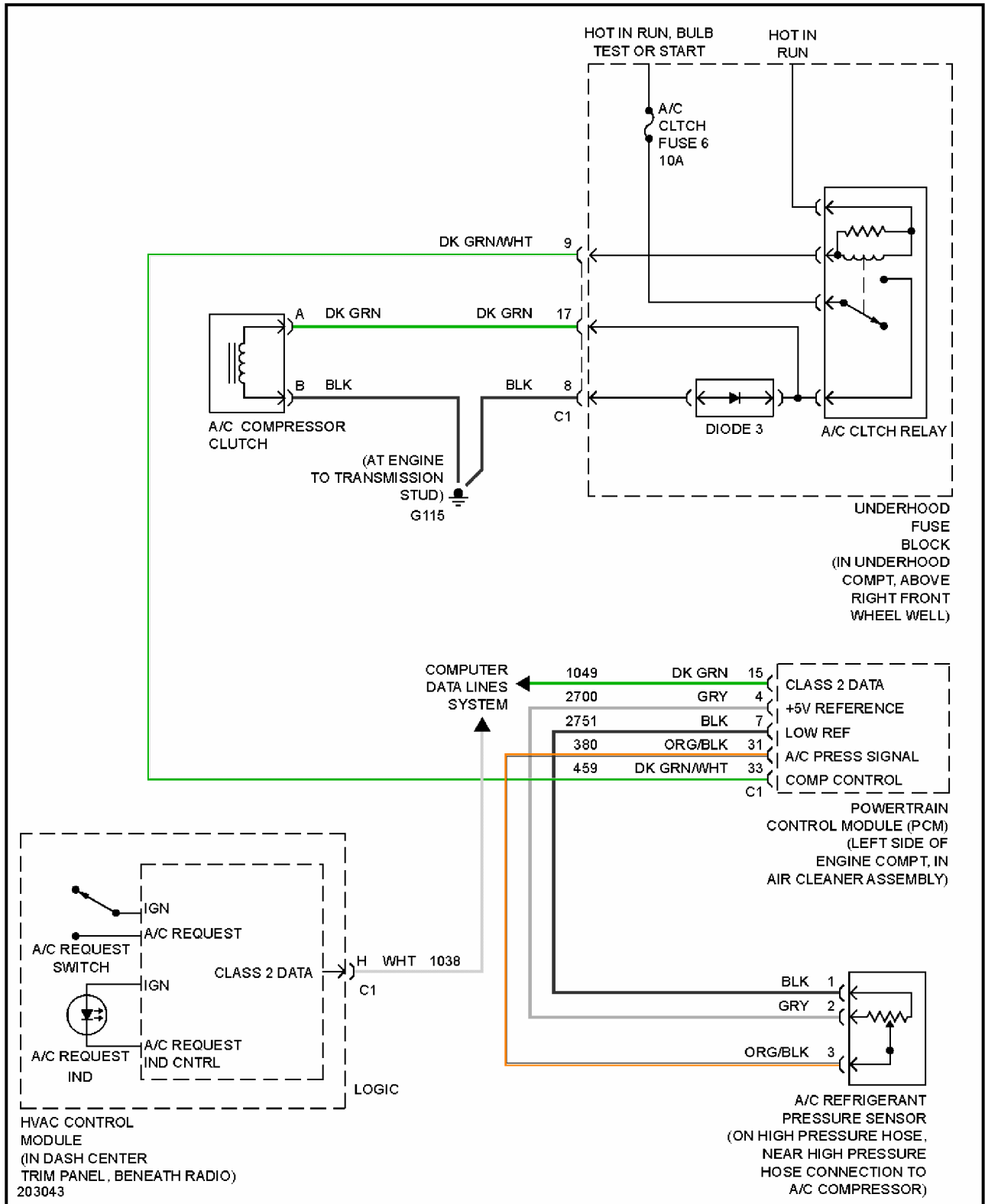

Fig. 1: Compressor Circuit

2005 Chevrolet Uplander

2005 SYSTEM WIRING DIAGRAMS Chevrolet - Uplander

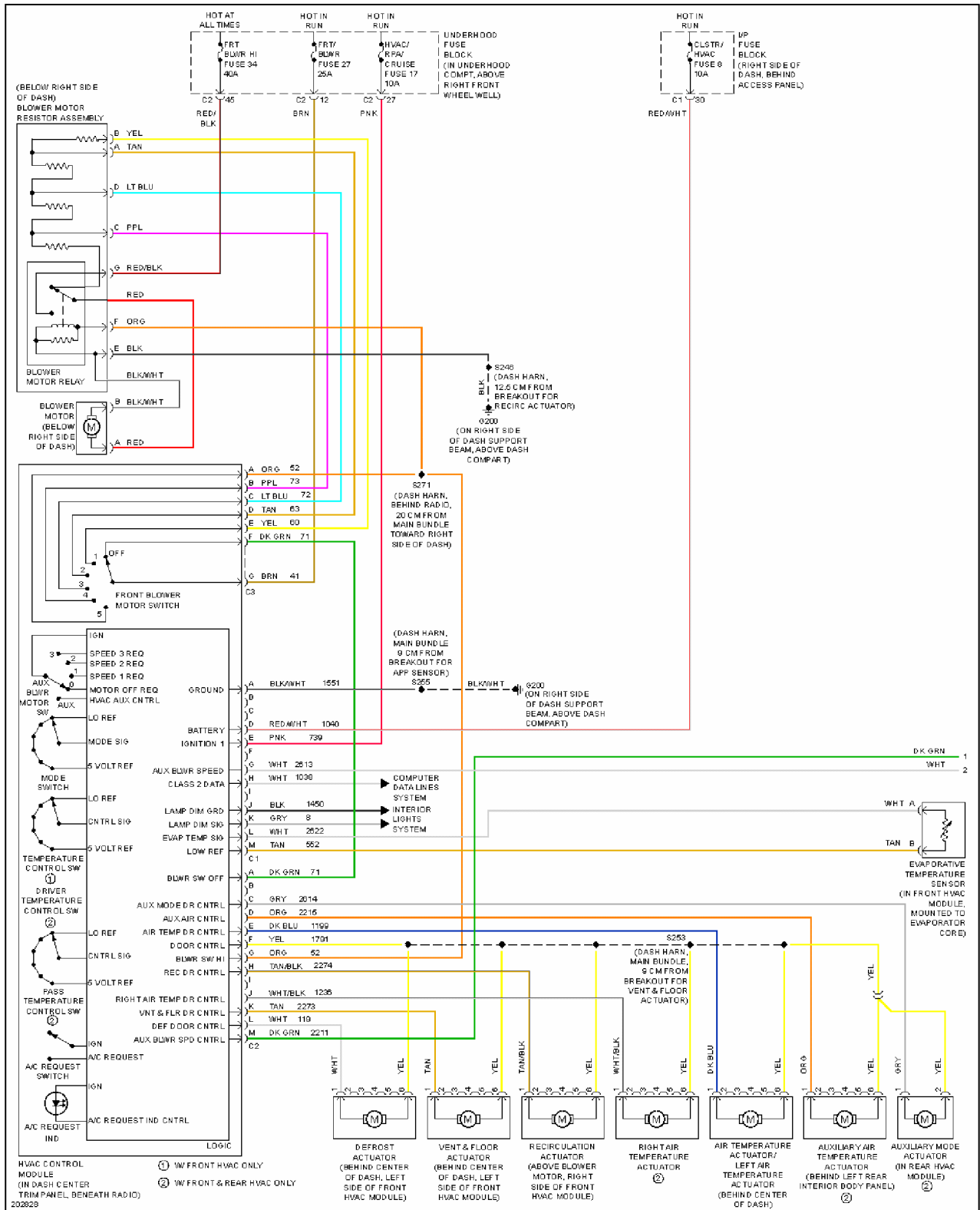

Fig. 2: Manual A/C Circuit (1 of 2)

2005 Chevrolet Uplander

2005 SYSTEM WIRING DIAGRAMS Chevrolet - Uplander

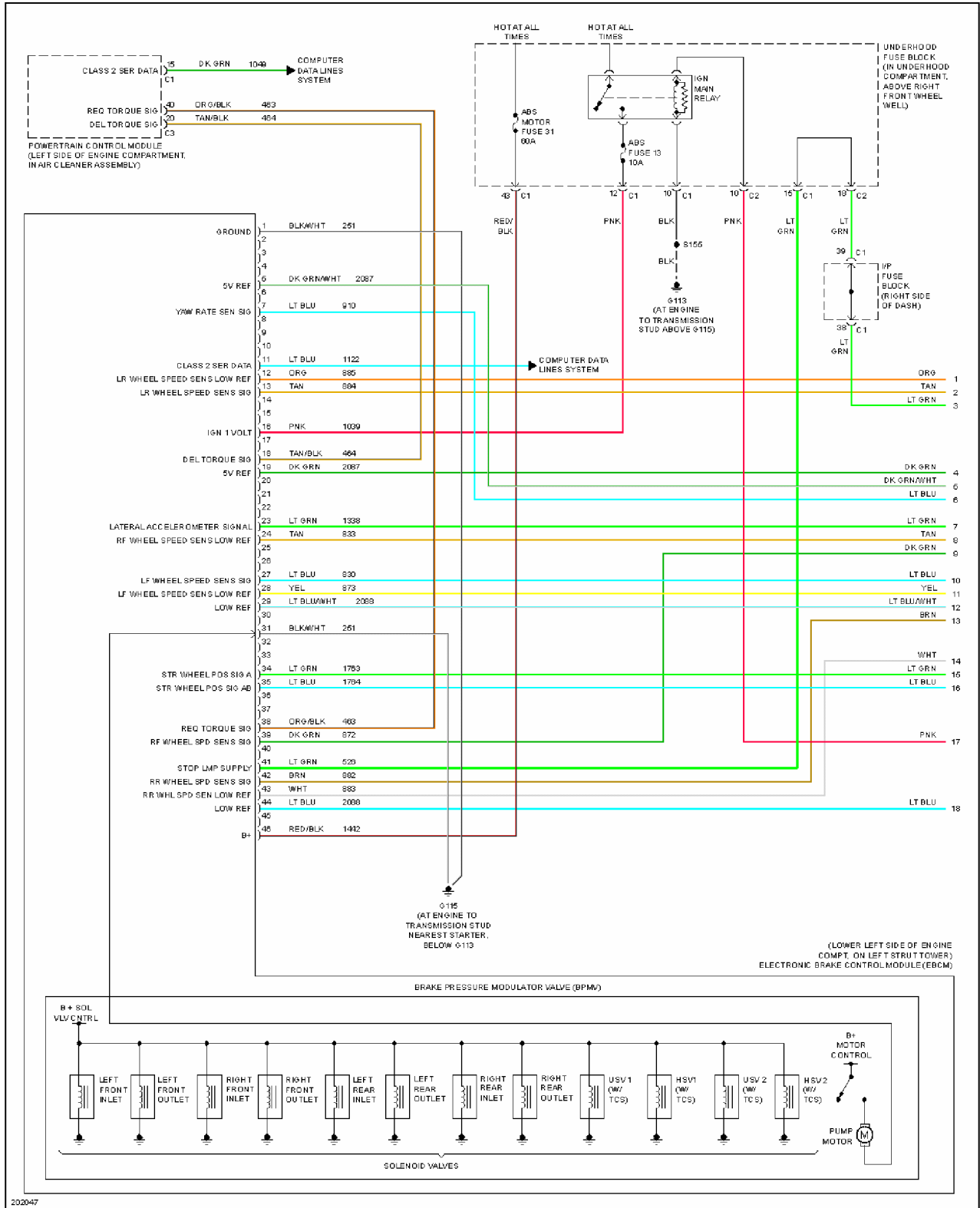

Fig. 4: Anti-lock Brakes Circuit (1 of 2)

2005 Chevrolet Uplander

2005 SYSTEM WIRING DIAGRAMS Chevrolet - Uplander

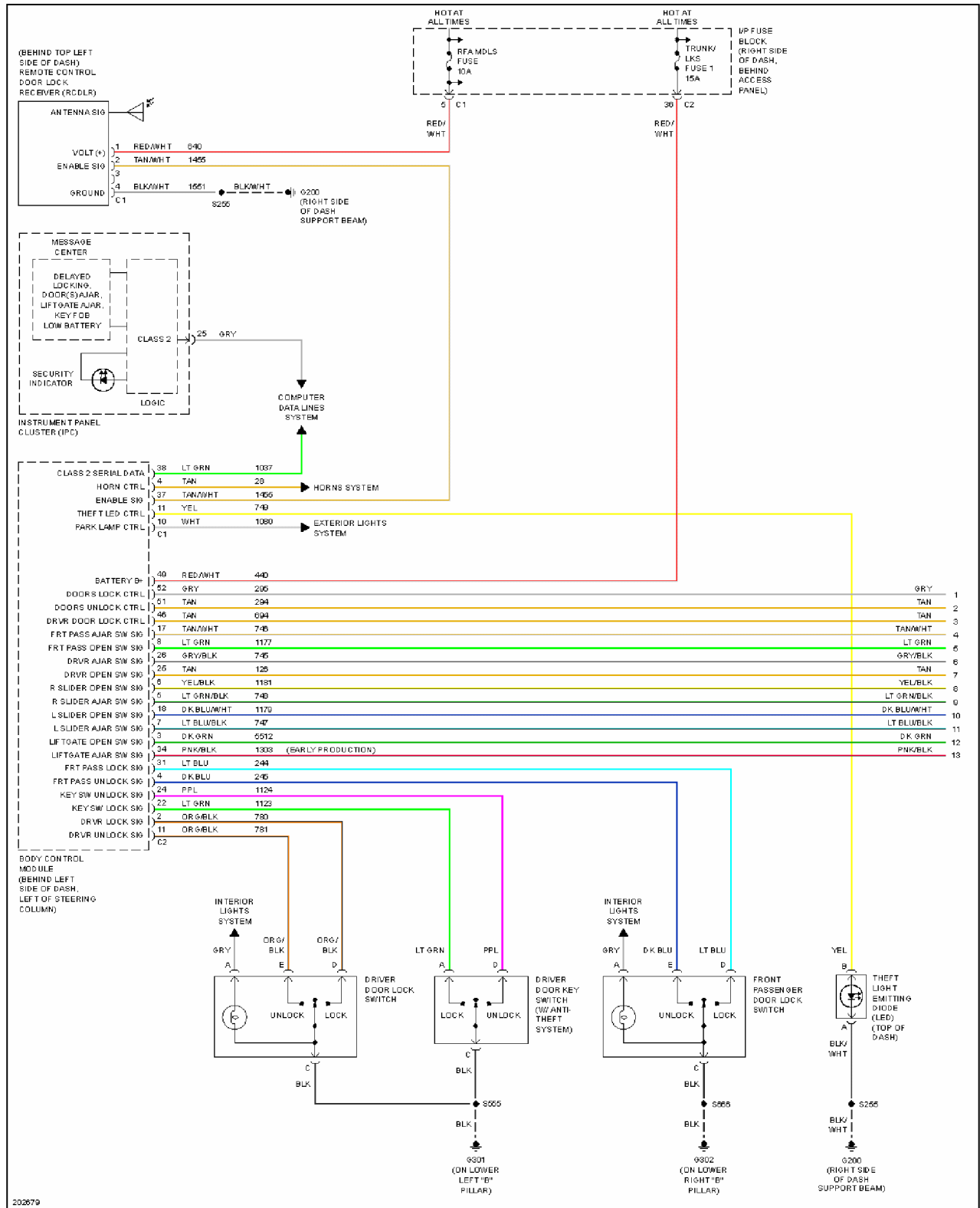

Fig. 6: Forced Entry Circuit (1 of 2)

2005 Chevrolet Uplander

2005 SYSTEM WIRING DIAGRAMS Chevrolet - Uplander

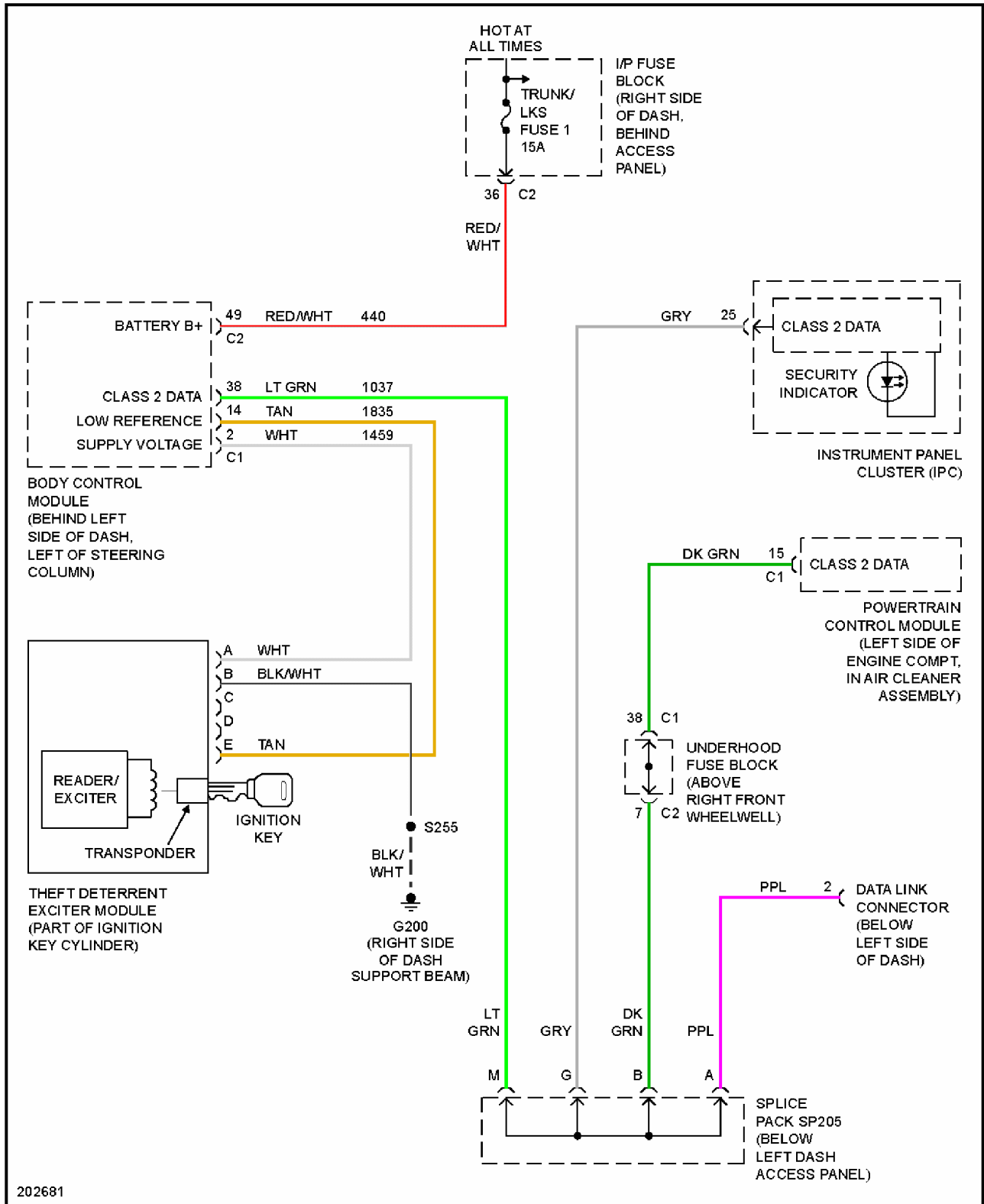

Fig. 8: Pass-Key Circuit

BODY CONTROL MODULES

2005 Chevrolet Uplander

2005 SYSTEM WIRING DIAGRAMS Chevrolet - Uplander

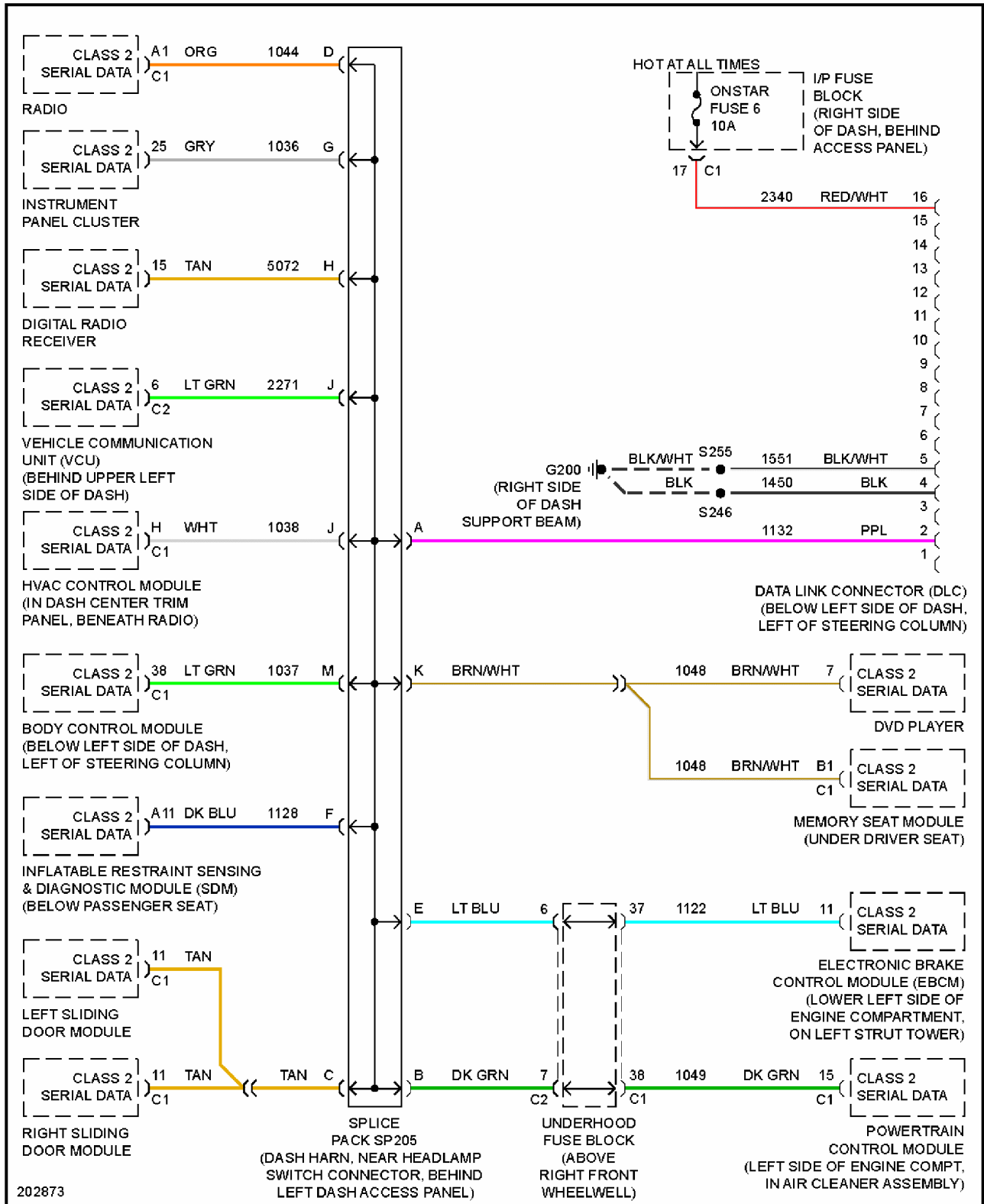

Fig. 10: Computer Data Lines Circuit

COOLING FAN

2005 Chevrolet Uplander

2005 SYSTEM WIRING DIAGRAMS Chevrolet - Uplander

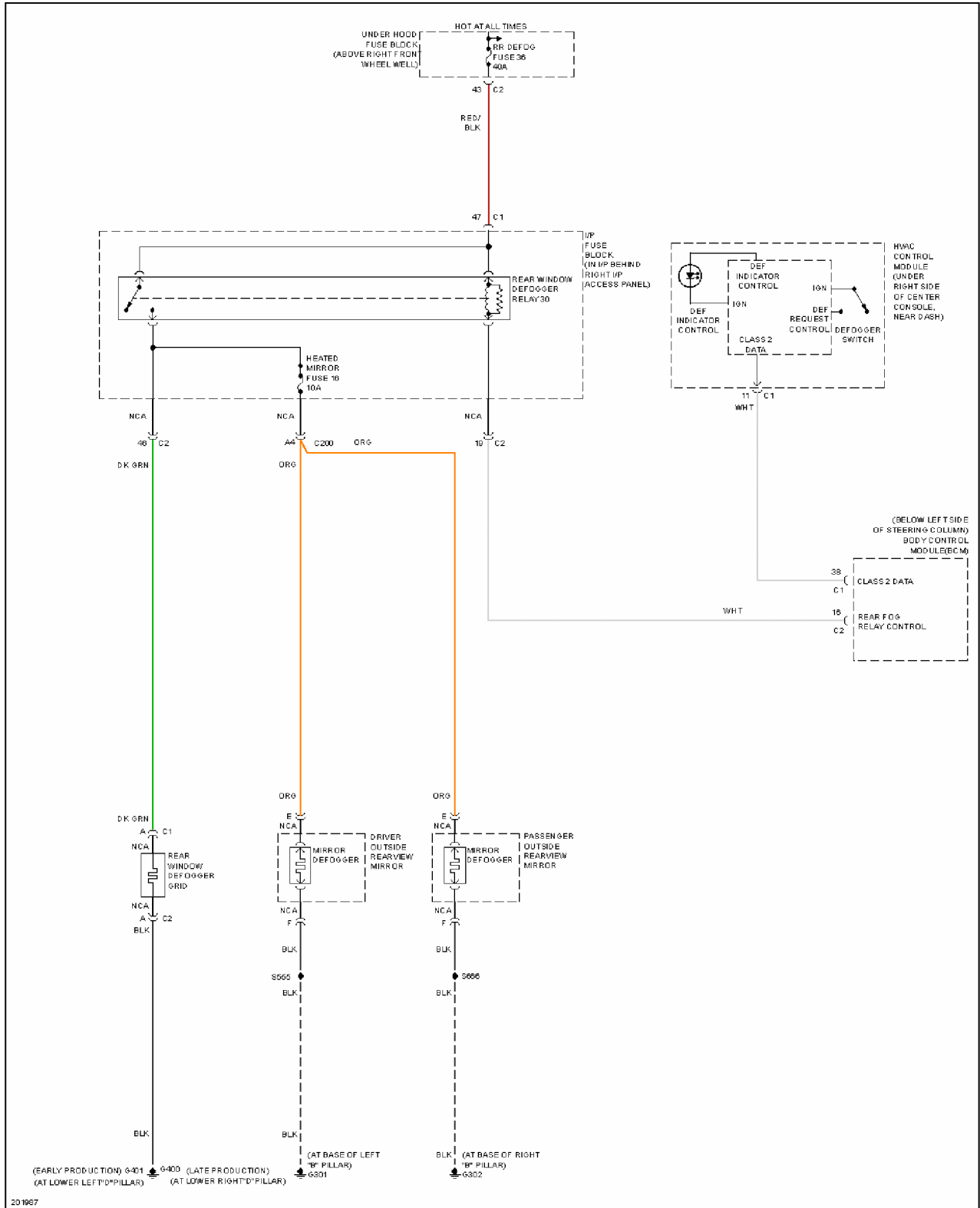

Fig. 13: Defoggers Circuit

ELECTRONIC SUSPENSION

2005 Chevrolet Uplander

2005 SYSTEM WIRING DIAGRAMS Chevrolet - Uplander

3.5L VIN 8

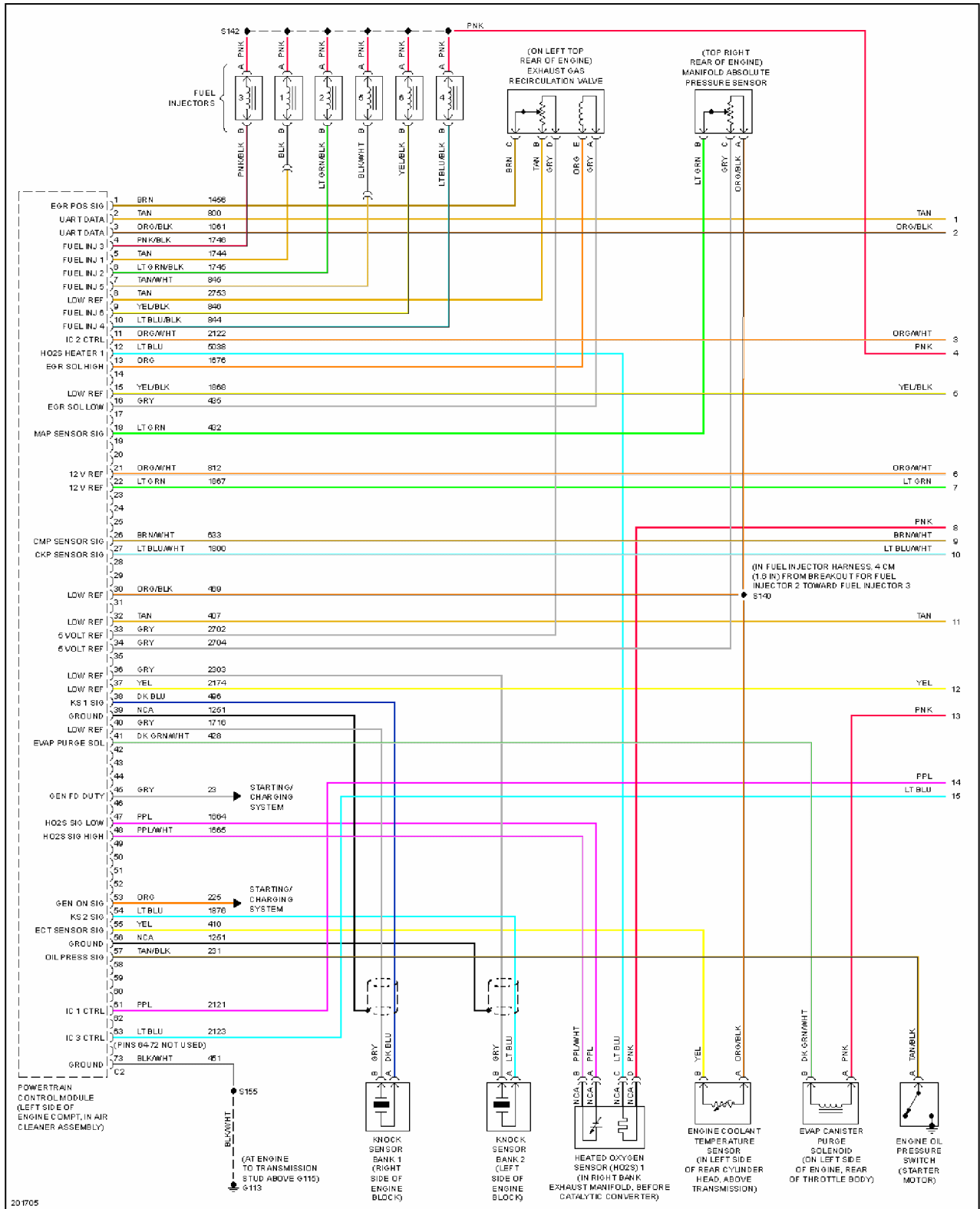

Fig. 15: 3.5L VIN 8, Engine Performance Circuit (1 of 4)

2005 Chevrolet Uplander

2005 SYSTEM WIRING DIAGRAMS Chevrolet - Uplander

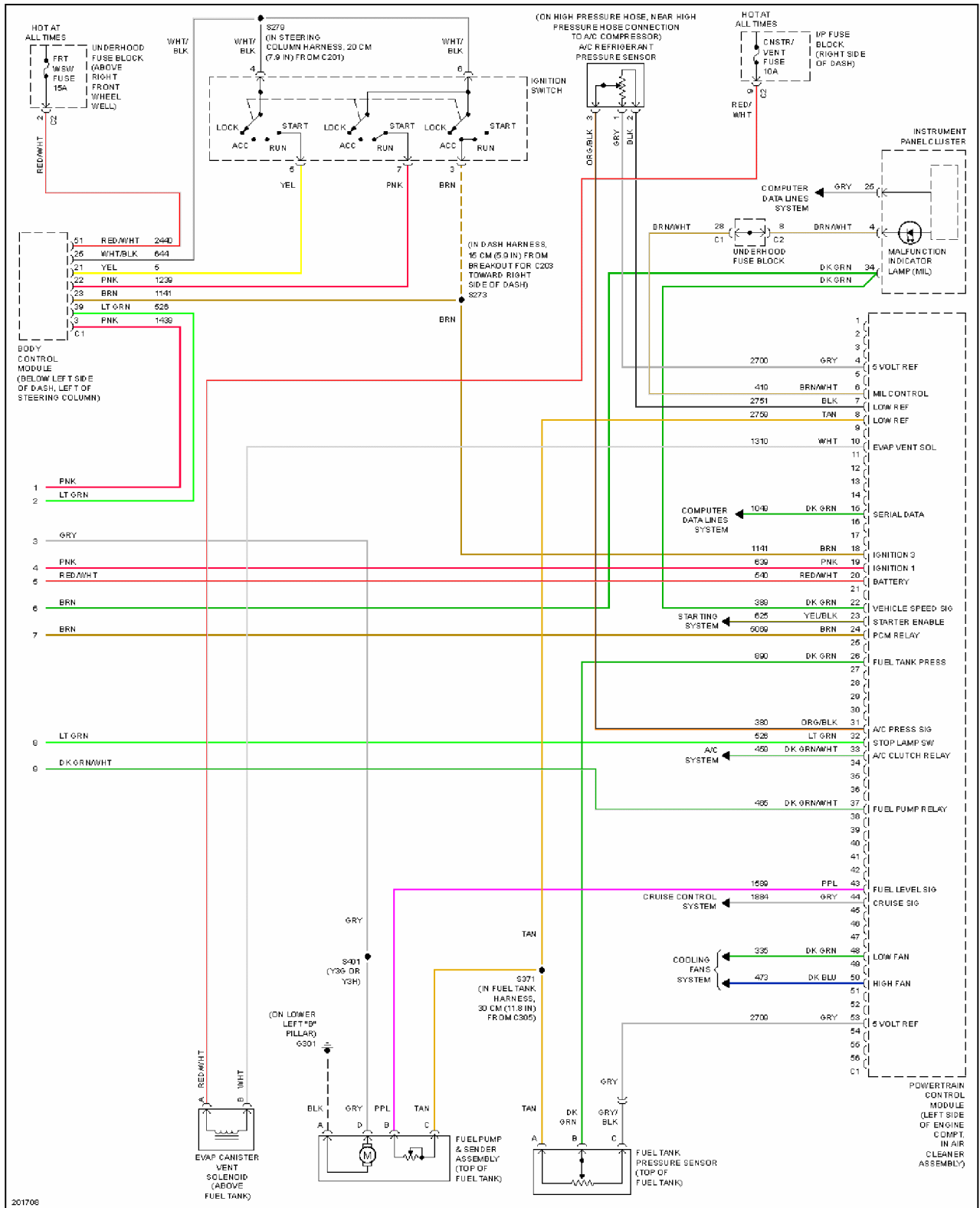

Fig. 18: 3.5L VIN 8, Engine Performance Circuit (4 of 4)

EXTERIOR LIGHTS

2005 Chevrolet Uplander

2005 SYSTEM WIRING DIAGRAMS Chevrolet - Uplander

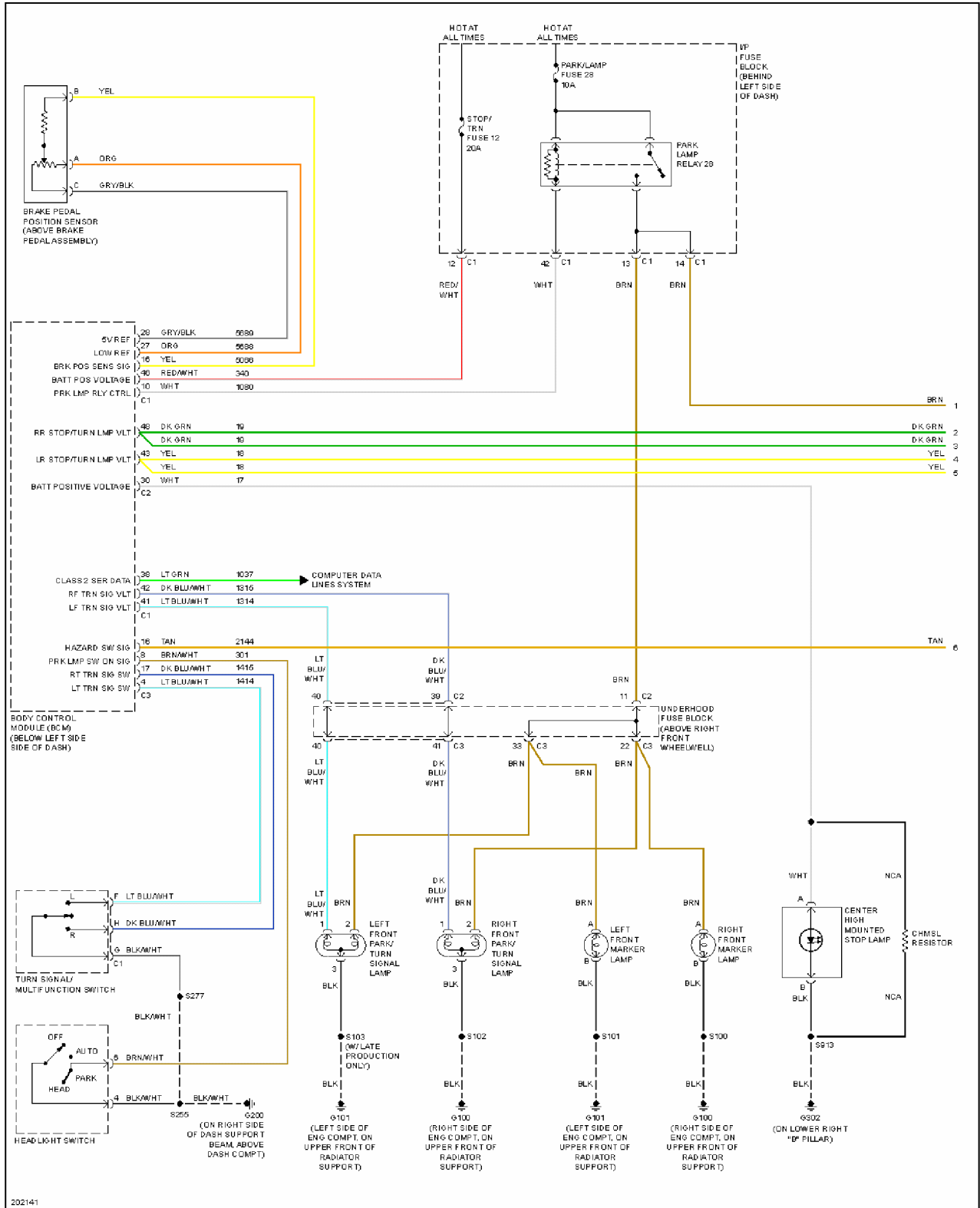

Fig. 20: Exterior Lamps Circuit (1 of 2)

2005 Chevrolet Uplander

2005 SYSTEM WIRING DIAGRAMS Chevrolet - Uplander

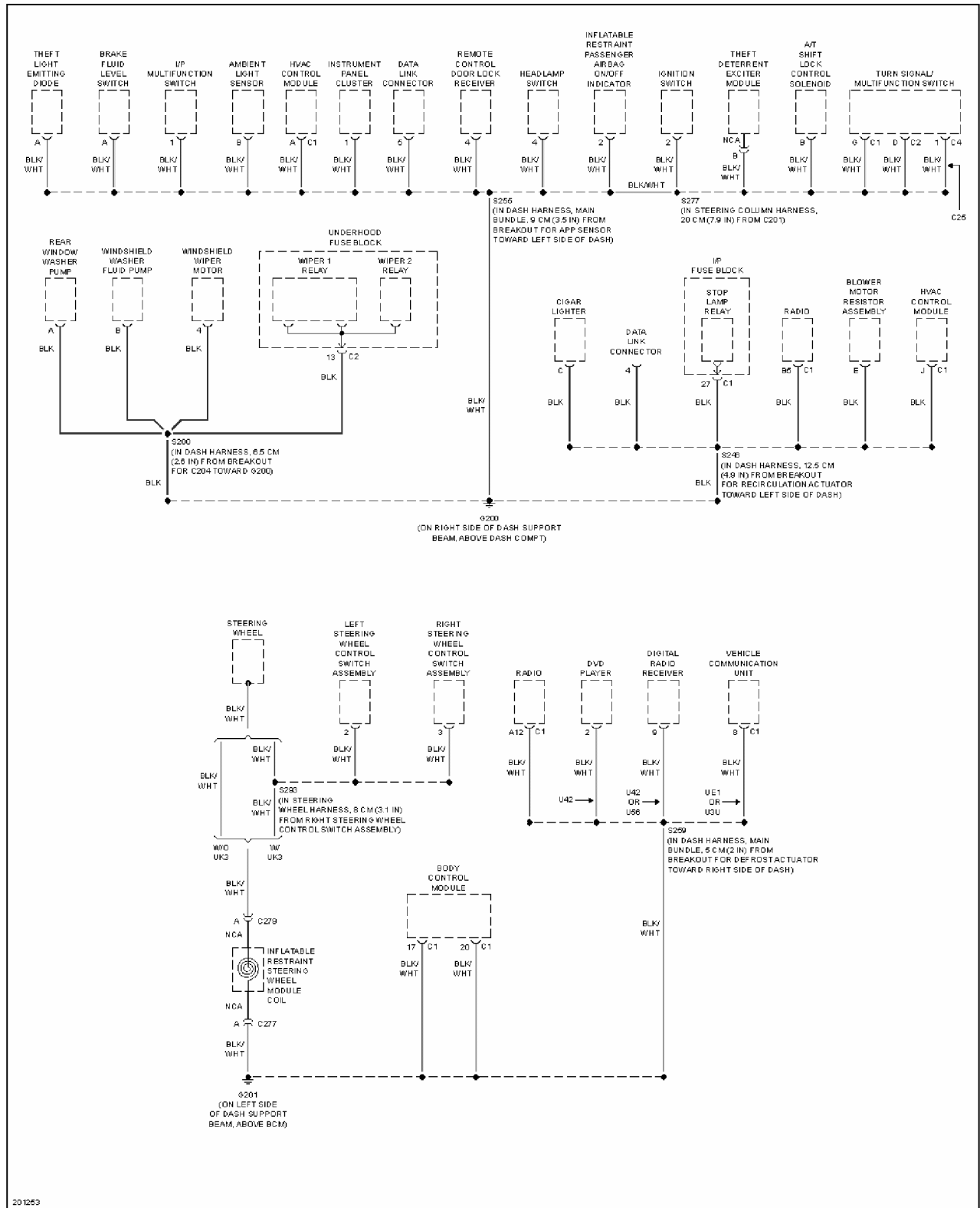

Fig. 23: Ground Distribution Circuit (2 of 5)

2005 Chevrolet Uplander

2005 SYSTEM WIRING DIAGRAMS Chevrolet - Uplander

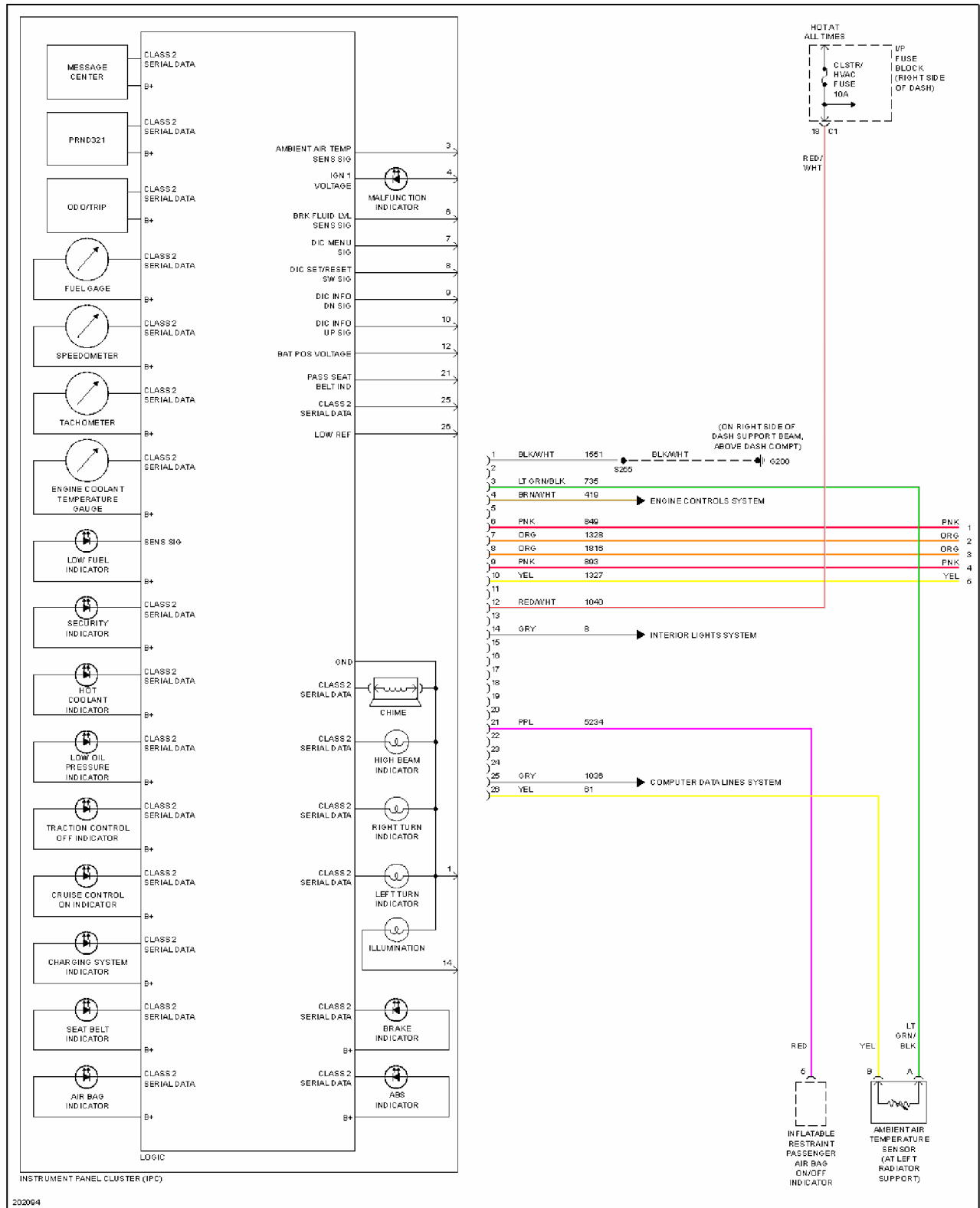

Fig. 29: Instrument Cluster Circuit (1 of 2)

2005 Chevrolet Uplander

2005 SYSTEM WIRING DIAGRAMS Chevrolet - Uplander

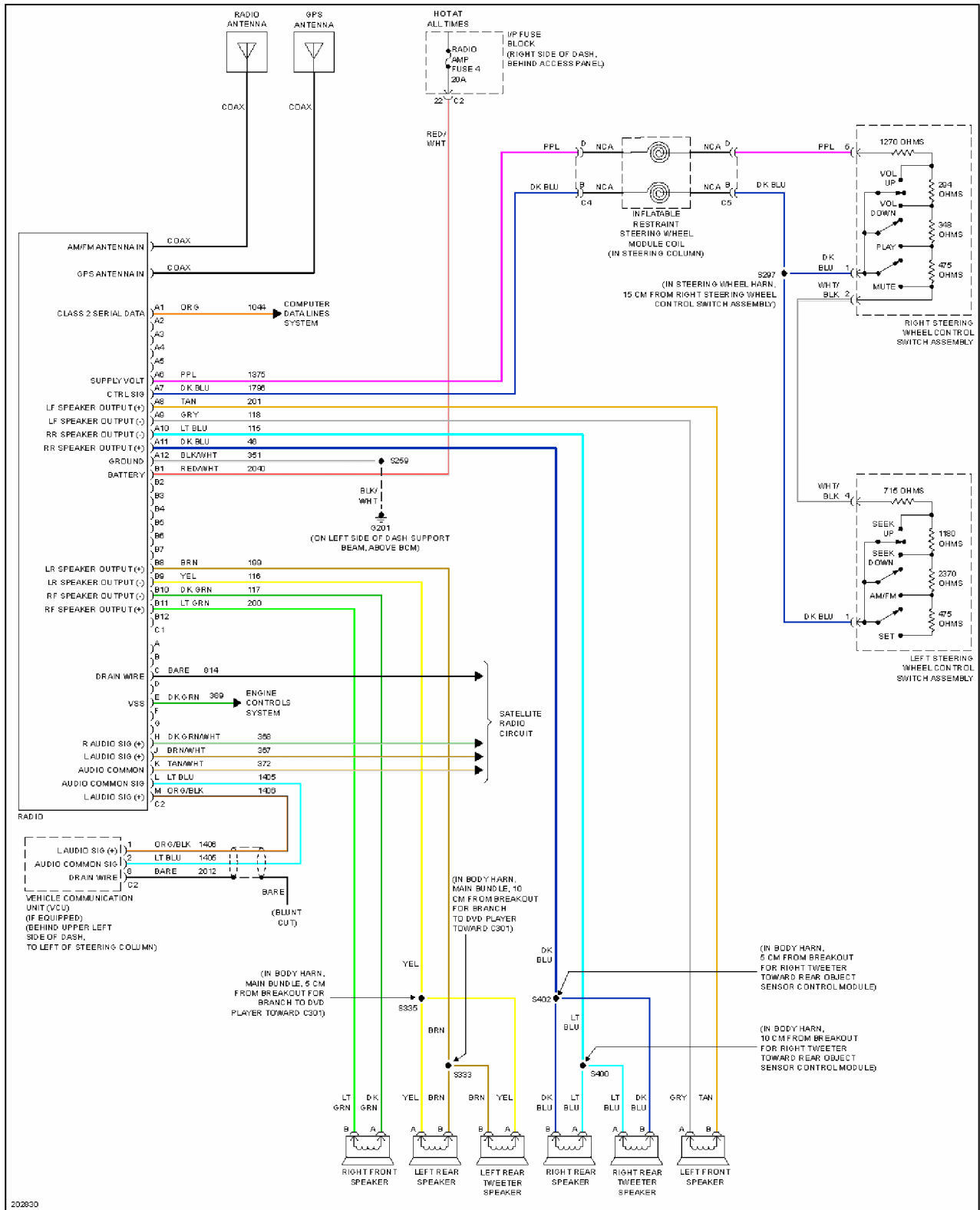

Fig. 49: Radio Circuit, W/O Rear Entertainment