

FOREWORD

This manual introduces 650NK (CF650 model) maintenance information, disassembly procedure, check & adjustment methods, troubleshooting and technical specifications. There are illustrations, drawings to guide your operation.

CFMOTO has final explanations to this manual information. Without our prior written approval, the manual cannot be duplicated and disclosed to third party.

CFMOTO reserves rights to make improvements and modifications to the products without prior notice. Overhaul and maintenance should be done according to actual condition of vehicle.

This manual is compiled according to standard GB9969.1-1998 and GB/T19678-2005.

INDEX

General Information	1
Periodic Maintenance	2
Fuel System (EFI)	3
Cooling System	4
Engine Top End	5
Clutch	6
Engine Lubrication System	7
Engine Removal/Installation	8
Crankshaft/Transmission	9
Wheels/Tires	10
Final Drive	11
Brakes	12
Suspension	13
Steering	14
Frame	15
Electrical System	16

Click on index line to go.

1-6 GENERAL INFORMATION

Tightening Sequence

Generally, when installing a part with several bolts, nuts or screws, start them all in their holes and tighten them in snug fit. Then tighten them according to specified sequence to prevent case warpage or deformation which can lead to malfunction. Conversely when loosening the bolts, nuts or screws, first loosen all of them by a quarter turn and then remove them. If the specified sequences is not indicated, tighten the fasteners alternating diagonally.

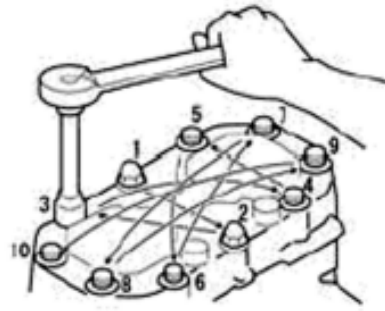

Tightening Torque

Incorrect torque applied to a bolt, nut or screw may lead to serious damage. Tighten fasteners to the specified torque by using a good quality torque wrench. Often, the tightening sequence is followed twice initial tightening and final tightening torque.

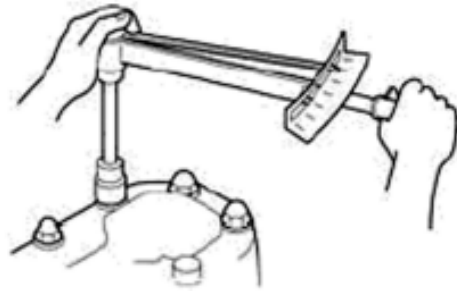

Proper Force

Use common sense during disassembly and assembly. Excessive force can cause expensive or hard to repair damage. When necessary, remove screws that have non-permanent locking agent applied using an impact driver. Use a plastic-faced mallet whenever tapping is necessary.

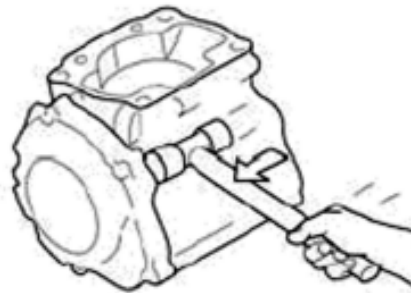

Gasket and O-ring

Hardening, shrinkage, or damage of both gaskets and O-ring after disassembly can reduce sealing performance.



Liquid Gasket, Non-permanent Locking Agent

For applications that require Liquid Gasket or a non-permanent locking agent, clean the surfaces so that no oil residue remains before applying liquid gasket or non-permanent locking agent. Do not apply them excessively, excessive application can clog oil passages and causes serious damage.



Periodic Maintenance Chart

The scheduled maintenance must be done in accordance with this chart to keep the motorcycle in good running condition. The initial maintenance is vitally important and must not be neglected.

■: This service must be performed by an authorized CFMOTO dealer.

*: For higher odometer readings, repeat at the frequency interval established here.

#: Service more frequently when operating in severe conditions; dusty, wet, muddy, high speed, or frequent starting/stopping.

1. Periodic Inspection

INSPECTION	FREQUENCY	*ODOMETER READINGS → km×1000						See Page	
		Whichever Comes First ↓ Every	1	6	12	18	24		30
■ Air filter element - clean				●		●		●	2-14
■ Valve clearance - inspect	42000km								2-19
Throttle control system (play, smooth return, no drag) - inspect	year	●		●		●		●	2-15
Idle speed - inspect		●		●		●		●	2-16
■ Fuel leak (fuel hose and pipe) - inspect	year	●		●		●		●	2-17
■ Fuel hose and pipe damage - inspect	year	●		●		●		●	2-17
■ Fuel hose and pipe installation condition - inspect	year	●		●		●		●	2-17
■ Throttle body—clean			●	●	●	●	●	●	—
Coolant level - inspect		●		●		●		●	2-18
Coolant leak (radiator hose and pipe) - inspect	year	●		●		●		●	2-18
Radiator hose damage - inspect	year	●		●		●		●	2-18
Radiator hose installation condition - inspect	year	●		●		●		●	2-18
■ Air intake system damage - inspect				●		●		●	
Clutch and Drive Train									
Clutch operation (play, disengagement, engagement) - inspect		●		●		●		●	2-25
Drive chain lubrication condition - inspect #	600km								2-27
Drive chain slack - inspect #	1000km								2-28
Drive chain wear - inspect #				●		●		●	2-30
■ Drive chain guide wear - inspect				●		●		●	2-30

Engine Top End

Valve Clearance Inspection

NOTE

- Valve clearance must be checked and adjusted when the engine is cold (room temperature).
- Remove the cylinder head cover (see Cylinder Head Cover Removal in the EngineTop End chapter)
- Unscrew the upper [A] and lower [B] caps on the clutch cover.
- Check the valve clearance when the pistons are at TDC.
- The pistons are numbered beginning with the engine left side.
- Using a wrench [A] on the crankshaft rotation bolt, turn the crankshaft clockwise until the “1/T” mark on the timing rotor is aligned with the notch [B] in the edge of the upper hole in the clutch cover for #1 piston and “2/T” mark for #2 piston.

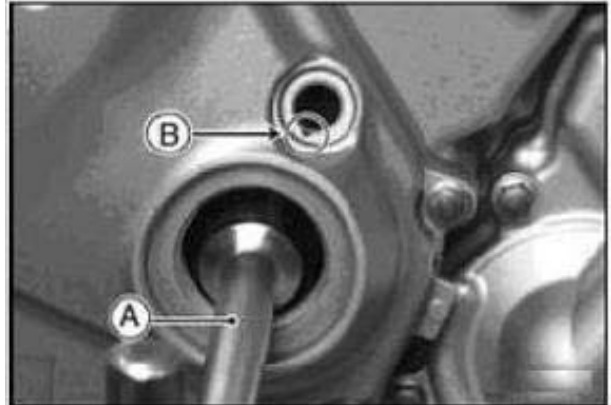
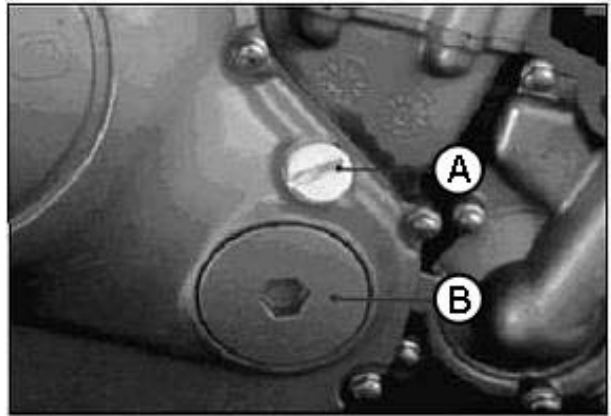

- 1/T Mark [A]
- 2/T Mark [B]
- Hole [C] of Upper Cap
- Notch [D] in Edge of Upper Hole

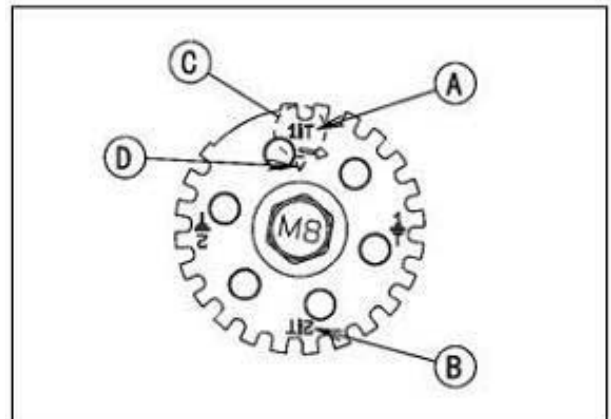

- Using the feeler gauge [A], measure the valve clearance between cam and valve lifter.

Valve Clearance

Standard:

Exhaust: 0.22~0.31 mm (0.0087~0.0122 in.)

Intake: 0.15~0.21 mm (0.0059~0.0083 in.)

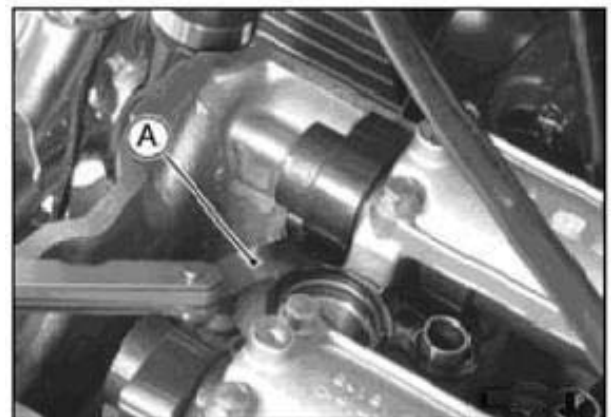

2-38 PERIODIC MAINTENANCE

Second Step

- Turn the ignition switch to P (Park) position.
- The city light, taillight and license plate light should go on.
- ★ If the light does not go on, inspect or replace the following item.
Ignition Switch (see Switch Inspection in the Electrical System chapter)

Third Step

- Turn on the turn signal switch [A] (left or right position).
- The left or right turn signal lights [B] (front and rear) according to the switch position should flash.
- The turn signal indicator light (LED) [C] in the meter unit should flash.
- ★ If the each light does not flash, inspect or replace the following item.

Turn Signal Light Bulb (see Turn Signal Light Bulb Replacement in the Electrical System chapter)

Meter Unit for Turn Signal Light Indicator Light (LED) (see Electronic Combination Meter Unit Inspection in the Electrical System chapter)

Turn Signal Relay Fuse 10 A (see Fuse Inspection in the Electrical System chapter)

Turn Signal Switch (see Switch Inspection in the Electrical System chapter)

Turn Signal Relay (see Turn Signal Relay Inspection in the Electrical System chapter)

Harness (see Wiring Inspection in the Electrical System chapter)

- Push the turn signal switch.
- The turn signal lights and indicator light (LED) should go off.
- ★ If the light does not go off, inspect or replace the following item.
Turn Signal Switch (see Switch Inspection in the Electrical System chapter)
- Turn Signal Relay (see Turn Signal Relay Inspection in the Electrical System chapter)

Fourth Step

- Set the dimmer switch [A] to low beam position.
- Start the engine.
- The low beam headlight should go on.
- ★ If the low beam headlight does not go on, inspect or replace the following item.

Headlight Low Beam Bulb (see Headlight Bulb Replacement in the Electrical System chapter)

Headlight Fuse 10 A (see Fuse Inspection in the Electrical System chapter)

Dimmer Switch (see Switch Inspection in the Electrical System chapter)

Headlight Relay in Relay Box (see Relay Circuit Inspection in the Electrical System chapter)

Harness (see Wiring Inspection in the Electrical System chapter)

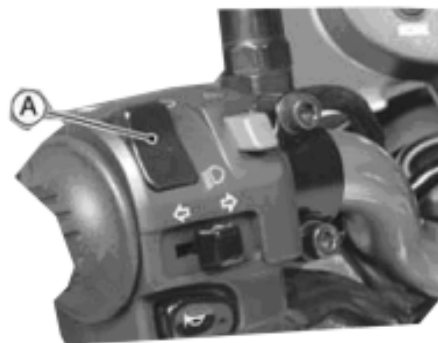
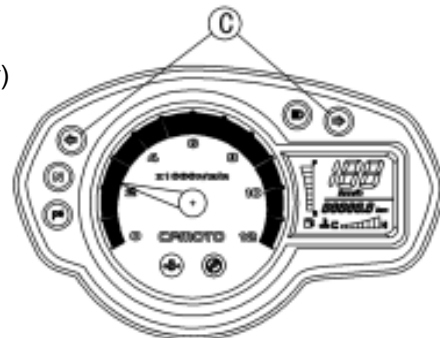
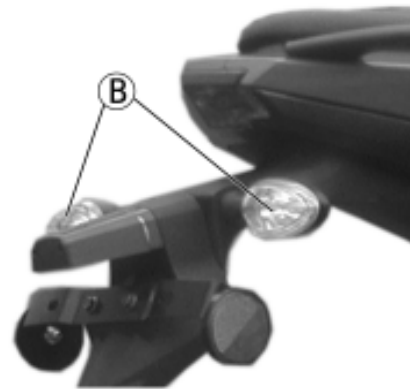
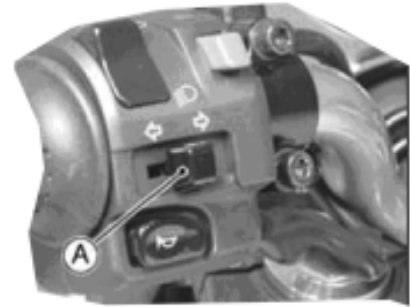

Special Tools

Oil Pressure Gauge

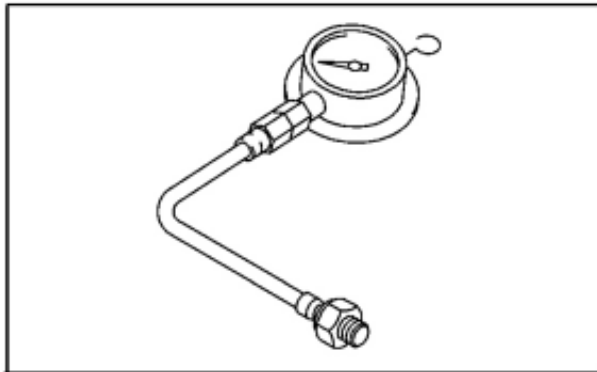

Needle Adaptor Set

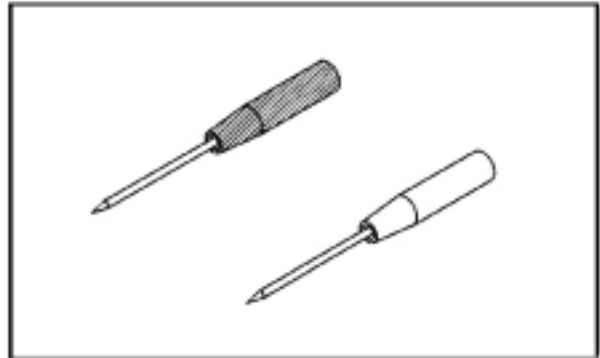

Throttle Sensor Setting Harness

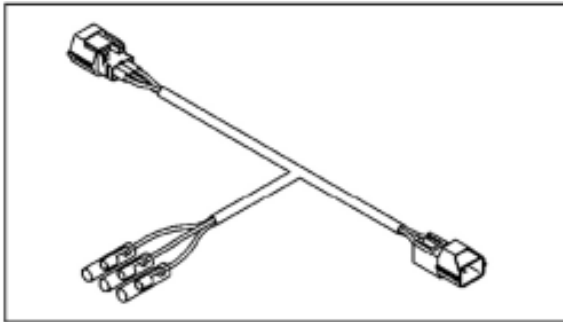

Hand Tester

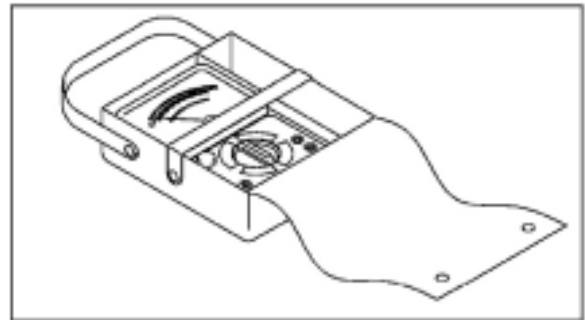

Fuel Pressure Gauge Adaptor

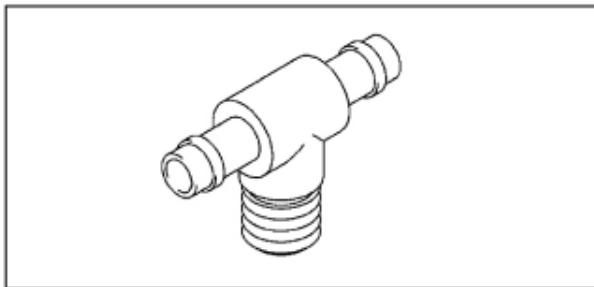

Fuel Hose

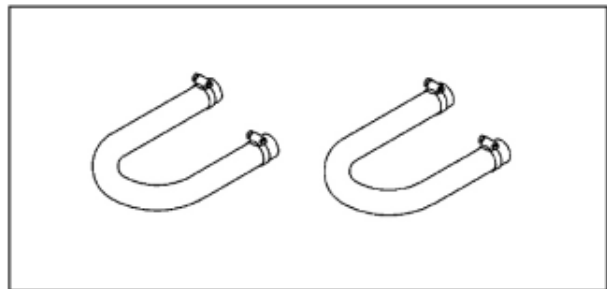

Peak Voltage Adapter

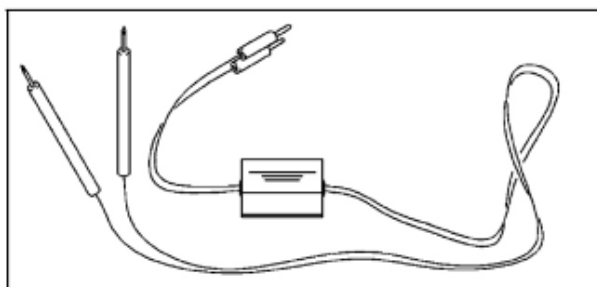

Roll-over Sensor

Roll-over Sensor Resistance Inspection (when not tilted)

- Remove roll-over sensor [C] (see Roll-over Sensor Removal/Installation).
- Disconnect roll-over sensor connector [B].
- Connect hand tester [A] to connector [B] and measure the resistance.

Roll-over Sensor Output Resistance:

Standard: $R \leq 0.5 \Omega$

Roll-over sensor is placed as shown in the right figure.

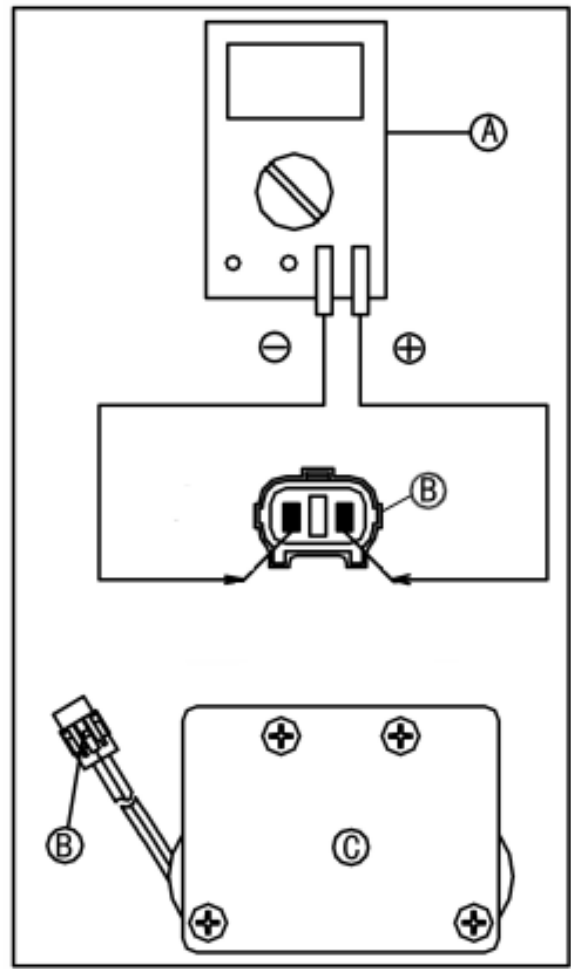

Roll-over Resistance Inspection (when not tilted)

- Remove roll-over sensor [C] (see Roll-over Sensor Removal/Installation).
- Disconnect roll-over sensor connector [B].
- Connect hand tester [A] to connector [B] and measure the resistance.
- Tilt the sensor 40~50° or more [C] right or left, then and measure the output resistance.

Roll-over Sensor Output Resistance

Standard: $R = 62 \pm 5k \Omega (20^\circ C)$

Sensor tilted 40~50° or more [C] right or left

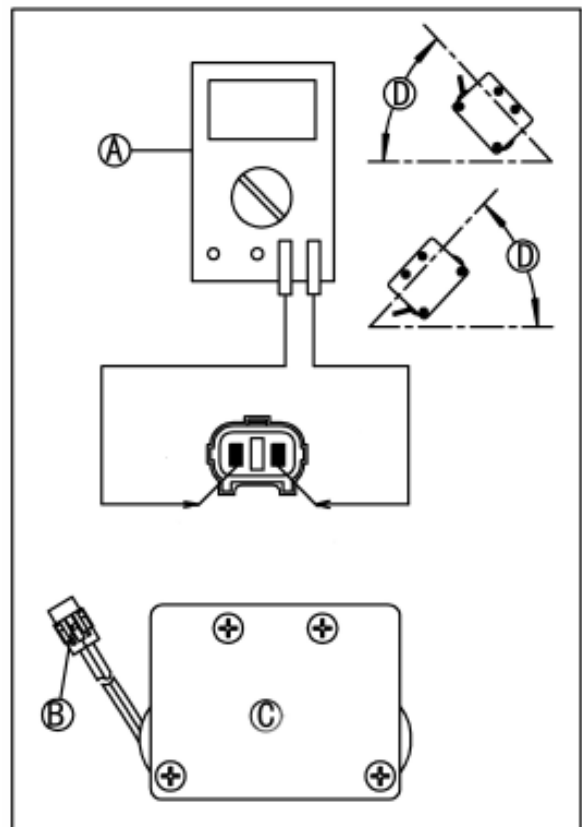

3-70 FUEL SYSTEM (EFI)

Fuel Injectors

Injector Signal Test

- Prepare two test light sets with male terminals as shown.

Rating of Bulb [A]: 12 V x3 ~ 3.4 W

Terminal Width [B]: 1.8 mm (0.071 in.)

Terminal Thickness [C]: 0.8 mm (0.031 in.)

CAUTION
<p>Do not use larger terminals than specified above. A larger terminal could damage the injector main harness connector (female), leading to harness repair or replacement.</p> <p>Be sure to connect bulbs in series. The bulb works as a current limiter to protect the solenoid in the injector from excessive current.</p>

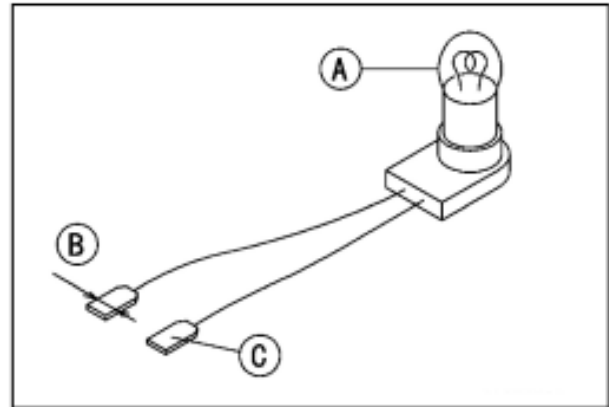

Test Lights Wiring

- Remove the fuel tank(see FuelTank removal).
 - Remove the air filter housing (seeAir Filter Housing removal).
 - Disconnect the connector of fuel injector [A].
 - Connect each test light set [B] to the injector sub harness connector [C].
 - Turn the ignition switch ON.
 - While cranking the engine with the starter motor, watch the test lights.
- ★ If the test lights flicker at regular intervals, the injector circuit in the ECU, and the wiring are good. Perform the "Injector Resistance Inspection".
- Injector signals can be also confirmed by connecting the hand tester (x10 V AC) instead of the test light set to the injector main harness (female) connector. Crank the engine with the starter motor, and check to see if the hand oscillates at regular intervals.
- ★ If the test light doesn't flicker (or the tester needle doesn't oscillates), check the wiring and connectors again. If the wiring is good, check the injector voltage. If the wiring is good, inspect the ECU for its ground and power supply (see ECU Power Supply Inspection).

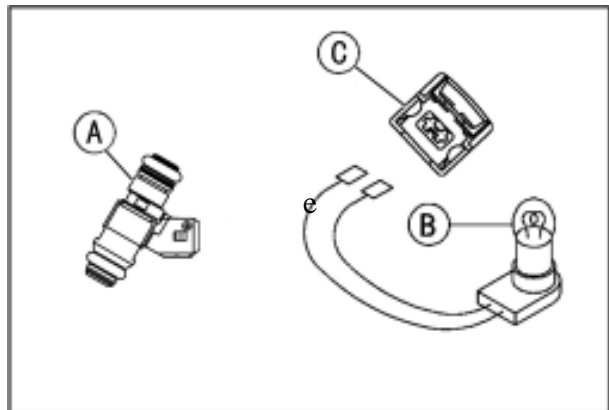

Valves

Valve Seat Inspection

- Remove the valve (see Valve Removal).
- Check the valve seating surface [A] between the valve [B] and valve seat [C]
- Measure the outside diameter [D] of the seating pattern on the valve seat.
- ★If the outside diameter is too large or too small, repair the seat (see Valve Seat Repair).

Valve Seating Surface Outside Diameter

EX: 27.6 ~ 27.7mm

IN: 32.6 ~32.7mm

- Measure the seat width [E] of the portion where there is no build-up carbon (white portion) of the valve seat with a vernier caliper.
- ★If the width is too wide [G], too narrow [H] or uneven [J], repair the seat (see Valve Seat Repair).

Valve Seating Surface Width

EX: 0.5 ~1.0mm

IN: 0.5 ~1.0 mm

Valve Seat Repair

- Repair the valve seat with the valve seat cutters [A].

Special Tools -

Valve Seat Cutter Holder Bar [C]:

Valve Seat Cutter Holder Φ 4.5 [B]:

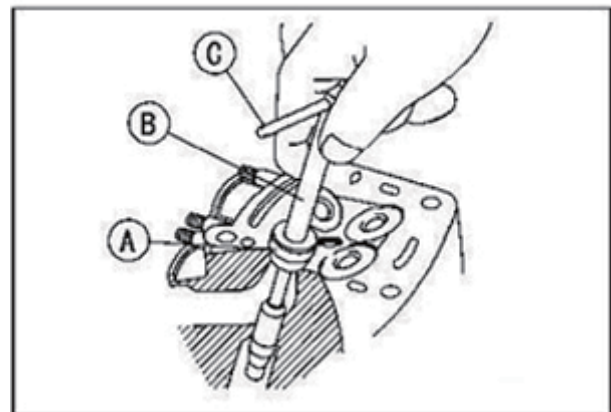
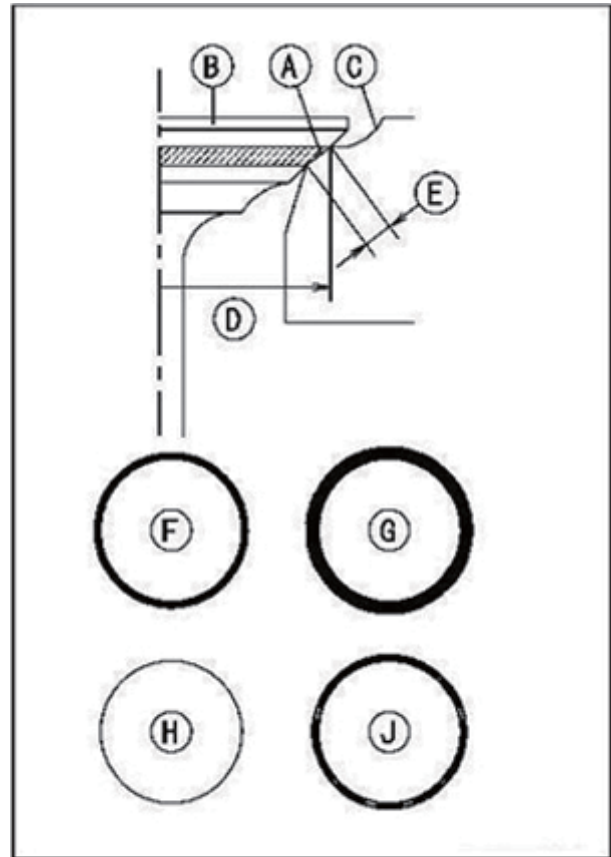

6-8 CLUTCH

Clutch Cover

Release Shaft Removal

- Remove the clutch cover (see Clutch Cover Removal).
- Pull the lever and shaft assembly straight out of the clutch cover

Release Shaft Installation

- Apply high-temperature grease to the oil seal lips on the upper ridge of the clutch cover.
- Apply engine oil to the needle bearings in the hole of the clutch cover.
- Apply molybdenum disulfide grease to the pusher-holding portion [A] on the release shaft.
- Install the washer [B] and spring [C].
- Insert the release shaft straight into the upper hole of the clutch cover.

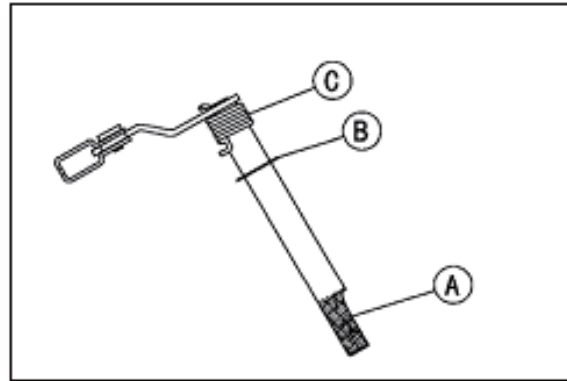

CAUTION
When inserting the release shaft, be careful not to remove the spring of the oil seal.

- Fit the spring [A] as shown.
Release Shaft [B]
Clutch Cover [C]

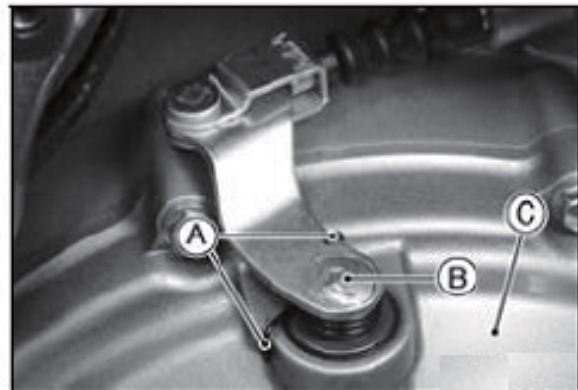

7-10 ENGINE LUBRICATION SYSTEM

Oil Pan

Oil Pan Removal

- Remove:
 - Engine oil (Drain, see Engine Oil Change in the Periodic Maintenance chapter)
 - Exhaust Pipe (see Exhaust Pipe Removal in the Engine Top End chapter)
 - Muffler body (see Muffler Body Removal in the Engine Top End chapter)
 - Oil Pan Bolts [A]
 - Oil Pan [B]
 - Gasket [C]
 - Damper [D]

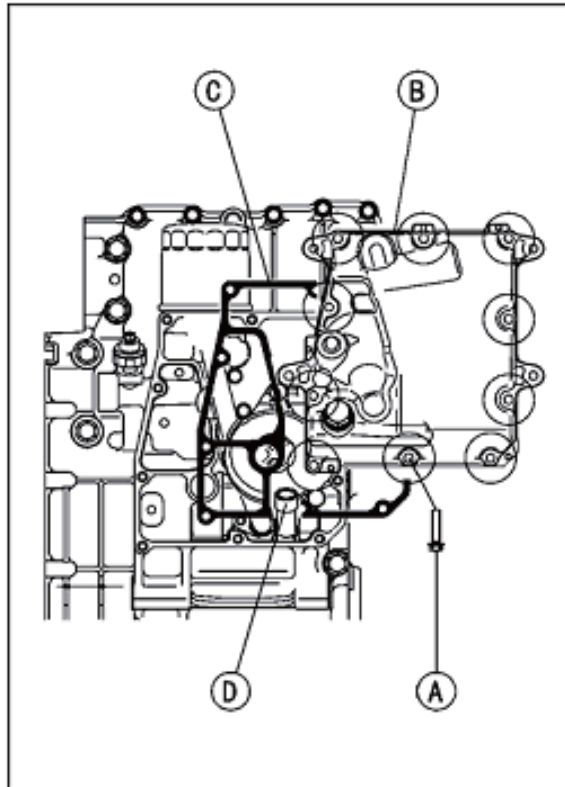

- Remove the following from the oil pan as necessary:
 - Filter Plate Bolts [A]
 - Filter Plate [B]
 - Filter [C]

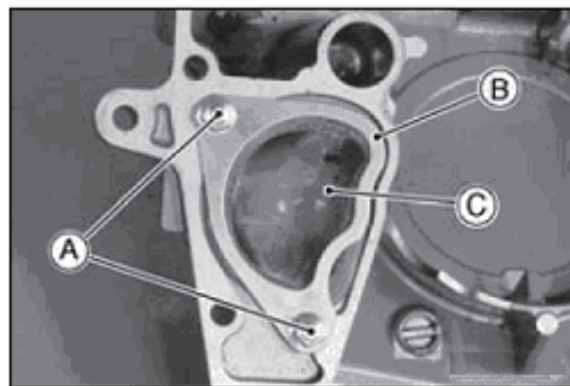

- Remove the following from the lower crankcase half as necessary:
 - Oil Screen [A]
 - Oil Pipe Plate Bolt [B]
 - Oil Pipe Plate [C]
 - Oil Pipes [D]
 - Oil Pressure Relief Valve [E]

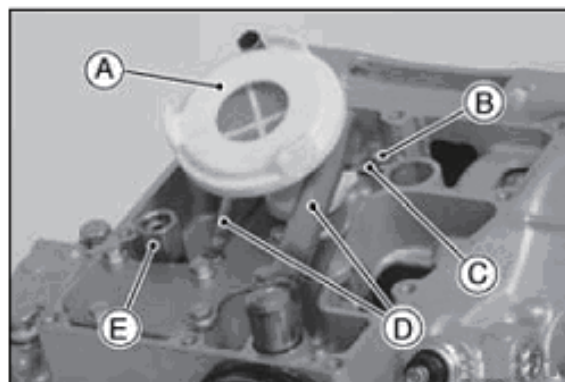

9-10 CRANKSHAFT/TRANSMISSION

Crankcase Splitting

Crankcase Splitting

- Remove:
 - Engine (see Engine Removal in the Engine Removal/Installation chapter)
 - Cylinder (see Cylinder Removal in the Engine Top End chapter)
 - Pistons (see Piston Removal in the Engine Top End chapter)
 - Stator Motor (see Starter Motor Removal in the Electrical System chapter)
 - Clutch (see Clutch Removal in the Clutch chapter)
 - Transmission Assy (see Transmission Assy Removal)
 - Alternator Rotor (see Alternator Rotor Removal in the Electrical System chapter)

- Remove the upper crankcase bolts [A] and the washers.

- Remove the oil pan, relief valve, oil screen and oil pipes (see Oil Pan Removal in the Engine Lubrication System chapter).
- Remove the lower crankcase bolts.
 - Firstly loosen the M7 bolts, secondly the M8 bolts and lastly the M9 bolts.
 - M7 Bolts [A]
 - M8 Bolts [B]
 - M9 Bolts [C] and Washers

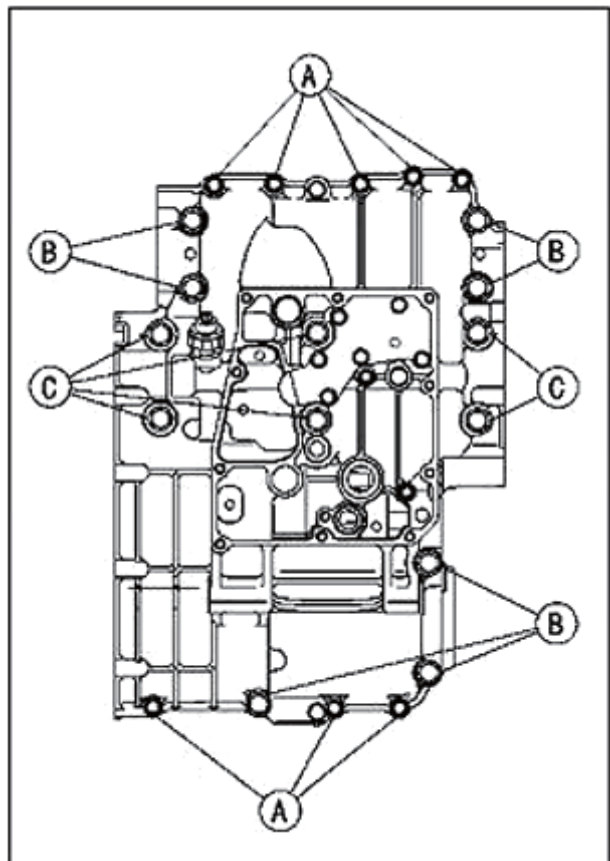
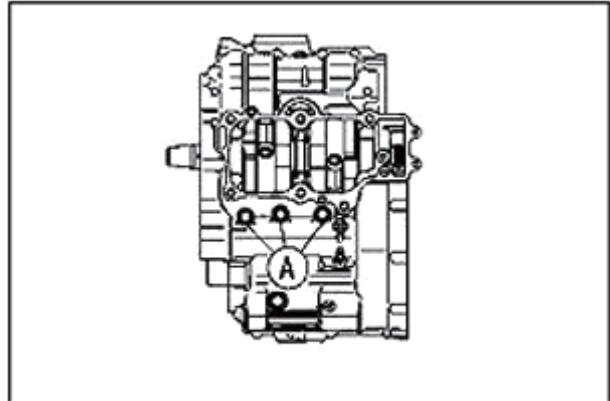

WHEELS/TIRES 10-4

Item	Standard	Service Limit	
Wheels (Rims)			
Rim Runout:			
Axial	TIR 0.5 mm (0.02 in.) or less	TIR 1.0 mm (0.04 in.)	
Radial	TIR 0.8 mm (0.03 in.) or less	TIR 1.0 mm (0.04 in.)	
Axle Runout/100 mm (3.94 in.)	TIR 0.03 mm (0.0012 in.) or less	TIR 0.2 mm (0.008 in.)	
Wheel Balance	10 g (0.35 oz.) or less	---	
Balance Weights	10 g (0.35 oz.), 20 g (0.71 oz.), 30 g (1.06 oz.)	---	
Rim Size:			
Front	17 × 3.50	---	
Rear	17 × 4.50	---	
Tires			
Air Pressure (when Cold):			
Front	Up to 236 kg (520.51 lb) load: 280 kPa (2.80 kgf/cm ² , 39.8 psi)	---	
Rear	Up to 325 kg (716.8 lb) load: 280 kPa (2.80 kgf/cm ² , 39.8 psi)	---	
Tread Depth:			
Front	4.5 mm (0.18 in.)	0.8~1mm	
Rear	5.5 mm (0.22 in.)	0.8~1mm	
Standard Tires:	Make, Type	Size	
	Front	CST TYRE	120/70R17M/C(58H)
	Rear	CST TYRE	160/60R17M/C(69H)

WARNING

Use the same manufacturer's tires on both front and rear wheels.

11-10 FINAL DRIVE

Engine Sprocket Removal

- Remove:
 - Engine Sprocket Cover Bolts [A]
 - Engine Sprocket Cover [B]

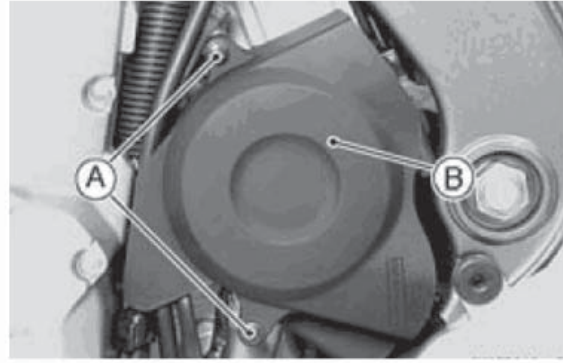

- Remove:
 - Speed Sensor Bracket Bolts [A]
 - Speed Sensor Bracket [B]

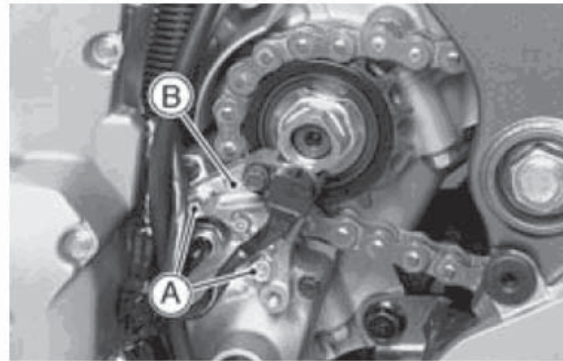

- Flatten out the bended washer [A].
- Remove the engine sprocket nut [B] and washer.

NOTE

- *When loosening the engine sprocket nut, hold the rearbrake on.*

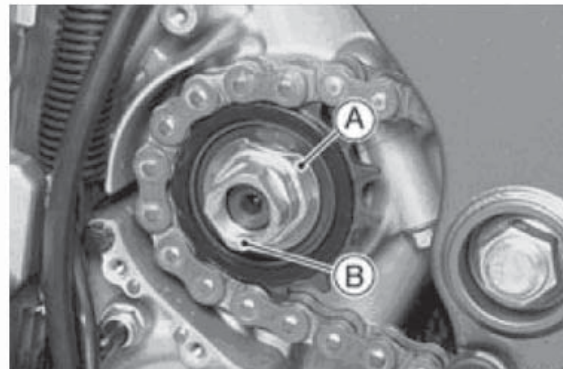

- Raise the rear wheel off the ground with stand.
- Remove the axle cotter pin, and loosen the rear axle nut.
- Loosen the drive chain (see Drive Chain Slack Adjustment in the Periodic Maintenance chapter).
- Remove the drive chain from the rear sprocket toward the right.
- Pull the engine sprocket [A] with drive chain [B] off the output shaft [C].
- Disengage the drive chain from the engine sprocket.

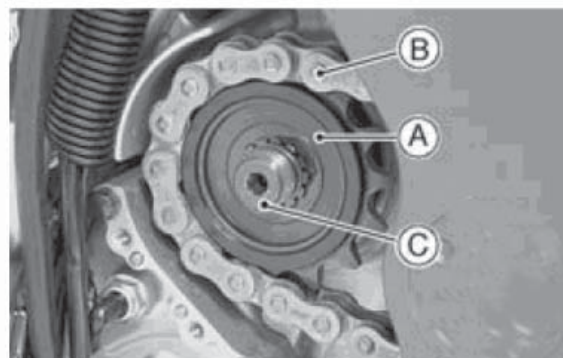

- Remove the lower bearing inner race [A] which is pressed onto the steering stem with a suitable commercially available chisel [B].

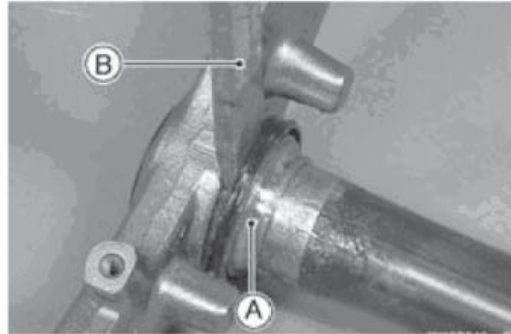

Stem, Stem Bearing Installation

- Replace the bearing outer races with new ones.
- Apply grease to the outer races, and drive them into the head pipe at the same time.

Special Tool - Bearing Driver Set [A]

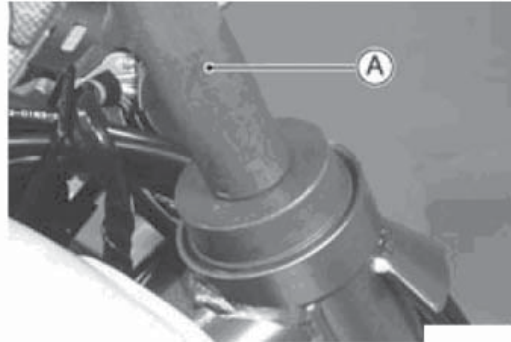

- Replace the bearing inner races and oil seal with new ones.
- Apply grease to the oil seal.
- Drive the lower ball bearing inner race applied the grease onto the stem.

Special Tools - Steering Stem Bearing Driver, 42.5 [A]

Steering Stem Bearing Driver Adapter, 41.5 [B]

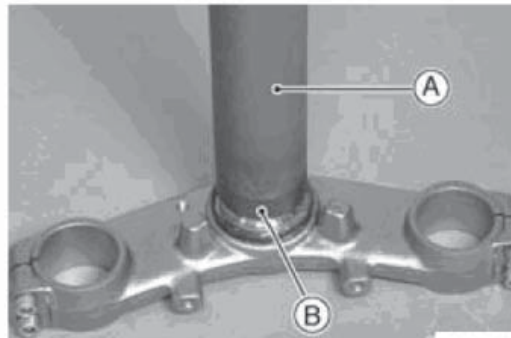

- Apply grease to the lower ball bearing [A], and install it onto the stem.
- Apply grease to the upper ball bearing [B] and inner race [C].

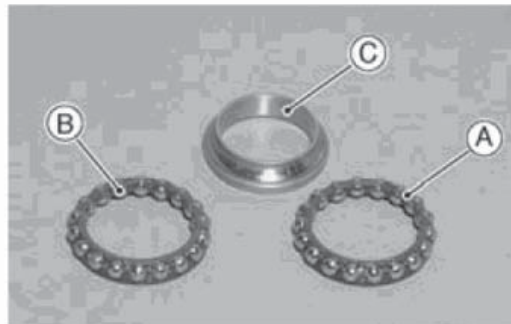

- Install the stem [A] through the head pipe and install the ball bearing [B] and inner race [C] on it.
- Install the stem cap [D] and steering stem nut [E].

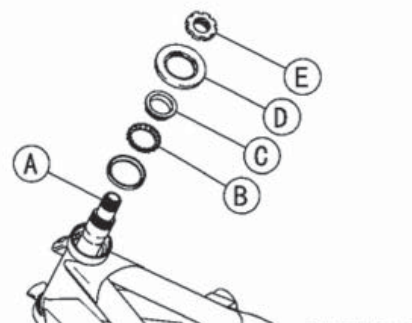

16-22 ELECTRICAL SYSTEM

Charging System

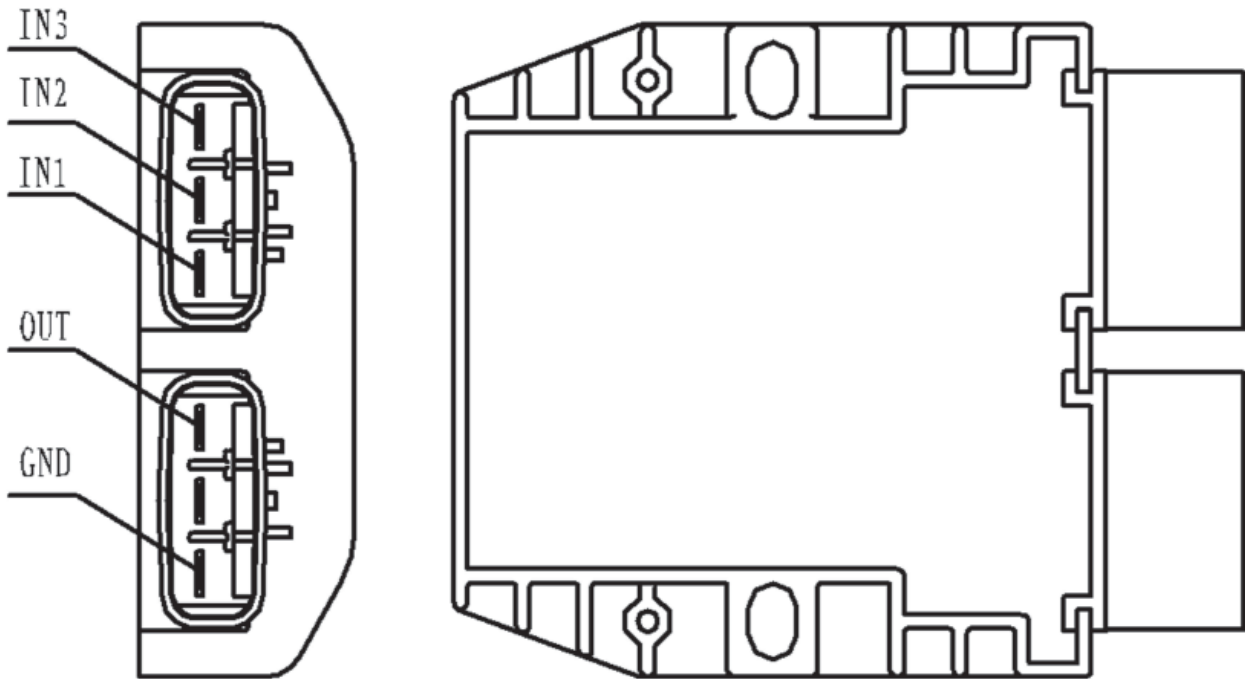

- Using a hand tester, measure the resistance between the following pair of terminals.
- ★ If any reading is out of the specification, replace the regulator/rectifier with a new one.
- Set the hand tester to Diode range (mv).

★After is the engine is running(at 5000 rpm), when the magneto is normal and the battery is fully charged, if the voltage between the red and green terminals is more than 15V or less than 13.5V, replace the regulator/rectifier with a new one.

NOTE

- If the hand tester displays less than 1.4 V when the probes are not connected, replace the batteries.

		Red Probe (+)				
		IN1	IN2	IN3	GND	OUT
Black Probe (-)	IN1		∞	∞	100 - 800	∞
	IN2	∞		∞	100 - 800	∞
	IN3	∞	∞		100 - 800	∞
	GND	∞	∞	∞		∞
	OUT	100 - 800	100 - 800	100 - 800	100 - 800	