

MODELS

00100030155

Model Code		Engine model	Transmission model	Fuel supply system
K62T	JERDEL6	4G63-SOHC (1,997 ml)	R4AW2 (2WD-4A/T)	MPI
	ENDEL6		R5M21 (2WD-5M/T)	
K64T	YNDL6	4D56 (2,477 ml)	R5M21 (2WD-5M/T)	Diesel fuel injection
	ZNDL6			
	ENDL6			
	ENDR6			
	CENDL6			
	JENDL6			
K75T	CENDEL6	4G64-SOHC (2,351 ml)	V5M21 (4WD-5M/T)	MPI
K74T	YNDFL6	4D56 Turbocharger with Intercooler (2,477 ml)	V5MT1 (4WD-5M/T)	Diesel fuel injection
	ZNDFL6			
	ENDFR6			
	JERDFL6		V4AW2 (4WD-4A/T)	
	GJENXFL6		V5MT1 (4WD-5M/T)	
	CENDFL6			
	JENDFL6			
	JENHFL6			

ENGINE COMPARTMENT

80100030614

4D56 <L.H. drive vehicles>

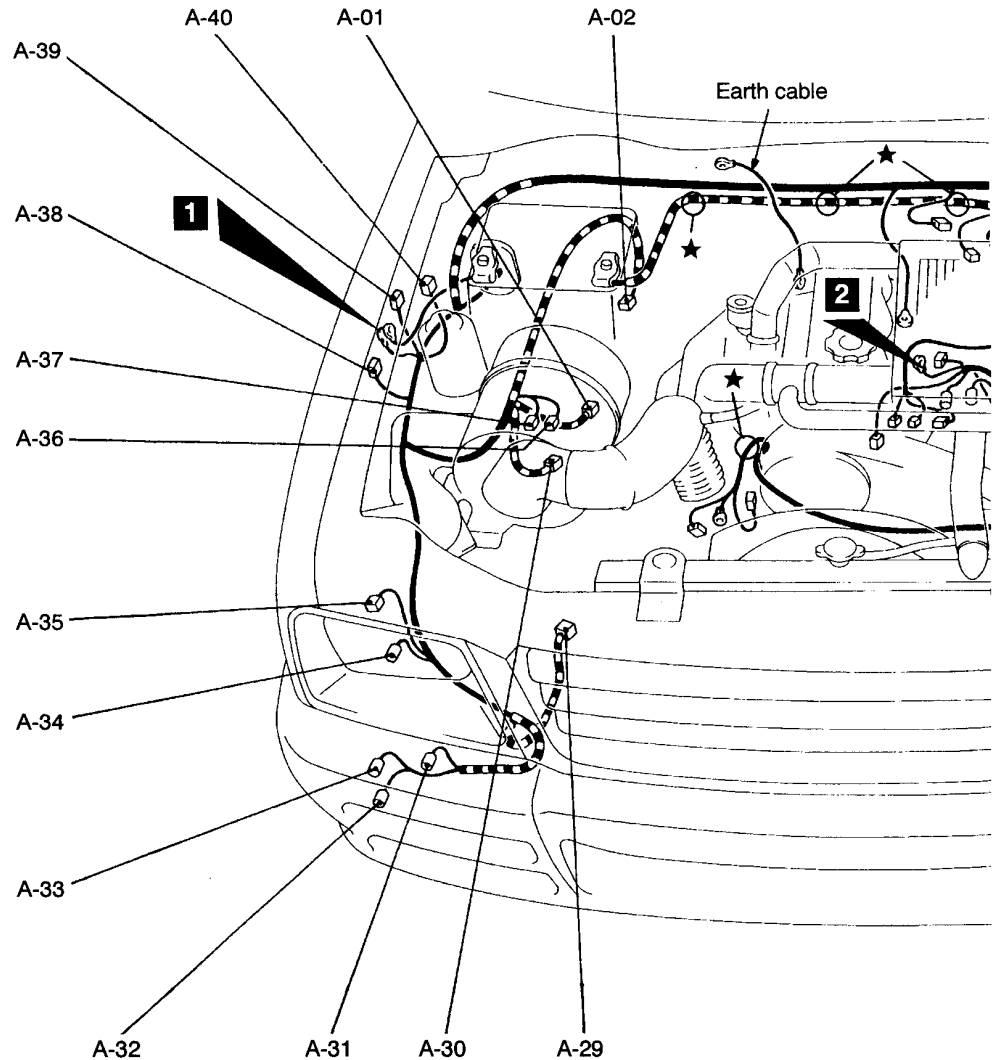
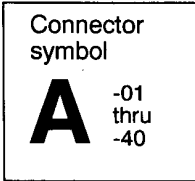

- | | | | |
|-------------|---|-------------|---|
| A-01 (2-B) | Wheel speed sensor (front: RH)
<2WD-ABS> | A-13 (4-B) | Rear fog lamp relay |
| A-02 (2-GR) | Free-wheeling hub engage switch
<4WD> | A-14 (6-L) | A/C wiring harness and front wiring harness combination <A/C> |
| A-03 (1) | Starter | A-15 (6-B) | Headlamp washer relay |
| A-04 (1-B) | Starter | A-16 (10-B) | DRL wiring harness or front wiring harness and front wiring harness combination |
| A-05 (4-B) | Windshield wiper motor | A-17 (4-B) | Battery cable wiring harness and front wiring harness combination |
| A-06 (2-B) | Brake fluid level sensor | A-18 (3) | Headlamp leveling unit (LH) |
| A-07 (2-B) | Wheel speed sensor (front: LH)
<2WD-ABS> | A-19 (10-B) | DRL wiring harness or front wiring harness and front wiring harness combination |
| A-08 (2-B) | ABS hydraulic unit | A-20 (3-B) | Headlamp (LH) |
| A-09 (10-B) | ABS hydraulic unit | | |
| A-10 (12-B) | DRL-ECU | | |
| A-11 (4-B) | DRL relay 2 | | |
| A-12 (4-B) | DRL relay 1 | | |

L.H. drive vehicles

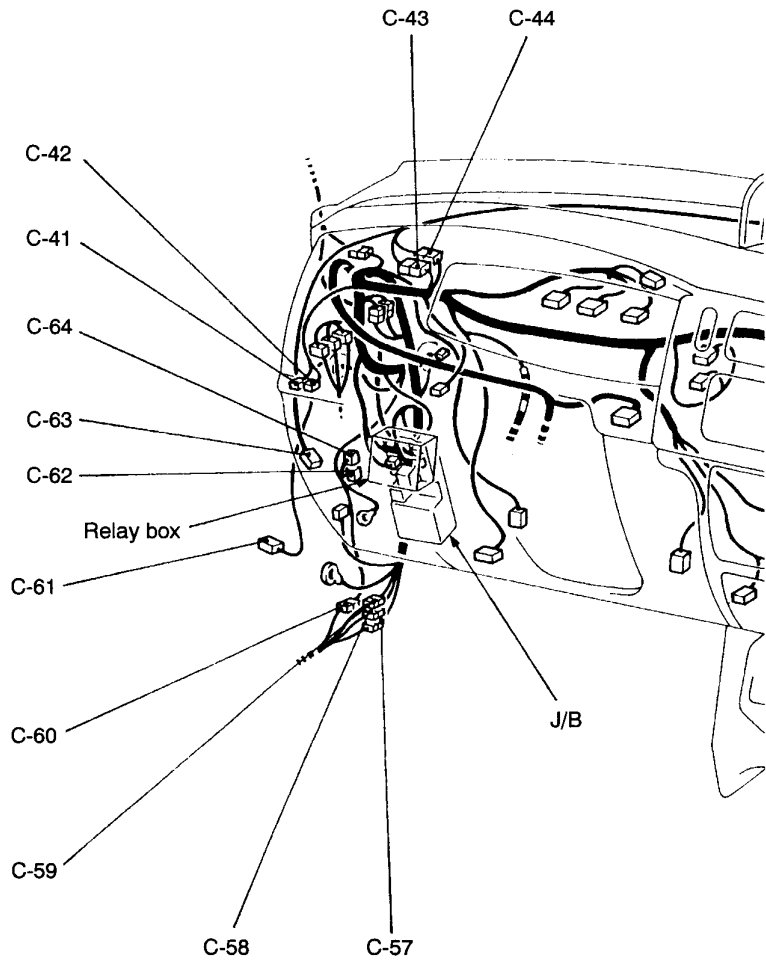
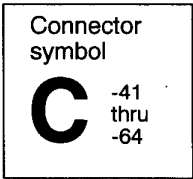

- | | | | |
|------------|---|-------------|-------------------------------|
| C-41 (6-B) | Rear fog lamp switch | C-48 (2-B) | Diode (for ABS circuit) |
| C-42 (4) | Rheostat or joint connector | C-49 (26-Y) | Engine-ECU <Petrol> |
| C-43 (5) | Body wiring harness and instrument panel wiring harness combination | C-49 (13) | Grow-ECU <Diesel> |
| C-44 (11) | Body wiring harness and instrument panel wiring harness combination | C-50 (16-Y) | Engine-ECU <Petrol> |
| C-45 (14) | Multi-meter | C-51 (22-Y) | Engine-ECU <Petrol> |
| C-46 (3) | Thermostat | C-52 (2-BR) | Side turn signal lamp (RH) |
| C-47 (8) | Compressor-ECU | C-53 (4) | Engine control relay <Petrol> |
| | | C-53 (4-BR) | Intercooler fan-ECU <Diesel> |
| | | C-54 (4) | Fuel pump relay <Petrol> |

DASH PANEL

R.H. drive vehicles

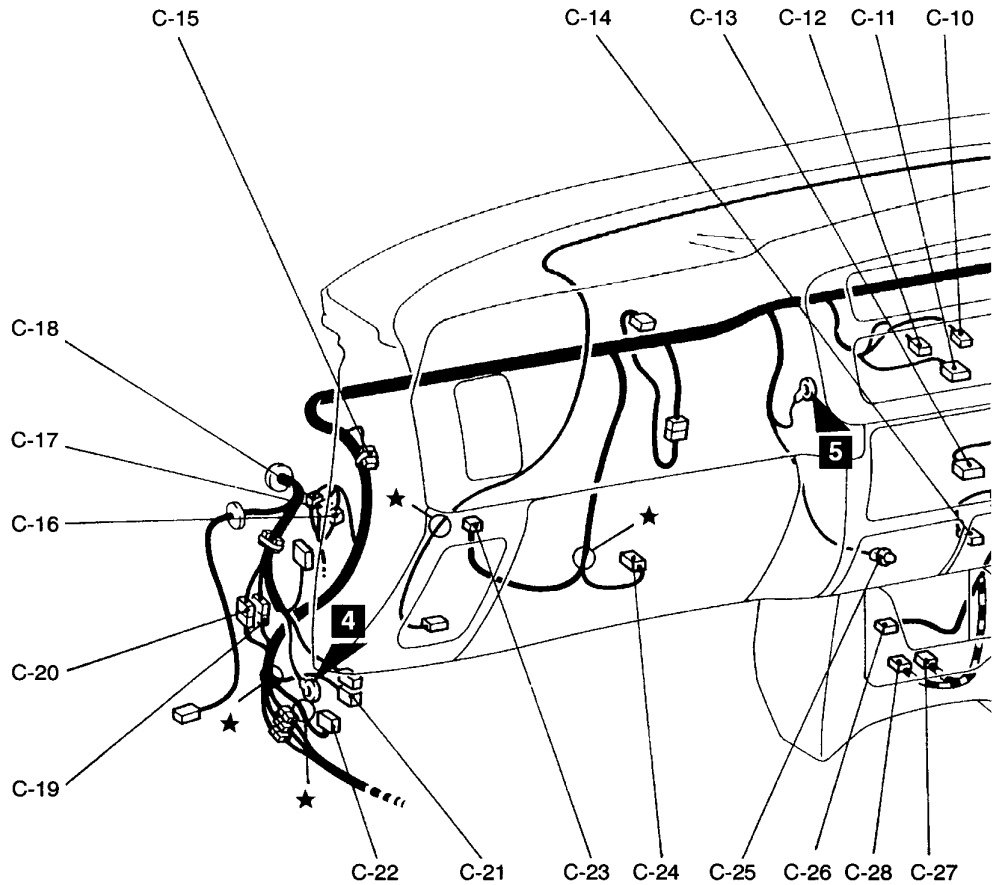
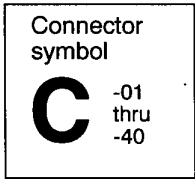

- | | | | |
|-------------|--|-----------|--|
| C-01 (22) | Body wiring harness and front wiring harness combination | C-13 (14) | Radio and tape player |
| C-02 (17) | Body wiring harness and front wiring harness combination | C-14 (2) | Cigarette lighter |
| C-04 (14) | Combination meter | C-15 (1) | No connection (reed switch) |
| C-05 (10) | Combination meter | C-16 (5) | Body wiring harness and front door wiring harness (passenger's side) combination |
| C-06 (14-B) | Combination meter | C-17 (6) | Body wiring harness and front door wiring harness (passenger's side) combination |
| C-07 (1-B) | Combination meter | C-18 (7) | Body wiring harness and front door wiring harness (passenger's side) combination |
| C-09 (10) | Hazard switch | C-19 (14) | Body wiring harness and front wiring harness combination |
| C-10 (6) | A/C switch | | |
| C-11 (4) | Clock | | |
| C-12 (10) | Blower switch | | |

POWER DISTRIBUTION SYSTEM

90100040210

L.H. drive vehicles

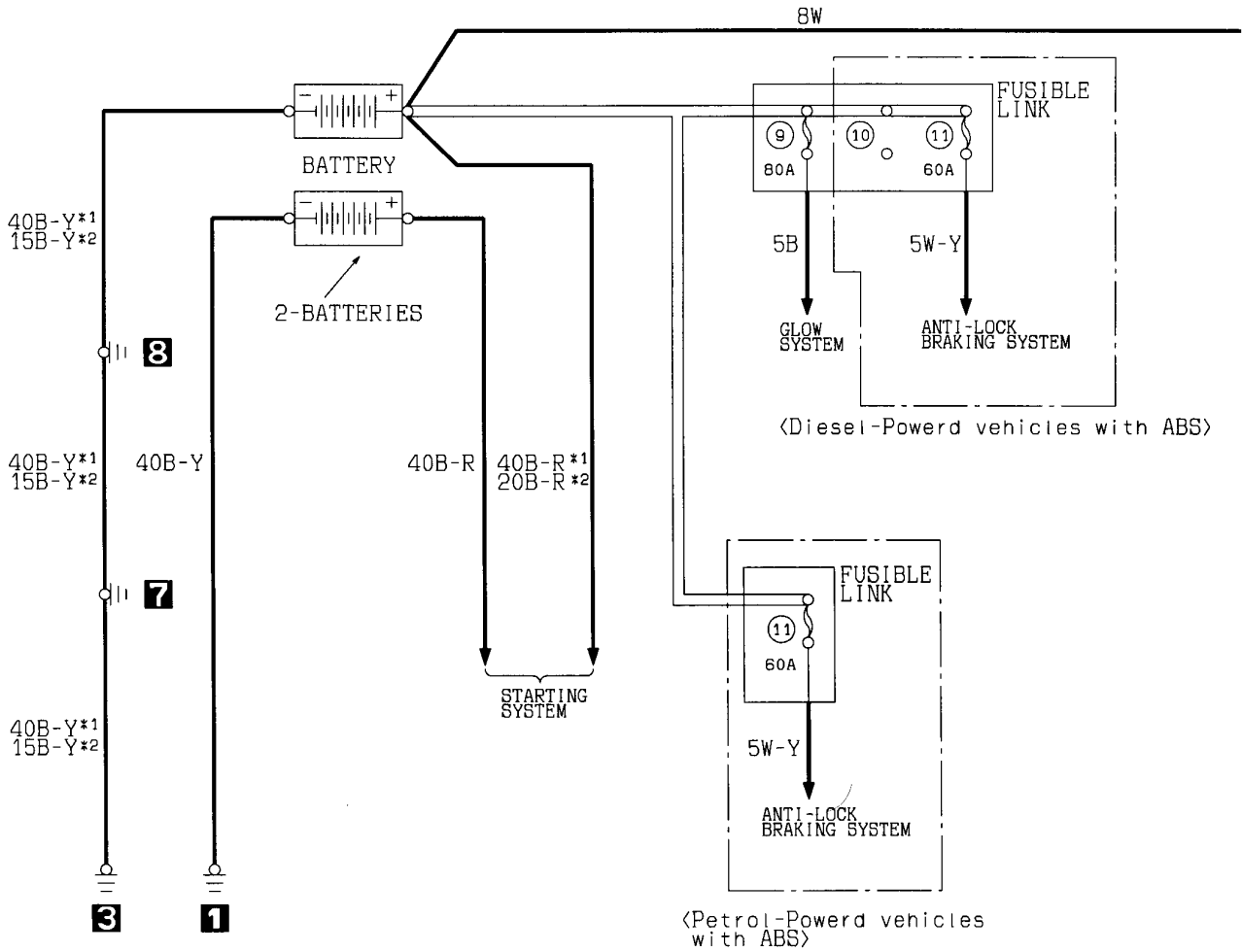

Remarks
 *1: Diesel
 *2: Petrol

(A-56X)



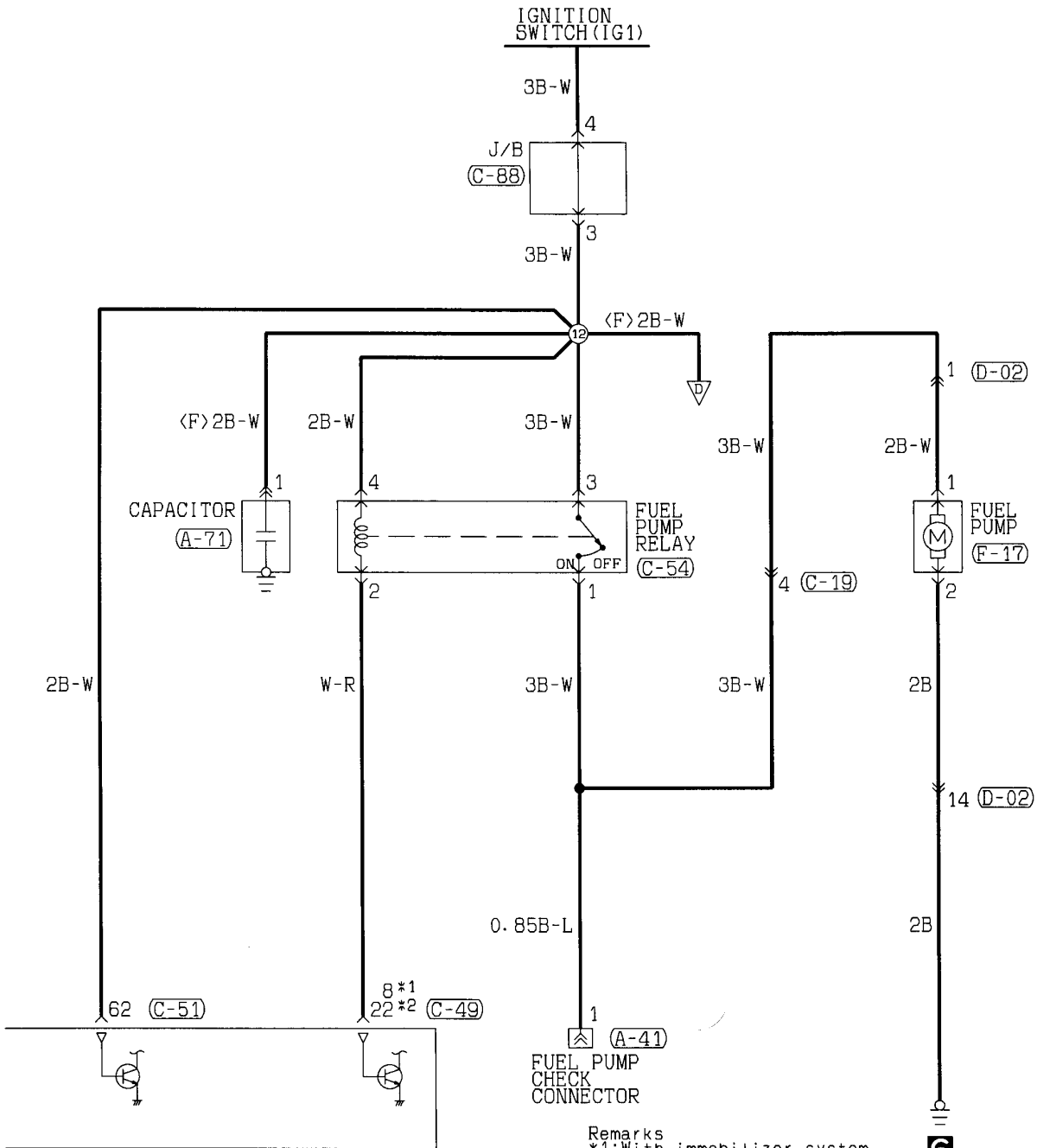

(C-49)

1	2	3	4	5	6	7	8	9	10	11	12	13
14	15	16	17	18	19	20	21	22	23	24	25	26

(C-50)

31	32	33	34	35	36	37	38
39	40	41	42	43	44	45	46

(C-51)

51	52	53	54	55	56	57	58	59	60	61
62	63	64	65	66	67	68	69	70	71	72

(C-53)

1	2
3	4

(C-54)

1	2
3	4

(C-79)

1	2	3	4	5	6	7		
8	9	10	11	12	13	14	15	16

(C-81)

1	2	3	4	5		
6	7	8	9	10	11	12

REAR FOG LAMP

90101200112

L.H. drive vehicles

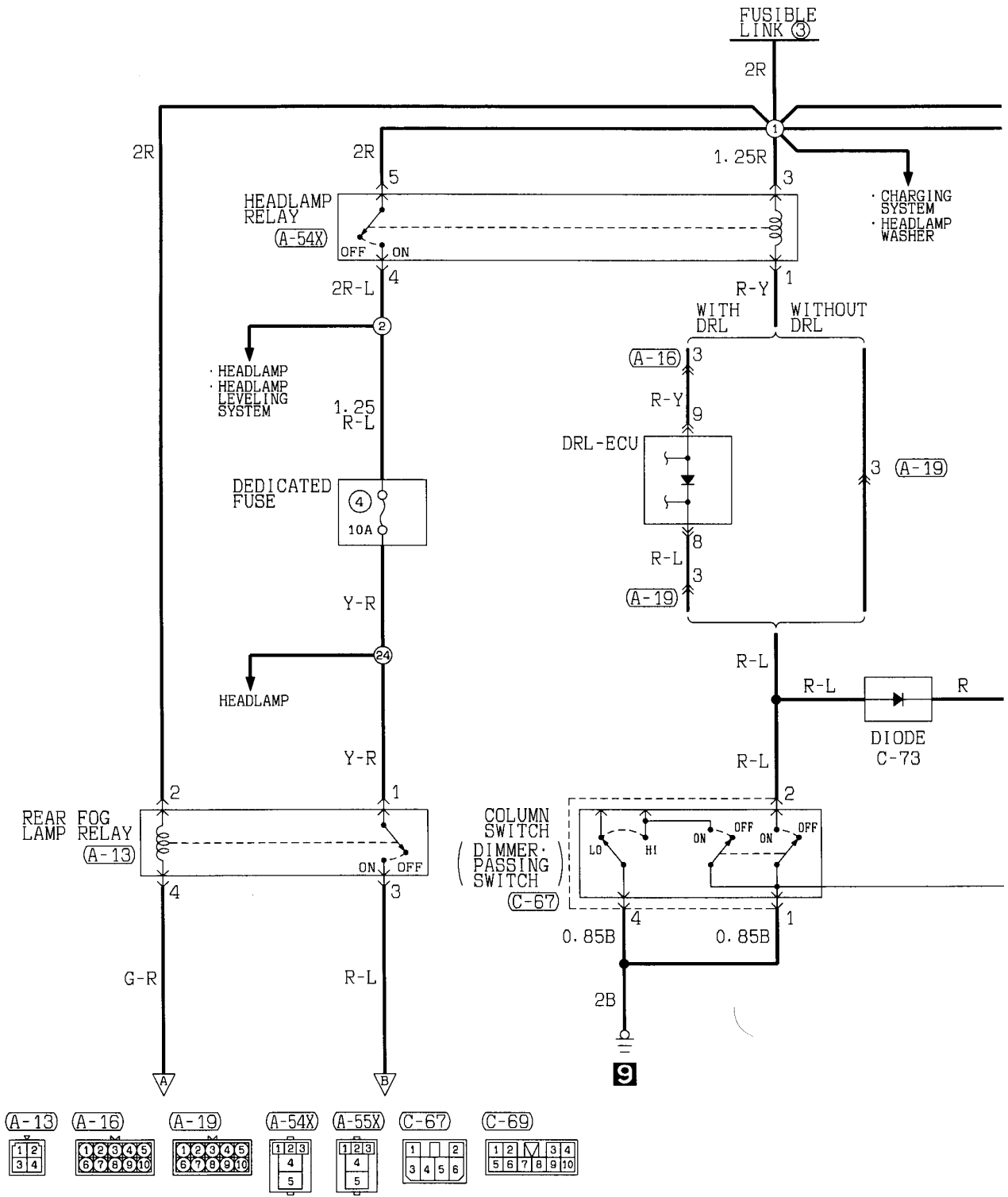

AIR CONDITIONER

90101280208

Petrol-powered vehicles

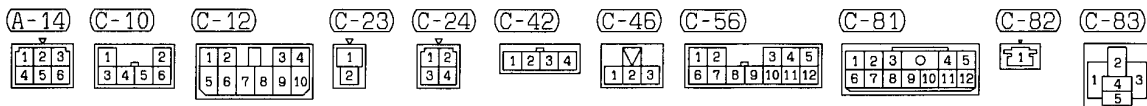
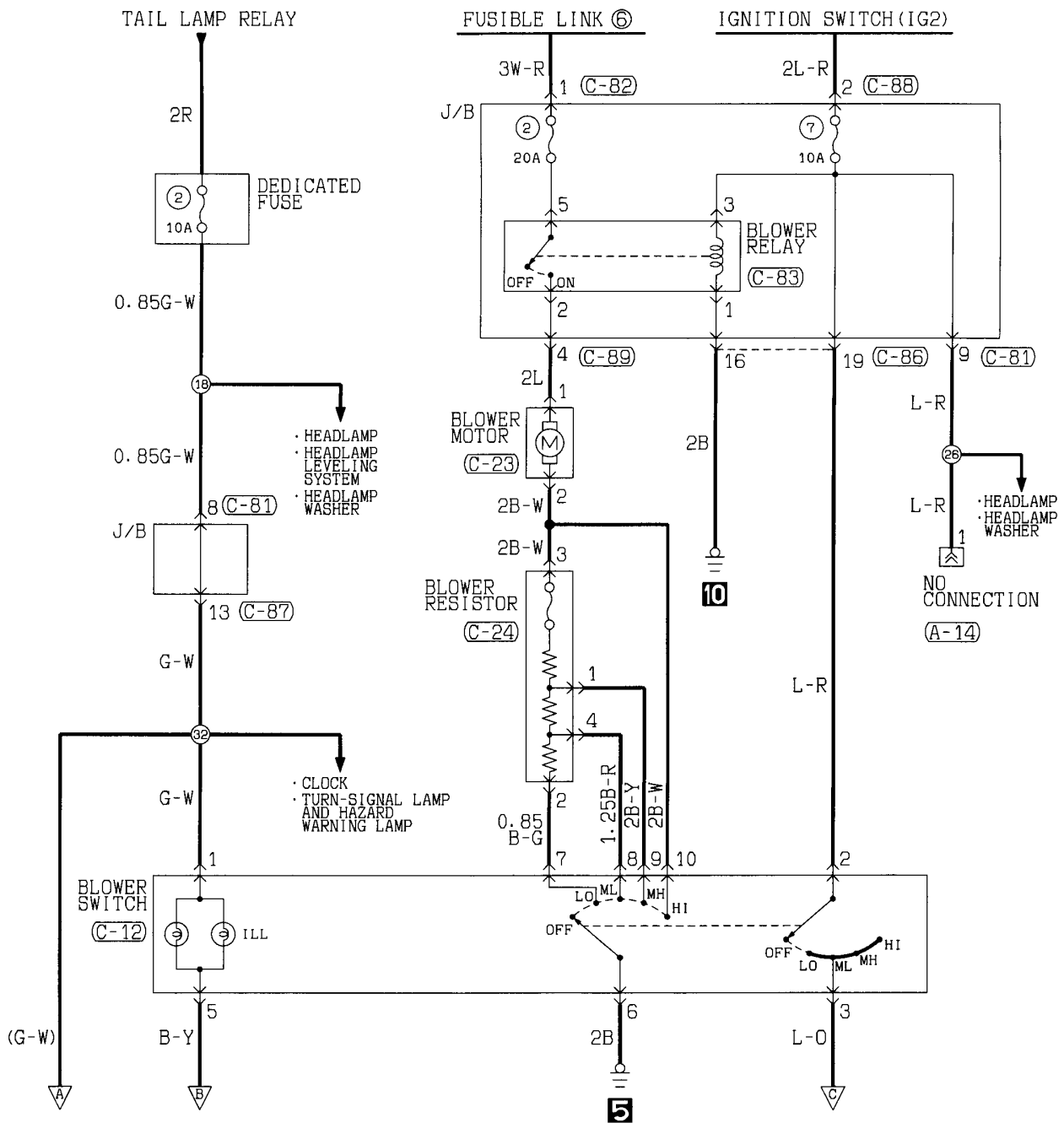

PART TIME 4WD SYSTEM

90100910016

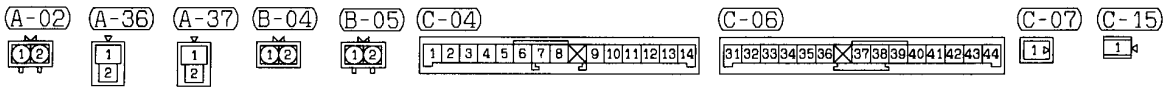
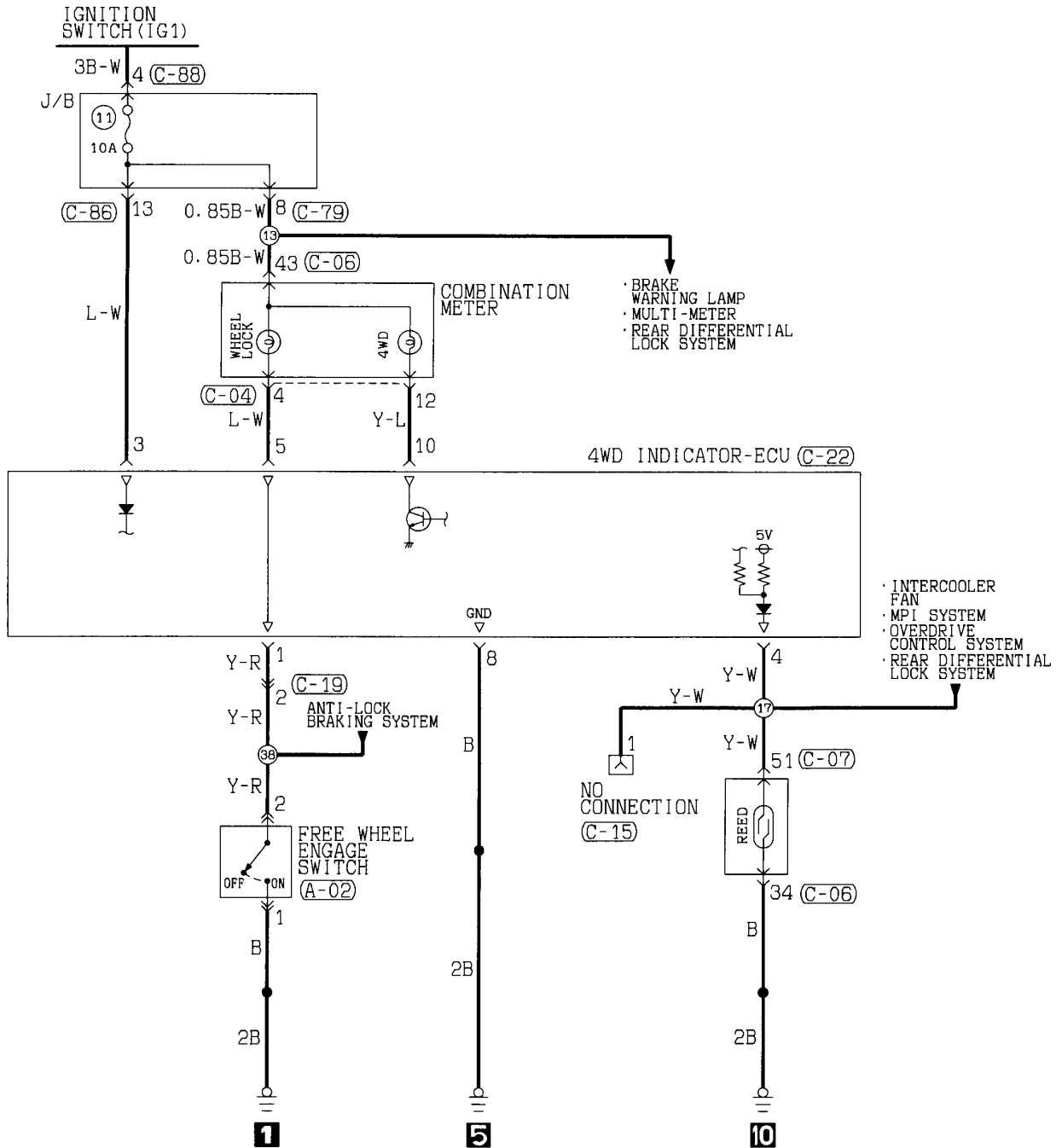

OVERALL WIRING DIAGRAM

80100010144

Single cab

<L.H. drive vehicles>

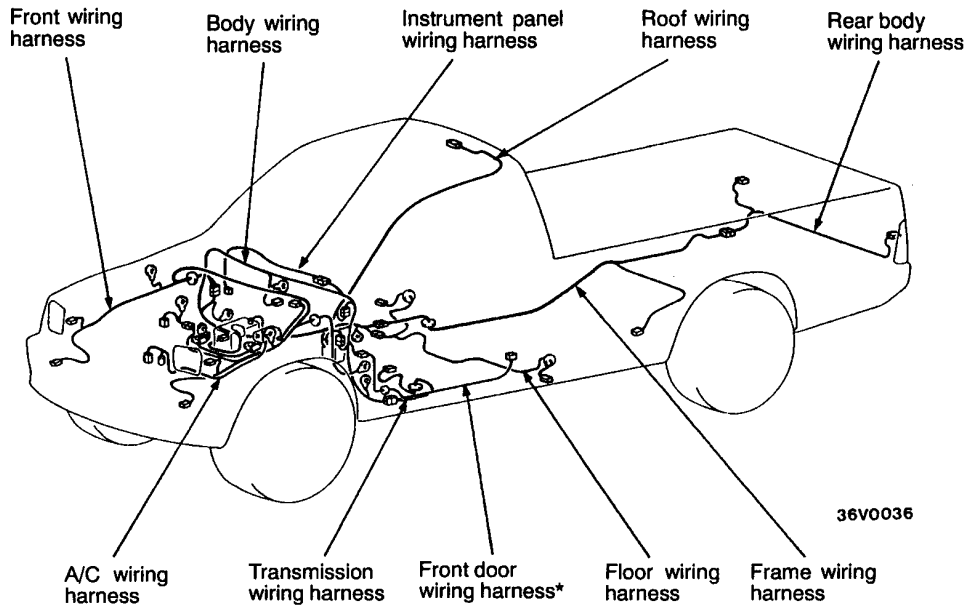

<R.H. drive vehicles>

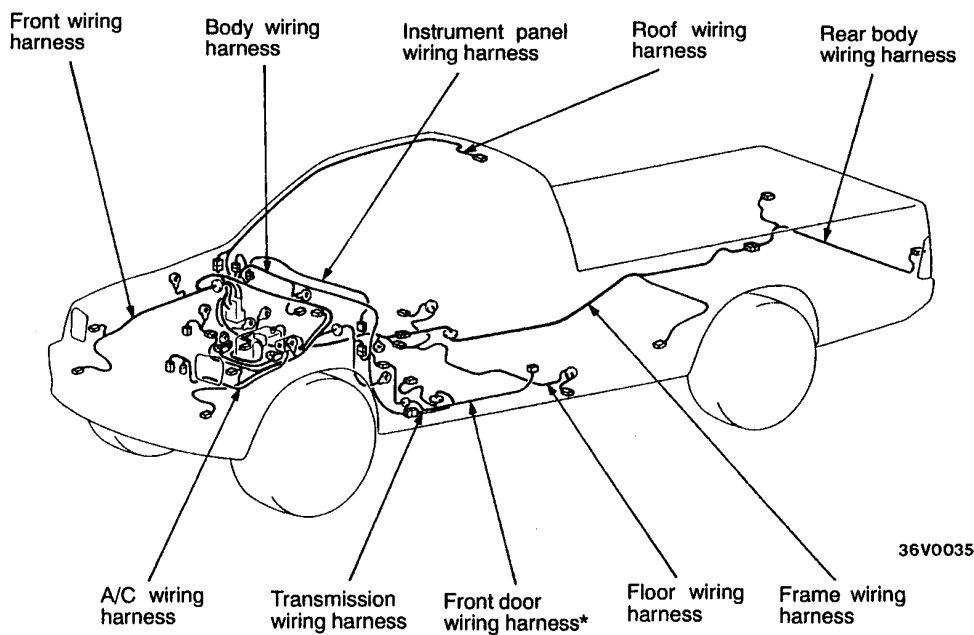

NOTE

- (1) These illustrations show only major wiring harnesses.
- (2) *: also equipped at the right side.

R.H. drive vehicles

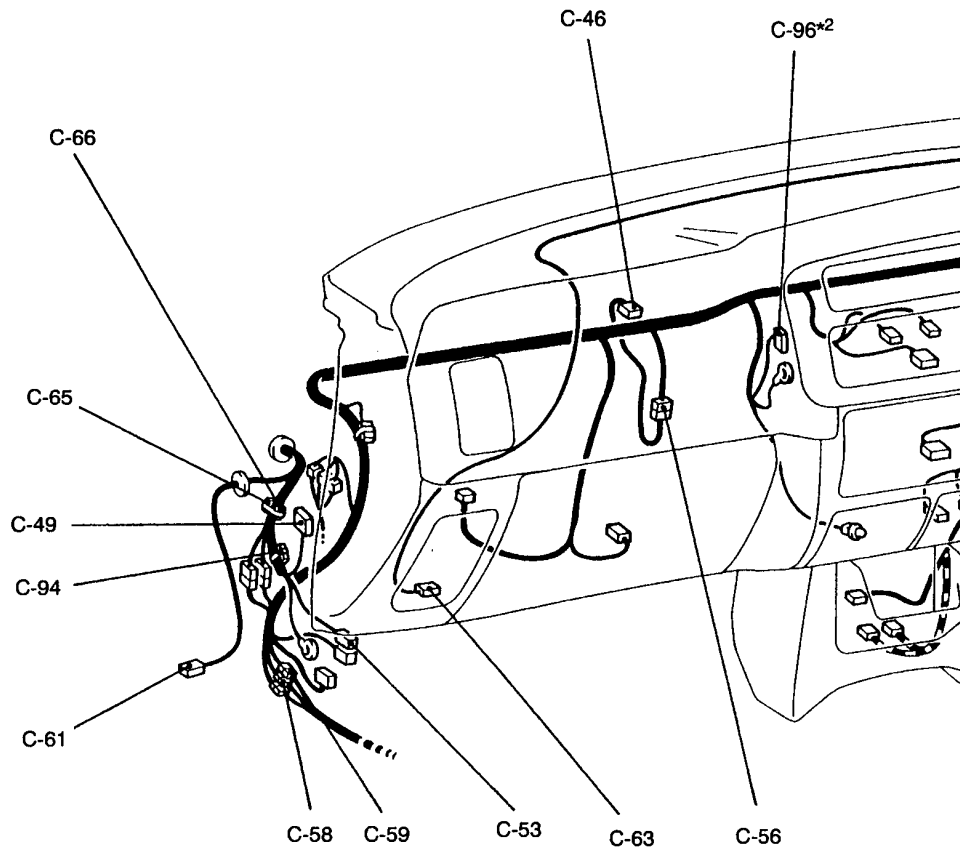
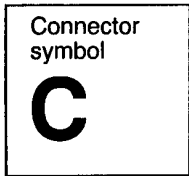

- | | | | |
|------------|---|-------------|---|
| C-41 (6-B) | Rear fog lamp switch | C-49 (13) | Grow-ECU |
| C-42 (4) | Joint connector | C-52 (2-BR) | Side turn signal lamp (RH) |
| C-43 (5) | Body wiring harness and instrument panel wiring harness combination | C-53 (4-BR) | Intercooler fan-ECU |
| C-46 (3) | Thermostat | C-55 (2-B) | Front speaker (RH) |
| C-48 (2-B) | Diode (for ABS circuit) | C-56 (12) | Thermostat wiring harness and body wiring harness combination |

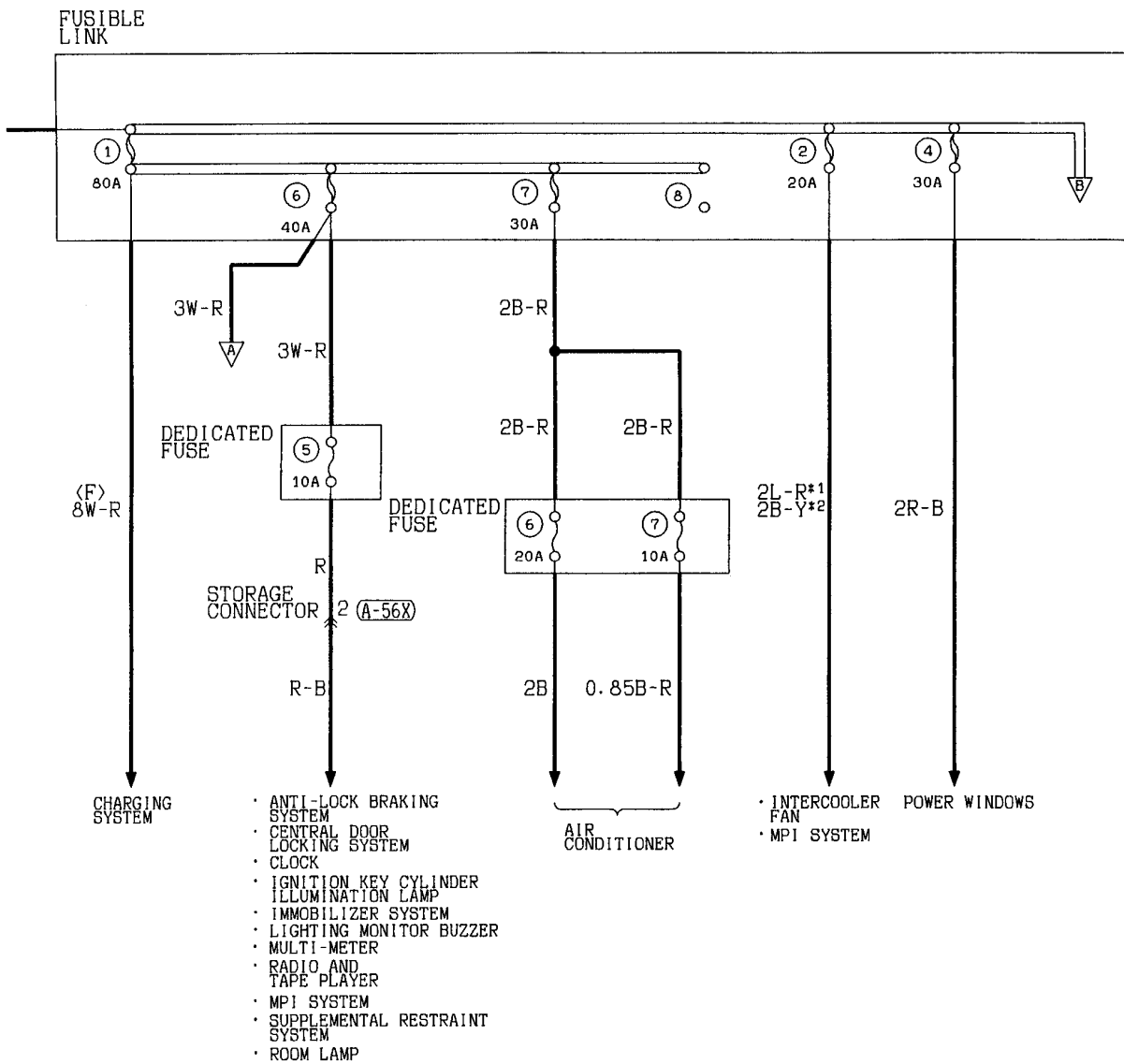

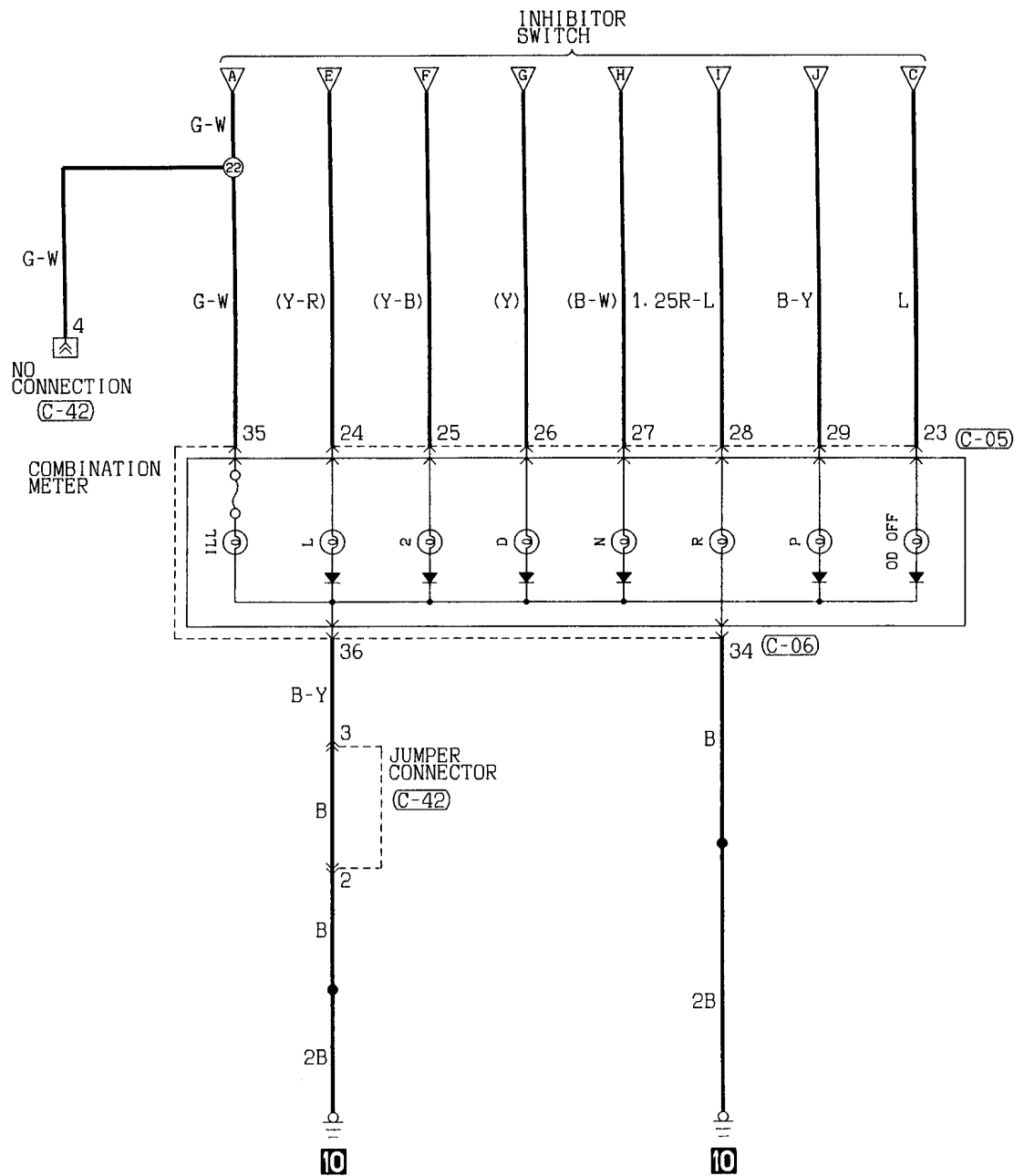

(C-42)

(C-57)

(C-86)

(C-88)

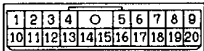
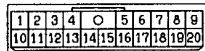

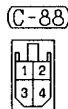
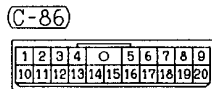
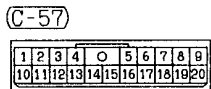
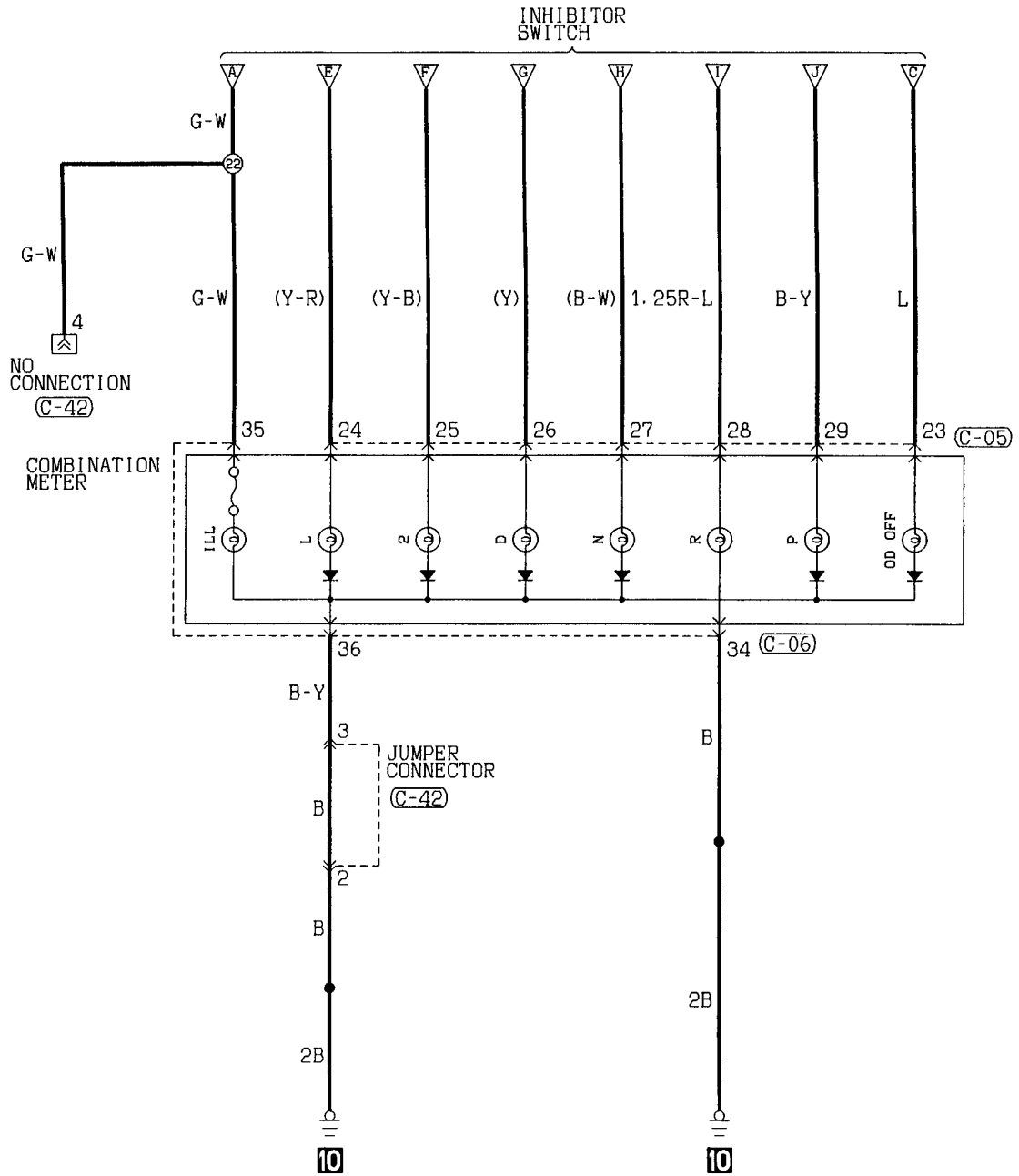

AIR CONDITIONER <Diesel-powered vehicles with A/T> (CONTINUED)

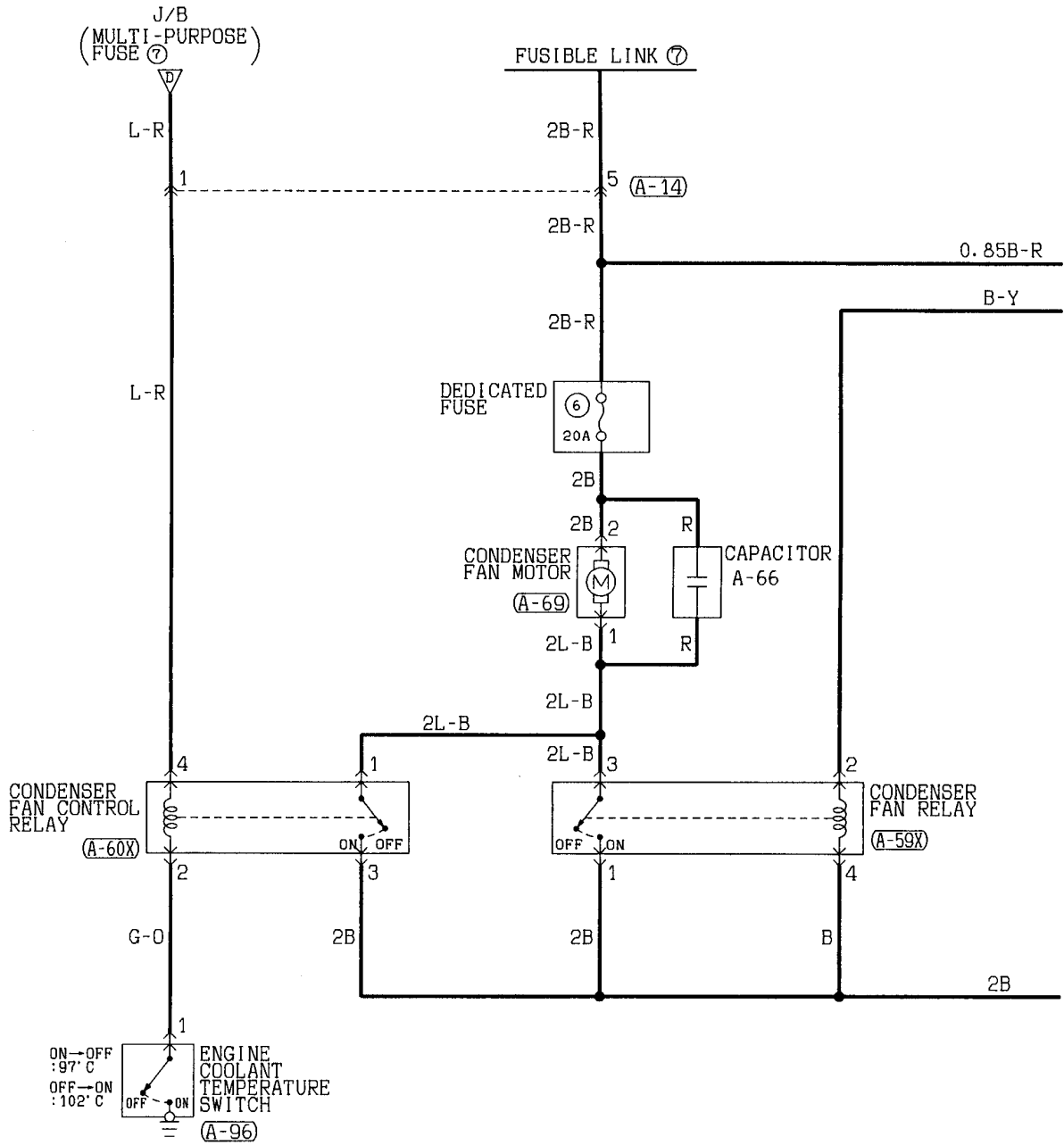

- (A-14)

1	2	3
4	5	6
- (A-58X)

1	2
3	4
- (A-59X)

1	2
3	4
- (A-60X)

1	2
3	4
- (A-67)

1	2
---	---
- (A-68)

▶

- (A-69)

1	2
---	---
- (A-84)

1	2
---	---
- (A-95)

1	2
---	---
- (A-96)

1

- (C-01)

1	2	3	4	5	6	7	8	9	10		
11	12	13	14	15	16	17	18	19	20	21	22